



Headquarters Update

Eric P. Smith
JWST & HST Program Scientist

Topics



HST items

JWST Status update

Astrophysics Division update

Discussion



- Should Hubble change its proprietary period policy?
- Is there a better way to operate Hubble in the coming years to maintain or increase its science return per dollar?
- What Hubble instrument(s) or capabilities constitute a minimum operational set?
- How do we, the scientific community, help the public “let go” of Hubble some day?

Hubble



Projected HST lifetime

HST Entry into Senior Review 2012

HST Deorbit Study

HST Lifetime

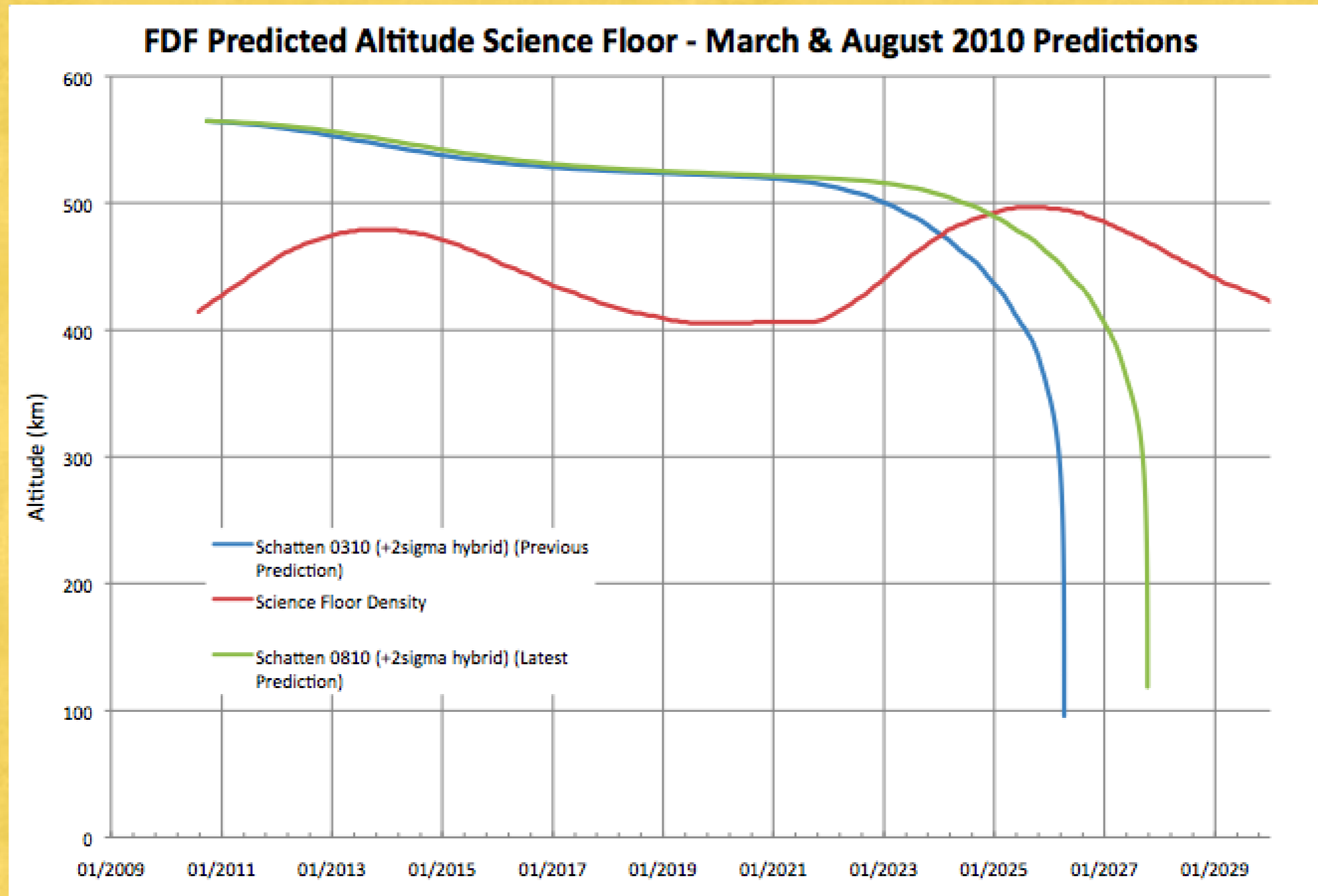

Senior Review



- Peer Review of Operating Missions
- “Performance factors are to include scientific productivity, technical status, data dissemination, future plans and expectations, and budget.”
- Opportunity to get community input for new methods of operation



James Webb Space Telescope

JWST Hardware Status



Primary Mirror Segment



Aft Optics System

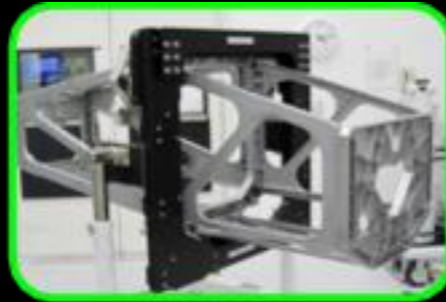

PM Flight Backplane



Tertiary Mirror

SMSS Pathfinder Strut



Fine Steering Mirror

ISIM Flight Bench



SM Hexapod

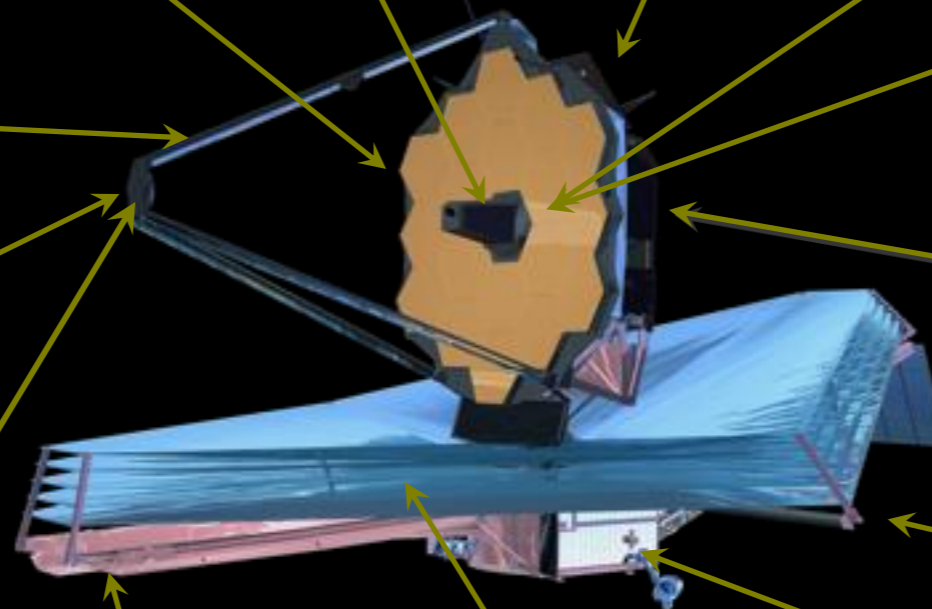

Secondary Mirror Segment



Membrane Mgmt



Pathfinder Membrane



IC&DH unit ETU



Mid-boom Test

Cryogenic Test #5: EDU gold

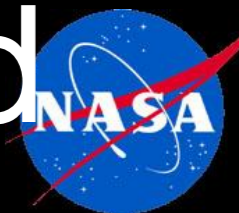

Flight Mirror Polishing Results



Primary Mirror Pre-coating Metrology

-summary of performance
- EDU post-coating cycle 1

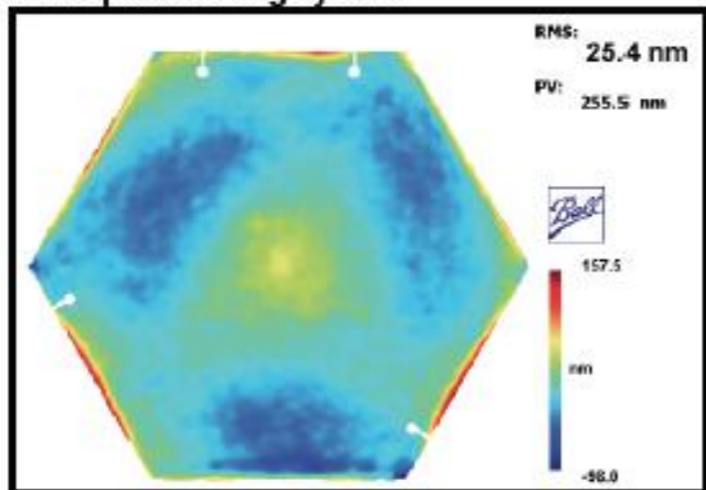

Final disposition of EDU performance will be made following 2nd cycle measurements

Flight Mirror Figures: Pre-coating

EDU

Mid: RMS = 12.1 nm
PV = 56 nm

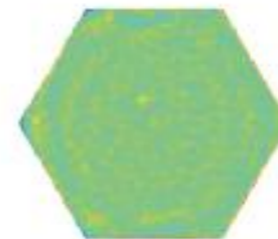
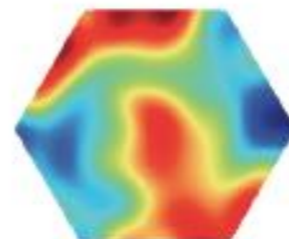

Hi: RMS = 5.4 nm
PV = 121 nm

A4: 9.8 nm

Mid: RMS = 8.2 nm
PV = 49 nm

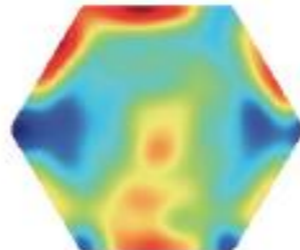

Hi: RMS = 3.2 nm
PV = 153 nm

A1: 16.4 nm

Mid: RMS = 14.62 nm
PV = 103.5 nm

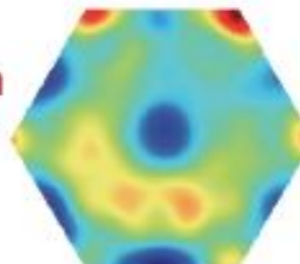

Hi: RMS = 4.3 nm
PV = 109 nm

B6: 15.6 nm

Mid: RMS = 14.9 nm
PV = 103.8 nm

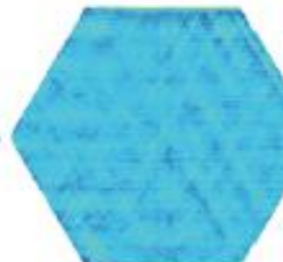
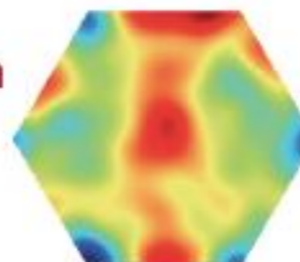

Hi: RMS = 4.3 nm
PV = 141 nm

A2: 17 nm

Mid: RMS = 15.8 nm
PV = 158.1 nm

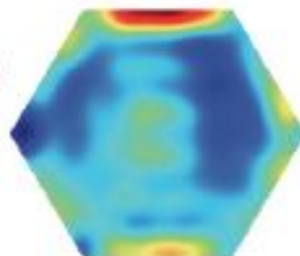

Hi: RMS = 5.6 nm
PV = 189 nm

Mirror Scorecard



Tracks completion of mirrors for delivery to SSDIF and Pathfinder

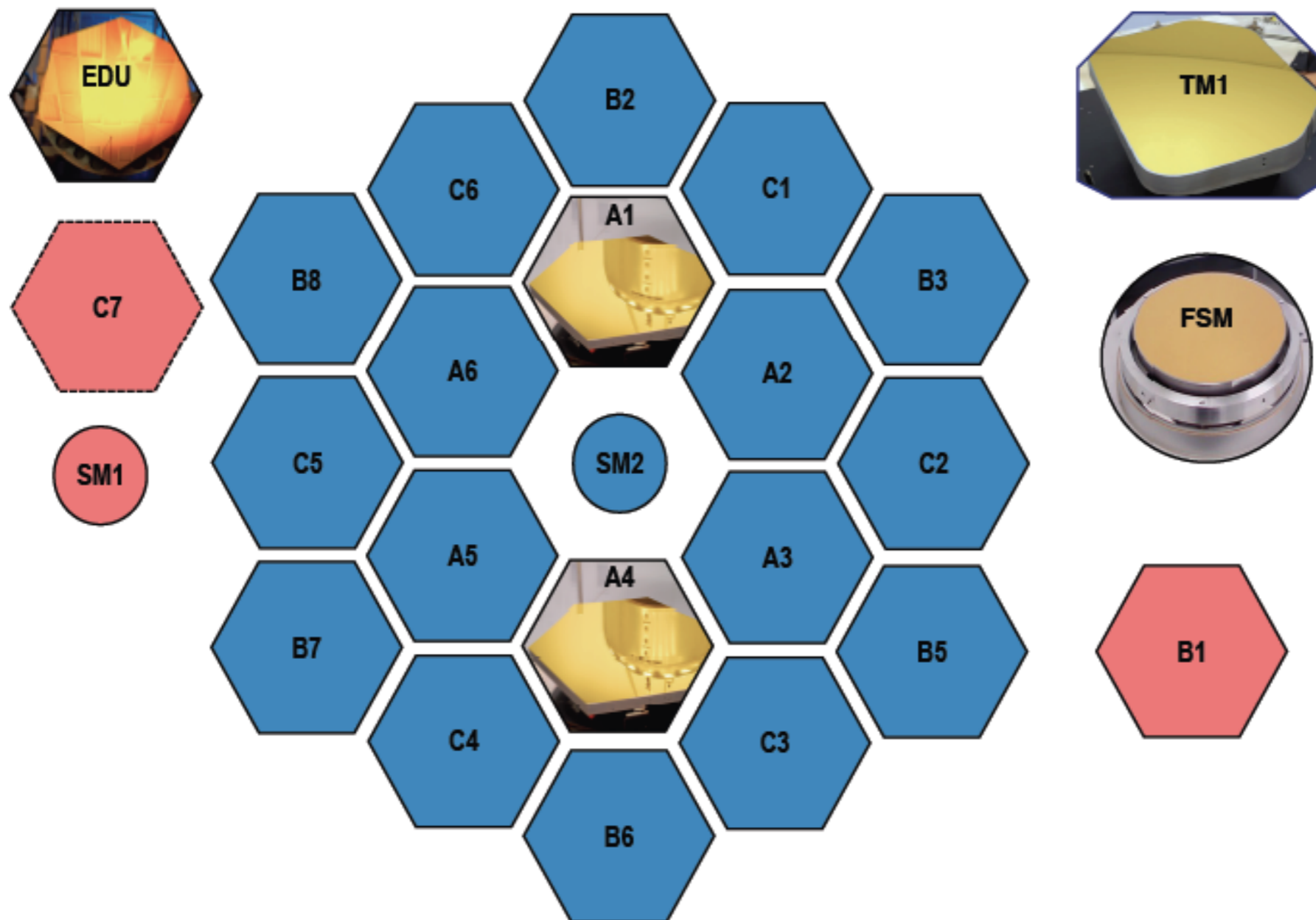

Engineering Test Units Instruments



MIRI NIRSpec NIRCam
FGS

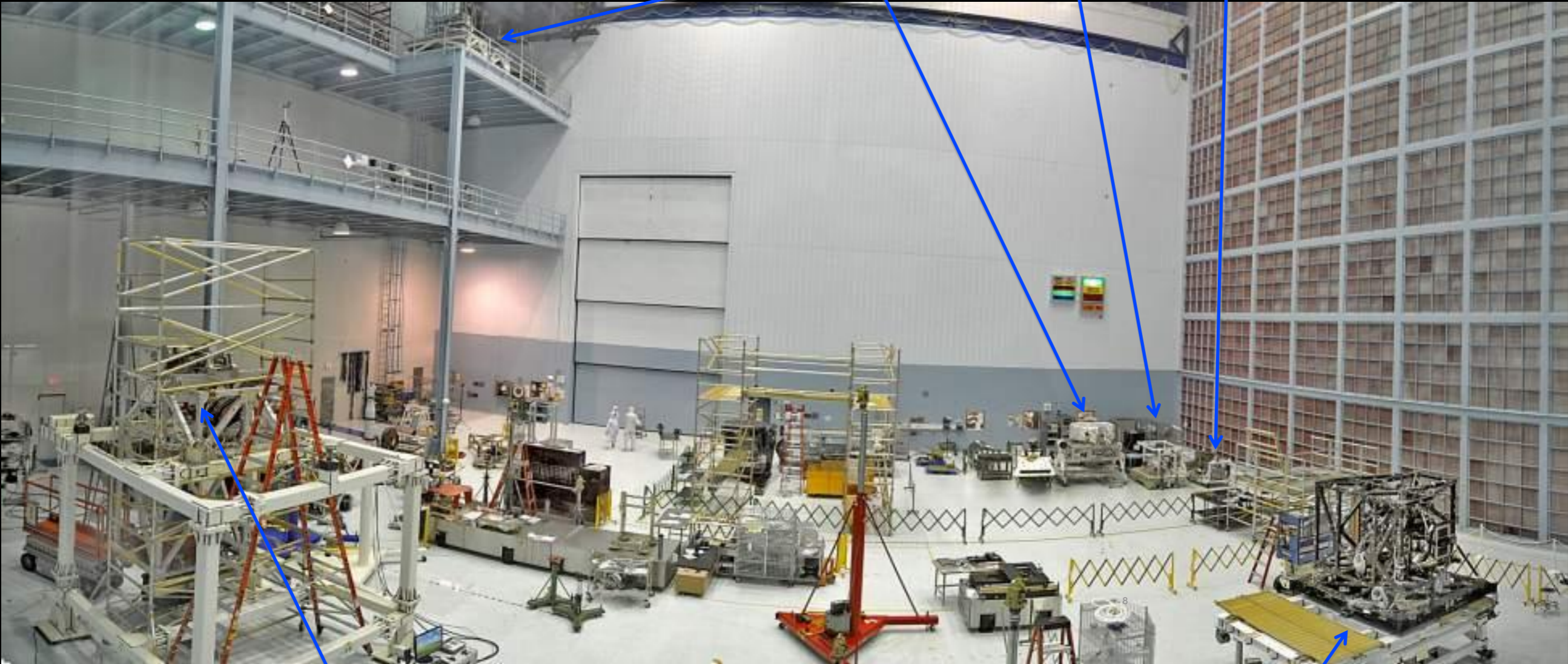

OSIM

ISIM
Structure

<http://www.jwst.nasa.gov/webcam.html>

Webb Flight Science Instruments



NIRSpec Flight Model



NIRCam Flight model under assembly



FGS Flight model

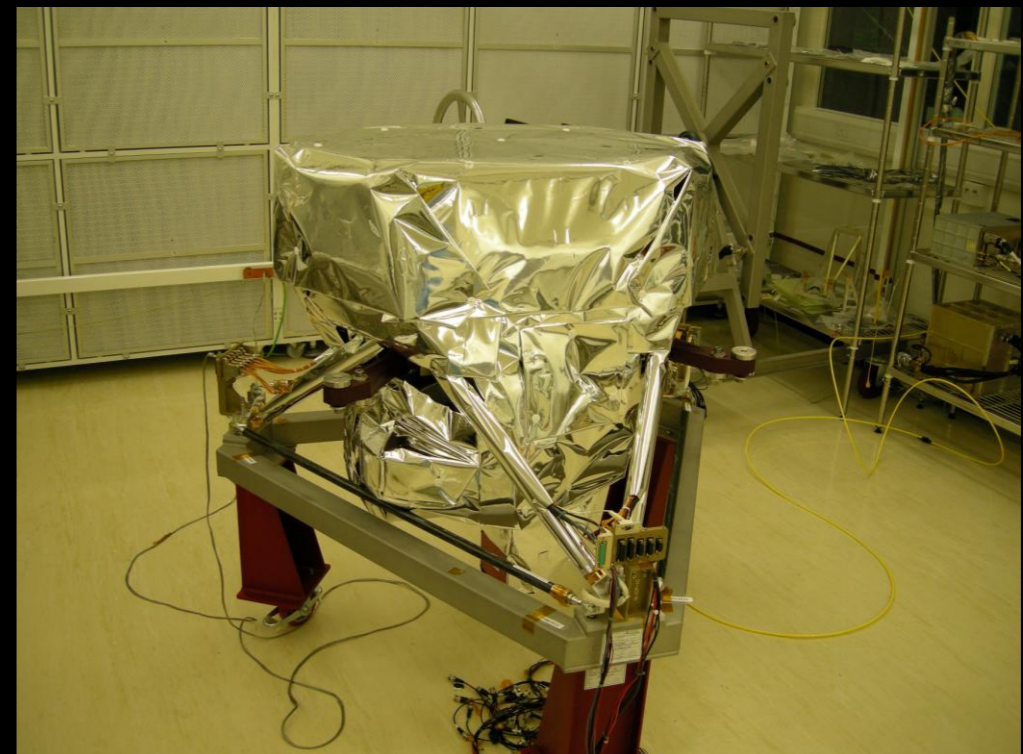

MIRI Flight model

ISIM Structure Cryoset Test

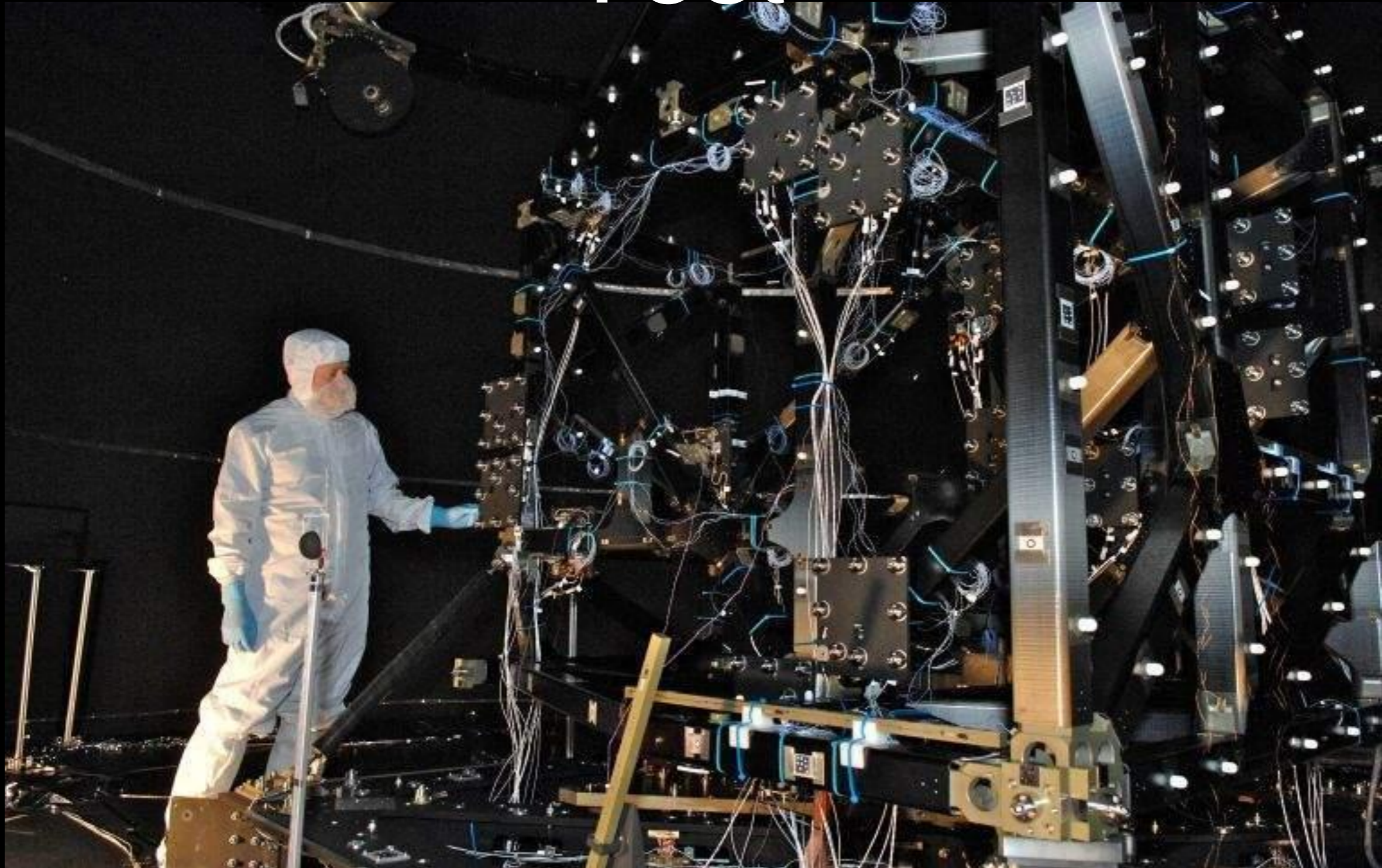

Near Term Events



MIRI flight Focal Plane System (FPS) delivery to RAL has been split into two parts

Detectors will be delivered in November 2010

Electronics (FPE) will be delivered in late December 2010 or January 2011

Major 2011 deliveries:

Deliver Flight NIRSpec to GSFC in May

ISIM Flight Structure delivery to I&T in May

ISIM Electronics Compartment Flight Model in May

Deliver Flight FGS to GSFC in May

Deliver Flight NIRCам to GSFC in July

Deliver Flight MIRI to GSFC in June



What is the Programmatic Status?

TAT, ICRP, SRB, APMC, ...

Testing Assessment Task



Budgetary, technical and schedule concerns related to cryo-optical test plans reviewed at the mission CDR led to the formation of an independent, external task to review integration and testing plans for JWST

Reviews sought on ISIM and OTE integration and test plans and science requirements driving those plans



ISIM Test Configuration



GHe shroud instillation and test completed July 09

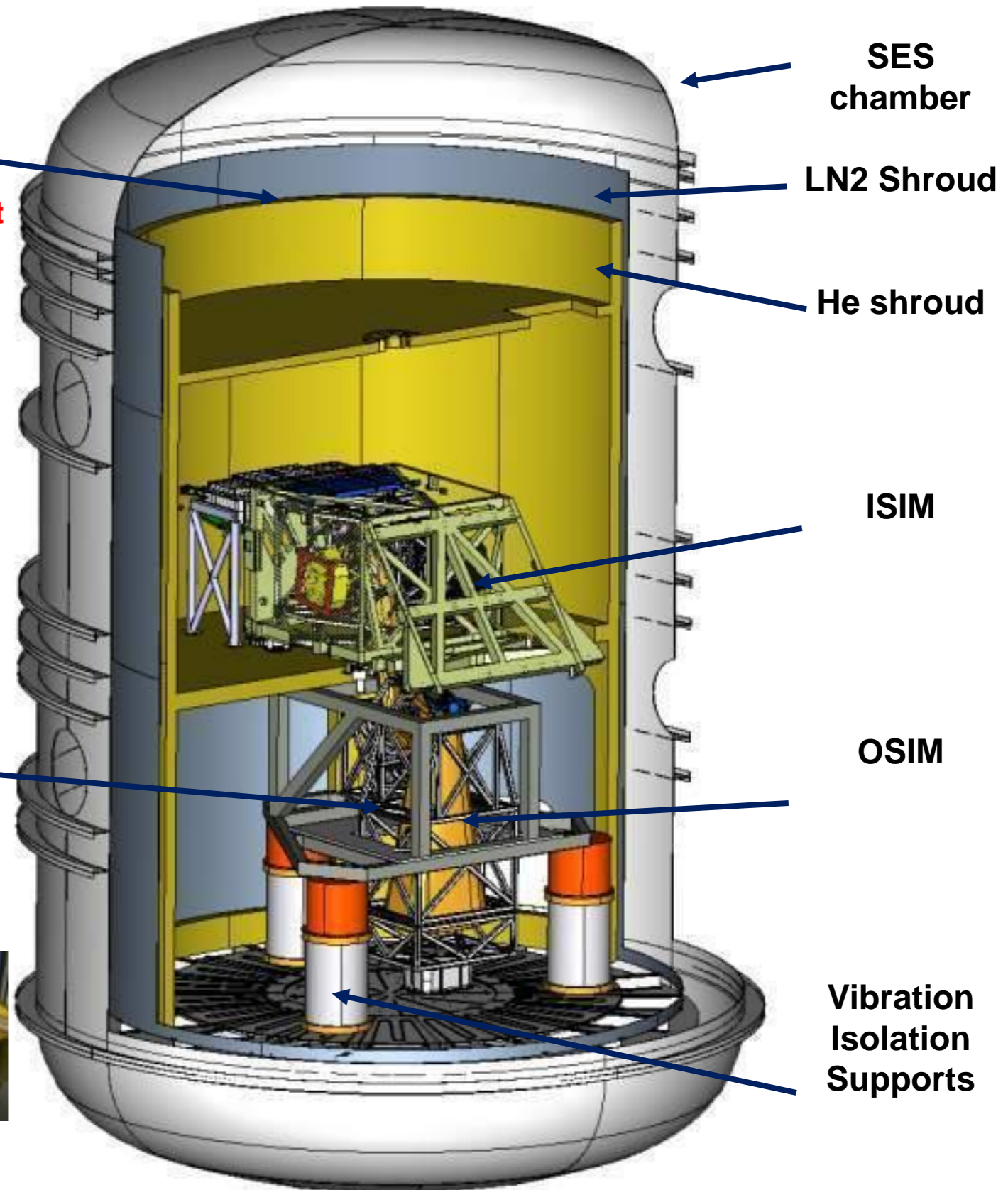

OSIM Primary Mirror

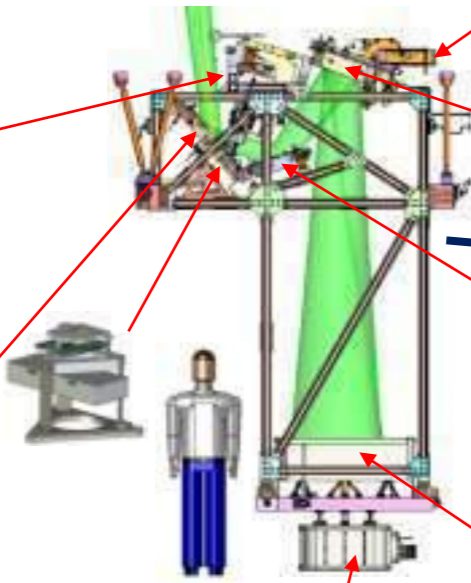

Alignment Diagnostic Module



Fold Mirror 3 Tip/Tilt Gimbal Assembly

The (OTE + ISIM = OTIS) Test

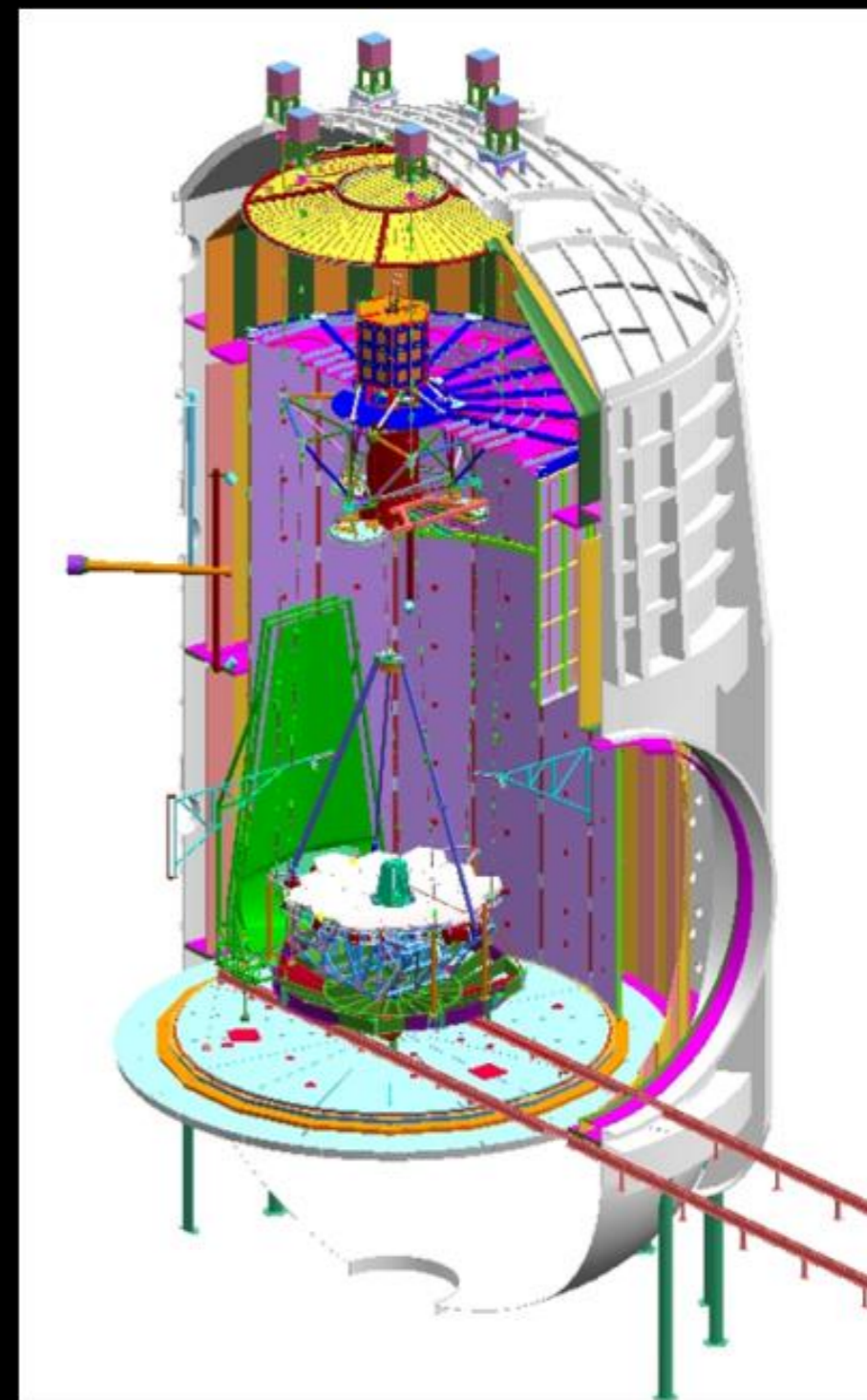
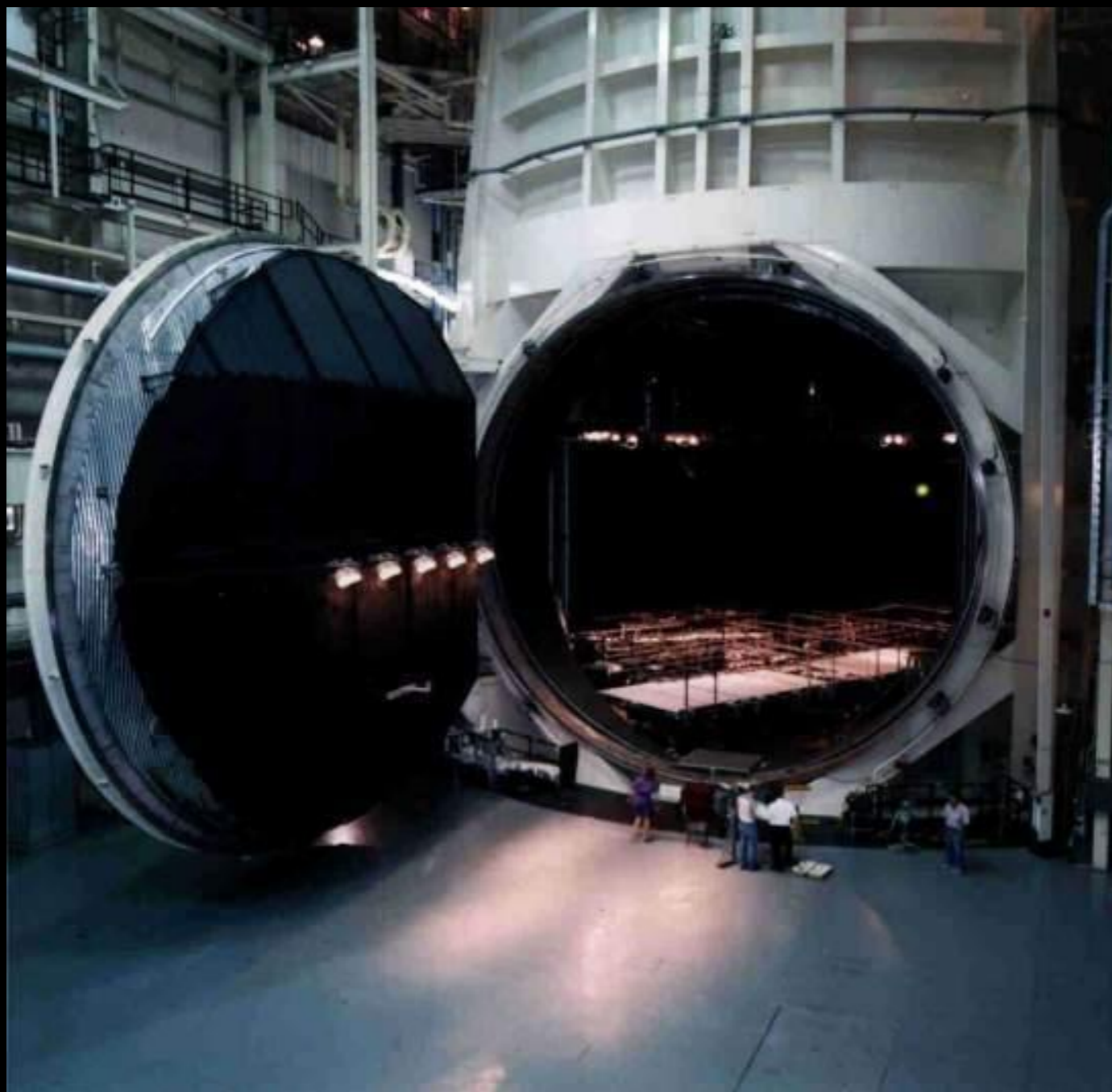

TAT Recommendations (Highlights)



- A significant level of thermal, optical, and electrical/mechanical testing is required at JSC to reach a reasonable level of mission risk
- Time required for OTIS could potentially be reduced
- ISIM test times at GSFC could be reduced
- Management of I&T program and its risks will require a clear definition of critical items including test priorities, predicted results, decision criteria, and contingency plans (HST Servicing Mission Orbital Verification model suggested as a way to ensure this)
- Relaxation of the science requirements would not necessarily lead to a straightforward simplification of test plans. Conversely, simplification of test plans or relaxing of some testing requirements does not necessarily mean that science requirements will not be

<http://www.jwst.nasa.gov/publications.html>

Independent Comprehensive Review Panel (ICRP)



June 29, 2010 letter from Senator Mikulski to NASA Administrator Bolden requesting independent and comprehensive review of JWST program

Activity completed, report due this week

Output relevant to FY11 appropriations

ICRP To Examine



1. The technical, management and budgetary root causes of cost growth and schedule delay
2. Current plans to complete development, with particular attention to the integration and test program and management structure
3. Changes that could reduce cost and schedule or diminish the risk of future cost increases without compromising Observatory performance
4. The minimum cost to launch JWST, along with the associated launch date and budget profile, including adequate reserves



Astrophysics Division

Astrophysics Mission Timelines

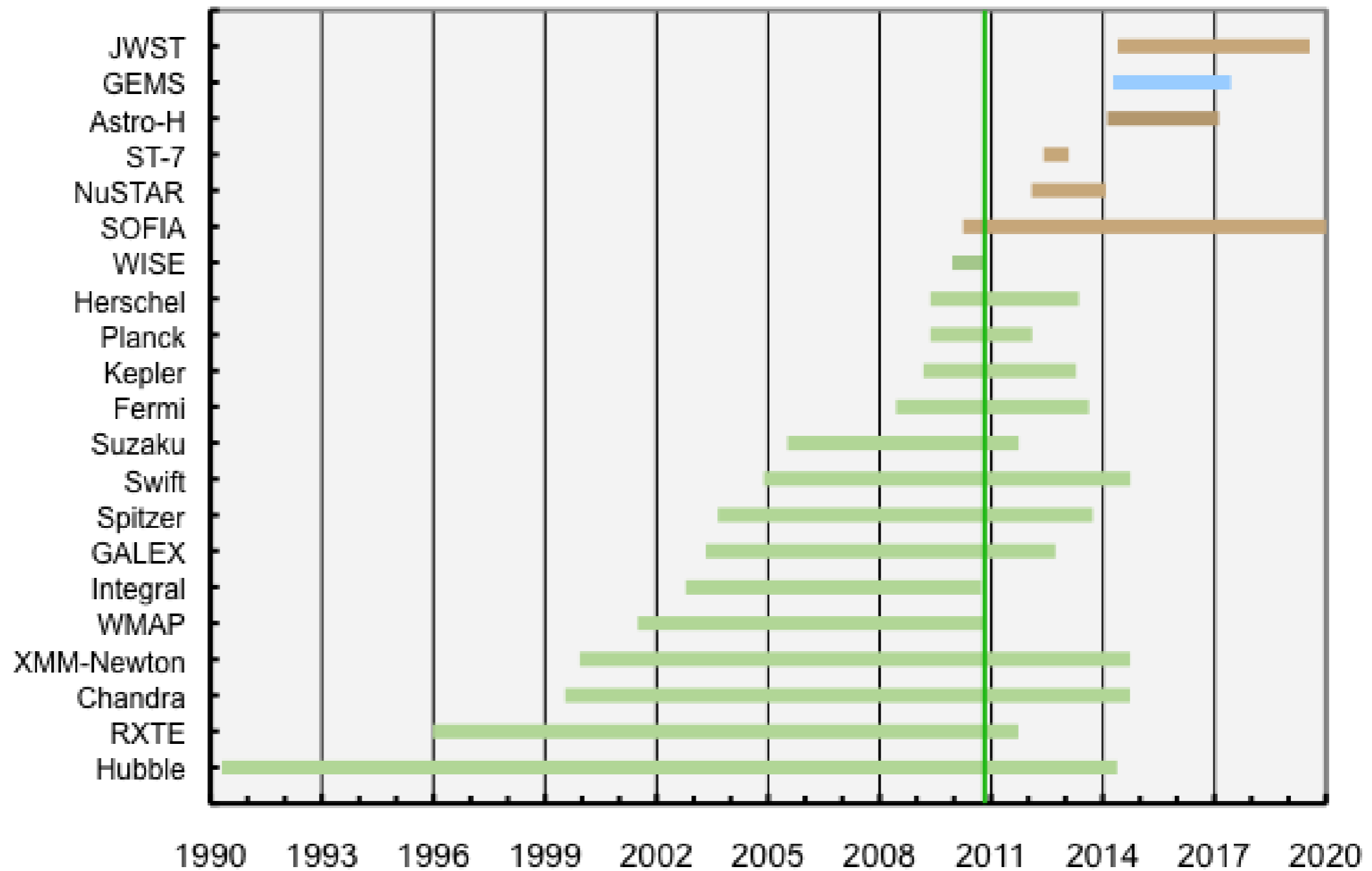

Green: operational, Brown: development, Blue: Formulation

Astrophysics Near Term Schedule



	CY2010	2011	2012	2013	2014																	
Mission Launches etc.		▽ Dec SOFIA Early Sci		▽ Feb NuSTAR	▽ Jun LPF/ST-7																	
Suborbital Rocket Program.	▽ May D I C E 2	▽ Jul C I B E R 2	▽ Nov X Q C 4	▽ Nov P I C T U R E 1	▽ Jan E X O S 2	▽ Jan M I C R O X	▽ Feb F I R E	▽ Mar I M A G E R 1	▽ Apr F O R I S 1	▽ Apr S L I C E	▽ Aug A C C E S S 1	▽ Sep E X O S 3	▽ Sep F U S P 1	▽ Oct F O R T I S 2	▽ Jan X A C T 1	▽ Mar E X O S 4	▽ Mar A C C E S S 2	▽ Apr X Q C 5	▽ Sep X A C T 2	▽ Sep A C C E S S 3	▽ Nov F U S P 2	▽ Mar A C C E S S 4
Balloon Campaigns																						
Antarctica	N/D/J	(CREAM V, SPB Test)	D/J																			
Sweden																						
Ft. Sumner (spr)			M/J (TBR)																			
Palestine			A/M																			
Ft. Sumner (fall)			J/J																			
Australia	M/A (TIGRE, NCT*)	S/O (FACTEL, COFE, HASP)	A/S																			
		M/A (HERO)		M/A																		
Opportunities	Apr ▽ Sr Rev	TBD ▽ Explorer AO	Future AOs will depend upon the results of the Astro2010 Decadal Survey																			

Legend
 * - NCT Balloon flight aborted.
 Grey - Backup 2010 suborbital launch

Astrophysics Program



	FY09	FY10 *	FY11	FY12	FY13	FY14	FY15
FY11 President's Budget	1,304.9	1,103.9	1,076.3	1,109.3	1,149.1	1,158.7	1,131.6
Astrophysics Research	136.0	147.7	156.1	178.1	188.4	194.6	199.6
Research and Analysis	60.0	60.0	60.2	64.7	65.8	67.4	69.1
Balloons	25.6	26.7	27.1	32.4	32.7	35.3	36.8
ADCAR / ADP / Senior Review / Admin	50.4	61.1	68.7	80.9	89.8	91.9	93.7
Cosmic Origins	850.0	686.3	687.7	669.4	667.5	640.5	599.2
James Webb Space Telescope	466.9	440.3	444.8	379.2	335.2	259.3	119.2
HST	203.1	112.6	102.7	104.5	99.8	98.0	98.6
SOFIA	77.4	72.8	79.6	80.1	79.2	81.1	81.3
Spitzer	61.7	27.1	22.6	14.0	0.3		
SR&T	3.2	5.2	7.0	10.1	11.5	12.5	15.0
Herschel	17.2	23.0	24.5	24.0	20.8	15.8	5.8
Future Missions/Servicing/Management	20.5	5.3	6.5	57.6	120.8	174.0	279.3
Physics of the Cosmos	111.1	115.8	103.3	114.4	151.7	176.4	202.0
Fermi (GLAST)	13.2	22.2	22.7	25.9	25.5	25.1	25.1
Planck	6.4	8.9	8.1	6.5	6.5	3.0	0.8
Chandra / INTEGRAL / XMM	69.7	64.8	59.4	59.0	59.3	59.7	59.8
SR&T	2.8	4.3	5.6	9.8	11.7	13.0	15.0
JDEM	8.5	4.4					
LISA, IXO, Future and Management	10.5	11.1	7.5	13.2	48.7	75.6	101.3
Exoplanet Exploration	72.1	46.2	42.5	54.1	83.0	93.8	117.6
Kepler	31.7	20.1	16.9	19.1	13.8	0.2	
SIM	20.0	2.0					
Keck/LBTI	3.7	5.3	4.1	3.2	3.3	3.4	3.5
SR&T	11.0	13.3	12.7	16.3	17.8	18.2	18.8
Future Missions/Management	5.7	5.6	8.8	15.5	48.0	72.0	95.4
Astrophysics Explorer	135.7	107.9	86.7	93.3	58.5	53.3	13.2
WISE	69.2	13.0	6.8	2.7	0.2		
NuSTAR	38.7	59.9	32.1	10.8	6.2		
Astro-H	6.4	10.9	12.5	7.0	7.4	12.6	11.1
GEMS	1.7		21.0	57.7	44.7	40.8	2.1
Operating Explorers	19.6	24.0	14.4	15.1			

* FY10 Enacted Budget

Decadal Priorities



Program Scale	Recommendation	Science	Total Cost (U.S. share)	Launch Date
Large	WFIRST (potential interagency & international partnerships)	Dark energy, exoplanets, and infrared survey-science	\$1.6B	2020
Large	Explorer Program Augmentation	Enable rapid response to science opportunities; augments current plan by 2 MIDEXs, 2 SMEXs, & 4 MoOs	\$463M	Ongoing
Large	LISA (requires ESA partnership)	Open low-frequency gravitational-wave window for detection of black-hole mergers and compact binaries and precision tests of general relativity	\$2.4B (\$1.5B)	2025
Large	IXO (partnership with ESA and JAXA)	Black-hole accretion and neutron-star physics, matter/energy life cycles, and stellar astrophysics	\$5.0B (\$3.1B)	2020s
Medium	New Worlds Technology Development Program	Preparation for a planet-imaging mission beyond 2020, including precursor science activities	\$100-200M	>2020
Medium	Inflation Probe Technology Development Program	CMB/inflation technology development and preparation for a possible mission beyond 2020	\$60-200M	>2020
Small	Astrophysics Theory Program Augmentation	Broad	\$35M additional	
Small	(Definition of) a future UV-optical space capability	Technology development benefiting a future UV telescope to study hot gas between galaxies, the interstellar medium, and exoplanets	\$40M	
Small	Intermediate Technology Development Augmentation	Broad; targeted at advancing the readiness of technologies at TRL 3 to 5	\$2M/yr additional, increasing to \$15M/yr additional by 2021	
Small	Laboratory Astrophysics Augmentation	Basic nuclear, ionic, atomic, and molecular physics to support interpretation of data from JWST and future missions	\$2M/yr additional	
Small	SPICA instrument (U.S. contributions to JAXA-led mission; possibly w/ ESA)	Understanding the birth of galaxies, stars, and planets; cycling of matter through the interstellar medium	\$150M	
Small	Suborbital Program Augmentation	Broad, but including especially cosmic microwave background and particle astrophysics	\$15M/yr additional	
Small	Theory and Computation Networks (NASA, NSF, DOE)	Broad; targeted at high-priority science through key projects	\$5M/yr NASA	29

New Opportunities



	Release	Due Date	Contact Person
ESA M3 Cosmic Visions Letter of Acknowledgement	10-6-2010	10-25-2010	Paul Hertz
WFIRST SDT	10-19-2010	11-23-2010	Rita Sambruna
Euclid Science Team Member	10-21-2010	12-20-2010	Richard Griffiths
Explorer Call	11-01-2010	02-16-2011	Barbara Giles

Discussion



- Should Hubble change its proprietary period policy?
- Is there a better way to operate Hubble in the coming years to maintain or increase its science return per dollar?
- What Hubble instrument(s) or capabilities constitute a minimum operational set?
- How do we, the scientific community, help the public “let go” of Hubble some day?