

NHST design issues

R. A. Woodruff

robert.a.woodruff@lmco.com

(303) 918-5639

Lockheed Martin

4/10/03



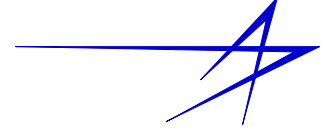

Candidate mission options for NHST

Ultraviolet Imaging

Visible Coronagraphy

Very-wide FOV visible imaging

Ultra-wide FOV visible imaging

- Each is a large telescope with precise and stable system wavefront control
 - Large mirrors, structure, system
 - All require sensing and controlling of WFE
- Basic designs are similar
- Complementary design issues
- Technology needs are similar

Typical requirements

(1 of 2)

• Ultraviolet Imaging

- Wavelength range
 - 100 to 300/1000 nm
- D (m) /FOV (°) /IFOV (mas) /f(m): FPA
 - f/8: 4 x 10 m/ 300 °/ 30 mas/ 80 m: 10K x 10K [uv.1 (off-axis), uv.2 (on-axis)]
 - f/150: 4 x 10 m/ 25 °/ 4 mas/ 620 m: 6K x 6K [uv.3]
- X-FOV 12 to 24 arc minutes for other science
- WFE: 7 nm rms: D.L. at 100 nm.
- Minimize number of mirrors
- Solar blind detectors
- Contamination control

• Visible coronagraphy, Planet Detection

- Wavelength range: 500 – 1000 nm
- D(m) /FOV(°) /IFOV(mas) /f(m): FPA
 - f/40: 4 m/ 1.9 °/ 15 mas/ 165 m: 128 x 128
 - f/50: 4 x 10 m/ 3 °/ 5 mas/ 495 m: 600 x 600 [tpf.1]
- Contrast of 10^{10} @ $4 \lambda/D$ [50 to 100 mas]
 - WFE: < 150 pm rms {CSFR, 3 to 60 cpa}, 2 nm rms LSFR
- More mirrors allowed, but be careful
- Real pupil images
 - Apodizer, Lyot Stop
- WFE corrected field image
- Very low noise, high QE detectors with low red-leak

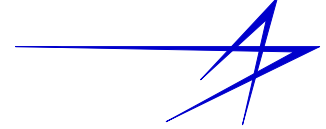

Typical requirements (2 of 2)

- **Very-wide FOV Imaging**
 - Wavelength range: 350-1000 nm
 - D (m)/FOV (°)/IFOV (mas)/f(m): FPA
 - f/120: 4 m/ 480 °/ 5 mas/ 500 m: 96 K x 96 K [9 G-pixels]
 - WFE
 - 14 nm rms
 - D.L. at 200 nm.
 - More mirrors allowed than UV
 - Low noise, high QE detectors with low red-leak
- **Ultra-wide FOV Imaging**
 - Wavelength range: 350 – 1000 nm
 - D (m)/FOV (°)/IFOV (mas): FPA
 - f/6: 4 m plus/ 600 °/ 100 mas: 6 K x 6 K [4 M-pixels]
 - f/6: 4 m plus/ 3600 °/ 100 mas: 1 sq. degree [1.3 G-pixels], uwfov.1
 - FOV/IFOV: 100 square arc minutes to few square arc degrees/ 100 mas
 - WFE: 36 nm rms: D.L. at 1000 nm.
 - More mirrors allowed than UV
 - Low noise, high QE detectors with low red-leak
 - Examples: SNAP and UWFI

Complementary requirements

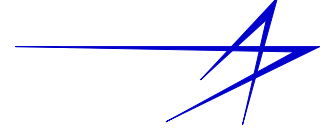

			D (m)	λ_{cs}	# of mirrors	$\tau (\lambda_{cs})$	WFE overall (nm rms)	WFE PM (nm rms)	Corrected WFE, CSFR (pm rms)	WFS	WFC
Very WFOV	TMA	RC + relay	4+	200 nm	4 to 6	0.9	14	3	NA	Focus, THO, LSFR	Passive or adaptive, PM support, SM 5 DoF
Ultra WFOV			4+	1000 nm	4 to 6	0.9	36	14	NA	Focus, THO, LSFR	Passive or adaptive, PM support, SM 5 DoF
UV imager			4 x 10	100 nm	3 to 4	0.4 to 0.5	7	2	NA	Focus, THO, LSFR	Passive or adaptive, PM support, SM 5 DoF
Coronagraph (Off-axis aperture)		TC + TM + relay	4 x 10 or 4	500 nm	7	0.85	2, corrected	2	20 - 50	Focus, THO, LSFR, CSFR	Active: DM. Adaptive: SM 5 DoF, PM, support, LOS jitter, Body point.

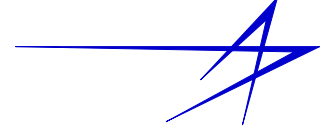

Resultant design forms:

TMA, Ritchey Chretien, True Cassegrain+Relay

- **Ultraviolet Imaging**
 - Two mirror RC or TMA
 - Passive WFC
 - Force actuators on PM (and SM?)
 - Precision figured optics
 - Precision alignment: structural and thermal
 - Enhanced Al coating
 - Low red leak filters
 - Large photon counting FPA

- **Very/Ultra-wide FOV Imaging**
 - **Ultra-wide FOV: TMA or RC + all reflective corrector**
 - **Very WFOV TMA**
 - Standard “HST-like” WFE control
 - Passive WFC
 - Protected Ag coating
 - Extremely large FPA. Large radiator to cool arrays.

*Typical TMA design:
UV Imager.*

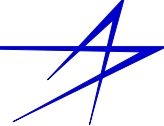

[uv.1] 300 arc sec camera.

*Total FOV available for science
package:
300 arc sec by 24 arc min*

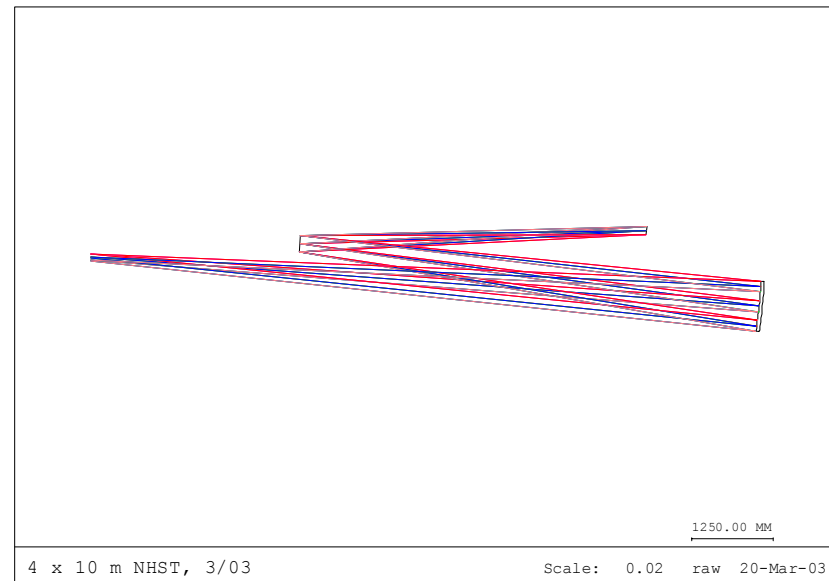
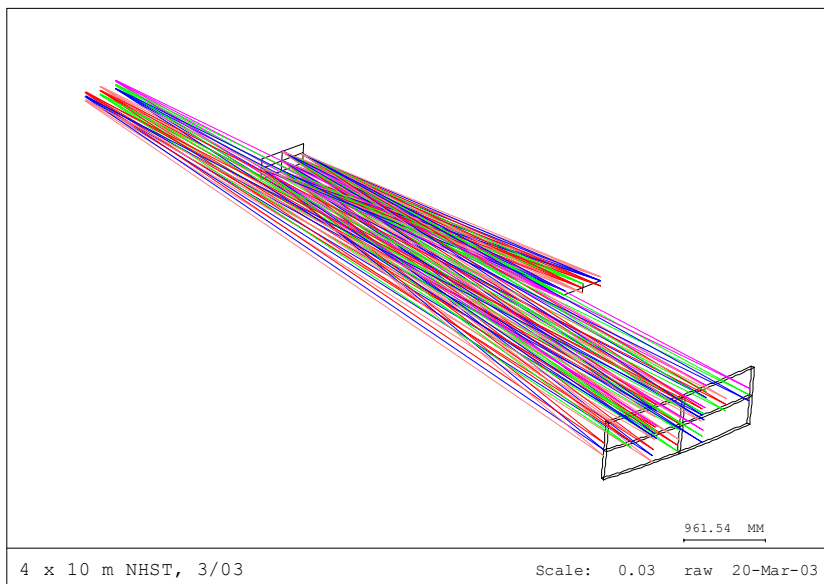
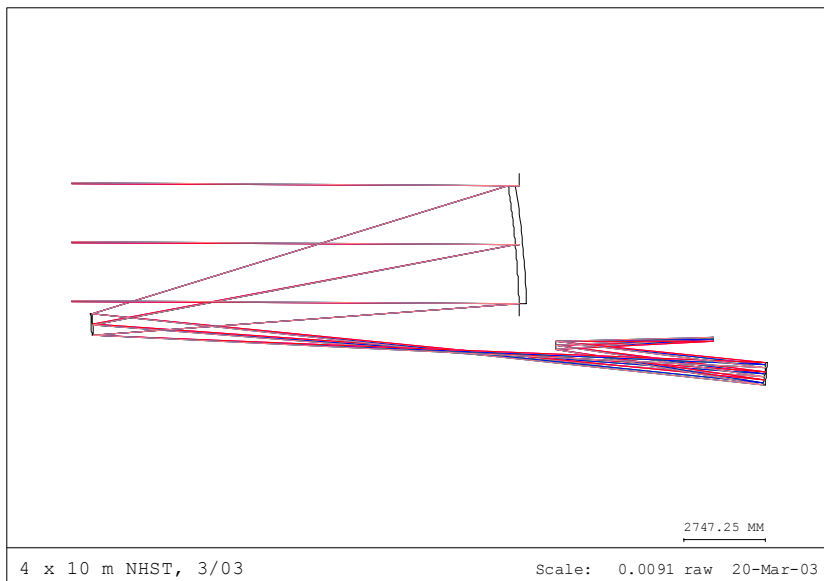



Typical TMA design:

UV Imager.

[uv.2] 300 arc sec camera.

*Total FOV available for
science package:*

300 arc sec by 24 arc min

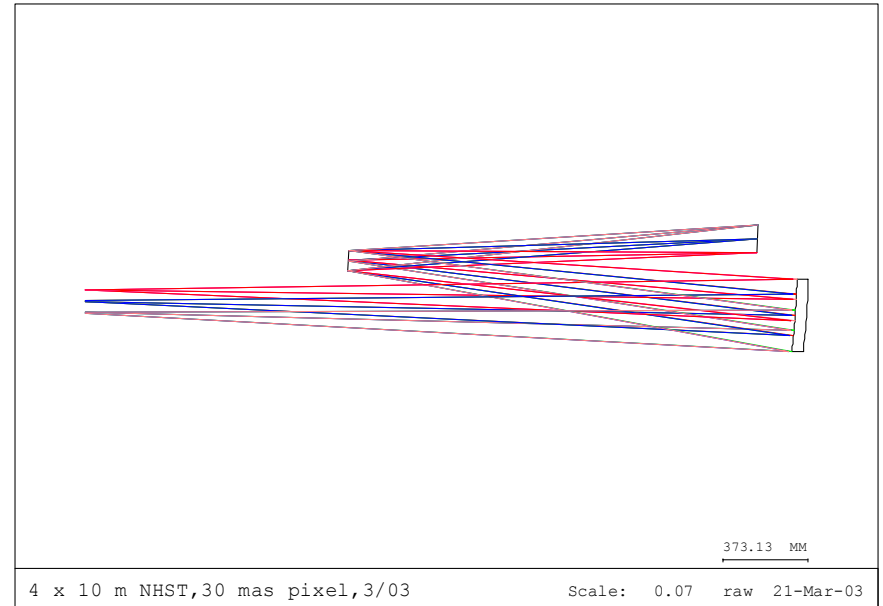
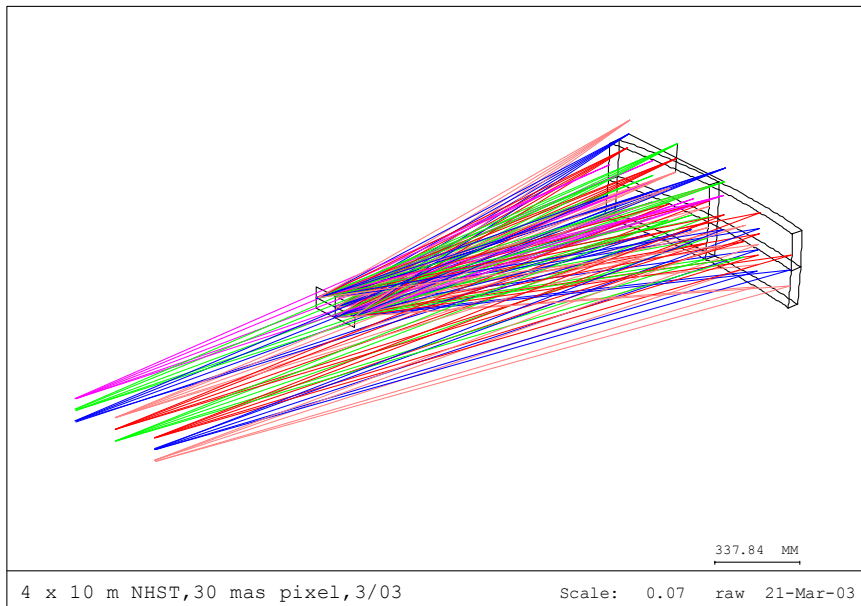
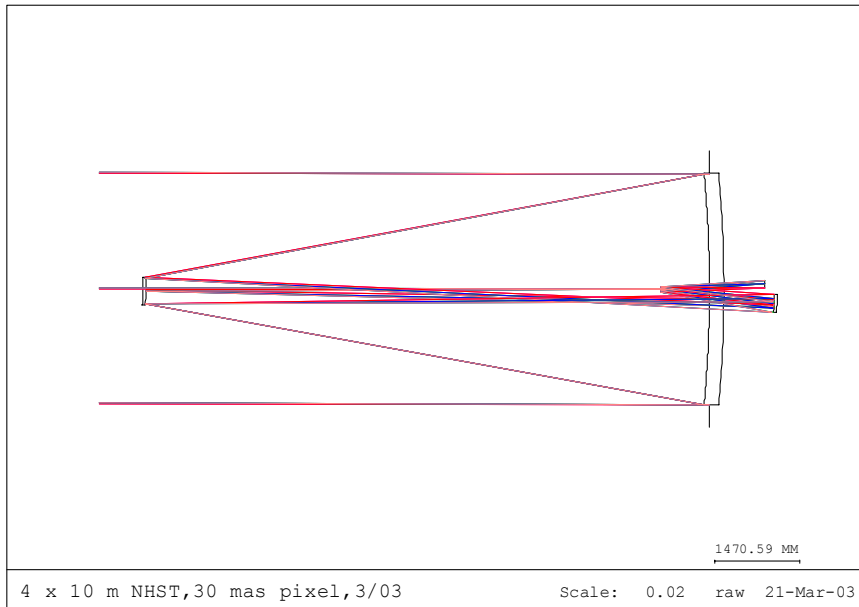

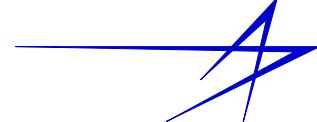

*Typical TMA design:
UV Imager. [uv.3] 25 arc sec
camera with 4 mas pixels.*

*Total FOV available for science
package:
25 arc sec by 12 arc min*

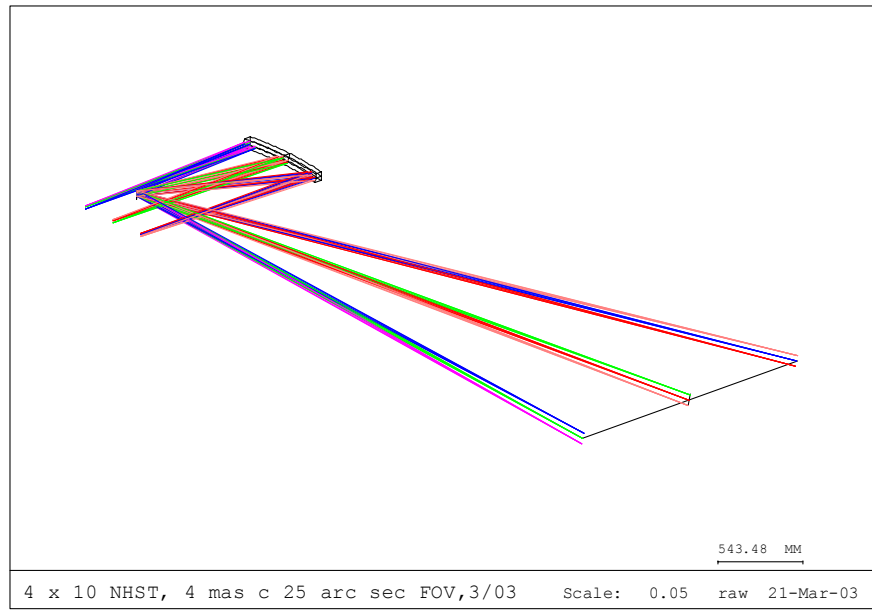
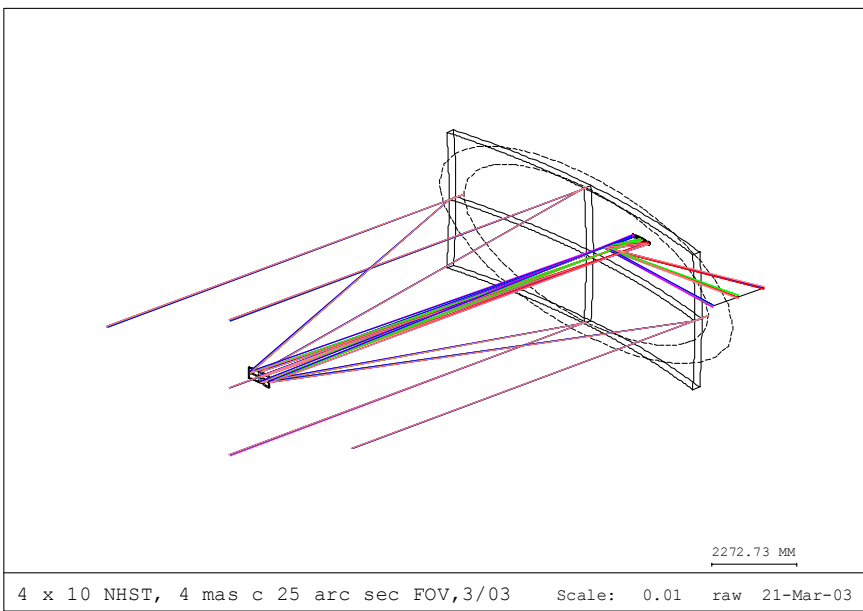
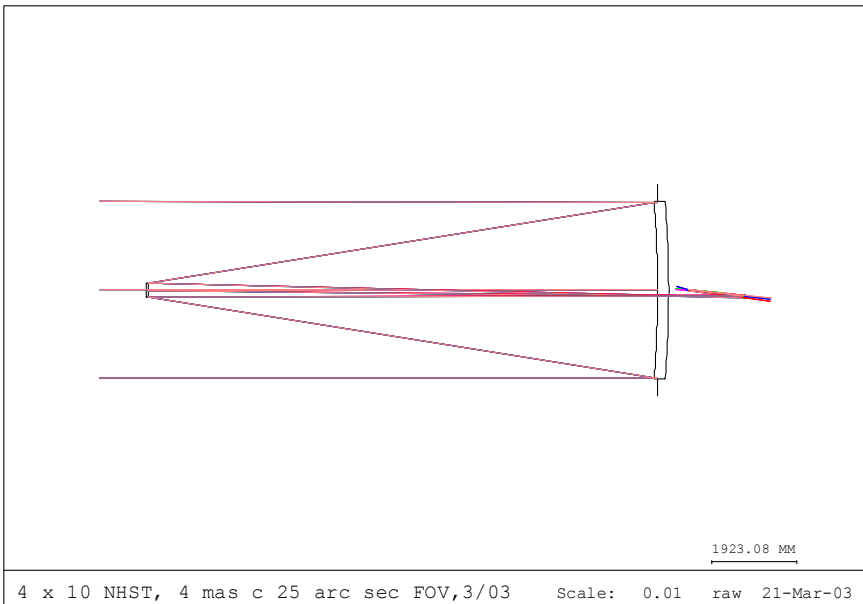

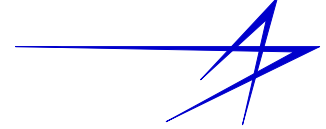

*Ultra WFOV TMA
Like SNAP
1 square degree with 100
mas pixels. (uwfov.1)*

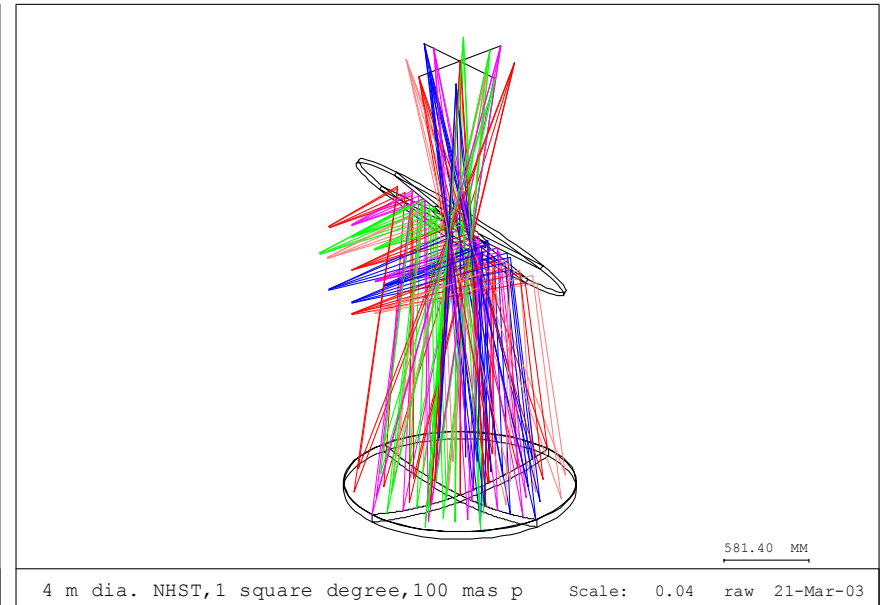
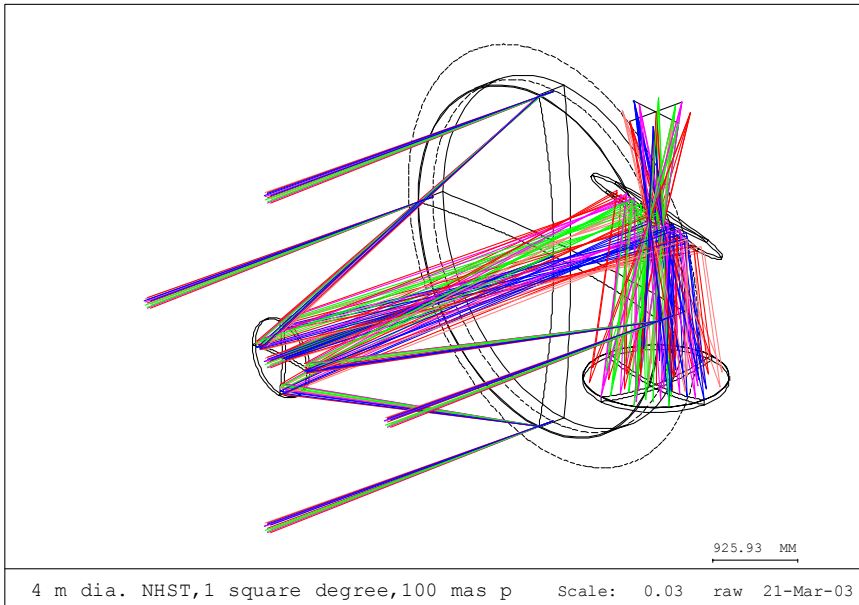
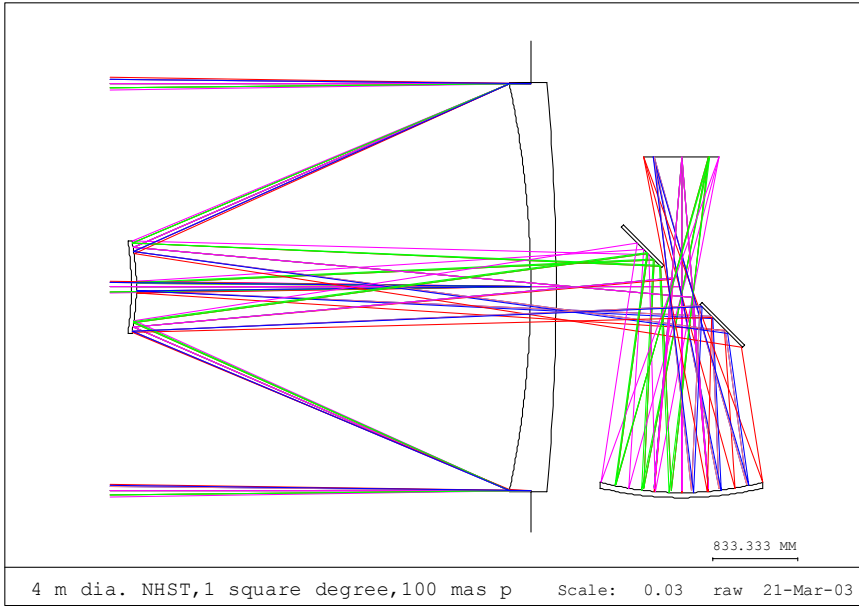



Ultra WFOV with Ritchey Chretien

(90 square arc minute FOV
with RC telescope + relay)

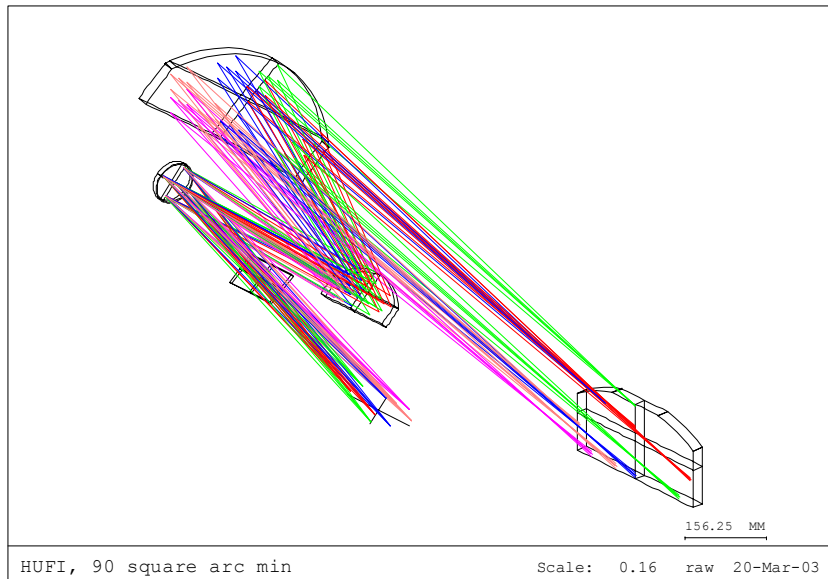
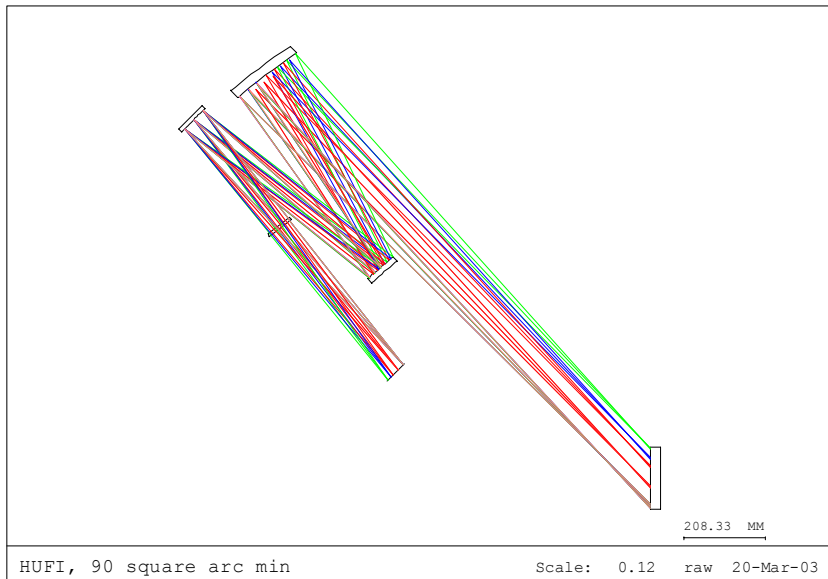
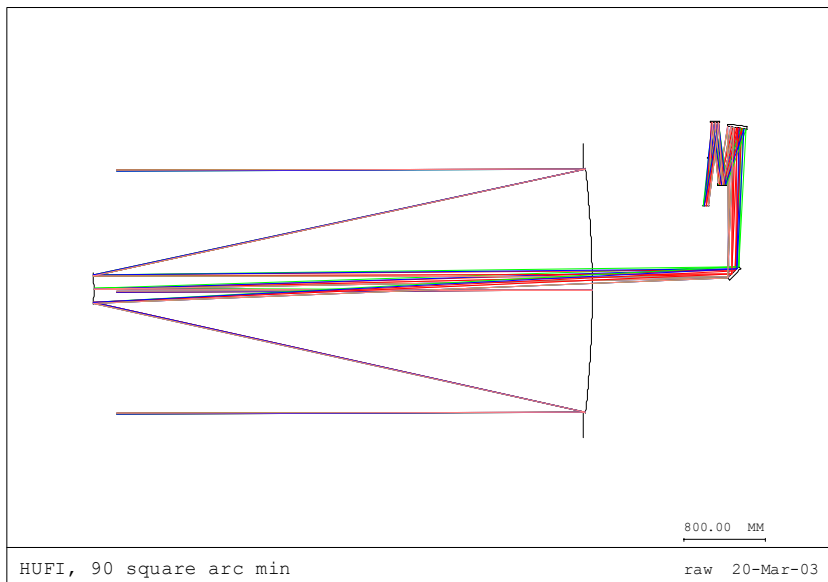

Resultant design forms

- Visible coronagraphy
 - Pupil control important
 - True Cassegrain + Tertiary Mirror
 - Real pupil + field image
 - Off-axis aperture
 - Force actuators on PM (and SM)
 - Precision figured optics
 - Precision alignment: structural and thermal
 - Wavefront Sensing and Control
 - Active CSFR WFS&C
 - Active (or adaptive) LSFR WFC&C
 - LOS jitter control and body pointing
 - Protected Ag or Au ($\lambda > 600$ nm) coating
 - Filters with low red-leak
 - Small FPA: photon counting ideal, sub electron read noise

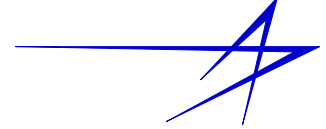

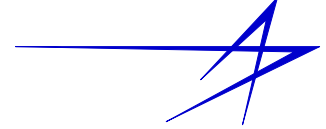

Typical visible Lyot coronagraph design

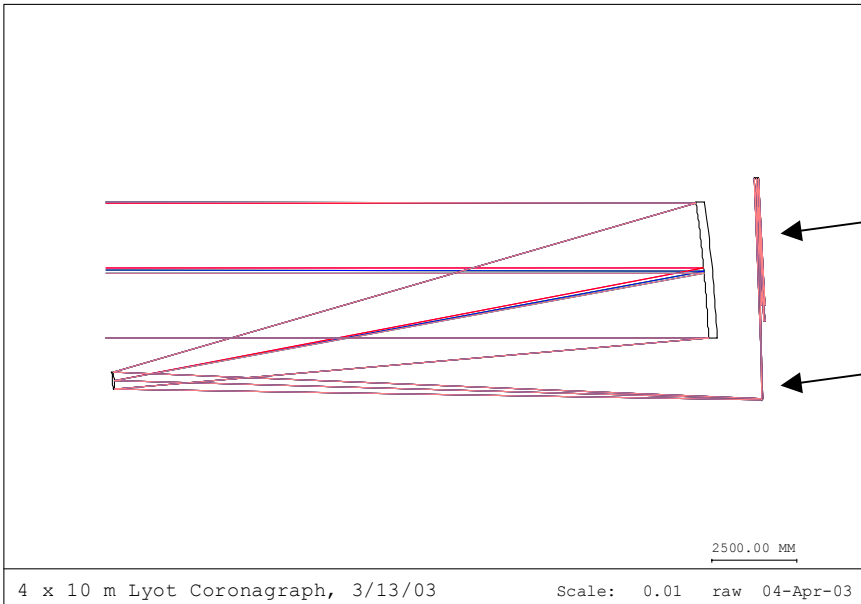
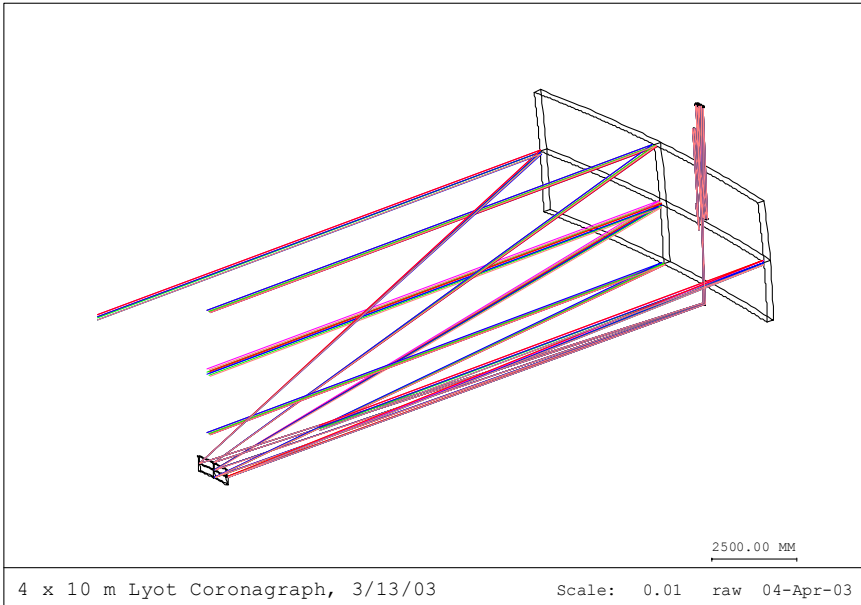

Coronagraph sensor

FSM

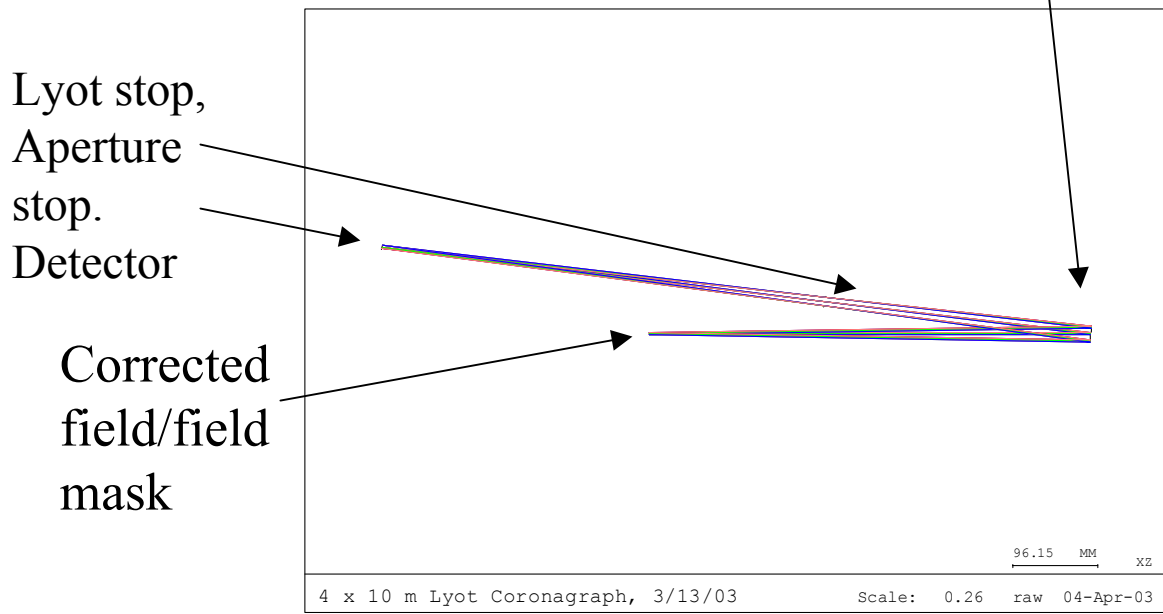
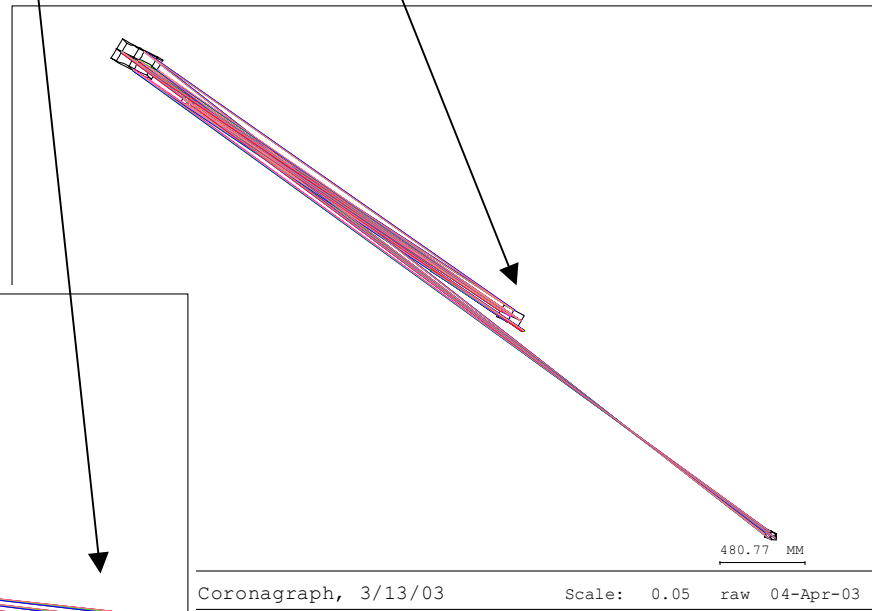
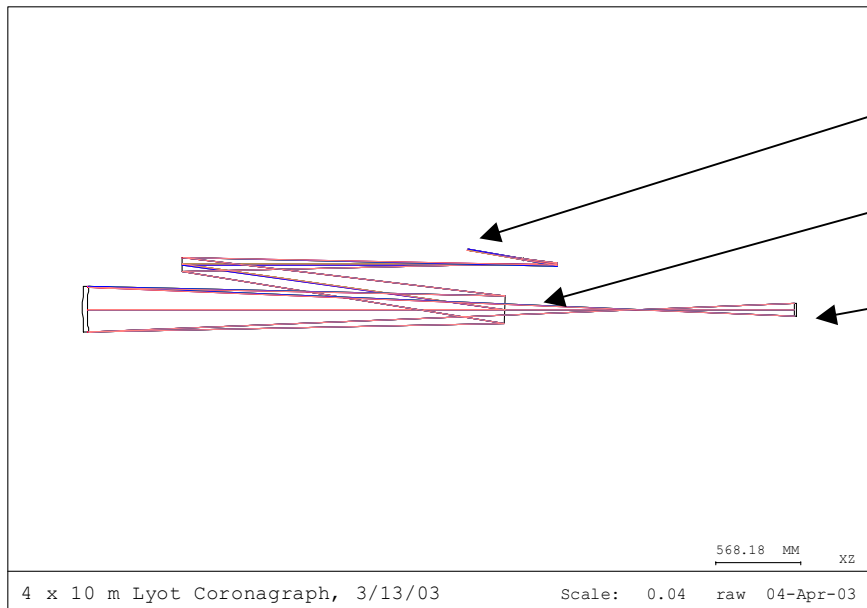
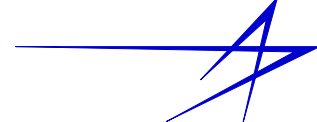

Coronagraph design: pupils and fields



WFE at N CPA ends up in image at N Airy radii:

CSFR range is most critical to coronagraph

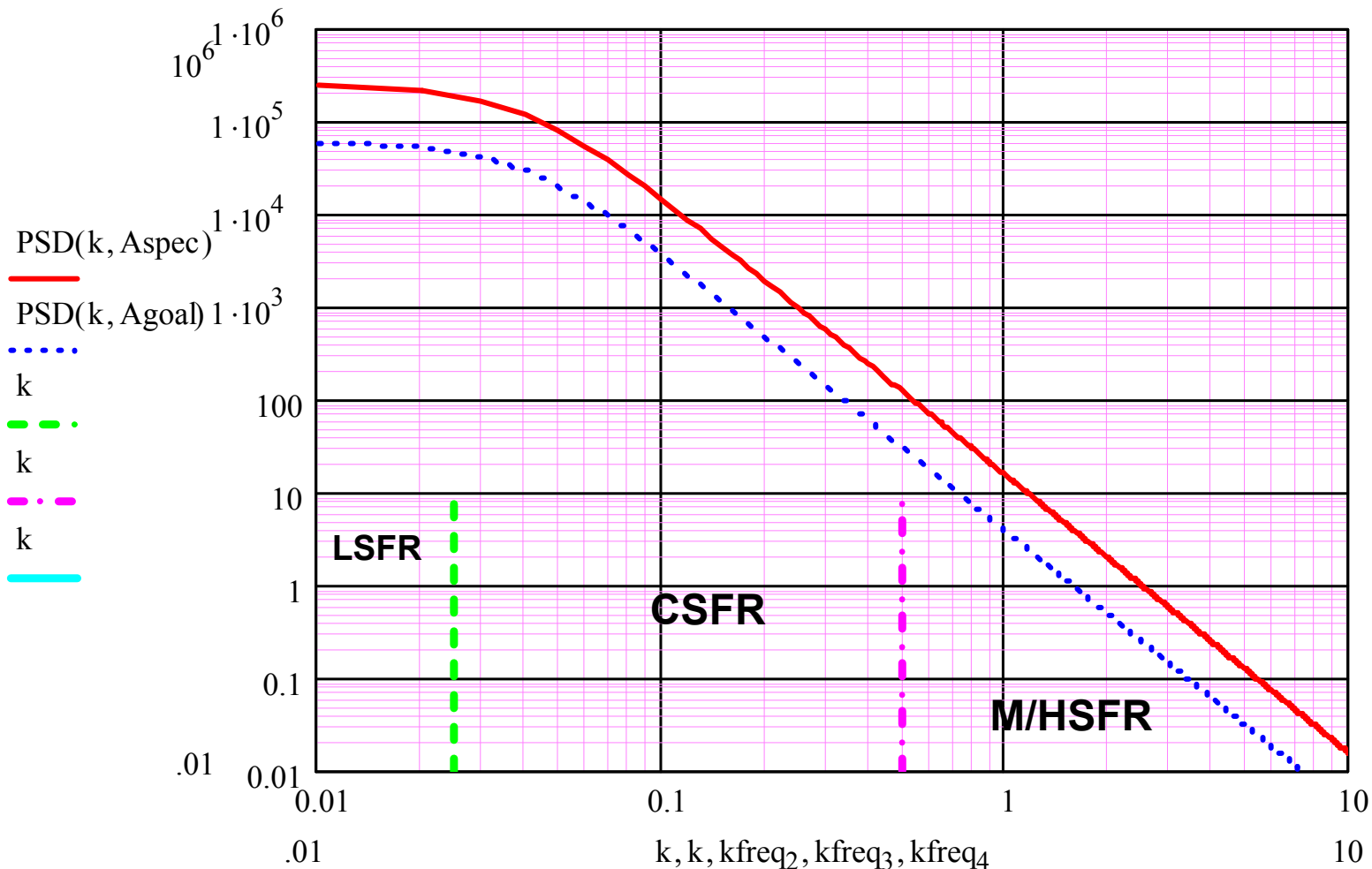



*Typical parameters for
visible
coronagraph ($\lambda=600\text{ nm}$)*

**Increase DM actuator
count to relax WFE**

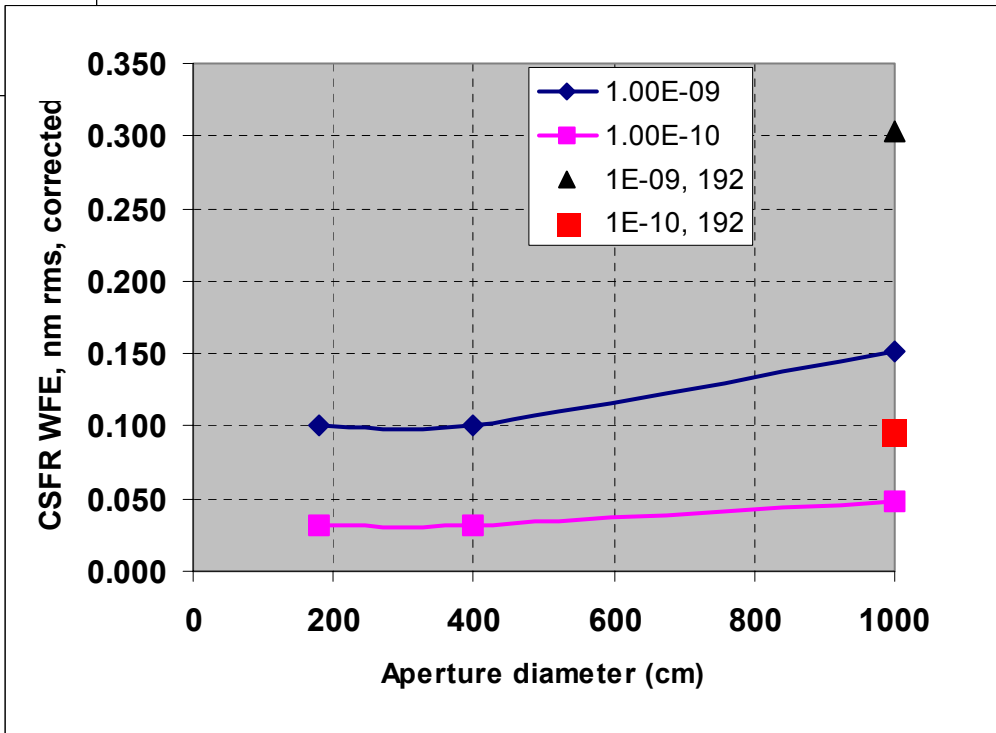
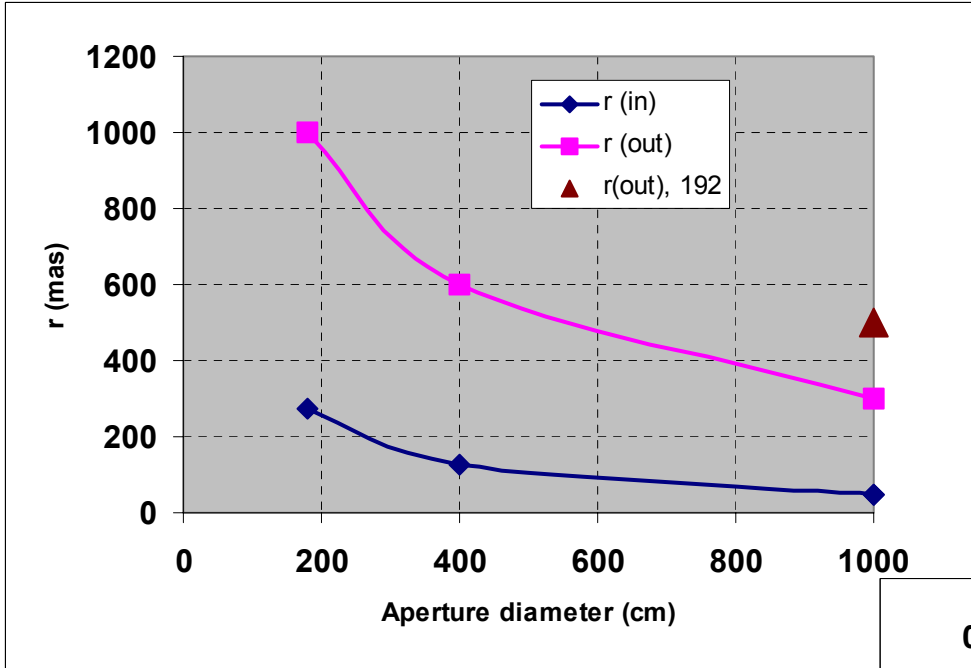

CPA need	r(out) (mas)	Range	r (AU)	λ/D (mas)	r(in) (mas)	DM width (actuators)
14.5	1000	5 pc	5	68.75	275.02	43.6
19.4	600	5 pc	3	30.94	123.76	58.2
24.2	300	10 pc	3	12.38	49.50	72.7
40.4	500	10 pc	5	12.38	49.50	121.2

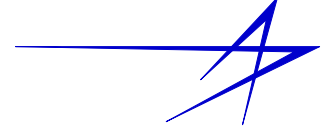

Suitable combinations

- Not combinable
 - UV imager with VWFOV or UWFOV {System trades would allow combination with some loss of UV throughout}
 - Minimize number of mirrors
 - VWFOV with UWFOV
- Combinable
 - UV imager + visible coronagraph
 - VWFOV + visible coronagraph
 - UWFOV + visible coronagraph

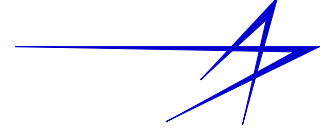

Properties of combined approaches

- UV, Very Wide or Ultra wide field imager would be TMA
- Coronagraph has small FOV
 - Use of PM and TM of TMA
 - Pick-off FOV: Fold beam with FSM to coronagraph dedicated TM
 - Uncorrected image at Cassegrain focus
 - Forms real pupil for DM and corrected field image at CFO

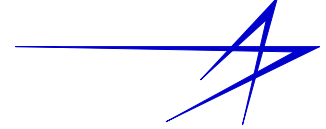

Design issues

- Size
- DM size
- High QE, low noise detectors
- FPA cooling
- Contamination control
- WFE
 - Mirrors
 - Sensing, correction, stability
 - Pupil shear
 - T gradients and level in mirrors
 - Alignment
 - Structural
 - Thermal

Technology categories

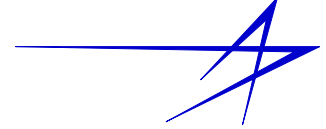

- Large mirrors and structures
- Precise and stable WFE
 - CSFR and overall
 - Components
 - Surface and coatings
 - System
- WFS&C
 - Active and adaptive
 - CSFR and LSFR
 - Phase and amplitude
 - LOS jitter and body point
 - Deformable mirrors
 - Pupil shear
- Filters w/o red leak
- Stray light control
- UV enhanced coatings
- Precision components
 - Field mask
 - Apodizer
- Low noise FPA
 - High QE
 - Large arrays
 - Solar blind UV
- Cooling large arrays
 - Annealing
 - Contamination control
- Calibration
- System test
- Requirement flow-down modeling

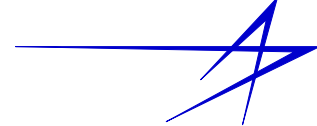

Commonality of critical technologies

	DL wavelength	Array M-pixels	System WFE (nm rms)	System M/CSFR WFE (nm rms)	PM WFE (nm rms)	Structure ΔT lateral (K)	Structure ΔT axial (K)	ΔY SM (microns)	PM ΔT (K)	DM ΔT (K)	Specific features
UV Imager	500 nm	100	36		7	2	0.1	2	1		Very large UV FPA
UV Imager	500 nm	100	36		7	3	0.07	2	1		Very large UV FPA
UV Imager	100 nm	40	7		2	1	0.02	0.7	0.3		
Coronagraph	500 nm	1	2	0.02 to 0.05, 3 to 60 cpa	2	2	0.07	0.5	0.1	0.003	LSFR and CSFR WFS&C, Precise T control and alignment stability
Ultra WFOV	1000 nm	1300	36		14	2	0.2	1	2		Ultra-large FPA/cooling
Common features			Precision components, LSFR WFS&C		Scale up JPL TMD mirror	Orbit, good thermal control	Adaptive LSFR WFS&C, Focus	Adaptive LSFR WFS&C: Coma, astigmatism			

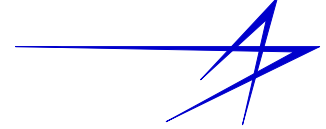

Candidate mission options for NHST

Ultraviolet Imaging

Visible Coronagraphy

Very-wide FOV visible imaging

Ultra-wide FOV visible imaging

- As on HST, other science instrumentation would share the corrected field
 - Spectroscopy, astrometry, photometry, etc.
- Capability can be implemented to accomplish most desirable science
- Parallel, coordinated design studies and technology development can support multiple potential capabilities

LOCKHEED MARTIN

