

October 2002

Hubble Space Telescope Primer for Cycle 12

An Introduction to HST for Phase I Proposers

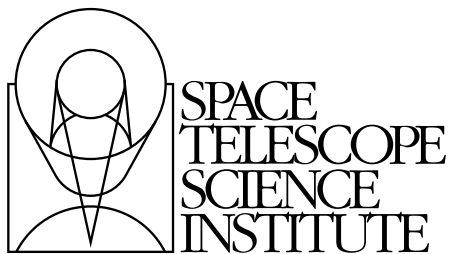

Space Telescope Science Institute
3700 San Martin Drive
Baltimore, Maryland 21218
help@stsci.edu

How to Get Started

If you are interested in submitting an HST proposal, then proceed as follows:

- Visit the Cycle 12 Announcement Web Page:
<http://www.stsci.edu/ftp/proposer/cycle12/announce.html>
- Read the Cycle 12 Call for Proposals.
- Read this HST Primer.

Then continue by studying more technical documentation, such as that provided in the Instrument Handbooks, which can be accessed from

http://www.stsci.edu/hst/HST_overview/documents.

Where to Get Help

- Visit STScI's Web Site at <http://www.stsci.edu>.
- Contact the STScI Help Desk. Either send e-mail to help@stsci.edu or call 1-800-544-8125; from outside the United States, call [1] 410-338-1082.

The HST Primer for Cycle 12 was edited by

Ron Downes and Susan Rose,

based in part on versions from previous cycles, and with text and assistance from many different individuals at STScI.

Send comments or corrections to:
Space Telescope Science Institute
3700 San Martin Drive
Baltimore, Maryland 21218
E-mail:help@stsci.edu

Table of Contents

Chapter 1: Introduction	1
1.1 About this Document.....	1
1.2 Resources, Documentation and Tools.....	2
1.2.1 Cycle 12 Announcement Web Page.....	2
1.2.2 Cycle 12 Call for Proposals	2
1.2.3 Instrument Handbooks	2
1.2.4 The Astronomer’s Proposal Tool (APT).....	3
1.2.5 Exposure Time Calculators (ETCs)	3
1.2.6 The Visual Target Tuner (VTT).....	3
1.2.7 HST Data Archive	4
1.2.8 Data Reduction and Calibration.....	4
1.3 STScI Help Desk.....	4
1.4 Organization of this Document	5
Chapter 2: System Overview	7
2.1 Hubble Space Telescope Operations	7
2.1.1 Servicing Mission SM1	8
2.1.2 Servicing Mission SM2	8
2.1.3 Servicing Missions SM3A and SM3B	8
2.1.4 Servicing Mission SM3A.....	9
2.1.5 Servicing Mission SM3B.....	9
2.1.6 Servicing Mission SM4	10
2.2 Telescope Design and Field of View.....	10
2.3 Orbital Constraints	13
2.3.1 Continuous Viewing Zone (CVZ)	13
2.3.2 South Atlantic Anomaly (SAA).....	14
2.3.3 Predicted HST Position	15
2.4 Pointing Constraints	15
2.5 Orientation and Roll Constraints	16

2.6 Data Storage and Transmission	17
2.6.1 Real-time Contact Requests.....	17
2.6.2 Onboard Data Storage	17
Chapter 3: Telescope Performance	19
3.1 Optical Performance.....	19
3.2 HST Guiding Performance.....	20
3.2.1 FGS - Dual Guide Star Acquisitions	20
3.2.2 FGS - Single Guide Star Acquisitions.....	20
3.2.3 Gyro-only Pointing Control	21
3.3 HST Observing Efficiency	21
Chapter 4: Cycle 12 Scientific Instruments	23
4.1 Overview	24
4.1.1 Instrument Comparison	27
4.1.2 Future Instruments.....	29
4.2 Advanced Camera for Surveys (ACS)	31
4.3 Fine Guidance Sensor (FGS1R)	32
4.4 Near Infrared Camera and Multi-Object Spectrometer (NICMOS).....	32
4.4.1 Camera Focusing	33
4.4.2 Dark Levels.....	33
4.4.3 South Atlantic Anomaly (SAA) Cosmic Ray Persistence	34
4.5 Space Telescope Imaging Spectrograph (STIS).....	34
4.6 Wide Field and Planetary Camera 2 (WFPC2)	35
Chapter 5: Observing Considerations	37
5.1 Bright-Object Constraints	37
5.1.1 NICMOS & WFPC2	37
5.1.2 ACS & STIS	38
5.1.3 FGS	38
5.2 Target Acquisitions	38
5.2.1 Target Acquisition without the Ground System	39
5.2.2 Target Acquisition with the Ground System	39
5.3 Solar-System Targets	40

5.4 Offsets and Patterns.....	41
5.5 Special Background Emission Requirements	41
5.5.1 Low-Sky (LOW) Observations	41
5.5.2 Shadow (SHD) Observations	42
Chapter 6: Orbit Calculation for a Phase I Proposal	43
6.1 Construction of an Observing Program	43
6.1.1 General Observer (GO) Programs.....	43
6.1.2 Snapshot Programs.....	45
6.2 HST Visits	45
6.2.1 When is a New Visit Required?	45
6.2.2 Maximum Duration of a Visit.....	45
6.2.3 Instrument Specific Limitations on Visits	46
6.3 The Visibility Period	48
6.4 Acquisition Times and Instrument Overheads	50
6.4.1 Guide Star Acquisition Times	50
6.4.2 Target Acquisition Times	50
6.4.3 Instrument Overhead Times	52
6.4.4 Telescope Repositioning Overhead Times.....	57
6.5 Constructing Your Program.....	58
Chapter 7: Data Processing and the HST Data Archive	59
7.1 Routine Science Data Processing	59
7.1.1 Space Telescope Science Data Analysis System (STSDAS).....	60
7.2 The HST Data Archive.....	60
7.2.1 StarView and Web Access to the HST Data Archive.....	61

Appendix A: Orbit Calculation

Examples	63
A.1 ACS	63
A.2 FGS	65
A.3 NICMOS	67
A.4 STIS	69
A.5 WFPC2	70

Appendix B: Archival Instruments..... 73

B.1 Faint Object Camera (FOC)	73
B.2 Faint Object Spectrograph (FOS)	74
B.3 Goddard High Resolution Spectrograph (GHRS)	75
B.4 High Speed Photometer (HSP)	76
B.5 Wide Field and Planetary Camera 1 (WF/PC)	76

Appendix C: Glossary of Acronyms and Abbreviations 77 |

Appendix D: Internet Links..... 81

Introduction

In this chapter . . .

1.1 About this Document / 1
1.2 Resources, Documentation and Tools / 2
1.3 STScI Help Desk / 4
1.4 Organization of this Document / 5

1.1 About this Document

This Primer provides an introductory overview of the Hubble Space Telescope (HST), and contains basic information on the telescope's operations and the unique capabilities of its instruments. While the Primer is of interest to anyone who wants to learn about HST, it is intended to be a companion document to the Call for Proposals (see Section 1.2). The Call for Proposals discusses the policies and procedures for submitting a Phase I proposal for HST observing or Archival Research. Technical aspects of proposal preparation are presented in this Primer, and a thorough understanding of the material presented here is essential for the preparation of a competitive proposal. Also, this Primer explains how to calculate the appropriate number of orbits for your Phase I observing time requests.

The Primer is only available electronically in HTML and PDF formats. The HTML version is optimized for on-line browsing, and contains many links to related or more detailed information, both within the document itself and within other STScI documents. You are therefore encouraged to use the HTML version electronically. Nonetheless, some people may prefer

to read a hardcopy, and with this in mind, the PDF version was optimized for printing.

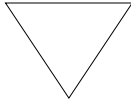

In a hardcopy printout of the PDF version, any links to information on the internet will appear as underlined text. You can look up the internet address of the corresponding link in Appendix D.

1.2 Resources, Documentation and Tools

1.2.1 Cycle 12 Announcement Web Page

The Cycle 12 Announcement Web Page contains links to information and documentation (including this Primer) that will be of use to you in the preparation of an HST proposal. It also contains any late-breaking updates on the Phase I process, and answers to frequently asked questions.

1.2.2 Cycle 12 Call for Proposals

The Call for Proposals discusses the policies and procedures for submitting a Phase I proposal for HST observing or Archival Research. It also provides a summary of the proposal process, from proposal submission to execution of the observations. The Call for Proposals is accessible from the Cycle 12 Announcement Web Page.

1.2.3 Instrument Handbooks

The Instrument Handbooks are the primary source of information for the HST instruments. You should consult them for any information that goes beyond what is presented in this Primer. Please use current versions when preparing your Phase I proposal. They are available for all instruments, including former instruments that may be of interest for Archival Research. The Handbooks are distributed electronically, and can be accessed from the Scientific Instruments Web Page. This page also provides links to more detailed technical information, such as that provided in Instrument Science Reports.

1.2.4 The Astronomer's Proposal Tool (APT)

In a continuing effort to streamline our systems and improve service to the science community, STScI has developed and released APT: the Astronomer's Proposal Tool. This java-based software tool is the new interface for all Phase I and Phase II proposal submissions for HST. It brings state of the art technology and more visual tools into the hands of proposers to optimize the scientific return of their programs. The APT Web Page contains information on the installation and use of APT.

1.2.5 Exposure Time Calculators (ETCs)

STScI provides Exposure Time Calculators (ETCs) for each of the HST instruments. Please use these electronic tools to estimate how long you need to integrate to achieve the signal-to-noise ratio required for your project. The ETCs will also issue warnings about target count rates that exceed linearity and safety limits. The ETCs can be accessed from the individual instrument web pages, which in turn are accessible from the [Scientific Instruments Web Pages](#). The ETCs for ACS, NICMOS, and STIS are also included in the Astronomer's Proposal Tool (APT) software package (see Section 1.2.4).

1.2.6 The Visual Target Tuner (VTT)

The Visual Target Tuner (VTT) displays HST apertures and fields of view that are superimposed on sky images. The VTT is available as a stand alone tool with the Astronomer's Proposal Tool (APT) software package. Detailed information about the VTT is accessible from the [APT](#) web page.

The VTT can be useful in Phase I proposal preparation to help answer questions such as: How many exposures will I need to mosaic my extended target? Which of my potential targets "fits best" in the aperture? Is there anything interesting I can observe with a coordinated parallel in another aperture? Do any of my potential targets have nearby bright objects that could spoil the observation? Is there an orientation which would avoid the bright object?

The VTT also includes an interface to the Starview (the HST archive software). This means you to invoke the VTT from Starview to graphically represent Starview results on what areas of the sky have been previously been observed. Conversely you can call up Starview from the VTT to show what observations have been made near a particular pointing.

1.2.7 HST Data Archive

The HST Data Archive (see the [Data Handbook](#)) forms a part of the Multimission Archive at STScI (MAST). The HST Data Archive contains all the data taken by HST. Completed HST observations from both GO and GTO programs are available to the community upon the expiration of their proprietary periods. Observations taken under the Treasury and public parallel programs carry no proprietary period.

The [MAST Web Page](#) provides an overview of the HST Data Archive, as well as the procedures for retrieving archival data (see also Section 7.2). A copy of the HST Data Archive is maintained at the [Space Telescope - European Coordinating Facility \(ST-ECF\)](#) in Garching, to which European requests should normally be addressed. The [Canadian Astronomy Data Centre](#) also maintains a copy of HST science data (only), and is the preferred source for Canadian astronomers. The National Astronomical Observatory of Japan (NAOJ) maintains a nearly complete copy of the public HST science data, and should provide faster access for astronomers in Pacific rim nations. However, the NAOJ site may not have all public data available.

1.2.8 Data Reduction and Calibration

The HST [Data Handbook](#) describes the data that are produced by the instruments; the ACS Data Handbook Primer will be available to support the Phase II submission. The [Space Telescope Science Data Analysis Software \(STSDAS\) Web Page](#) has links to the software that is used to calibrate and analyze HST data, and to documentation on its use. See Section 7.1 for details.

1.3 STScI Help Desk

If this HST Primer and the materials referenced above do not answer your questions, or if you have trouble accessing or printing Web documents, then contact the Help Desk. You can do this in either of two ways:

- Send e-mail to help@stsci.edu
- Call 1-800-544-8125, or from outside the United States, [1] 410-338-1082.

1.4 Organization of this Document

Chapter 2 provides a system overview of HST. Chapter 3 discusses the performance of the telescope. Chapter 4 provides information on the Scientific Instruments available for use in Cycle 12. Chapter 5 discusses a variety of issues, such as Bright Object constraints, relevant to the preparation and execution of HST observations. Chapter 6 explains how to calculate the appropriate orbit resources to request in a Phase I observing proposal, and Chapter 7 discusses data processing and the HST Data Archive.

A variety of additional information is provided in the Appendices, including examples of Phase I orbit calculations for each of the Cycle 12 instruments (Appendix A), descriptions of former HST instruments that may be of interest for Archival Research (Appendix B), a glossary of acronyms and abbreviations (Appendix C) and a listing of internet links used in the document (Appendix D).

System Overview

In this chapter . . .

2.1 Hubble Space Telescope Operations / 7
2.2 Telescope Design and Field of View / 10
2.3 Orbital Constraints / 13
2.4 Pointing Constraints / 15
2.5 Orientation and Roll Constraints / 16
2.6 Data Storage and Transmission / 17

2.1 Hubble Space Telescope Operations

The Hubble Space Telescope is a cooperative project of the National Aeronautics and Space Administration (NASA) and the European Space Agency (ESA) to operate a long-lived space-based observatory for the benefit of the international astronomical community. HST was first dreamt of in the 1940s, and designed and built in the 1970s and 80s. In April 1990 the Space Shuttle Discovery deployed it in low-Earth orbit (~600 kilometers). The initial complement of Scientific Instruments (SIs) was:

- The Fine Guidance Sensors (FGSs).
- The Faint Object Camera (FOC).
- The Faint Object Spectrograph (FOS).
- The Goddard High Resolution Spectrograph (GHRS).
- The High Speed Photometer (HSP).
- The Wide Field and Planetary Camera (WF/PC).

Soon after deployment it was discovered that the primary mirror suffers from spherical aberration, which limited the quality of HST data obtained in the first few years of operation.

2.1.1 Servicing Mission SM1

During servicing mission SM1 in December 1993, Space Shuttle astronauts successfully refurbished HST. They replaced the HSP with COSTAR, a corrective optics package. COSTAR's reflecting optics were deployed into the optical paths of the FOC, FOS and GHRS, which removed the effects of the primary mirror's spherical aberration. The performance of the FGSs was unaffected by COSTAR. The WF/PC was replaced by a new instrument:

- The Wide Field and Planetary Camera 2 (WFPC2).

The WFPC2 contains its own internal optics to correct the spherical aberration.

The astronauts also installed new solar arrays. This resolved the problem of the thermal vibrations of the old arrays during day/night transitions, which had affected the telescope's pointing performance.

2.1.2 Servicing Mission SM2

During servicing mission SM2 in February 1997, astronauts replaced the FOS and the GHRS with two new instruments:

- The Near Infrared Camera and Multi-Object Spectrometer (NICMOS).
- The Space Telescope Imaging Spectrograph (STIS).

Also, FGS-1 was replaced with an enhanced FGS, called FGS1R. FGS1R has an adjustable fold flat mirror, which is commandable from the ground. This enables realignment in the FGS optical path to lessen the effects of the primary mirror's spherical aberration. As a result, the astrometric performance of FGS1R significantly exceeds that of the original FGS.

2.1.3 Servicing Missions SM3A and SM3B

HST has six rate-sensing gyroscopes on board; three of these gyroscopes must be in working order to maintain accurate pointing. In the years after SM2, gyroscopes failed at a higher than expected rate, ultimately leading to a halt of HST observing in November 1999. In anticipation of this event, servicing mission SM3, which had been in planning for several years, was split into two separate missions: SM3A and SM3B.

2.1.4 Servicing Mission SM3A

In December 1999 Space Shuttle astronauts lifted off for servicing mission SM3A. Six new gyroscopes were successfully installed, which allowed HST to resume normal operations.

Along with the gyro replacements, the HST Project used this “unplanned” mission to make other planned upgrades and refurbishments:

1. Voltage/temperature Improvement Kits (VIKs) were installed to help regulate battery recharge voltages and temperatures.
2. The original DF224 spacecraft computer was replaced by a 486 upgrade, which provides a significant improvement in onboard computing power.
3. The FGS2 was replaced by a refurbished fine guidance sensor FGS2R, to enhance the performance of the pointing and control system (see Section 2.1.2).
4. The second tape recorder was replaced by a second Solid State Recorder (SSR), and a new transmitter was installed to replace one that had failed.

All of the upgrades underwent successful in-orbit verification and calibration and the observatory’s functionality was completely restored according to plan.

2.1.5 Servicing Mission SM3B

Servicing Mission 3B was carried out the first ten days of March 2002. During this mission, astronauts replaced the FOC with a new instrument:

- The Advanced Camera for Surveys (ACS).

Also, the astronauts installed the NICMOS Cooling System (NCS) to allow further use of NICMOS, which had exhausted its cryogen in January 1999. Installation of new solar arrays, electrical upgrades to the spacecraft’s power control unit, along with various other engineering upgrades, including an orbit reboost, were performed. Since the mission, the ACS and the NICMOS instruments, as well as STIS and WFPC2, have been fully commissioned for science.

2.1.6 Servicing Mission SM4

In the final servicing mission SM4, currently planned for mid-2004, Space Shuttle astronauts will replace COSTAR and WFPC2 with the last two instruments that are planned for use on HST:

- The Cosmic Origins Spectrograph (COS).
- The Wide Field Camera 3 (WFC3).

In addition to these scientific enhancements, the planned upgrades include the Aft Shroud Cooling System (ASCS), which will provide enhanced thermal control for axial instruments, a refurbished Fine Guidance Sensor (FGS), the complete replacement of both the battery and gyro complements and various other engineering upgrades.

2.2 Telescope Design and Field of View

The design and layout of HST are shown schematically in Figure 2.1. The telescope receives electrical power from two solar arrays, which are turned (and the spacecraft rolled about its optical axis) so that the panels face the incident sunlight. Nickel-hydrogen batteries power the telescope during orbital night. Two high-gain antennas provide communications with the ground via the Tracking and Data Relay Satellite System (TDRSS). Power, control and communications functions are carried out by the Support Systems Module (SSM) that encircles the primary mirror.

The SIs are mounted in bays behind the primary mirror. The WFPC2 occupies one of the radial bays, with an attached 45 degree pickoff mirror that allows it to receive the on-axis beam. There are three Fine Guidance Sensors (FGSs) which occupy the other radial bays and receive light 10–14 arcminutes off-axis. Since at most two FGSs are required to guide the telescope, it is possible to conduct astrometric observations with the third FGS. The remaining SIs are mounted in the axial bays and receive images several arcminutes off-axis.

When referring to the HST and its focal plane, we use a coordinate system that is fixed to the telescope and consists of three orthogonal axes: U_1 , U_2 and U_3 . As shown in Figure 2.1, U_1 lies along the optical axis, U_2 is parallel to the solar-array rotation axis, and U_3 is perpendicular to the solar-array axis. (Note: Some HST documentation uses the alternative V_1 , V_2 , V_3 coordinate system for which $V_1=U_1$, $V_2=-U_2$ and $V_3=-U_3$.)

Figure 2.1: The Hubble Space Telescope. Major components are labelled, and definitions of the U1,U2,U3 spacecraft axes are indicated.

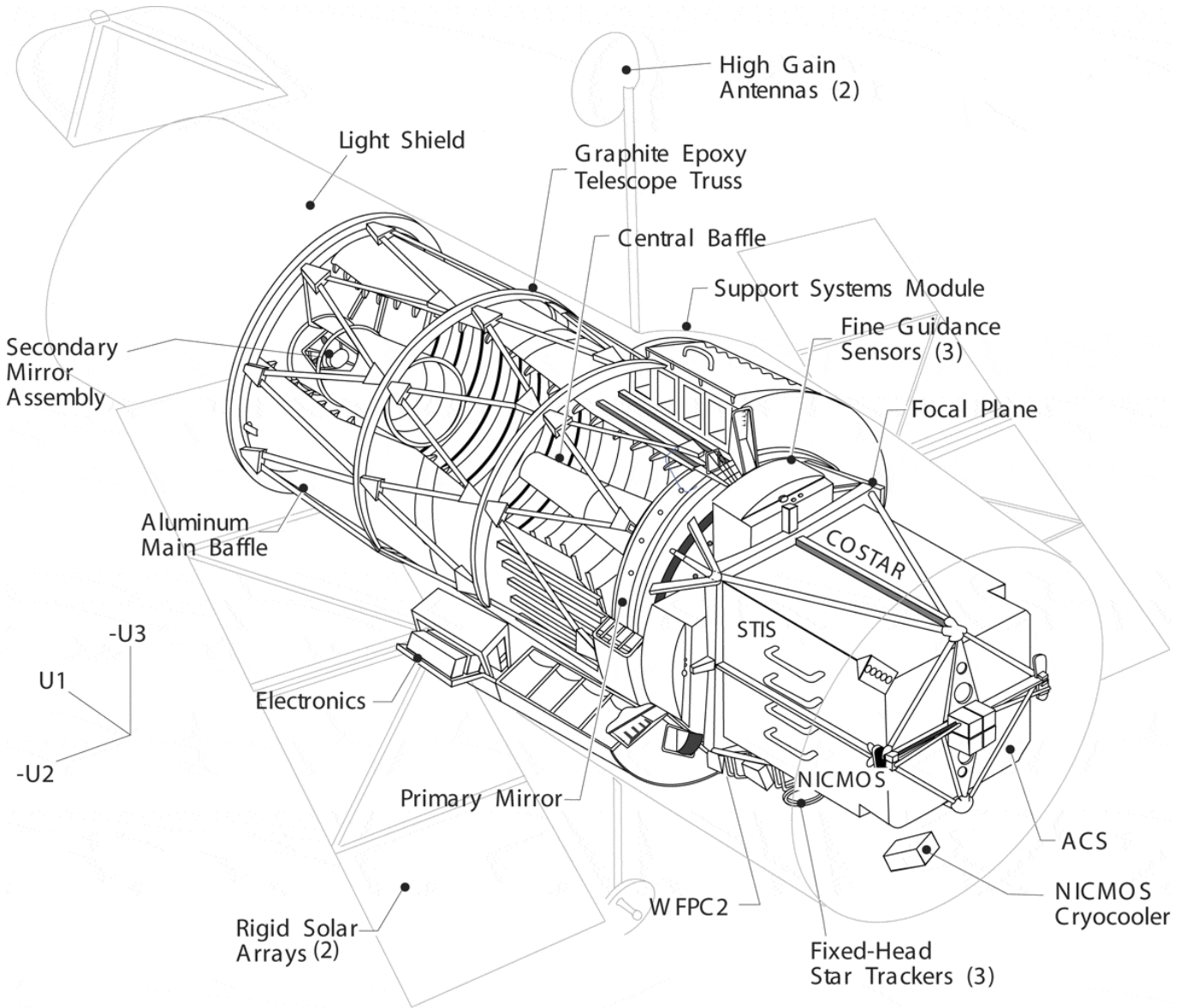

Figure 2.2: The HST field of view with the locations of the SI and the FGS apertures in the (U2,U3) focal plane. The scale in arcsec is indicated.

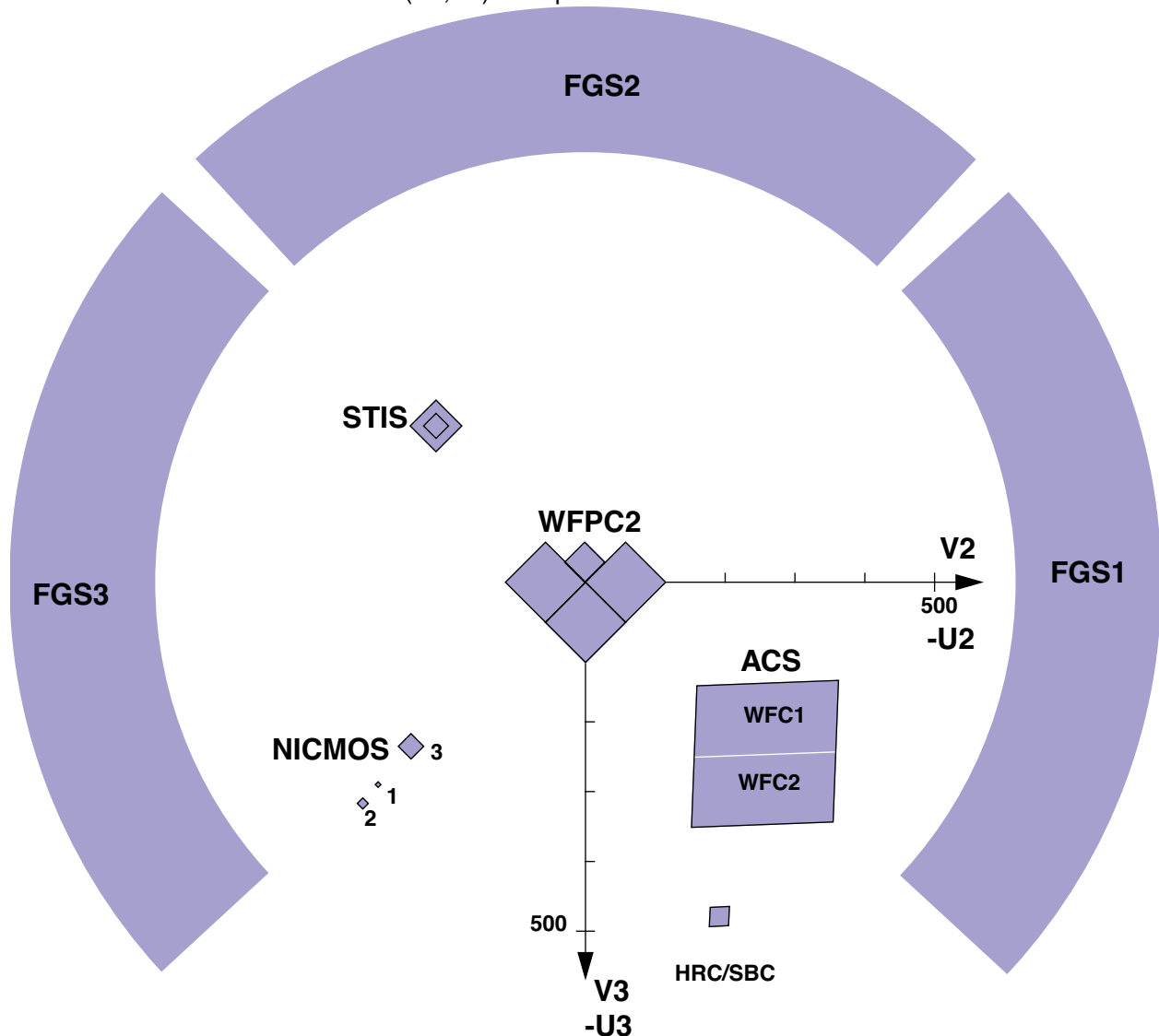

Figure 2.2 shows the layout of the instrument entrance apertures in the telescope focal plane, as projected onto the sky.

Table 2.1 lists the relative effective locations of the SI apertures in the U2,U3 coordinate system; linear dimensions were converted to arcseconds using a plate scale of 3.58 arcsec/mm, which yields aperture locations accurate to about +/- 1 arcsec. The [Instrument Handbooks](#) (see Section 1.2) should be consulted for accurate details of each instrument's aperture sizes and orientations.

Table 2.1: Nominal Effective Relative Aperture Locations

Instrument	Aperture	U2 (arcsec)	U3 (arcsec)
ACS	WFC	-258	-238
	HRC	-207	-471
	SBC	-206	-469
FGS	FGS1R	-726	0
NICMOS	NIC1	296	-290
	NIC2	319	-311
	NIC3	249	-235
STIS		214	225
WFPC2	PC	-2	30
	WF2	51	6
	WF3	0	-48
	WF4	-55	6

2.3 Orbital Constraints

HST is in a relatively low orbit, which imposes a number of constraints upon its observations. As seen from HST, most targets are occulted by the Earth for varying lengths of time during each 96-minute orbit. Targets lying in the orbital plane are occulted for the longest interval—about 44 minutes per orbit. These orbital occultations—analogueous to the diurnal cycle for ground-based observing—impose the most serious constraint on HST observations. (Note that in practice the amount of available exposure time in an orbit is limited further by Earth-limb avoidance limits, the time required for guide-star acquisitions or re-acquisitions, and instrument overheads.)

2.3.1 Continuous Viewing Zone (CVZ)

The length of target occultation decreases with increasing angle from the spacecraft orbital plane. Targets lying within 24 degrees of the orbital poles are not geometrically occulted at all during the HST orbit. This gives rise to so-called Continuous Viewing Zones (CVZs). The actual size of these zones is less than 24 degrees, due to the fact that HST cannot observe close to the Earth Limb (see Section 2.4).

Since the orbital poles lie 28.5 degrees from the celestial poles, any target located in two declination bands near ± 61.5 degrees may be in the CVZ at some time during the 56-day HST precessional cycle. Some regions in

these declination bands can be unusable during the part of the year when the sun is too close to the region. Depending upon the telescope orbit and the target position, there are typically 7 CVZ intervals with durations ranging from 1 to 105 orbits (7 days). Check the [CVZ Tables on the Web](#) to determine the number of CVZ opportunities in Cycle 12 and their duration for a given target location. The South Atlantic Anomaly (SAA; see Section 2.3.2) limits any *uninterrupted* observation to no more than 5-6 orbits.

The brightness of scattered Earthshine background during CVZ observations is not greater than during non-CVZ observations, since the same bright-earth limb avoidance angle is used. However, the duration of relatively high background can be much longer for CVZ observations than for non-CVZ observations, because the line of sight may continuously graze the bright earth-limb avoidance zone during CVZ observations.

In general, CVZ should not be requested if observations are sky-background limited under normal observing conditions. The increased earthshine means that the CVZ offers virtually no efficiency gain for programs doing background-limited broadband imaging in the optical or infrared. There have been cases in the past (e.g. the Hubble Deep Field observations) where optical imaging has been interleaved with other kinds of observations. However such observations are difficult to schedule and require strong science justification. Observers contemplating using CVZ in this way are encouraged to contact the [STScI Help Desk](#) (see Section 1.3) prior to proposing. CVZ observations are also generally incompatible with special timing requirements (e.g., timing links, special spacecraft orientations, or targets of opportunity; see [Section 4.1.1 of the Call for Proposals](#) for more details).

2.3.2 South Atlantic Anomaly (SAA)

The South Atlantic Anomaly, a lower extension of the Van Allen radiation belts, lies above South America and the South Atlantic Ocean. No astronomical or calibration observations are possible during passages of the spacecraft through the SAA because of the high background induced in the science instruments and FGSs. As the HST orbit precesses and the earth rotates during the day, the southern part of the HST orbit intersects the SAA for 7 to 9 orbits in a row (so-called “SAA-impacted” orbits). These SAA-impacted orbits are followed by 5 to 6 orbits (8 to 10 hours) without SAA intersections. During intersections, HST observing activities must be halted for approximately 20 to 25 minutes. This effectively limits the longest possible uninterrupted observations, *even in the CVZ*, to 5 orbits.

2.3.3 Predicted HST Position

Because HST's orbit is low, atmospheric drag is significant. Moreover, the amount of drag varies depending on the orientation of the telescope and the density of the atmosphere, which in turn depends on the level of solar activity. Consequently, it is difficult to predict in advance where HST will be in its orbit at a given time. For example, the predicted position of the telescope made two days in advance can be off by as much as 30 km from its actual position. An estimated position 44 days in the future may be off by ~4000 km (95% confidence level).

This positional uncertainty can affect observations of time-critical phenomena, and also those of near-earth solar-system bodies. In the former case the target could be behind the Earth at the time of the event, and it may not be known if a given event will be observable until a few days before the observation. In the latter case the positional uncertainty could introduce uncertainties in the parallax correction.

2.4 Pointing Constraints

HST uses electrically driven reaction wheels to perform all slewing required for guide-star acquisition and pointing control. A separate set of rate gyroscopes provides attitude information to the pointing control system (PCS). The slew rate of HST is limited to approximately 6 degrees per minute of time. Consequently, about one hour is needed to go full circle in pitch, yaw or roll. After the telescope arrives at the new target, the FGSs will take up to 8 additional minutes to acquire a pair of guide stars. As a result, large maneuvers are costly in time and are generally scheduled for periods of Earth occultation or crossing of the South Atlantic Anomaly (see Section 2.3.2).

During normal operations, the telescope does not observe targets that are

- within 50 degrees of the Sun;
- within 15.5 degrees of any illuminated portion of the Earth;
- within 7.6 degrees of the dark limb of the Earth; or
- within 9 degrees of the Moon.

Some rare exceptions have been made to these rules. For example, the moon has been observed, and observations have been made of Venus and a comet despite the sun angle being slightly less than 50 degrees. Significant work is required to support these observations, so very compelling scientific justification is necessary for approval. Observations of the Moon, in particular, have required so much distortion of normal operating procedures that success rates have been low.

2.5 Orientation and Roll Constraints

The orientation (ORIENT) of the telescope is defined as the position angle of the U3 axis on the sky measured from North through East (see Figure 2.2).

In principle, HST is free to roll about the U1 optical axis. However, this freedom is limited by the need to keep sunlight shining on the solar arrays and by a thermal design that assumes that the Sun always heats the same side of the telescope.

For a particular pointing, the orientation of the telescope that optimizes the solar-array positioning with respect to the Sun is called the **nominal roll**. At this orientation the Sun is in the half-plane defined by the U1 axis and the negative U3 axis (see Figure 2.1). Consequently, the nominal roll required for a particular observation depends on the location of the target and the date of the observation. Observations of the same target made at different times will, in general, be made at different orientations. Some departures from nominal roll are permitted during HST observing (e.g., if a specific orientation is required on a particular date, or if the same orientation is required for observations made at different times).

Off-nominal roll is defined as the angle about the U1 axis between a given orientation and the nominal roll. Off-nominal rolls are restricted to less than approximately 5 degrees when the U1-to-sun angle is between 50 and 90 degrees, < 30 degrees when the angle is between 90 and 178 degrees, and it is unlimited between 178 and 180 degrees. (Note that in order to achieve an anti-sun pointing of 178-180 degrees the target must lie in or near the plane of the Earth's orbit.)

Observations requiring a certain ORIENT for a target at a particular time may not be feasible because the required off-nominal roll angle may be outside the allowed limits. The STScI Phase II Remote Proposal Submission 2 (RPS2) software, available from the [Phase II Program Preparation Web Page](#), can be used in such cases to assess the feasibility of the observations.

2.6 Data Storage and Transmission

The Observations and Data Management Division constructs the HST observing schedule and sends the actual command loads to the Science Institute Mission Operations Room (SIMOR) at STScI. Communications with the spacecraft are performed via the Tracking and Data Relay Satellite System (TDRSS), which consists of a set of satellites in geosynchronous orbit. The TDRSS network supports many spacecraft in addition to HST. Therefore, the use of the network, either to send commands or return data, must be scheduled. Because of limited onboard command storage capacity and TDRSS availability, command sequences for HST observations are normally uplinked approximately once every 8 hours. HST then executes the observations automatically.

2.6.1 Real-time Contact Requests

Observers at STScI can interact in real-time with HST for specific purposes (e.g., certain target acquisitions). However, real-time interactions are difficult to schedule and are generally used in exceptional circumstances only. In the past three cycles of HST usage there have been no real-time contacts.

2.6.2 Onboard Data Storage

HST currently uses a large capacity Solid State Recorder (SSR) to store science data before transmission to the ground. Except when real-time access is required, most HST observations are stored to the SSR and read back to the ground several hours later. Some science programs requiring very high data-acquisition rates cannot be accommodated, because the SIs would generate more data than either the links or ground system could handle (see Section 6.2.3).

Telescope Performance

In this chapter . . .

3.1 Optical Performance / 19

3.2 HST Guiding Performance / 20

3.3 HST Observing Efficiency / 21

3.1 Optical Performance

Because the primary mirror has about one-half wave of spherical aberration, the Optical Telescope Assembly (OTA) did not achieve its design performance until after the first servicing mission in December 1993 when corrective optics were installed for the SIs. From this time on, the detectors of all SIs (with the exception of the FGSs) have viewed a corrected beam, either via external corrective optics (COSTAR) or via internal optics (for the second and third-generation instruments). Table 3.1 gives a summary of general OTA characteristics.

Table 3.1: HST Optical Characteristics and Performance

Design	Ritchey-Chretien Cassegrain
Aperture	2.4 m
Wavelength Coverage	From 1100 Å (MgF ₂ limited) To ~3 microns (self-emission limited)
Focal Ratio	$f/24$
Plate Scale (on axis)	3.58 arcsec/mm
PSF FWHM at 5000 Å	0.043 arcsec
Encircled Energy within 0.1" at 5000 Å	87% (60%-80% at the detectors)

Because each SI has unique characteristics, the actual encircled energy is instrument dependent, and may also vary with observing techniques. For instrument specific Point Spread Function (PSF) characteristics over various wavelength ranges, please consult the [Instrument Handbooks](#) (see Section 1.2). The TinyTim software, developed at STScI and the ST-ECF, is available on the [TinyTim Web Page](#) for detailed HST/PSF simulations, which agree well with actual observations.

3.2 HST Guiding Performance

HST's Pointing Control System (PCS) has two guiding modes available. The default guide mode uses Fine Guidance Sensors (FGSs) to provide high precision pointing control by using guide stars to actively control the telescope pointing. However, the telescope pointing can also be controlled using only the rate-sensing gyroscopes.

3.2.1 FGS - Dual Guide Star Acquisitions

The default operational practice is to schedule observations using Dual Guide Star mode. In a Dual Guide Star Acquisition, two FGSs lock onto separate guide stars. The combined pointing information is used to control the pitch, yaw and roll axes of the telescope (by contrast to ground-based telescopes, which generally only use one guide star). Dual Guide Star Acquisition times are typically 6 minutes. Reacquisitions following interruptions due to Earth occultations take about 5 minutes. This pointing control method was designed to keep telescope jitter below 0.007" rms, which is now routinely achieved. A drift of up to 0.05" may occur over a timescale of 12 hours and is attributed to thermal effects as the spacecraft and FGSs are heated or cooled (as a result, observers planning extended observations in 0.1" or smaller STIS slits should execute a target peakup maneuver every 4 orbits; see Section 6.4.2).

3.2.2 FGS - Single Guide Star Acquisitions

In cases where two suitable guide stars are not available, a single guide star acquisition can be used. The translational motion of the HST is then controlled by a guide star in one of the FGSs, while the roll motion is controlled by the gyros. Therefore, a gyro drift will be present that is approximately 1.5 mas/sec *around* the guide star. This introduces a translational drift across the target, the exact size of which depends on the roll drift rate and distance from the single guide star to the instrument aperture (target) in the field-of-view (see Figure 2.2). Note however that the

gyro drift can build up through occultations and typically limits a visit duration to a few orbits.

There are also occasions when a dual guide star acquisition was planned, but one of the planned pair of guide stars cannot be acquired. In this case, the Pointing Control System (PCS) will usually carry out the observations using single FGS guiding.

3.2.3 Gyro-only Pointing Control

It is possible, but not common, to take observations without any guide stars, using only gyro pointing control (e.g., for extremely short exposures, or snapshots). The absolute pointing accuracy using gyros is about 14" (one sigma). The pointing drifts at a typical rate of 1.4 +/- 0.7 mas/sec, but it can be somewhat larger depending on the slew history of HST. Note again that gyro drift can build up through occultations and typically limits a visit duration to 1-2 orbits. This technique has been used to prevent overlight conditions in the FGSs (such as during lunar observations), or to reduce overheads.

3.3 HST Observing Efficiency

HST's "observing efficiency" is defined as the fraction of the total time that is devoted to acquiring guide stars, acquiring astronomical targets, and exposing on them. The main factors that limit the observing efficiency are:

- The low spacecraft orbit, resulting in frequent Earth occultation of most targets.
- Interruptions by passages through the South Atlantic Anomaly.
- The number of user constrained visits.
- The relatively slow slew rate.

In recent cycles, the observing efficiency has been around 50%. Of the usable spacecraft time, about 80% is allocated to science observations, with the remainder devoted to calibration and engineering observations (10%), DD programs and repeats of failed observations (also 10%).



CHAPTER 4:

Cycle 12 Scientific Instruments

In this chapter . . .

4.1 Overview / 24
4.2 Advanced Camera for Surveys (ACS) / 31
4.3 Fine Guidance Sensor (FGS1R) / 32
4.4 Near Infrared Camera and Multi-Object Spectrometer (NICMOS) / 32
4.5 Space Telescope Imaging Spectrograph (STIS) / 34
4.6 Wide Field and Planetary Camera 2 (WFPC2) / 35

This chapter provides a basic description of the SIs that will be offered for use in Cycle 12, as well as a brief overview of the new instruments (Cosmic Origins Spectrograph and Wide Field Camera 3) planned for Cycle 13. For detailed information on all the SIs, please refer to the Instrument Handbooks available from the [Scientific Instruments Web Page](#). Appendix B gives brief descriptions of previous HST instruments, which may be of interest for Archival Research.

4.1 Overview

Table 4.1 - 4.5 summarize the capabilities of the SIs. For some applications more than one instrument can accomplish a given task, but not necessarily with equal quality or speed. Note that there may be small differences between the numbers quoted here and those quoted in the Instrument Handbooks. In such cases the Handbook numbers take precedence.

Table 4.1: HST Instrument Capabilities: Direct Imaging¹

SI	Field of View [arcsec]	Projected Pixel Spacing on Sky [arcsec]	Wavelength Range [Å]	Magnitude Limit ²
ACS/WFC ³	202 x 202	~0.05	3700–11,000	29.1
ACS/HRC	29 x 26	~0.027	2000–11,000	28.8
ACS/SBC	35 x 31	~0.032	1150–1700	25.5
NICMOS/NIC1	11 x 11	0.043	8000–19,000	23.2
NICMOS/NIC2	19 x 19	0.076	8000–25,000	24.7
NICMOS/NIC3	51 x 51	0.20	8000–25,000	25.6
STIS/CCD	52 x 52	0.05	2500–11,000	28.0
STIS/NUV	25 x 25	0.024	1650–3100	24.6
STIS/FUV	25 x 25	0.024	1150–1700	24.0
WFPC2 ⁴	150 x 150	0.10	1200–11,000	27.5
	35 x 35	0.0455	1200–11,000	27.8

Table 4.2: HST Instrument Capabilities: Slit Spectroscopy

SI	Projected Aperture Size	Resolving Power ⁵	Wavelength Range [Å]	Magnitude Limit ²
STIS ⁶	52" x (0.05-2)" [optical]	First order:		
	(25-28)" x (0.05-2)"	~8000	1150–10,300	14.9, 15.4, 20.1
	[UV first order]	~700	1150–10,300	16.6, 19.2, 21.9
	(0.1-0.2)" x (0.025-0.2)"	Echelles:		
	[UV echelle]	~100,000	1150–3100	10.9, 12.4
		~30,000	1150–3100	11.6, 14.3
	25" x (0.05-2)"	Prism:		
	[NUV prism]	~150	1150–3100	19.8

Table 4.3: HST Instrument Capabilities: Slitless Spectroscopy

SI	Field of View [arcsec]	Projected Pixel Spacing on Sky [arcsec]	Resolving Power	Wavelength Range [Å]	Magnitude Limit ²
ACS/WFC grism G800L	202 x 202	~0.05	~100	5500–11000	24.9
ACS/HRC grism G800L	29 x 26	~0.029	~140	5500–11000	24.1
ACS/HRC prism PR200L	29 x 26	~0.027	~100	2000–4000	23.8
ACS/SBC prism PR130L	35 x 31	~0.035	~100	1250–1800	20.7
ACS/SBC prism PR110L	35 x 31	~0.035	~100	1150–1800	19.7
NICMOS ⁷	51 x 51	0.2	200	8000–25,000	21.6,21.1,18.0
STIS ⁸	52 x 52 25 x 25	0.05 0.024	~700–8000 ~150–8000	2000–10,300 1150–3100	See slit spectroscopy above
WFPC2 ⁸	10 x 10	0.1	~100	3700–9800	25

Table 4.4: HST Instrument Capabilities: Positional Astrometry

SI	Field of View	Precision (per observation)	Wavelength Range (Å)	Magnitude
FGS1R	69 square arcmin	1 mas 2 mas	4700–7100	<14.5 <17.0

Table 4.5: HST Instrument Capabilities: Binary Star Resolution and Measurements

SI	Field of View	Minimum Separation [mas]	Accuracy [mas]	Delta Magnitude (max)	Primary Star Magnitude
FGS1R	aperture center 5" x 5" IFOV	8	1	0.6	<14.5
		10	1	1.0	<14.5
		15	1	1.0	<16.6
		20	1	2.5	<16.3
		30	1	4.0	<15.0

Notes to Tables 4.1 - 4.5

¹ WFPC2, ACS, and NICMOS have polarimetric imaging capabilities. STIS, ACS, and NICMOS have coronagraphic capabilities.

² Limiting V magnitude for an unreddened A0 V star in order to achieve a signal-to-noise ratio of 5 in a CR-SPLIT (when appropriate) exposure time of 1 hour assuming low-background conditions (**LOW**; see Section 5.5.1). The limiting magnitude for imaging in the visual is strongly affected by the sky background; under normal observing conditions, the limiting magnitude can be about 0.5 brighter than listed here. Please note that low-sky conditions limit flexibility in scheduling and are not compatible with observing in the CVZ. Single entries refer to wavelengths near the center of the indicated wavelength range. STIS direct imaging entries assume use of a clear filter for the CCD and the quartz filter for the UV (for sky suppression). For STIS spectroscopy to achieve the specified signal-to-noise ratio per wavelength pixel with a 0.5" slit (0.2" for the echelles), multiple values are given corresponding to 1300, 2800 and 6000 Å, respectively (if in range). The ACS/WFC, ACS/HRC and WFPC2 entries in Table 4.1 assume filter F606W. ACS spectroscopy assumes wavelengths of 1300Å (PR130L), 3000Å (PR200L), and 6800Å (G800L). The WFPC2 Charge Transfer Efficiency (CTE) losses are negligible for this filter, due to the significant sky background accumulated over 3600 sec in F606W. However, note that WFPC2 images of faint point sources with little sky background can experience significant CTE losses; please see the [WFPC2 Instrument Handbook](#) for details. The ACS/SBC entry in Table 4.1 assumes filter F125LP. For NICMOS imaging, we assume filter F160W with a detector temperature of 77.1 K; the limiting H magnitude, in the Vega system, is given for a point source to reach S/N=5 in the brightest pixel and 1 hr exposure. Please see the [NICMOS Instrument Handbook](#), Chapter 9, for details.

³ With ramp filters, the FOV is smaller for the ACS/WFC. Please see the [ACS Instrument Handbook](#) for details.

⁴ The WFPC2 has four CCD chips that are exposed simultaneously. Three are "wide-field" chips, each covering a 75" x 75" field and arranged in an "L" shape, and the fourth is a "planetary" chip covering a 35" x 35" field.

⁵ The resolving power is $\lambda/\Delta\lambda$; for STIS it is $\lambda/2\Delta\lambda$ where $\Delta\lambda$ is the dispersion scale in Angstroms/pixel.

⁶ The 25" or 28" first order slits are for the MAMA detectors, the 52" slit is for the CCD. The R ~150 entry for the prism on the NUV-MAMA is given for 2300 Å. More accurate and up to date values for spectroscopic limiting magnitudes can be found in the [STIS Instrument Handbook](#).

⁷ NICMOS has three gratings (G096,G141,G206) for use in NIC3. We assume a detector temperature of 77.1 K and "average" zodiacal light; the limiting Vega system H magnitude for spectroscopy is given for a point source to reach S/N=5 in 1 hr exposure.

⁸ All STIS modes can be operated in a slitless manner by replacing the slit by a clear aperture or filter. WFPC2 has a capability of obtaining low-resolution spectra by placing a target successively at various locations in the WFPC2 linear ramp filter. STIS also has a prism for use in the UV.

4.1.1 Instrument Comparison

Observers often face the choice of deciding which HST instrument is best-suited for a particular observation. In some cases, the choice is limited to one instrument, but in many situations the proposer must decide from among several possibilities. Instrument choices for imaging observations currently include ACS, NICMOS, STIS and WFPC2; WFC3 will replace WFPC2 in 2004. Spectroscopic observations are currently limited to STIS but will be expanded to include COS after the next servicing mission. Some general considerations follow, and further details can be found in the individual instrument handbooks.

- The ACS/WFC camera has a larger field of view than WFPC2, significantly higher throughput over a wide spectral range, lower read-out noise, better sampling of the PSF and a factor of 15 increase in dynamic range. ACS/WFC is not designed for near-UV imaging, a capability which will be offered by WFC3/UVIS. Observers wishing to make near-UV imaging observations should trade the high throughput and angular resolution against the wider field offered by WFPC2. ACS is also a new instrument and is not yet exhibiting significant charge transfer efficiency degradation, due to radiation damage.
- The ACS/HRC provides critical sampling of the PSF in the visible and high throughput in the blue. For broad-band UV imaging it can be competitive with or better than the STIS NUV-MAMA. The WFC3/UVIS channel will also be competitive with the STIS NUV-MAMA and will offer a wider field of view. WFC3/UVIS will have a short wavelength limit of $\sim 2000\text{\AA}$.
- ACS offers a fully apodized Visible/NUV coronagraphic imaging mode with 1.8" and 3.0" occulting spots. It also offers occulted (un-apodized) imaging. STIS offers occulted imaging with partial apodization, but smaller width occulting wedges.
- The ACS/SBC channel provides FUV ($\lambda < 2000\text{\AA}$) imaging capability with greater sensitivity and an extended set of filters compared to the STIS FUV-MAMA. MAMA snapshots will only be available with the STIS MAMA.
- NICMOS is the camera of choice of observations at wavelengths longer than about 1 micron. There is some overlap with ACS at shorter wavelengths. In future cycles the WFC3/IR channel will have higher throughput and a larger FOV than NICMOS, but will have a long wavelength cutoff of 1.7 microns. NICMOS sensitivity extends to 2.5 microns.

- NICMOS has a few other features that will not be superseded by WFC3/IR. NICMOS provides higher spatial resolution (particularly in camera 1), and has facilities for coronagraphic and polarimetric measurements.
- From 3200Å to 10,000Å, STIS is the only instrument allowing $R > 500$ spectroscopy. ACS does offer high throughput grism ($R \sim 100$) imaging in the WFC and prism ($R \sim 100$) imaging in the ACS/HRC.
- In the FUV ($< 1800\text{Å}$), COS should be significantly more sensitive than STIS. From 1800Å to $\sim 2500\text{Å}$, the choice between COS and STIS will depend on details of the observing program. Beyond $\sim 2500\text{Å}$, STIS CCD spectroscopy should be more sensitive than COS. Throughout the UV, STIS will remain the only choice for high spectral resolution ($R \sim 100,000$) or spectroscopy of resolved structure on scales smaller than 1 arcsec. ACS offers high throughput prism ($R \sim 100$) imaging in the ACS/HRC and ACS/SBC channels.

The following tables provide some basic recommendations that may be of use in deciding which HST instrument in Cycle 12. Table 4.6 summarizes typical decisions that are frequently made when choosing an HST instrument for spectroscopic observations. Table 4.7 lists typical decisions that are often made for imaging observations. All recommendations should be considered general in nature and are meant to provide high-level guidance to observers. The ultimate choice of instrument for a particular observation may depend upon a variety of competing factors and is left as a decision to be made by the proposer.

Table 4.6: Spectroscopy Decisions

Type of Observation	Recommended Instrument	Comment
Spectroscopy at $R > 100$	STIS	
slitless spectroscopy	ACS ($R \sim 100$) or STIS ($R > 100$)	

Table 4.7: Imaging Decisions

Type of Observation	Recommended Instrument	Comment
Ultraviolet Observations		
$\lambda < 2000\text{\AA}$	ACS/SBC	Larger FOV, better sensitivity than STIS
$\lambda > 2000\text{\AA}$	WFPC2 or ACS/HRC or STIS/NUV	WFPC2 has the largest FOV ACS/HRC has the highest throughput STIS/NUV has no readout noise
Optical Observations		
Broadband $\lambda > 4000\text{\AA}$	ACS/WFC	Wide field, high throughput
Narrowband $\lambda > 4000\text{\AA}$	WFPC2 or ACS	WFPC2 has more filter choices ACS has a few narrow filters ramp filters are available for smaller areas (both instruments)
High resolution	ACS/HRC	Best sampled PSF
Coronagraphy	ACS/HRC	
Infrared Observations		
Wavelength > 1 microns	NICMOS	Only instrument available

4.1.2 Future Instruments

Two new science instruments, the Cosmic Origins Spectrograph (COS) and the Wide Field Camera 3 (WFC3), will be installed in HST during SM4. Instrument capabilities are outlined in the COS and WFC3 mini-handbooks released with the Cycle 12 Call for Proposals. Highlights of these instruments are described below

The Cosmic Origins Spectrograph (COS) is designed to perform high sensitivity, moderate-resolution ($R \sim 16,000$ - $24,000$) and low-resolution ($R \sim 2000$ - 3000) spectroscopy of astronomical objects in the 1150 - 3200\AA spectral region. COS will significantly enhance the spectroscopic capabilities of HST at ultraviolet wavelengths, and will provide observers with unparalleled opportunities for observing faint sources of ultraviolet light. Wavelength coverage at far-UV wavelengths (1150 - 2050\AA) is expected to be ~ 300 to 820\AA per exposure, depending upon the spectroscopic mode chosen. Far-UV light is recorded by a crossed delay-line microchannel plate (MCP) detector. Wavelength coverage at

near-UV wavelengths (1700-3200Å) is expected to be ~100 to 800Å per exposure, depending upon the spectroscopic mode chosen. Near-UV light is recorded by a multi-anode microchannel array (MAMA) detector similar to the MAMA detectors used on STIS. COS has two circular science apertures that are 2.5 arcseconds in diameter. Limited COS imaging capabilities are available only at near-UV wavelengths. COS is not meant to be a replacement for STIS, which will remain in HST after the servicing mission and will be available to the community. Rather, COS will complement and extend existing HST spectroscopic capabilities. The high sensitivity ultraviolet spectroscopy enabled by COS will allow users to investigate fundamental astrophysical topics such as the ionization and baryonic content of the intergalactic medium, the origin of large scale structure in the Universe, the chemical and dynamical evolution of galaxies, and the properties of stars and planetary systems.

The Wide Field Camera 3 (WFC3) is a panchromatic, wide-field, high-throughput imaging camera that will replace WFPC2 in its radial bay during SM4. It features two independent channels - the UVIS channel, sensitive at ultraviolet and optical wavelengths (2000-10,000Å) with a FOV of 2.7 x 2.7 arcmin and a scale of 0.04 arcsec/pixel, and the IR channel, sensitive at near infrared wavelengths (8500Å - 1.7 microns) with a FOV of 2.2 x 2.2 arcmin and a scale of 0.13 arcsec/pixel. The instrument's extended wavelength range, angular resolution, and large field-of-view, along with high sensitivity and a wide selection of spectral elements (62 filters and 1 grism in the UVIS channel; 14 filters and 2 grisms in the IR channel), provides users with a vast array of options for imaging and low-dispersion, slitless spectroscopy, making WFC3 one of the most versatile instruments onboard HST.

WFC3 complements and extends the capabilities of ACS and NICMOS, and it also provides a high degree of redundancy with these instruments to help secure HST's unique imaging capabilities until the end of its mission. WFC3 is a facility instrument that will allow users to carry out a variety of key scientific investigations, including searches for galaxies at redshift up to $z \sim 10$, the study of the physics of star formation in distant and nearby galaxies, accurate measures of the baryonic mass by detecting stars at the limit of the hydrogen-burning sequence and extra-solar Jupiter-like planets, and study of planetary objects in the Solar System.

4.2 Advanced Camera for Surveys (ACS)

The ACS is designed to advance the survey capabilities of HST, defined as the product (Throughput x DETECTOR AREA), by a factor of ~ 10 in the visual and near infrared. This instrument comprises three channels, each optimized for a specific goal:

- The **Wide Field Channel** (ACS/WFC):

The WFC has a 202×202 arcsec field of view from 3700–11,000 Å, and a peak efficiency of 48% (including the OTA). The plate scale is ~ 0.05 arcsec/pixel, providing critical sampling at 11,600 Å. The detector consists of a mosaic of two 2048×4096 Scientific Imaging Technologies (SITE) CCDs, with 15×15 μm pixels.

- The **High Resolution Channel** (ACS/HRC):

The HRC has a 29×26 arcsec field of view from 2000–11,000 Å and a peak efficiency of 31%. The plate scale is ~ 0.027 arcsec/pixel, providing critical sampling at 6300 Å. The detector is a 1024×1024 Scientific Image Technologies (SITE) CCD, with 21×21 μm pixels.

- The **Solar Blind Channel** (ACS/SBC):

The SBC has a 35×31 arcsec field of view from 1150–1700 Å, and a peak efficiency of 6%. The plate scale is ~ 0.032 arcsec/pixel. The detector is a solar-blind CsI MAMA, with 25×25 μm pixels.

In addition to these three prime capabilities, ACS also provides:

- Grism spectroscopy: Low resolution ($R \sim 100$) wide field spectroscopy from 5500–11,000 Å in both the WFC and the HRC.
- Objective prism spectroscopy: Low resolution ($R \sim 100$ at 2000 Å) near-UV spectroscopy from 2000–4000 Å in the HRC.
- Objective prism spectroscopy: Low resolution ($R \sim 100$ at 1216 Å) far-UV spectroscopy from 1150–1700 Å in the SBC.
- Coronagraphy: Aberrated beam coronagraphy in the HRC from 2000–11,000 Å with 1.8 arcsec and 3.0 arcsec diameter occulting spots.
- Imaging Polarimetry: Polarimetric imaging in the HRC and WFC with polarization angles of 0° , 60° and 120° .

4.3 Fine Guidance Sensor (FGS1R)

As a scientific instrument, the FGS1R offers accurate relative astrometry and high spatial resolution.

In Position (**POS**) mode it measures the relative positions of objects in its 69 square arc minute FOV with a per observation precision of about 1 mas. Position mode observing is used to determine the relative parallax, proper motion and reflex motion of single stars and binary systems. Multi-epoch programs have resulted in measurements accurate to about 0.5 mas or less.

In Transfer (**TRANS**) mode the FGS 5" x 5" instantaneous field of view (IFOV) is scanned across an object to obtain an interferogram with high spatial resolution (conceptually equivalent to an imaging device that samples an object's point spread function with 1 mas pixels).

Transfer mode observing is used to measure the angular size of extended objects or to resolve binary systems and measure the separation, position angle and relative brightness of its components. FGS1R can resolve close binary systems with angular separations of only 8 mas and magnitude differences of less than 1.0. Systems with magnitude differences as large as 4 can be resolved provided the separation of the stars is larger than about 30 mas.

In either mode the FGS yields 40 Hz photometry with a relative precision of about 1 milli-magnitude. Objects over a dynamic range of $3 < V < 17$ can be observed.

4.4 Near Infrared Camera and Multi-Object Spectrometer (NICMOS)

NICMOS provides HST's only infrared capability. The three 256 x 256 pixel cameras of NICMOS are designed to provide, respectively:

- diffraction limited sampling to 1.0 micron (Camera 1);
- diffraction limited sampling to 1.75 micron (Camera 2);
- a relatively large field of view of 51 x 51 arcsec (Camera 3).

Each NICMOS camera provides 19 independent optical elements, offering a wide range of filter options. Cameras 1 and 2 have polarimetric filters; Camera 2 has a 0.3 arcsec radius coronagraphic hole and an optimized cold

mask to support coronagraphic observations; and Camera 3 has three separate gratings providing slitless spectroscopy over the full NICMOS wavelength range. The short wavelength response cutoff at 0.8 micron (see Section 4.1) is a limitation of the HgCdTe detector material, while the long cutoff at 2.5 micron was selected as the longest scientifically useful wavelength given HST's warm optics.

The original coolant of the NICMOS dewar (solid nitrogen) was exhausted in January 1999. The successful installation of the NICMOS Cooling System (NCS) during servicing mission SM3B in March 2002 has fully restored NICMOS functionality, albeit at a higher operating temperature (~77.1K, about 15K higher than with solid nitrogen). Following its on-orbit installation, a series of tests to determine the stability and repeatability of the NCS control law verified that - barring any unforeseen performance degradation - the NCS is capable of maintaining the NICMOS detectors to within 0.1 K of their target temperature under all orbital and seasonal conditions. Because the NICMOS detectors react sensitively to temperature variations, this is extremely positive news for the scientific performance of NICMOS. At their new operating temperature, NICMOS detector characteristics such as quantum efficiency and dark current are different compared to Cycle 7/7N. The performance changes have been measured during the SM3B Orbital Verification program, and are reflected in the current NICMOS Exposure Time Calculator. The bottom line is that for most science programs, the renewed NICMOS is slightly more sensitive than during its earlier life, because of higher DQE and the absence of any anomalously high dark current levels.

4.4.1 Camera Focusing

The NICMOS cameras were designed to be operated independently and simultaneously. However, due to an anomaly in the NICMOS dewar, the three cameras are no longer confocal. While Cameras 1 and 2 are close to being confocal, the use of Camera 3 requires repositioning of the Pupil Alignment Mechanism (PAM). The PAM will be automatically moved to the optimal position whenever Camera 3 is the prime instrument (causing Cameras 1 and 2 to be out of focus).

4.4.2 Dark Levels

During the warmup of the NICMOS instrument following cryogen exhaustion, an anomalous increase (the "bump") in the dark current of all three detectors was observed. The elevated dark current could have compromised NICMOS sensitivity, and hence the question of whether or not the bump would be present after the cooldown was an important one.

The NICMOS calibration program following the cooldown has shown that **the dark current levels of all three NICMOS cameras are nominal**. Therefore, the "bump" option in the NICMOS ETC has been removed.

4.4.3 South Atlantic Anomaly (SAA) Cosmic Ray Persistence

NICMOS data obtained within ~40 minutes of passage through the SAA (see Section 2.3.2) exhibited a persistent signal that significantly degraded the quality of the data. This signal, caused by persistence of the cosmic ray hits, was similar to a slowly decaying, highly structured dark current and could not be removed by the standard calibration pipeline processing.

Because HST passes through the SAA several times a day, a large fraction of NICMOS images are affected by cosmic ray persistence. Beginning in Cycle 12, STScI automatically schedules a pair of NICMOS ACCUM mode dark exposures after each SAA passage. This data will provide a map of the persistent cosmic ray afterglow when it is strongest. Analysis has shown that it is possible to scale and subtract such "post-SAA darks" from subsequent science exposures taken later in the same orbit, which significantly improves the quality of the science data. STScI is currently investigating the possibility of including this part of the processing in the calibration pipeline.

4.5 Space Telescope Imaging Spectrograph (STIS)

STIS uses two-dimensional detectors operating from the ultraviolet to the near infrared (1150–11,000 Å) in support of a broad range of spectroscopic capabilities. STIS can be used to obtain spatially resolved, long-slit (or slitless) spectroscopy of the 1150–10,300 Å range at low to medium spectral resolutions ($R \sim 500$ to 17,000) with first-order gratings. Echelle spectroscopy at medium and high ($R \sim 30,000$ and 110,000) resolutions covering broad spectral ranges of $\Delta\lambda \sim 800$ or 200 Å, respectively, is available in the ultraviolet (1150–3100 Å). STIS can also be used for deep optical and solar-blind ultraviolet imaging.

The three 1024 x 1024 pixel detectors supporting spectroscopy and imaging applications are as follows.

- A solar-blind CsI (FUV) Multi-Anode Microchannel Array (MAMA) with a plate scale of 0.024"/pixel and a 25" x 25" FOV is available from 1150 to 1700 Å.

- A Cs₂Te (NUV) MAMA with a plate scale of 0.024"/pixel and a 25" x 25" FOV is available from 1600 to 3100 Å.
- A CCD with a plate scale of 0.05"/pixel and a 52" x 52" FOV is available from ~2000 to 11,000 Å.

The MAMA detectors support time resolutions down to 125 micro-sec in TIME-TAG mode, and the CCD can be cycled in ~20 sec with use of small subarrays. The CCD and the MAMAs also provide coronagraphic spectroscopy in the visible and ultraviolet. Coronagraphic CCD imaging is also supported.

4.6 Wide Field and Planetary Camera 2 (WFPC2)

The WFPC2 has three “wide-field” CCDs, and one high-resolution (or “planetary”) CCD. Each CCD covers 800 x 800 pixels and is sensitive from 1200 to 11,000 Å. All four CCDs are exposed simultaneously, with the target of interest being placed as desired within the FOV.

The three Wide Field Camera (WFC) CCDs are arranged in an “L”-shaped FOV whose long side projects to 2.5', with a projected pixel size of 0.10". The Planetary Camera (PC) CCD has a FOV of 35" x 35", and a projected pixel size of 0.0455". The WFC configuration provides the larger FOV, but undersamples the cores of stellar images; the PC configuration samples the images better, but has the smaller FOV.

A variety of filters may be inserted into the optical path. Polarimetry may be performed by placing a polarizer into the beam. A ramp filter exists that effectively allows you to image a ~10" region in an arbitrary 1.3% bandpass at any wavelength between 3700 and 9800 Å, by appropriately positioning the target within the FOV.

Observing Considerations

In this chapter . . .

5.1 Bright-Object Constraints / 37
5.2 Target Acquisitions / 38
5.3 Solar-System Targets / 40
5.4 Offsets and Patterns / 41
5.5 Special Background Emission Requirements / 41

5.1 Bright-Object Constraints

Some of the SIs must be protected against over-illumination; observations that violate these protections cannot be executed, and should not be proposed. We emphasize that the constraints discussed below are safety constraints; data become affected by bright objects at substantially fainter limits than the safety limits discussed in the following sections. Bright-object related effects include non-linearity, saturation and residual-image effects. Please consult the [Instrument Handbooks](#) (see Section 1.2) for details.

5.1.1 NICMOS & WFPC2

There are no safety-related brightness limits for NICMOS and WFPC2.

5.1.2 ACS & STIS

The CCDs on ACS and STIS have no safety-related brightness limits.

The MAMA detectors on ACS (SBC) and STIS can be damaged by excessive levels of illumination and are therefore protected by hardware safety mechanisms. In order to avoid triggering these safety mechanisms, STScI will screen all proposals to enforce absolute limits on the brightest targets that can be observed by the MAMAs. Observers must provide accurate information to assist in this screening process.

The MAMA bright object count-rate limits are mode dependent. Specific values are given in the [ACS](#) and [STIS Instrument Handbooks](#), including example magnitude screening limits for astronomical objects observed in the most commonly used modes. In addition, the Exposure Time Calculators (ETCs) accessible from the [Scientific Instruments Web Page](#) can be used to determine if a particular instrument/target combination exceeds the screening limit.

5.1.3 FGS

Objects as bright as $V=3.0$ may be observed if the 5-magnitude neutral-density filter (F5ND) is used. Observations on all objects brighter than $V=8.0$ should be performed with this filter. A hardware limitation prevents the FGS target acquisition from succeeding for any target brighter than $V=8.0$ (3.0 with F5ND).

5.2 Target Acquisitions

Target acquisition is the method used to insure that the target is in the field of view of the requested aperture to the level of accuracy required by the observer. There are several distinct methods of target acquisition; each method has a different approach and different accuracy, and will take different amounts of time and resources to complete. The required level of accuracy depends on the size of the aperture to be used to acquire the science data and on the nature of the science program.

5.2.1 Target Acquisition without the Ground System

Blind acquisition

For blind acquisition, guide stars are acquired and the FGSs are used for pointing control. The pointing is accurate to the guide star position uncertainty, which is approximately 1".

Onboard acquisition

For onboard acquisition, software specific to the scientific instrument centers the fiducial point onto the target. Onboard target acquisitions are needed for all STIS spectroscopic observations (except slitless), and also for coronagraphic observations with ACS, NICMOS and STIS. The WFPC2 does not have onboard acquisition capabilities. For specific information on methods and expected pointing accuracies, see the [Instrument Handbooks](#) (see Section 1.2).

Early acquisition

For early acquisition, an image is taken in an earlier visit to provide improved target coordinates for use with subsequent visits.

5.2.2 Target Acquisition with the Ground System

Target acquisitions that cannot be accomplished reliably or efficiently via one of the above methods may still be possible by transmitting the relevant data to STScI, analyzing them to determine the needed pointing corrections, and then providing those corrections to the telescope. This description covers two kinds of activities, the “real-time target acquisition” and the “reuse target offset”, both of which are described briefly here. You should contact the [STScI Help Desk](#) (see Section 1.3) if either of these capabilities is required.

Real-time target acquisition

This method is available for all scientific instruments except the FGS, but generally used only in exceptional circumstances. High data rate TDRSS links are required at the time the data are read out to transmit the data to the ground, and at a subsequent time to re-point the telescope before the science observations, all of which adds a constraint to the scheduling. The PI, or a designated representative, must be present at STScI at the time of the acquisition. The acquisition data, usually an image, are analyzed by STScI support personnel to compute the image coordinates and the centering slew for the target identified by the PI.

Reuse target offset

An offset slew —derived from an onboard acquisition, or an image done on a previous visit—is used to reduce the amount of time required for acquisitions in subsequent visits to the same target. The data from the initial visit are analyzed by STScI support personnel to provide the offset slew to be repeated for subsequent visits. All subsequent visits to the target must use the same guide stars as the initial visit, which limits the time span of all visits to a few weeks. There are additional instrument-specific requirements.

5.3 Solar-System Targets

Objects within the solar system move with respect to the fixed stars. HST has the capability to point at and track moving targets, including planets, their satellites and surface features on them, with sub-arcsecond accuracy. However, there are a variety of practical limitations on the use of these capabilities that must be considered before addressing the feasibility of any particular investigation.

HST is capable of tracking moving targets with the same precision achieved for fixed targets. This is accomplished by maintaining FGS Fine Lock on guide stars, and driving the FGS star sensors in the appropriate path, thus moving the telescope so as to track the target. Tracking under **FGS control** is technically possible for apparent target motions up to 5 arcsec per second. In practice, however, this technique becomes infeasible for targets moving more than a few tenths of an arcsec per second. An observation can begin under FGS control and then switch over to gyros when the guide stars have moved out of the FGS field of view. If sufficient guide stars are available, it is possible to “hand off” from one pair to another, but this will typically incur an additional pointing error of about 0.3 arcsec.

Targets moving too fast for FGS control, but slower than 7.8 arcsec per second, can be observed under **gyro control**, with a loss in precision that depends on the length of the observation.

The track for a moving target is derived from its orbital elements. Orbital elements for all of the planets and their satellites are available at STScI. For other objects, the PI must provide orbital elements for the target in Phase II. (Note: STScI has the capability to insert an offset to within 3 days of the observation to eliminate “zero-point” errors due to an inaccurate ephemeris.)

5.4 Offsets and Patterns

Offsets (using the same guide stars and performed under the same guide star acquisition) can be performed to an accuracy of about $\pm 0.02''$ for the larger slews. The size of the offset is limited by the requirement that both guide stars remain within the respective FOVs of their FGSs. Offsets within single detectors (most common type) can be performed to within $\pm 0.003''$. Offsets that continue across separate visits (when executed with the same guide stars) will typically have an accuracy of $\sim 0.05''$.

Patterns are used to place the telescope at multiple positions to allow for dithering or mosaic construction. Patterns can define a linear, spiral, or parallelogram series of observation points. Patterns can also be combined to produce a more complex series of observation points. In addition, Convenience Patterns have been predefined to represent typical dither and mosaic strategies; for details see the Phase II Instructions, available from the [Phase II Program Preparation Web Page](#). If guide stars are used, the possible pattern area is limited by the requirement that the same guide stars be used throughout the pattern. This implies about 120 arcsec of maximum linear motion.

5.5 Special Background Emission Requirements

5.5.1 Low-Sky (LOW) Observations

The continuum background for HST observations is a function of when and how a given target is observed. If your observations would be adversely affected by scattered light (e.g., zodiacal light and earthshine), you may request the special **LOW** scheduling requirement. Then your observations will be scheduled such that the sky background is within 30% of its yearly minimum for the given target, which is done by restricting the observations to times that minimize both zodiacal light and earthshine scattered by the OTA. To minimize the zodiacal light, the scheduling algorithm places seasonal restrictions on the observations; to reduce the earthshine, the scheduling system reduces the amount of time data is taken within an orbit by approximately 15% (see Section 6.3). The former complicates scheduling, while the latter reduces the observing efficiency of HST. Therefore, using the **LOW** restriction must have adequate scientific justification included in a Phase I proposal. With this restriction, the zodiacal background light for low-ecliptic latitude targets can be reduced

by as much as a factor of 4. Avoiding the earthshine at the standard earth-limb avoidance angle (see Section 2.4) can make a similar difference.

5.5.2 Shadow (SHD) Observations

A second special scheduling requirement, **SHD**, is available to restrict observing to times when HST is in the Earth shadow. This can be useful for reducing the geocoronal Lyman alpha background. This special requirement complicates scheduling and reduces the HST observing efficiency, and must therefore have adequate scientific justification in a Phase I proposal.

(Note: The **SHD** requirement should *not* be used if low continuum background is required; in that case use **LOW** instead.)

Orbit Calculation for a Phase I Proposal

In this chapter . . .

6.1 Construction of an Observing Program / 43

6.2 HST Visits / 45

6.3 The Visibility Period / 48

6.4 Acquisition Times and Instrument Overheads / 50

6.5 Constructing Your Program / 58

An important issue in the preparation of an HST observing proposal is to calculate the amount of observing time you need to request. This chapter guides you through the steps that are required to accomplish this task.

6.1 Construction of an Observing Program

6.1.1 General Observer (GO) Programs

Definitions (HST Orbits, Visibility Periods and Visits)

HST GO observing time is counted in terms of *orbits*. Each 96 minute orbit of HST contains a certain amount of useful time when the target can be observed, called the *visibility period*. The visibility period depends on the declination of the target and on whether there are any special scheduling constraints. Orbits are grouped into larger units called *visits*; a visit is a series of one or more exposures on a target, including the overheads, that will execute in one or more consecutive orbits.

Components of a Visit

The orbits in a visit generally contain the following components:

- Guide-star acquisition (needed in the first orbit of a visit) or re-acquisition (needed in the subsequent orbits of a visit), to ensure that HST can maintain adequate pointing during each orbit. See Section 3.2 for details on guiding.
- Target acquisition. This is required if the target must be placed in an instrument aperture, e.g., for spectroscopic observations through a slit. Imaging observations (unless coronagraphic) generally do not require a target acquisition. See Section 5.2 for details on target acquisition strategies.
- Science exposures.
- Instrument overheads (e.g., the time required to set up the instrument and read out the data).
- Telescope repositioning overheads for small angle maneuvers.
- Special calibration observations, which may be required if the accuracy provided by the standard calibrations is inadequate for the goals of the project (see [Section 4.3 of the Call for Proposals](#)).

Preparing your Program

To calculate the resources required for your GO program you must take the following steps:

1. Define the observations (instrument setup, number of exposures, exposure times, etc.) you wish to execute on each target. Use the Instrument Handbooks and the Exposure Time Calculator Tools that are available on the [Scientific Instruments Web Page](#) as primary resources in this stage of your proposal preparation.
2. Group your observations into separate visits, following the guidelines in Section 6.2.
3. Determine the visibility period of each target in your proposal (described in Section 6.3).
4. Compute the times required for guide-star acquisitions, target acquisitions, instrument overheads and telescope repositioning overheads (described in Section 6.4).
5. Lay out all the exposure and overhead times for your program into visits (described in Section 6.5) and add up the number of orbits from each visit to obtain your total orbit request.

6.1.2 Snapshot Programs

In a Phase I Snapshot proposal, the PI specifies a requested number of targets, rather than a requested number of orbits. The exposure times and overhead times for Snapshot observations are calculated in similar fashion as for GO observations. The observations for a Snapshot target, including overheads, generally should *not* exceed 45 minutes. See [Section 3.3 of the Call for Proposals](#) for detailed policies and procedures regarding Snapshot observations.

6.2 HST Visits

6.2.1 When is a New Visit Required?

A new visit is required whenever a new set of guide stars must be acquired. This is the case in any of the following situations:

- A change in target position of more than 2 arcmin. Note that Solar-system objects that move more than 2 arcmin during the observations may not necessarily require a new visit (see Section 5.3).
- Repeated, periodic, or other time-separated observations with an interval between exposures that would yield one or more empty visibility periods in the visit (which is not allowed).
- A change in spacecraft roll orientation (e.g., for NICMOS coronagraphic observations, or for STIS long-slit spectra along different position angles on the sky).
- A change in primary instrument (e.g., from WFPC2 to STIS). However, coordinated parallel observations with one or more other SIs in addition to the primary SI do not require a new visit.

6.2.2 Maximum Duration of a Visit

Because of scheduling interactions with the SAA, longer visits are much more difficult to schedule, and they tend to require scheduling in SAA-free orbits (see Section 2.3.2).

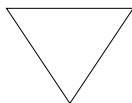

Consequently, any visit that exceeds 5 orbits must be broken into separate, smaller visits.

If you feel that this limit would severely affect the scientific return of your program, then please contact the [STScI Help Desk](#) (see Section 1.3).

Finally, for health and safety reasons, the STIS MAMAs cannot be operated in or around SAA passages, so the five orbit duration limit is strictly enforced on such visits. The ACS/SBC has the same five orbit maximum duration.

6.2.3 Instrument Specific Limitations on Visits

For all SIs except WFPC2, there are SI specific restrictions on the definition of a visit.

ACS: Data Volume Constraints

If ACS data are taken at the highest possible rate (~5 WFC images per orbit) for several consecutive orbits, it is possible to accumulate data faster than it can be transmitted to the ground. High data volume proposals will be reviewed and on some occasions, users may be requested to break the proposal into different visits or consider using sub-arrays. Users can achieve higher frame rates by using subarrays, at the expense of having a smaller field of view; see the [ACS Instrument Handbook](#) for details.

FGS: Astrometry

For astrometric observations using FGS1R, each individual set (consisting of target object and reference objects) may be contained in one visit if there is no telescope motion made during the sequence.

NICMOS: Coronagraphy

We anticipate that most NICMOS coronagraphic observations will be single visits using the full orbit for science observations. Analysis of past NICMOS data has shown that there could be some advantage (i.e., a cleaner PSF subtraction under some circumstances) when obtaining two images of the same target within the same orbit with a roll of the telescope between observations. Executing this roll will require several minutes, including acquisition of new guide stars and the re-acquisition of the target.

Proposals requesting two NICMOS onboard acquisitions (ACQs) in the same orbit will have the following requirements:

- Each ACQ and its corresponding science exposures must be scheduled as a separate visit.
- Each visit must not exceed 22 minutes, including guide star acquisition, ACQ, exposure time and overhead.
- No more than two ACQs within one orbit will be allowed.

The effectiveness of the roll-within-an-orbit technique has been shown to depend heavily on the attitudes of the telescope preceding the coronagraphic observation. Thus, using the technique is not a guarantee of cleaner PSF subtraction.

As an extra insurance policy, observers may want to consider adding an extra orbit for each new pointing. Thermal changes in the telescope are likely to be significantly smaller in the second and subsequent orbits on a target than they are in the first orbit.

NICMOS coronagraphic observations requiring particular telescope orientations (e.g., positioning a companion or disk between diffraction spikes) are time-critical and must be described in the ‘Special Requirements’ section of a Phase I proposal (see [Section 9.3 of the Call for Proposals](#)).

STScI will provide standard calibration reference files, flat fields and darks, which will be available for calibration purposes. Contemporary reference files in support of NICMOS observations are not solicited or normally approved for GO programs, but coronagraphic observers who can justify the need for contemporary calibration observations must include the additional orbit request in the Phase I proposal. Acquisition of bright targets for which an onboard ACQ will not be feasible requires the observer to obtain flat field observations to locate the coronagraphic hole. This implies adding one or more orbits to the total time requested. All calibration data regardless of the program are automatically made public.

STIS: CCD and MAMA Observations in the Same Visit

In general, STIS programs that contain both CCD and MAMA science observations (excluding target acquisitions) must be split into separate CCD and MAMA visits. Exceptions to this rule may be allowed if one of the following two conditions is met:

- There is less than 30 minutes of science observing time (including overheads and target acquisition) using the CCD at a single target position.
- The target is observed for only one orbit.

If you believe your science requires CCD and MAMA science exposures in the same visit (e.g., for variability monitoring programs), you *must* explain this in the Special Requirements section of a Phase I Proposal.

ACS and STIS: Coronagraphy

We anticipate that most ACS and STIS coronagraphic observations will be single visits using the full orbit for science observations. However,

there are some cases where it may be to some advantage in obtaining two images of the same target within the same orbit with a roll of the telescope between the observations. For Cycle 12, we anticipate being able to schedule these types of observations, pending completion of software updates.

Executing this roll will require several minutes, including acquisition of new guide stars and the re-acquisition of the target. Therefore, proposals requesting two ACS or STIS onboard acquisitions (ACQs) in the same orbit will have the following requirements:

- Each ACQ and its corresponding science exposures must be scheduled as a separate visit.
- Each visit must not exceed 22 minutes, including guide star acquisition, ACQ, exposure time and overhead.
- No more than two ACQs within one orbit will be allowed.

ACS and STIS coronagraphic observations requiring particular telescope orientations (e.g. position a companion or disk between diffraction spikes) are time-critical and must be described in the 'Special Requirements' section of a Phase I proposal (see [Section 9.3 of the Call for Proposals](#)).

6.3 The Visibility Period

The *visibility period* is the amount of unocculted time per orbit during which observations of a given target can be made. Table 6.1 gives the visibility period for fixed targets of given declination, for moving targets (assumed to be near the ecliptic plane), and for cases in which the special requirements **LOW** (see Section 5.5.1), **SHD** (see Section 5.5.2), or **CVZ** (see Section 2.3.1) are used.

For **SHD** observations you have only 25 minutes for the observations, regardless of target declination. However, guide-star acquisitions and re-acquisitions, as well as end-of-orbit overheads, may be done outside the narrower shadow time window, depending on the HST ephemeris at the time of execution.

The listed visibility time for the CVZ (96 minutes, i.e., the entire HST orbit) assumes that there are no SAA intersections in these orbits (see Section 2.3.2). This is the visibility time that you should use if you are planning CVZ observations, unless you know that you may have to observe in orbits that are SAA-impacted. In the latter case the visibility time is approximately 70 minutes per orbit. Note that CVZ orbital visibility should

not be requested if there are special background emission (SHD, LOW) or timing requirements (see Section 2.3.1).

Visibility Period for Pure Parallel Observations

If you are proposing for Pure Parallel observations (see [Section 4.2.2 of the Call for Proposals](#)), then you may not know the prime target declinations. You should then use one of the following two options when planning your observations:

- Use the minimum allowed visibility period given your target selection criteria; e.g., if your requirement calls for fields around M31 (at a declination of 41 degrees), then use 54 minutes.
- Map out the exposures (plus overheads) you wish to obtain in an orbit for any legal visibility period (52–60 minutes). If you select this method, note that longer total exposure times typically have fewer opportunities to schedule.

Table 6.1: Orbit Visibility

Target	Declination (degrees)	SHD or CVZ Special Requirement	Regular Visibility [min.]	LOW visibility [min.]
Moving	object near ecliptic plane	no	53	48
Fixed	0–18°	no	52	47
Fixed	18–33°	no	53	48
Fixed	33–43°	no	54	48
Fixed	43–48°	no	55	45
Fixed	48–53°	no	56	45
Fixed	53–58°	no	57	45
Fixed	58–63°	no	56	46
Fixed	63–68°	no	57	45
Fixed	68–73°	no	58	43
Fixed	73–88°	no	59	42
Fixed	88–90°	no	60	41
Any	Any	SHD	25	incompatible
Any	Any CVZ declination	CVZ	96	incompatible

6.4 Acquisition Times and Instrument Overheads

You cannot use the entire target visibility time for actual science exposures, because of the required times for guide-star acquisition, target acquisition and SI overheads. The following subsections discuss the amounts of time that should be budgeted for these items; they are conservative approximations suitable for use in a Phase I proposal and may differ slightly from the numbers in the Instrument Handbooks.

6.4.1 Guide Star Acquisition Times

Table 6.2 summarizes the times required for guide-star acquisitions. A normal guide-star acquisition, required in the first orbit of every visit, takes 6 minutes. At the beginning of subsequent orbits in a multi-orbit visit, the required guide-star re-acquisition takes 5 minutes. For CVZ observations guide-star re-acquisitions are not required, but if an observation extends into SAA-impacted orbits (see Section 2.3.2), then guide-star re-acquisitions will be necessary for those orbits. If gyro-only guiding is used (see Section 3.2.3), then there is no overhead for guide-star acquisition.

Table 6.2: Guide-Star Acquisition Times

Type of Acquisition	Time [min.]	Use
Guide star acquisition	6	First orbit of every visit. Applies also to snapshot observations.
Guide star re-acquisition	5	All orbits of a multi-orbit visit, except the first orbit. May not be needed for CVZ observations (see text).
No guide star acquisition	0	Used for gyro-only guiding (see Section 3.2.3).

6.4.2 Target Acquisition Times

A target acquisition may be required after the guide-star acquisition, depending on the SI used and pointing requirements. See Section 5.2 for a basic overview of target acquisitions. Consult the [Instrument Handbooks](#) (see Section 1.2) to determine whether a target acquisition is required for your particular observations, and which acquisition type is most appropriate. Then use Table 6.3 to determine the time that you need to budget for this.

The most common use of target acquisitions is for STIS **spectroscopy**. Two target acquisition strategies are provided: ACQ and ACQ/PEAK. Consult the [STIS Instrument Handbook](#) for details.

Most **normal imaging** observations with ACS, NICMOS, STIS and WFPC2 do not require a target acquisition (assuming that the coordinates delivered by the observer in Phase II have sufficient accuracy of 1"-2"). However, for **coronagraphic imaging** with ACS/HRC, NICMOS/NIC2 or STIS, you will need to perform a target acquisition to place the target behind the coronagraphic hole or feature. For STIS, the same ACQ and ACQ/PEAK strategies are available as for spectroscopy, while for ACS/HRC and NICMOS/NIC2 modes called ACQ are available. Note that the acquisition algorithms work differently for the different instruments, even if the modes have the same names.

FGS observations use a so-called spiral search location sequence for target acquisitions. This is part of a science observation, and the time required for the acquisition is considered to be part of the overhead associated with the science observation (see Table 6.6).

In exceptional cases you may require a **real-time interaction** with the telescope to perform a target acquisition (see Section 5.2.2). You will then first obtain an image which you should treat as a normal science exposure. Then add 30 minutes for the real-time contact (which may overlap with the occultation interval at the end of an orbit).

Table 6.3: Target Acquisition Times

SI	Type of Acquisition	Time [min.]	Notes
ACS	ACQ	3.5	Used to position a target behind the HRC coronagraphic spot. For faint targets, add 2 times the acquisition exposure time.
NICMOS	ACQ	2.6	Used to position a target behind the NIC2 coronagraphic hole.
STIS	ACQ	6	Used for STIS spectroscopy or coronagraphy. For faint targets ($V > 20$), add 4 times the acquisition exposure time determined by the Target Acquisition ETC.
STIS	ACQ/PEAK	6	Used for STIS spectroscopy or coronagraphic observations that require the highest precision. For faint targets ($V > 20$), add 4 times the acquisition exposure time determined by the Target Acquisition ETC.
Any	Interactive	30	Used for real-time interactions with the telescope in very exceptional circumstances.

Generally, a target acquisition does not need to be repeated for separate orbits of a multi-orbit visit. However, we recommend that observers planning multi-orbit observations in 0.1" or smaller STIS slits insert a target pickup maneuver every 4 orbits (see Section 3.2.1).

A target acquisition, if necessary, usually should be inserted in each visit. However, programs with multiple visits to the same target within a six-week period (start to finish) may be able to use the **reuse target offset** function (see Section 5.2.2). If reuse target offset is appropriate for your program, then you should include the full target acquisition sequence only in the initial visit; the subsequent visits will not need a full target acquisition. However, they will require a SAM (see Section 6.4.4) for the offset maneuver, and they usually require the final pickup stage used in the original acquisition. Please contact the [STSci Help Desk](#) (see Section 1.3) if you feel your program can benefit from this capability.

6.4.3 Instrument Overhead Times

There are a variety of instrument overheads associated with science exposures. Tables 6.4 to 6.13 summarize for each instrument how much time you need to budget for these overheads, depending on the observing strategy.

ACS

ACS overheads are listed in Tables 6.4 and 6.5.

The overhead per exposure is shorter if the exposure is the same as the previous exposure. This means that the exposures use the same aperture and spectral element, but the exposure times need not be the same. If you are unsure whether the shorter overhead time is appropriate, then use the longer overhead time (to avoid a possible orbit allocation shortfall later).

Table 6.4: ACS Exposure Overheads

SI Mode	Time [min.] WFC	Time [min.] HRC	Time [min.] SBC	Notes
IMAGING/ SPECTROSCOPIC	4.0	2.5	1.7	A single exposure or the first exposure in a series of identical exposures.
IMAGING/ SPECTROSCOPIC	2.5	1.0	0.9	Subsequent exposures in an identical series of exposures.
IMAGING/ SPECTROSCOPIC	5.7	0	0	Additional overhead for subsequent exposures (except the last) in an identical series of exposures if the exposure time is less than 6 minutes.
SPECTROSCOPIC	10	8.5	7.7	Automatically executed imaging exposure for prism spectroscopy (provides the image to co-locate the targets and their spectra; see the ACS Instrument Handbook for details).
SPECTROSCOPIC	7	5.5	4.7	Automatically executed imaging exposure for grism spectroscopy (provides the image to co-locate the targets and their spectra; see the ACS Instrument Handbook for details).

Table 6.5: ACS Miscellaneous Overheads

Type	Time [min.]
Overhead for switching from HRC to SBC in an orbit	17.0
Overhead for switching from SBC to HRC in an orbit	14.0

FGS

FGS overheads are listed in Tables 6.6 and 6.7.

The total TRANS mode overhead consists of an acquisition overhead plus an overhead per scan. Hence, the total overhead depends on the number of scans obtained during a target visibility period. In Table 6.8 we list the recommended number of scans as function of target magnitude. The recommended *exposure* time is 40 seconds per scan (excluding overheads).

Table 6.6: FGS Exposure Overheads

SI Mode	Time [min.]	Notes
POS	1	if target magnitude $V < 14$
POS	2	if target magnitude $14 < V < 15$
POS	3	if target magnitude $15 < V < 16$
POS	4	if target magnitude $16 < V < 16.5$
POS	8	if target magnitude $V > 16.5$
TRANS	1	target acquisition (independent of target magnitude)
TRANS	0.2	overhead per scan (independent of target magnitude)

Table 6.7: FGS Miscellaneous Overheads

Type	Time [min.]
Instrument Setup, per orbit	4
Instrument Shutdown, per orbit	3

Table 6.8: Recommended number of FGS TRANS mode scans

V-magnitude	8-12	13-14	15	16
# scans	10	20	30	60

NICMOS

A large number of different overheads exist for NICMOS observations, as listed in Tables 6.9 and 6.10, and discussed in detail (with examples) in Chapter 10 of the NICMOS Instrument Handbook.

The overhead for the MULTIACCUM mode (the readout mode that proposers are encouraged to use whenever possible) is fixed. The overhead on the ACCUM mode is a function of the number of reads, NREAD, obtained at the beginning (and at the end) of an exposure. The range of allowed NREADs is 1 (default) to 25.

Table 6.9: NICMOS Exposure Overheads

SI Mode	Time	Notes
IMAGING/ SPECTROSCOPIC	4 sec	MULTIACCUM exposures.
IMAGING/ SPECTROSCOPIC	7 + (NREAD x 0.6) sec	ACCUM exposures; NREAD=1-25

Table 6.10: NICMOS Miscellaneous Overheads

Type	Time [min.]
Instrument set-up at the beginning of an orbit	0.3
Filter change in the same camera	0.3
Overhead for switching from NIC1 to NIC2, or vice versa, in an orbit	1.4
Overhead for switching from NIC1 to NIC3 or vice versa, in an orbit	9.7
Overhead for switching from NIC2 to NIC3 or vice versa, in an orbit	4.8

STIS

STIS overheads are listed in Table 6.11.

The overhead per exposure is shorter if the exposure is the same as the previous exposure ('no change'); this means that the exposures use the same aperture, grating and central wavelength, but the exposure times need not be the same. If you are unsure whether the shorter overhead time is appropriate, then use the longer overhead time.

Table 6.11: STIS Exposure Overheads

Config/Mode	Time [min.]	Notes
CCD IMAGING/SPECTROSCOPIC	5	Overhead per exposure.
CCD IMAGING/SPECTROSCOPIC	1	Overhead per exposure, if no change from the previous exposure.
MAMA IMAGING (FUV or NUV)	5	Overhead per exposure.
MAMA IMAGING (FUV or NUV)	1	Overhead per exposure, if no change from the previous exposure.
MAMA SPECTROSCOPIC (FUV or NUV)	8	Overhead per exposure.
MAMA SPECTROSCOPIC (FUV or NUV)	1	Overhead per exposure, if no change from the previous exposure.

WFPC2

WFPC2 overheads are listed in Tables 6.12 and 6.13.

Exposures are usually split in two (CR-SPLIT) to allow for cosmic ray rejection (this is the default for exposure times longer than 10 minutes). If an exposure is CR-SPLIT, you should count it as a single exposure with a single (5 minute) overhead. For exposures that are not CR-SPLIT (the default for exposure times equal to or shorter than 10 minutes), use the ‘without CR-SPLIT’ overhead time.

An ‘efficiency’ overhead of 1 minute should be added to each orbit of WFPC2 imaging, which allows for scheduling flexibility during SAA-impacted HST orbits.

Table 6.12: WFPC2 Exposure Overheads

Mode	Time [min.]	Notes
IMAGING	3	Exposure without CR-SPLIT
IMAGING	5	CR-SPLIT exposure (i.e., two separate exposures and readouts)
IMAGING	2	Additional overhead for each exposure with the LRF (required because of telescope repositioning).

Table 6.13: WFPC2 Miscellaneous Overheads

Type	Time [min.]
'Efficiency' overhead, per orbit	1

6.4.4 Telescope Repositioning Overhead Times

Small Angle Maneuvers (SAMs) are changes in telescope pointing of less than 2 arcmin. Table 6.14 lists the overhead times for SAMs.

Table 6.14: Small Angle Manuver Time

Step-size	SAM time
0" < step-size < 1.25"	20 seconds
1.25" < step-size < 10"	30 seconds
10" < step-size < 28"	40 seconds
28" < step-size < 60"	50 seconds
60" < step-size < 2'	65 seconds

A “reuse target offset” visit (see Section 5.2.2 and Section 6.4.2) will require a SAM to be scheduled at the start of the first orbit. To allow for the offset adjustment, the SAM should be assumed to have a duration of 30 seconds.

Patterns (see Section 5.4) perform a series of SAMs. The timing and subsequent overheads depend on the size of the pattern. However, a simple estimate for the overhead time associated with a pattern is obtained by multiplying the number of points minus 1 times the overhead time for a single SAM (see Table 6.14) whose size matches the pattern spacing.

In recent years, many observers have been using *dithering*, or small spatial displacements, to allow for better removal of chip defects and the reconstruction of sub-pixel resolution. Successful proposers will be provided with “canned” dithering routines in Phase II, which avoid some of the tricky details involved in planning patterns. The dithering strategies are implemented as Convenience Patterns and the SAM overheads can thus be estimated as described above. Please consult the [WFPC2](#), [ACS](#), and [STIS Instrument Handbooks](#) for details on the advantages, disadvantages, and overheads associated with dithering.

6.5 Constructing Your Program

Your final step is to fit all science exposures and overheads into the visibility period of each orbit for all your visits. The better you can pack your orbits, the more efficient your proposal will be.

When placing the observations into orbits and visits, note that you cannot pause exposures across orbits. This means that if you have 20 minutes left in an orbit, you can insert only an exposure that takes 20 minutes or less (including overhead). If you wish to obtain a 30 minute exposure, then you can either put it all into the next orbit, or you can specify, for example, a 20 minute exposure at the end of the first orbit, and a second 10 minute exposure in the next orbit.

Table 6.15 shows, as an example, the layout of a visit of 2 orbits for spectroscopic observations that require a target acquisition, but no SAMs and no special calibration observations. For simplicity, overheads are shown to occur after each exposure; in reality some overheads occur before an exposure (e.g., a filter change) while others appear afterwards (e.g., read-out time).

Table 6.15: Example Visit

Orbit 1	Guide Star Acq.	Target Acq.	Over- head.	Science Exp.	Over- head	Earth Occult.
Orbit 2	Guide Star Re-acq.	Science Exp.	Over- head	Science Exp.	Over- head	Earth Occult.

More detailed examples for each of the SIs are listed in Appendix A. Those examples are for common, simple uses of the instruments. For examples of more complicated uses and observing strategies, please consult the [Instrument Handbooks](#) (see Section 1.2).

Coordinated Parallel Observations

If you have a program with coordinated parallel observations (see [Section 4.2.1 of the Call for Proposals](#)), then it should be fairly straightforward to lay out the parallel observations into orbits and visits. The primary observations determine the orbit and visit structure, and the coordinated parallels should conform to the visit structure of the primary observations.

Data Processing and the HST Data Archive

In this chapter . . .

7.1 Routine Science Data Processing / 59

7.2 The HST Data Archive / 60

7.1 Routine Science Data Processing

Science data obtained with HST are sent to the TDRSS satellite system, from there to the TDRSS ground station at White Sands, New Mexico, then to the Sensor Data Processing Facility at Goddard Space Flight Center in Greenbelt, Maryland, and then finally to STScI. At STScI the production pipeline provides standard processing for data editing, calibration and product generation. These functions, performed automatically, include the following:

- Reformatting and editing of data from spacecraft packet format to images and spectra.
- Performing standard calibrations (flat fields, wavelength calibrations, background subtraction, etc.) with currently available calibration files.
- Producing standard data output products (FITS files of raw and calibrated images, OMS [jitter and performance flags] files, and so on).

The standard calibrations performed on HST data, and the resulting output data products, are described in detail in the HST [Data Handbook](#). Note that,

as of the summer of 2000, STScI no longer archives calibrated data; the production pipeline is run on-the-fly, as described in Section 7.2.1.)

7.1.1 Space Telescope Science Data Analysis System (STSDAS)

STScI maintains a set of tools and support software used to calibrate and analyze HST data. The main component of this is the Space Telescope Science Data Analysis System (STSDAS), which is accompanied by TABLES, a set of tools for creating and manipulating tabular data, reading and writing FITS images and tables, and creating customized graphics. STSDAS and TABLES are layered onto the Image Reduction and Analysis Facility (IRAF) software from the National Optical Astronomy Observatories (NOAO). You must be running IRAF in order to run STSDAS and TABLES. STSDAS and TABLES are supported on a variety of platforms, although not all of the platforms that IRAF supports. STSDAS contains, among many other things, the same calibration software that is used by the HST data pipeline. HST observers can therefore recalibrate their data, examine intermediate calibration steps, and re-run the pipeline using different calibration switch settings and reference data. Detailed information on STSDAS and TABLES, including the actual software, is available from the [STSDAS Web Page](#). Information about IRAF is available from the [IRAF Web Page](#).

7.2 The HST Data Archive

All science and calibration data, along with a large fraction of the engineering data, are placed in the HST Data Archive. Science data become immediately available to a program's Principal Investigator and those designated by him/her. These data may be retrieved after the PI has registered as an archive user, and are normally proprietary for a period of one year (see [Section 5.1 of the Call for Proposals](#) for information on data rights).

Typically the science data from HST flow through the production pipeline and into the Data Archive within 2-3 days after execution on the telescope. The observer is notified by e-mail when the first datasets reach the archive, and is provided with web tools to track a visit's completeness as well as to retrieve the data generated by it. The time for retrieving data from the Archive is nominally a few hours, but can be more than a day depending upon the data load and system status. However, occasional software or system failures may lengthen the processing/retrieval times.

If you have strict scientific requirements for data receipt within days after execution, such as to provide pointing corrections for tightly scheduled visits, there are resource-intensive methods to expedite delivery of data. If you have such requirements, they must be stated in your proposal so that the resource needs can be determined and reviewed.

As of July 1, 2002, the HST Archive contained over 474,000 individual observations. These observations, along with engineering and other supporting information, comprise over 8.6 Terabytes of data. About 300 new observations (and 11 Gbytes of data) are archived every day. The heart of the Archive is the Data Archive and Distribution Service (DADS)—a collection of magneto-optical disks on which the data are stored, the databases that comprise the Archive catalog, and the hardware and software that support the ingest and distribution of HST data.

7.2.1 StarView and Web Access to the HST Data Archive

Most of the data in the HST Archive are public and may be retrieved by any user. The Archive can be accessed either through the [MAST Web Page](#) or by using a special user interface called StarView. The Web interface provides a fast way to perform simple searches of the Archive, and to retrieve data and calibration files. StarView is a JAVA-based tool that runs on most operating systems. It provides a wider range of options for searching the Archive, including the ability to create custom queries and to cross-correlate lists of objects observed by HST. Search results from StarView can also be saved to a file. The [Starview Web Page](#) provides information and instructions for downloading the StarView program. Updates on the HST Archive are provided in both StarView and on the MAST website.

The MAST website and StarView allow you to preview most of the publicly available images and spectra. Both interfaces also offer integrated access to the [Digitized Sky Survey \(DSS\)](#) and allow the user to access the [Set of Identifications, Measurements and Bibliography for Astronomical Data \(SIMBAD\)](#) or [NASA/IPAC Extragalactic Database \(NED\)](#) to look up the coordinates of an object by name.

All data requested from WFPC2, ACS, STIS, and NICMOS will be reprocessed in the pipeline at the time of the request. This On-The-Fly Reprocessing (OTFR) takes the science data in spacecraft packet format and generates calibrated files. On-The-Fly Reprocessing replaces On-The-Fly Calibration (OTFC). OTFR differs from OTFC by starting at an earlier stage in the data pipeline, and allows a clean integration of new headers with updated keywords which are fully compatible with the latest version of the pipeline and calibration software. As of the summer of 2000,

the Archive ceased to save the initial versions of the calibrated data for STIS and WFPC2. The first version of the OTFR system provides both raw and calibrated data files for all requests for science data. Future versions will provide options to select the files received.

STScI maintains an “Archive Hotseat” to which all Archive-related questions, problems, or comments should be referred. The Archive Hotseat can be reached by email at archive@stsci.edu or by phone at 410-338-4547.

Orbit Calculation Examples

In this appendix . . .

A.1 ACS / 63
A.2 FGS / 65
A.3 NICMOS / 67
A.4 STIS / 69
A.5 WFPC2 / 70

Chapter 6 described the issues involved in the construction of an observing program, and in the calculation of the total orbit request for a Phase I proposal. As an illustration, this Appendix contains some specific, simple example orbit calculations for each of the SIs offered in Cycle 12.

A.1 ACS

Suppose that you wish to use the ACS to observe a target at a declination of +35 degrees, so that there are 54 minutes of visibility time per orbit (see Table 6.1). Your desired exposures are listed in Table A.1, and the associated overheads are listed in Table A.2. In Table A.3 you can see how the observations fit into a total of 2 orbits.

Table A.1: ACS Example: Planned Exposures

Config	Mode	Spectral Element	Number of Exp	Time per Exp [m]	Notes
ACS/WFC	IMAGING	F606W	4	8.5	Pattern (see Section 5.4) with an offset of 25" between positions
ACS/HRC	IMAGING	F814W	2	6	CR-SPLIT
ACS/HRC	IMAGING	F606W	2	6	CR-SPLIT
ACS/HRC	IMAGING	F435W	2	7	CR-SPLIT

Table A.2: ACS Example: Incurred Overheads

Overhead	Overhead Time [m]	Notes	see Table
Guide star acquisition	6	First orbit in new visit	6.2
Guide star re-acquisition	5	Per orbit after first orbit	6.2
WFC exposure (first)	4	First exposure in a series of identical exposures	6.4
WFC exposure (not first)	2.5	Per exposure after the first exposure in a series	6.4
HRC exposure (first)	2.5	First exposure in a series of identical exposures	6.4
HRC exposure (not first)	1	Per exposure after the first exposure in a series	6.4
SAM of 25"	0.5	Small Angle Maneuver between positions in the pattern	6.14

Table A.3: ACS Example: Orbit Planning

Activity	Duration [m]	Elapsed Time [m]
Orbit 1		
Guide star acquisition	6	6
WFC/F606W Exp Time	4x8.5	40
WFC/F606W Overhead	4+(3x2.5)+(3x0.5)	53
Unused time	1	54
Orbit 2		
Guide star re-acquisition	5	5
HRC/F814W Exp Time	2x6	17
HRC/F814W Overhead	2.5+1	20.5
HRC/F606W Exp Time	2x6	32.5
HRC/F606W Overhead	2.5+1	36
HRC/F435W Exp Time	2x7	50
HRC/F435W Overhead	2.5+1	53.5
Unused time	0.5	54

A.2 FGS

Suppose that you wish to use the FGS to observe a binary star named Binary01, as well as five reference stars ref1,.....,ref5. All stars are in the same FGS field of view, and can therefore be observed in one and the same visit (see Section 6.2.3). Stars ref4 and ref5 have magnitude $V=14.6$, and all the other targets have $13.0 < V < 14.0$. The targets have a declination of +42 degrees, so that there are 54 minutes of visibility time per orbit (see Table 6.1). To enable the removal of drift and jitter in the post observation analysis of the data, the binary is observed in POS mode three times and the reference stars are each observed twice. Your desired exposures are listed in Table A.4, and the associated overheads are listed in Table A.5. In Table A.6 you can see how this fits into a total of 1 orbit.

Table A.4: (Continued)FGS Example: Planned Exposures

Config	Mode	Spectral Element	Number of Exp	Time per Exp [m]	Notes
FGS	POS	F583W	8	0.2	2 exposures of target Binary01, and 2 exposures for each of the targets ref1, ref2 and ref3
FGS	POS	F583W	4	0.7	2 exposures for each of the targets ref4 and ref5
FGS	TRANS	F583W	1	13.3	20 scans of 40 sec each (see Table 6.8) for Binary01

Table A.5: FGS Example: Incurred Overheads

Overhead	Overhead Time [m]	Notes	see Table
Guide star acquisition	6	First orbit in new visit	6.2
POS	1	per exposure, $V < 14$	6.6
POS	2	per exposure, $14 < V < 15$	6.6
TRANS	1	per target	6.6
TRANS	0.2	per scan	6.6
Instrument Setup	4	once every orbit	6.7
Instrument Shutdown	3	once every orbit	6.7

Table A.6: FGS Example: Orbit Planning

Activity	Duration [m]	Elapsed Time [m]
Orbit 1		
Guide star acquisition	6	6
Instrument Setup	4	10
Binary01/POS mode Exp Time	0.2	10.2
Binary01/POS mode Overhead	1	11.2
ref1/POS mode Exp Time	0.2	11.4
ref1/POS mode Overhead	1	12.4
ref2/POS mode Exp Time	0.2	12.6
ref2/POS mode Overhead	1	13.6
ref3/POS mode Exp Time	0.2	13.8
ref3/POS mode Overhead	1	14.8
ref4/POS mode Exp Time	0.7	15.5
ref4/POS mode Overhead	2	17.5
ref5/POS mode Exp Time	0.7	18.2
ref5/POS mode Overhead	2	20.2
Binary01/POS mode Exp Time	0.2	20.4
Binary01/POS mode Overhead	1	21.4
ref1/POS mode Exp Time	0.2	21.6
ref1/POS mode Overhead	1	22.6
ref2/POS mode Exp Time	0.2	22.8
ref2/POS mode Overhead	1	23.8
ref3/POS mode Exp Time	0.2	24.0
ref3/POS mode Overhead	1	25.0
ref4/POS mode Exp Time	0.7	25.7
ref4/POS mode Overhead	2	27.7
ref5/POS mode Exp Time	0.7	28.4
ref5/POS mode Overhead	2	30.4
Binary01/POS mode Exp Time	0.2	30.6
Binary01/POS mode Overhead	1	31.6
Binary01/TRANS mode Exp Time	13.2	44.8
Binary01/TRANS mode Overhead	$1+(20 \times 0.2)$	49.8
Instrument Shutdown	3	52.8
Unused	1.2	54.0

A.3 NICMOS

Suppose that you wish to use the NICMOS to observe a target at a declination of -50 degrees, so that there are 56 minutes of visibility time per orbit (see Table 6.1). Your desired exposures are listed in Table A.7, and the associated overheads are listed in Table A.8. In Table A.9 you can see how the observations fit into a total of 1 orbit.

Table A.7: NICMOS Example: Planned Exposures

Config	Mode	Spectral Element	Number of Exp	Time per Exp [m]	Notes
NIC2	IMAGING	F110W	4	2.1	Pattern (see Section 5.4) of MULTIACCUM exposures with an offset of 1" between dither positions
NIC2	IMAGING	F160W	4	4	Pattern (see Section 5.4) of MULTIACCUM exposures with an offset of 1" between dither positions
NIC2	IMAGING	F222M	4	4	Pattern (see Section 5.4) of MULTIACCUM exposures with an offset of 1" between dither positions

Table A.8: NICMOS Example: Incurred Overheads

Overhead	Overhead Time [m]	Notes	see Table
Guide star acquisition	6	First orbit in new visit	6.2
MULTIACCUM exposure	0.07		6.9
Instrument Setup	0.3	Beginning of each orbit	6.10
Filter change	0.3		6.10
SAM of 1"	0.33	Small Angle Maneuver between positions in the pattern	6.14

Table A.9: NICMOS Example: Orbit Planning

Activity	Duration [m]	Elapsed Time [m]
Orbit 1		
Guide star acquisition	6	6
Instrument Setup	0.3	6.3
F110W Exp Time	2.1	8.4
F160W Exp Time	4	12.4
F222M Exp Time	4	16.4
Overhead	$(3 \times 0.07) + (2 \times 0.3) + (1 \times 0.33)$	17.4
F110W Exp Time	2.1	19.5
F160W Exp Time	4	23.5
F222M Exp Time	4	27.5
Overhead	$(3 \times 0.07) + (3 \times 0.3) + (1 \times 0.33)$	28.9
F110W Exp Time	2.1	31.0
F160W Exp Time	4	35.0
F222M Exp Time	4	39.0
Overhead	$(3 \times 0.07) + (3 \times 0.3) + (1 \times 0.33)$	40.4
F110W Exp Time	2.1	42.5
F160W Exp Time	4	46.5
F222M Exp Time	4	50.5
Overhead	$(3 \times 0.07) + (3 \times 0.3) + (1 \times 0.33)$	51.9
Unused	4.1	56

A.4 STIS

Suppose that you wish to use the STIS to observe a target at a declination of +15 degrees, so that there are 52 minutes of visibility time per orbit (see Table 6.1). Your desired exposures are listed in Table A.10, and the associated overheads are listed in Table A.11. In Table A.12 you can see how this fits into a total of 2 orbits.

Table A.10: STIS Example: Planned Exposures

Config	Mode	Spectral Element	Number of Exp	Time per Exp [m]	Notes
STIS/CCD	ACQ				target acquisition
STIS/CCD	ACQ/PEAK				peakup acquisition (necessary because of use of 0.1" wide slit for subsequent spectra)
STIS/CCD	IMAGING	F28X500II	2	2	
STIS/NUV	IMAGING	F25QTZ	1	19	
STIS/NUV	SPECTROSCOPIC	G230L	1	13	with 52X0.1 slit
STIS/FUV	SPECTROSCOPIC	G140L	1	17	with 52X0.1 slit

Table A.11: STIS Example: Incurred Overheads

Overhead	Overhead Time [m]	Notes	see Table
Guide star acquisition	6	first orbit in new visit	6.2
Guide star re-acquisition	5	per orbit after first orbit	6.2
ACQ	6	target acquisition	6.3
ACQ/PEAK	6	peakup target acquisition	6.3
CCD imaging	5	but only 1m if no change from previous exposure	6.11
MAMA imaging	5	but only 1m if no change from previous exposure	6.11
MAMA spectroscopy	8	but only 1m if no change from previous exposure	6.11

Table A.12: STIS Example: Orbit Planning

Activity	Duration [m]	Elapsed Time [m]
Orbit 1		
Guide star acquisition	6	6
ACQ	6	12
ACQ/PEAK	6	18
F28X50OII Exp Time	2x2	22
F28X50OII Overhead	5+1	28
F25QTZ Exp Time	19	47
F25QTZ Overhead	5	52
Orbit 2		
Guide star re-acquisition	5	5
G230L Exp Time	13	18
G230L Overhead	8	26
G140L Exp Time	17	43
G140L Overhead	8	51
Unused	1	52

A.5 WFPC2

Suppose that you wish to use the WFPC2 to observe a target at a declination of -45 degrees, so that there are 55 minutes of visibility time per orbit (see Table 6.1). Your desired exposures are listed in Table A.13 and the associated overheads are listed in Table A.14. In Table A.15 you can see how the observations fit into a total of 3 orbits.

Table A.13: WFPC2 Example: Planned Exposures

Config	Mode	Spectral Element	Num of Exp	Time per Exp [m]	Notes
WFPC2	IMAGING	F814W	1	40	CR-SPLIT
WFPC2	IMAGING	F450W	1	43	CR-SPLIT
WFPC2	IMAGING	F555W	4	9	Pattern (see Section 5.4) with an offset of 1" between positions

Table A.14: WFPC2 Example: Incurred Overheads

Overhead	Overhead Time [m]	Notes	see Table
Guide star acquisition	6	first orbit in new visit	6.2
Guide star re-acquisition	5	per orbit after first orbit	6.2
Exposure (CR-SPLIT)	5	per exposure (CR-SPLIT is default for >600s)	6.12
Exposure (no CR-SPLIT)	3	per exposure (no CR-SPLIT is default for <=600s)	6.12
Efficiency	1	per orbit	6.13
SAM of 1"	0.33	Small Angle Maneuver between positions in the pattern	6.14

Table A.15: WFPC2 Example: Orbit Planning

Activity	Duration [m]	Elapsed Time [m]
Orbit 1		
Guide star acquisition	6	6
F814W Exp Time	40	46
F814W Overhead	5	51
Efficiency Overhead	1	52
Unused	3	55
Orbit 2		
Guide star re-acquisition	5	5
F450W Exp Time	43	48
F450W Overhead	5	53
Efficiency Overhead	1	54
Unused	1	55
Orbit 3		
Guide star re-acquisition	5	5
F555W Exp Time	4x9	41
F555W Overhead	(4x3)+(3x0.33)	54
Efficiency Overhead	1	55

Archival Instruments

In this appendix . . .

B.1 Faint Object Camera (FOC) / 73
B.2 Faint Object Spectrograph (FOS) / 74
B.3 Goddard High Resolution Spectrograph (GHRS) / 75
B.4 High Speed Photometer (HSP) / 76
B.5 Wide Field and Planetary Camera 1 (WF/PC) / 76

Several instruments have been removed from HST after years of successful operation (see Section 2.1). The observations from these instruments in the HST Data Archive form a rich source of information for Archival Research. We therefore provide here a brief description of these instruments. Further details may be found in the most recent [Instrument Handbooks](#) for these instruments or in the HST [Data Handbook](#) (see Section 1.2).

B.1 Faint Object Camera (FOC)

The FOC was designed to provide high-resolution images of small fields. It consisted of two independent optical relays that magnify the input beam by a factor of four ($f/96$) and two ($f/48$). A variety of filters, prisms (for slitless spectroscopy), and polarizers could be placed in the optical beam. The $f/48$ relay also had a longslit spectrograph. The FOC photocathodes limited the wavelength range from 1200 to 6000 Angstroms.

When corrected by COSTAR, the field of view (FOV) and pixel size of the $f/96$ camera were 7" x 7" (512 x 512 format) and 0.014" x 0.014", respectively; a field of 14" x 14" could be used with the 512 x 1024 pixel format and a rectangular pixel size of 0.028" x 0.014". Without COSTAR in the beam, the corresponding parameters for the $f/96$ camera were: 11" x 11" FOV in the 512 x 512 format, pixel size 0.0223" x 0.0223" and full-format field of 22" x 22" with 0.0446" x 0.0223" pixels. The corresponding values for the (little used) $f/48$ camera were twice those of the $f/96$ camera.

The f/96 camera was the primary FOC imaging workhorse. High voltage instabilities limited the use of the f/48 relay to mainly long-slit spectroscopy after the installation of COSTAR.

Most of the FOC data in the archive are unique because the spatial resolution of the FOC is greater than that of any current (or planned) HST instrument. Also, the UV sensitivity was significantly higher than WFPC2, but less than STIS, although a larger variety of filters was available. Finally, the polarizers in the f/96 relay had very low instrumental polarization and excellent polarizing efficiencies.

B.2 Faint Object Spectrograph (FOS)

The FOS (now in the Smithsonian National Air and Space Museum in Washington, D.C.) performed low and moderate resolution spectroscopy ($R \sim 250$ and 1300) in the wavelength range 1150 to 8500 \AA . A variety of apertures of different sizes and shapes were available which could optimize throughput and spectral or spatial resolution. Ultraviolet linear and circular spectropolarimetric capability was also available.

The low resolution mode had two gratings and a prism, and the $R = 1300$ mode had six gratings to cover the entire spectral range. The photon-counting detectors consisted of two 512-element Digicons, one which operated from 1150 to 5500 \AA (FOS/BLUE), and the other from 1620 to 8500 \AA (FOS/RED).

Most FOS data were acquired in accumulation and rapid-readout modes; periodic and image modes were used infrequently. Time resolutions as short as 30 msec were feasible. The electron image was magnetically stepped through a programmed pattern during the observations which provided for oversampling, compensation for sensitivity variations along the Digicon array, sky measures and/or measurement of orthogonally polarized spectra. Normally, data were read out in intervals that were short compared to the exposure time.

The FOS received about 20–25% of the total HST observing time over Cycles 1–6, studying a large and diverse range of science topics. Due to the polarimetric and large dynamic range capabilities a substantial fraction of these data is and will remain unique.

A major reprocessing of the entire FOS archive, which will substantially improve the data quality and homogeneity, has been completed at the Space Telescope--European Coordinating Facility.

B.3 Goddard High Resolution Spectrograph (GHRS)

The GHRS had two, 500-element digicon detectors, which provided sensitivity from 1100 to 1900 Å (Side 1—solar blind) and 1150 to 3200 Å (Side 2); these detectors offered photon-noise limited data if an observing strategy was undertaken to map out photocathode response irregularities with the FP-SPLIT option. Signal-to-noise ratios of 100 or more were routinely achieved, and upwards of 1000 on occasion.

The GHRS modes included a first order grating covering 1100–1900 Å at $R \sim 2,500$ (285 Å bandpass), four first order holographic gratings with very low scattered light covering 1150–3200 Å at $R \sim 25,000$ (27–45 Å bandpass), and cross-dispersed echelles at $R \sim 80,000$ over 1150–3200 Å (6–15 Å bandpass).

The GHRS had two apertures: the 2.0" Large Science Aperture (LSA), and 0.25" Small Science Aperture (SSA); post-COSTAR the aperture projections were reduced to 1.74" and 0.22" respectively. The SSA projected to one resolution element; thus, even pre-COSTAR data taken with this aperture had the designed spectral resolution, albeit at reduced throughput.

Some data were acquired at time resolutions as short as 50 milli-seconds in a Rapid Readout mode. Most observations were acquired in accumulation mode, which provided for oversampling, compensation for sensitivity variations along the Digicon array, and simultaneous monitoring of detector backgrounds. Routine observations of the onboard Pt-Ne emission line lamp provided data with well calibrated wavelengths.

The GHRS received about 20–25% of the total HST observing time over Cycles 1–6, resulting in a large and diverse range of high quality science data. Due to the high signal-to-noise ratio and large dynamic range capabilities in the far ultraviolet, much of this data is unique.

B.4 High Speed Photometer (HSP)

The HSP was designed to take advantage of the lack of atmospheric scintillation for a telescope in orbit, as well as to provide good ultraviolet performance. Integrations as short as 10 μs were possible, over a broad wavelength range (1200 to 8000 \AA), and polarimetry was also possible. Observations were carried out through aperture diameters of 1.0" with the visual and ultraviolet detectors, and 0.65" with the polarimetry detector.

HSP had a large variety of fixed aperture/filter combinations distributed in the focal plane; selection was accomplished by moving the telescope so as to place the target in the desired aperture behind the desired filter.

The HSP detectors consisted of four image-dissector tubes and one photomultiplier tube. A variety of ultraviolet and visual filters and polarizers was available. This instrument was used for only a relatively small fraction (5%) of HST observing in Cycles 1–3, since the HSP science program was among the more severely compromised by spherical aberration. Only limited instrument expertise is available at STScI in support of HSP Archival Research. The extremely high speed with which some HSP data was acquired make these data still unique for either past, current or planned HST capabilities.

B.5 Wide Field and Planetary Camera 1 (WF/PC)

The WF/PC had two configurations; in both, the FOV was covered by a mosaic of four charge-coupled devices (CCDs). Each CCD had 800×800 pixels and was sensitive from 1150 to 11,000 \AA . However, internal contaminants on the camera optics limited normal operation to the range from 2840 to 11,000 \AA .

In the Wide Field Camera (low-resolution) configuration, the FOV was 2.6' x 2.6', with a pixel size of 0.10". In the Planetary Camera (high-resolution) configuration, the FOV was 1.1' x 1.1' and the pixel size was 0.043". A variety of filters was available. The WF/PC received about 40% of the observing time on HST in Cycles 1–3, resulting in a large and diverse range of science data. All WF/PC data was severely affected by the spherical aberration. Unique and valuable data exists in the archive, but in terms of photometric accuracy, and especially image quality, data taken after the first servicing mission with (e.g., with the WFPC2) is superior.

Glossary of Acronyms and Abbreviations

ACQ	Acquisition
ACS	Advanced Camera for Surveys
APT	Astronomers Proposal Tools
CADC	Canadian Astronomy Data Centre
CCD	Charge-Coupled Device
COS	Cosmic Origins Spectrograph
COSTAR	Corrective Optics Space Telescope Axial Replacement
CTE	Charge Transfer Efficiency
CVZ	Continuous Viewing Zone
DADS	Data Archive and Distribution System
DD	Director's Discretionary
ESA	European Space Agency
ETC	Exposure Time Calculator
FGS	Fine Guidance Sensor(s)
FITS	Flexible Image Transport System
FOC	Faint Object Camera
FOS	Faint Object Spectrograph
FOV	Field of View
FUV	Far Ultraviolet
GHRS	Goddard High Resolution Spectrograph
GO	General Observer

78 ■ Appendix C: Glossary of Acronyms and Abbreviations

GSC	Guide Star Catalog
GSFC	Goddard Space Flight Center
GTO	Guaranteed Time Observer
HRC	High Resolution Channel
HSP	High Speed Photometer
HST	Hubble Space Telescope
HTML	Hyper Text Markup Language
IFOV	Instantaneous Field of View
IRAF	Image Reduction and Analysis Facility
LOW	Low Sky Background
LRF	Linear Ramp Filter
MAMA	Multi-Anode Microchannel Array
mas	milli arcsecond
MAST	Multimission Archive at STScI
NASA	National Aeronautics and Space Administration
NED	NASA/IPAC Extragalactic Database
NCS	NICMOS Cooling System
NICMOS	Near Infrared Camera and Multi-Object Spectrometer
NOAO	National Optical Astronomy Observatories
NUV	Near Ultraviolet
OMS	Observatory Monitoring System
OTA	Optical Telescope Assembly
OTFC	On The Fly Calibration
OTFR	On The Fly Reprocessing
PAM	Pupil Alignment Mechanism
PC	Planetary Camera
PCS	Pointing Control System
PDF	Portable Document Format
PI	Principal Investigator
POS	Position Mode
PSF	Point Spread Function
RPS2	Remote Proposal Submission 2
SAA	South Atlantic Anomaly

SAM	Small Angle Maneuver
SBC	Solar Blind Channel
SHD	Shadow Time
SI	Scientific Instrument
SIMBAD	Set of Identifications, Measurements and Bibliography for Astronomical Data
SM	Servicing Mission
SSM	Support Systems Module
SSR	Solid State Recorder
ST-ECF	Space Telescope - European Coordinating Facility
STIS	Space Telescope Imaging Spectrograph
STOCC	Space Telescope Operations Control Center
STScI	Space Telescope Science Institute
STSDAS	Space Telescope Science Data Analysis Software
TDRSS	Tracking and Data Relay Satellite System
TRANS	Transfer Mode
UV	Ultraviolet
VTT	Visual Target Tuner
WFC	Wide Field Camera (on WFPC2) or Wide Field Channel (on ACS)
WF/PC	Wide Field and Planetary Camera 1
WFPC2	Wide Field and Planetary Camera 2
WFC3	Wide Field Camera 3

Internet Links

ACS Instrument

<http://www.stsci.edu/hst/acs/>

APT Web Page

<http://apt.stsci.edu/>

Canadian Astronomy Data Centre

<http://cadwww.hia.nrc.ca/>

CVZ Tables on the Web

http://www.stsci.edu/spd/cycle12/CVZ_Tables.html

Cycle 12 Announcement Web Page

<http://www.stsci.edu/spd/cycle12/announce.html>

Data Handbook

http://www.stsci.edu/hst/HST_overview/documents/datahandbook/

Digitized Sky Survey (DSS)

<http://archive.stsci.edu/dss/>

Image Reduction and Analysis Facility (IRAF) Web Page

<http://iraf.noao.edu/iraf-homepage.html>

MAST Web Page

<http://archive.stsci.edu/>

NASA/IPAC Extragalactic Database (NED)

<http://nedwww.ipac.caltech.edu/>

NICMOS Instrument

<http://www.stsci.edu/hst/nicmos/>

Phase II Program Preparation Web Page

<http://presto.stsci.edu/public/rps2home.html>

Scientific Instruments Web Page

http://www.stsci.edu/hst/HST_overview/instruments

**Set of Identifications, Measurements and Bibliography for
Astronomical Data
(SIMBAD)**

<http://simbad.u-strasbg.fr/Simbad>

Space Telescope - European Coordinating Facility

<http://www.stecf.org/>

**Space Telescope Science Data Analysis Software (STSDAS)
Web Page**

<http://stdas.stsci.edu/STSDAS.html>

Space Telescope Science Institute

<http://www.stsci.edu/>

Starview Web Page

<http://starview.stsci.edu/>

STIS Instrument

<http://www.stsci.edu/hst/stis/>

TinyTim Web Page

<http://www.stsci.edu/software/tinytim/>

WFPC2 Instrument

<http://www.stsci.edu/instruments/wfpc2/>