



10500 - Exploring the Bottom End of the White Dwarf Cooling Sequence in the Galactic Open Cluster NGC2158

Cycle: 14, Proposal Category: GO

(Availability Mode: SUPPORTED)

INVESTIGATORS

<i>Name</i>	<i>Institution</i>	<i>E-Mail</i>
Dr. Luigi R. Bedin (PI) (ESA Member)	European Southern Observatory - Germany	lbedin@eso.org
Prof. Giampaolo Piotto (CoI) (ESA Member) (Contact)	Universita di Padova	piotto@pd.astro.it
Dr. Ivan R. King (CoI) (AdminUSPI)	University of Washington	king@astro.washington.edu
Dr. Jay Anderson (CoI)	Rice University	jay@bevo.rice.edu
Dr. Maurizio Salaris (CoI) (ESA Member)	Liverpool John Moores University	ms@astro.livjm.ac.uk
Dr. Yazan Momany (CoI) (ESA Member)	Universita di Padova	momany@pd.astro.it
Dr. Santi Cassisi (CoI) (ESA Member)	INAF, Osservatorio Astronomico di Teramo	cassisi@astrte.te.astro.it

VISITS

<i>Visit</i>	<i>Targets</i>	<i>Configurations</i>	<i>Orbits Used</i>	<i>Last Orbit Planner Run</i>	<i>OP Current with Visit?</i>
01	(1) NGC-2158-OFF	ACS/WFC WFPC2	5	05-Jul-2005 21:35:38.0	yes
02	(1) NGC-2158-OFF	ACS/WFC WFPC2	5	05-Jul-2005 21:36:02.0	yes

10 Total Orbits Used

ABSTRACT

The recent discovery by our group of an unexpectedly bright and still unexplained peak in the white dwarf (WD) luminosity function (LF) of the metal rich, old open cluster NGC6791 casts serious doubts on our understanding of the physical process which rules the formation and the cooling of WDs. In order to investigate whether the same problem is present in other open clusters with different ages and metallicities, we propose deep ACS/HST observations reaching the bottom end of the WD LFs, for the first time in a young and so populous Galactic open cluster: NGC2158.

OBSERVING DESCRIPTION

We propose to study the white dwarf cooling sequence (WDCS) of the open cluster NGC2158 with ACS/WFC. Other goals of this proposal are: i) determination of proper motions, in order to discern cluster members, from foreground blue stars ii) study the bright part of the WDCS in the outskirts of the clusters using WFPC2 parallel fields for which there will be no proper motions. To get proper motions for the stars in the ACS/WFC field we split our observations into two visits, with a separation of at least 6 months. We found that in 2-gyro mode we could get a 13-month separation between visits. This also gives us WFPC2 parallel observations in different locations in the cluster, so that we have more field-coverage for better statistics of the outer cluster population.

ADDITIONAL COMMENTS

In order to ensure a sufficient time baseline between the epochs, it is important to take the first visit during its earliest window (Oct 2005), and the second visit during its latest window (Nov 2006).

Proposal 10500 - Visit 01 - Exploring the Bottom End of the White Dwarf Cooling Sequence in the Galactic Open Cluster NGC2158

Wed Jul 06 01:36:07 GMT 2005

Visit	Proposal 10500, Visit 01									
	Diagnostic Status: No Diagnostics									
Scientific Instruments: ACS/WFC, WFPC2										
Special Requirements: ORIENT 180.0D TO 252.5 D; BETWEEN 24-OCT-2005:00:00:00 AND 29-OCT-2005:00:00:00										
<i>Comments: This is the first epoch visit</i>										
Fixed Targets	#	Name	Target Coordinates	Targ. Coord. Corrections	Fluxes	Miscellaneous				
	(1)	NGC-2158-OFF Alt Name1: nonmirompereic.	RA: 06 07 35.2740 (91.8969750d) Dec: +24 06 1.48 (24.10041d) Equinox: J2000 Plate Id: (?)		V=28.2	Coordinate Source: DSS				
Exposures	#	Label	Target	Config,Mode,Aperture	Spectral Els.	Opt. Params.	Special Reqs.	Groups	Exp. Time/[Actual Dur.]	Orbit
	1	F814W_AC S_01short	(1) NGC-2158-OFF	ACS/WFC, ACCUM, WFCENTER	F814W	CR-SPLIT=NO; GAIN=2			0.5 Secs [==>]	[1]
	2	F606W_AC S_01long	(1) NGC-2158-OFF	ACS/WFC, ACCUM, WFCENTER	F606W	GAIN=2; CR-SPLIT=NO		Prime + Parallel Group up 2-3	1145.0 Secs [==>]	[1]
	3	F606W_WF PC2_01long	(1) NGC-2158-OFF	WFPC2, IMAGE, WFALL	F606W	ATD-GAIN=7; CR-SPLIT=NO		Prime + Parallel Group up 2-3	900.0 Secs [==>]	[1]
	4	F814W_AC S_01long	(1) NGC-2158-OFF	ACS/WFC, ACCUM, WFCENTER	F814W	GAIN=2; CR-SPLIT=NO		Prime + Parallel Group up 4-5	1130.0 Secs [==>]	[1]
	5	F814W_WF PC2_01long	(1) NGC-2158-OFF	WFPC2, IMAGE, WFALL	F814W	ATD-GAIN=7; CR-SPLIT=NO		Prime + Parallel Group up 4-5	900.0 Secs [==>]	[1]
	6	F814W_AC S_02short	(1) NGC-2158-OFF	ACS/WFC, ACCUM, WFCENTER	F814W	CR-SPLIT=NO; GAIN=2	POS TARG 0.52,0.2 7		20.0 Secs [==>]	[2]
	7	F606W_AC S_02long	(1) NGC-2158-OFF	ACS/WFC, ACCUM, WFCENTER	F606W	GAIN=2; CR-SPLIT=NO	POS TARG 0.52,0.2 7	Prime + Parallel Group up 7-8	1150.0 Secs [==>]	[2]
	8	F606W_WF PC2_02long	(1) NGC-2158-OFF	WFPC2, IMAGE, WFALL	F606W	ATD-GAIN=7; CR-SPLIT=NO		Prime + Parallel Group up 7-8	900.0 Secs [==>]	[2]
	9	F814W_AC S_02long	(1) NGC-2158-OFF	ACS/WFC, ACCUM, WFCENTER	F814W	GAIN=2; CR-SPLIT=NO	POS TARG 0.52,0.2 7	Prime + Parallel Group up 9-10	1150.0 Secs [==>]	[2]
	10	F814W_WF PC2_02long	(1) NGC-2158-OFF	WFPC2, IMAGE, WFALL	F814W	ATD-GAIN=7; CR-SPLIT=NO		Prime + Parallel Group up 9-10	900.0 Secs [==>]	[2]
	11	F814W_AC S_03short	(1) NGC-2158-OFF	ACS/WFC, ACCUM, WFCENTER	F814W	CR-SPLIT=NO; GAIN=2	POS TARG 0.29,0.5 2		20.0 Secs [==>]	[3]
	12	F606W_AC S_03long	(1) NGC-2158-OFF	ACS/WFC, ACCUM, WFCENTER	F606W	GAIN=2; CR-SPLIT=NO	POS TARG 0.29,0.5 2	Prime + Parallel Group up 12-13	1150.0 Secs [==>]	[3]
13	F606W_WF PC2_03long	(1) NGC-2158-OFF	WFPC2, IMAGE, WFALL	F606W	ATD-GAIN=7; CR-SPLIT=NO		Prime + Parallel Group up 12-13	900.0 Secs [==>]	[3]	

Proposal 10500 - Visit 01 - Exploring the Bottom End of the White Dwarf Cooling Sequence in the Galactic Open Cluster NGC2158

#	Label	Target	Config,Mode,Aperture	Spectral Els.	Opt. Params.	Special Reqs.	Groups	Exp. Time/[Actual Dur.]	Orbit	
Exposures (continued)	14	F814W_AC S_03long	(1) NGC-2158-OFF	ACS/WFC, ACCUM, WFCENTER	F814W	GAIN=2; CR-SPLIT=NO	POS TARG 0.29,0.5 2	Prime + Parallel Group up 14-15	1150.0 Secs [==>]	[3]
	15	F814W_WF PC2_03long	(1) NGC-2158-OFF	WFPC2, IMAGE, WFALL	F814W	ATD-GAIN=7; CR-SPLIT=NO		Prime + Parallel Group up 14-15	900.0 Secs [==>]	[3]
	16	F606W_AC S_01short	(1) NGC-2158-OFF	ACS/WFC, ACCUM, WFCENTER	F606W	CR-SPLIT=NO; GAIN=2	POS TARG 0.01,3.0 3		20.0 Secs [==>]	[4]
	17	F606W_AC S_04long	(1) NGC-2158-OFF	ACS/WFC, ACCUM, WFCENTER	F606W	GAIN=2; CR-SPLIT=NO	POS TARG 0.01,3.0 3	Prime + Parallel Group up 17-18	1150.0 Secs [==>]	[4]
	18	F606W_WF PC2_04long	(1) NGC-2158-OFF	WFPC2, IMAGE, WFALL	F606W	ATD-GAIN=7; CR-SPLIT=NO		Prime + Parallel Group up 17-18	900.0 Secs [==>]	[4]
	19	F814W_AC S_04long	(1) NGC-2158-OFF	ACS/WFC, ACCUM, WFCENTER	F814W	GAIN=2; CR-SPLIT=NO	POS TARG 0.01,3.0 3	Prime + Parallel Group up 19-20	1150.0 Secs [==>]	[4]
	20	F814W_WF PC2_04long	(1) NGC-2158-OFF	WFPC2, IMAGE, WFALL	F814W	ATD-GAIN=7; CR-SPLIT=NO		Prime + Parallel Group up 19-20	900.0 Secs [==>]	[4]
	21	F606W_AC S_02short	(1) NGC-2158-OFF	ACS/WFC, ACCUM, WFCENTER	F606W	CR-SPLIT=NO; GAIN=2	POS TARG 0.28,3.2 9		20.0 Secs [==>]	[5]
	22	F606W_AC S_05long	(1) NGC-2158-OFF	ACS/WFC, ACCUM, WFCENTER	F606W	GAIN=2; CR-SPLIT=NO	POS TARG 0.28,3.2 9	Prime + Parallel Group up 22-23	1150.0 Secs [==>]	[5]
	23	F606W_WF PC2_05long	(1) NGC-2158-OFF	WFPC2, IMAGE, WFALL	F606W	ATD-GAIN=7; CR-SPLIT=NO		Prime + Parallel Group up 22-23	900.0 Secs [==>]	[5]
	24	F814W_AC S_05long	(1) NGC-2158-OFF	ACS/WFC, ACCUM, WFCENTER	F814W	GAIN=2; CR-SPLIT=NO	POS TARG 0.28,3.2 9	Prime + Parallel Group up 24-25	1150.0 Secs [==>]	[5]
	25	F814W_WF PC2_02long	(1) NGC-2158-OFF	WFPC2, IMAGE, WFALL	F814W	ATD-GAIN=7; CR-SPLIT=NO		Prime + Parallel Group up 24-25	900.0 Secs [==>]	[5]

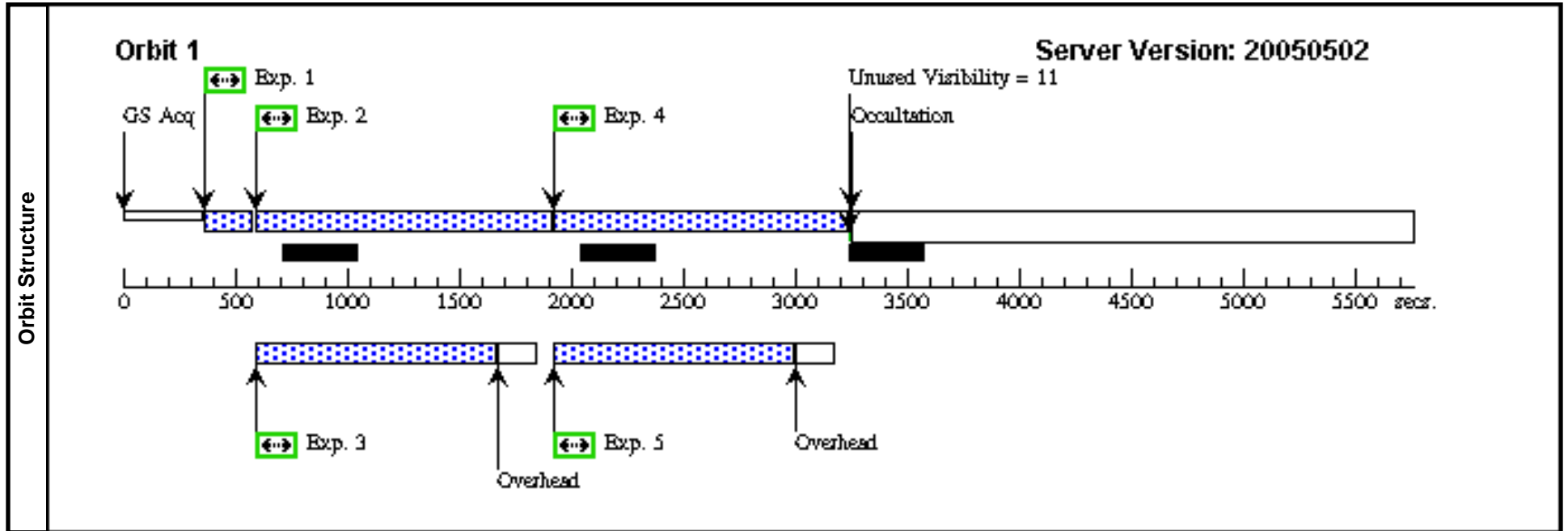

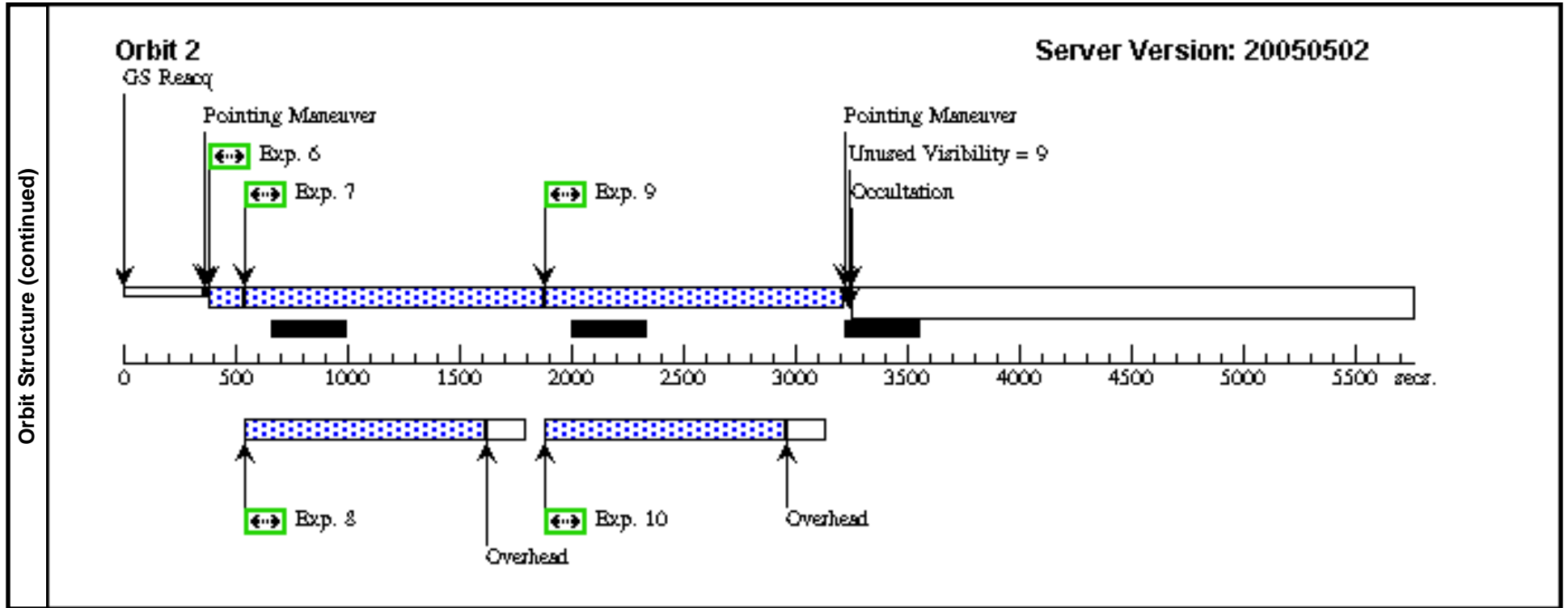

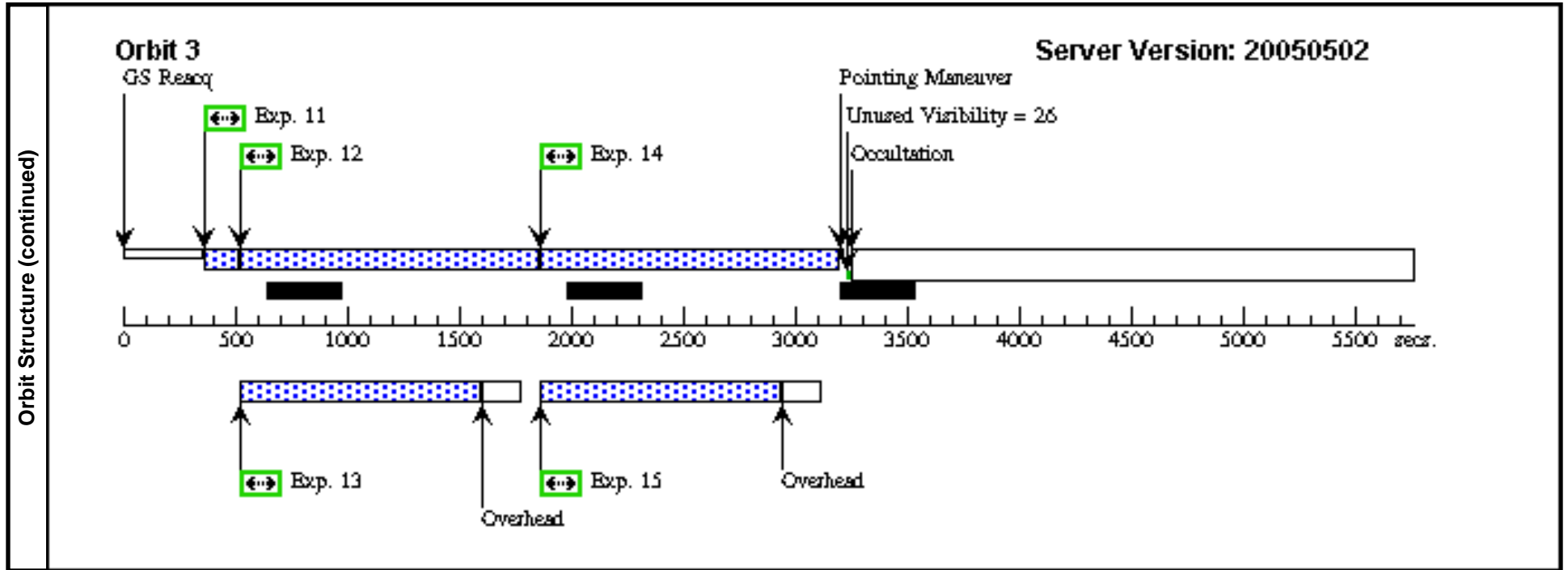

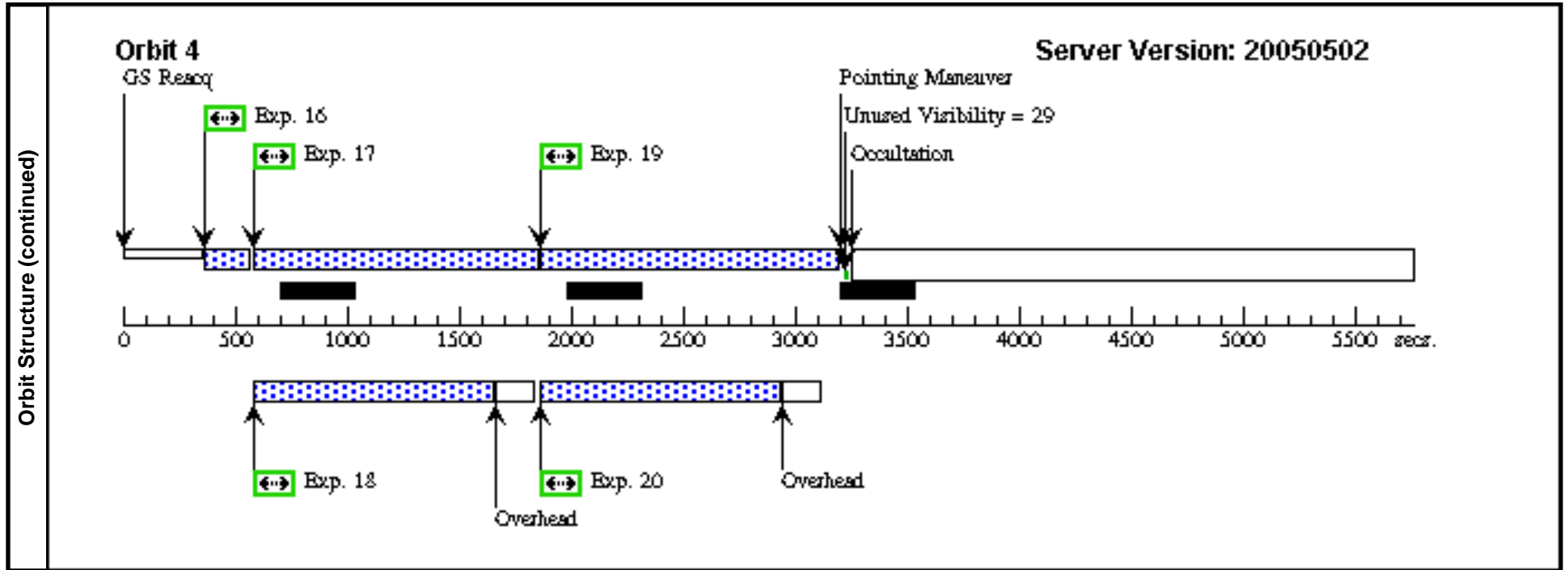

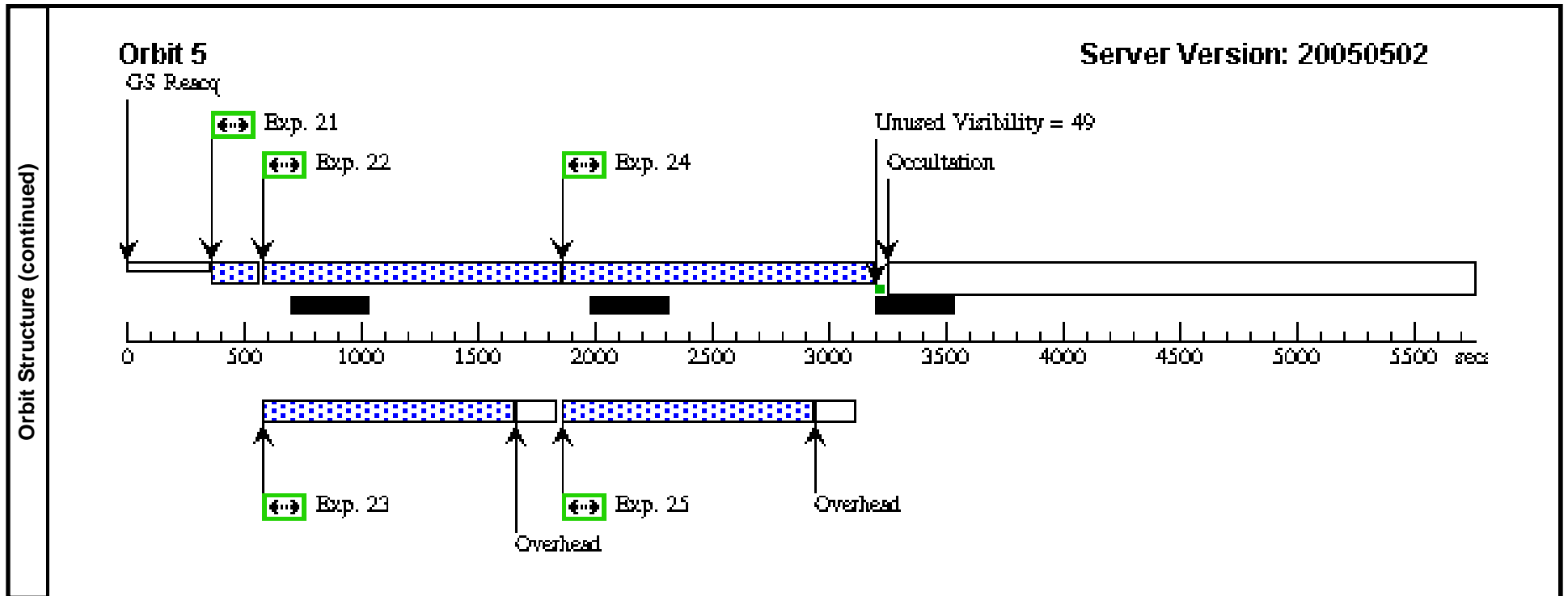

Proposal 10500 - Visit 02 - Exploring the Bottom End of the White Dwarf Cooling Sequence in the Galactic Open Cluster NGC2158

Wed Jul 06 01:36:10 GMT 2005

Visit	Proposal 10500, Visit 02									
	Diagnostic Status: No Diagnostics									
Scientific Instruments: ACS/WFC, WFPC2										
Special Requirements: ORIENT 285.0D TO 330.0 D; BETWEEN 09-NOV-2006:00:00:00 AND 22-NOV-2006:00:00:00										
<i>Comments: This is the second epoch visit</i>										
Fixed Targets	#	Name	Target Coordinates	Targ. Coord. Corrections	Fluxes	Miscellaneous				
	(1)	NGC-2158-OFF Alt Name1: nonmirompereic.	RA: 06 07 35.2740 (91.8969750d) Dec: +24 06 1.48 (24.10041d) Equinox: J2000 Plate Id: (?)		V=28.2	Coordinate Source: DSS				
Exposures	#	Label	Target	Config,Mode,Aperture	Spectral Els.	Opt. Params.	Special Reqs.	Groups	Exp. Time/[Actual Dur.]	Orbit
	1	F606W_AC S_03short	(1) NGC-2158-OFF	ACS/WFC, ACCUM, WFCENTER	F606W	CR-SPLIT=NO; GAIN=2			0.5 Secs [==>]	[1]
	2	F606W_AC S_01long	(1) NGC-2158-OFF	ACS/WFC, ACCUM, WFCENTER	F606W	GAIN=2; CR-SPLIT=NO		Prime + Parallel Group up 2-3	1145.0 Secs [==>]	[1]
	3	F606W_WF PC2_01long	(1) NGC-2158-OFF	WFPC2, IMAGE, WFALL	F606W	ATD-GAIN=7; CR-SPLIT=NO		Prime + Parallel Group up 2-3	900.0 Secs [==>]	[1]
	4	F814W_AC S_01long	(1) NGC-2158-OFF	ACS/WFC, ACCUM, WFCENTER	F814W	GAIN=2; CR-SPLIT=NO		Prime + Parallel Group up 4-5	1130.0 Secs [==>]	[1]
	5	F814W_WF PC2_01long	(1) NGC-2158-OFF	WFPC2, IMAGE, WFALL	F814W	ATD-GAIN=7; CR-SPLIT=NO		Prime + Parallel Group up 4-5	900.0 Secs [==>]	[1]
	6	F606W_AC S_04short	(1) NGC-2158-OFF	ACS/WFC, ACCUM, WFCENTER	F606W	CR-SPLIT=NO; GAIN=2	POS TARG 0.52,0.2 7		20.0 Secs [==>]	[2]
	7	F606W_AC S_02long	(1) NGC-2158-OFF	ACS/WFC, ACCUM, WFCENTER	F606W	GAIN=2; CR-SPLIT=NO	POS TARG 0.52,0.2 7	Prime + Parallel Group up 7-8	1150.0 Secs [==>]	[2]
	8	F606W_WF PC2_02long	(1) NGC-2158-OFF	WFPC2, IMAGE, WFALL	F606W	ATD-GAIN=7; CR-SPLIT=NO		Prime + Parallel Group up 7-8	900.0 Secs [==>]	[2]
	9	F814W_AC S_02long	(1) NGC-2158-OFF	ACS/WFC, ACCUM, WFCENTER	F814W	GAIN=2; CR-SPLIT=NO	POS TARG 0.52,0.2 7	Prime + Parallel Group up 9-10	1150.0 Secs [==>]	[2]
	10	F814W_WF PC2_02long	(1) NGC-2158-OFF	WFPC2, IMAGE, WFALL	F814W	ATD-GAIN=7; CR-SPLIT=NO		Prime + Parallel Group up 9-10	900.0 Secs [==>]	[2]
	11	F606W_AC S_05short	(1) NGC-2158-OFF	ACS/WFC, ACCUM, WFCENTER	F606W	CR-SPLIT=NO; GAIN=2	POS TARG 0.29,0.5 2		20.0 Secs [==>]	[3]
	12	F606W_AC S_03long	(1) NGC-2158-OFF	ACS/WFC, ACCUM, WFCENTER	F606W	GAIN=2; CR-SPLIT=NO	POS TARG 0.29,0.5 2	Prime + Parallel Group up 12-13	1150.0 Secs [==>]	[3]
13	F606W_WF PC2_03long	(1) NGC-2158-OFF	WFPC2, IMAGE, WFALL	F606W	ATD-GAIN=7; CR-SPLIT=NO		Prime + Parallel Group up 12-13	900.0 Secs [==>]	[3]	

Proposal 10500 - Visit 02 - Exploring the Bottom End of the White Dwarf Cooling Sequence in the Galactic Open Cluster NGC2158

#	Label	Target	Config,Mode,Aperture	Spectral Els.	Opt. Params.	Special Reqs.	Groups	Exp. Time/[Actual Dur.]	Orbit	
Exposures (continued)	14	F814W_AC S_03long	(1) NGC-2158-OFF	ACS/WFC, ACCUM, WFCENTER	F814W	GAIN=2; CR-SPLIT=NO	POS TARG 0.29,0.5 2	Prime + Parallel Group up 14-15	1150.0 Secs [==>]	[3]
	15	F814W_WF PC2_03long	(1) NGC-2158-OFF	WFPC2, IMAGE, WFALL	F814W	ATD-GAIN=7; CR-SPLIT=NO		Prime + Parallel Group up 14-15	900.0 Secs [==>]	[3]
	16	F814W_AC S_04short	(1) NGC-2158-OFF	ACS/WFC, ACCUM, WFCENTER	F814W	CR-SPLIT=NO; GAIN=2	POS TARG 0.01,3.0 3		20.0 Secs [==>]	[4]
	17	F606W_AC S_04long	(1) NGC-2158-OFF	ACS/WFC, ACCUM, WFCENTER	F606W	GAIN=2; CR-SPLIT=NO	POS TARG 0.01,3.0 3	Prime + Parallel Group up 17-18	1150.0 Secs [==>]	[4]
	18	F606W_WF PC2_04long	(1) NGC-2158-OFF	WFPC2, IMAGE, WFALL	F606W	ATD-GAIN=7; CR-SPLIT=NO		Prime + Parallel Group up 17-18	900.0 Secs [==>]	[4]
	19	F814W_AC S_04long	(1) NGC-2158-OFF	ACS/WFC, ACCUM, WFCENTER	F814W	GAIN=2; CR-SPLIT=NO	POS TARG 0.01,3.0 3	Prime + Parallel Group up 19-20	1150.0 Secs [==>]	[4]
	20	F814W_WF PC2_04long	(1) NGC-2158-OFF	WFPC2, IMAGE, WFALL	F814W	ATD-GAIN=7; CR-SPLIT=NO		Prime + Parallel Group up 19-20	900.0 Secs [==>]	[4]
	21	F814W_AC S_05short	(1) NGC-2158-OFF	ACS/WFC, ACCUM, WFCENTER	F814W	CR-SPLIT=NO; GAIN=2	POS TARG 0.28,3.2 9		20.0 Secs [==>]	[5]
	22	F606W_AC S_05long	(1) NGC-2158-OFF	ACS/WFC, ACCUM, WFCENTER	F606W	GAIN=2; CR-SPLIT=NO	POS TARG 0.28,3.2 9	Prime + Parallel Group up 22-23	1150.0 Secs [==>]	[5]
	23	F606W_WF PC2_05long	(1) NGC-2158-OFF	WFPC2, IMAGE, WFALL	F606W	ATD-GAIN=7; CR-SPLIT=NO		Prime + Parallel Group up 22-23	900.0 Secs [==>]	[5]
	24	F814W_AC S_05long	(1) NGC-2158-OFF	ACS/WFC, ACCUM, WFCENTER	F814W	GAIN=2; CR-SPLIT=NO	POS TARG 0.28,3.2 9	Prime + Parallel Group up 24-25	1150.0 Secs [==>]	[5]
	25	F814W_WF PC2_02long	(1) NGC-2158-OFF	WFPC2, IMAGE, WFALL	F814W	ATD-GAIN=7; CR-SPLIT=NO		Prime + Parallel Group up 24-25	900.0 Secs [==>]	[5]

