



10885 - Deep Photometry of NGC 1569: Understanding the Closest and Strongest Starburst of the Nearby Universe

Cycle: 15, Proposal Category: GO

(Availability Mode: SUPPORTED)

INVESTIGATORS

<i>Name</i>	<i>Institution</i>	<i>E-Mail</i>
Dr. Alessandra Aloisi (PI) (ESA Member)	Space Telescope Science Institute - ESA	aloisi@stsci.edu
Dr. Luca Angeretti (CoI) (ESA Member)	INAF, Osservatorio Astronomico di Bologna	luca.angeretti@bo.astro.it
Dr. Francesca Annibali (CoI)	Space Telescope Science Institute	annibali@stsci.edu
Dr. Laura Greggio (CoI) (ESA Member)	INAF, Osservatorio Astronomico di Padova	greggio@pd.astro.it
Dr. Enrico V. Held (CoI) (ESA Member)	INAF, Osservatorio Astronomico di Padova	held@pd.astro.it
Ms. Jennifer Mack (CoI)	Space Telescope Science Institute	mack@stsci.edu
Dr. Donatella Romano (CoI) (ESA Member)	INAF, Osservatorio Astronomico di Bologna	donatella.romano@bo.astro.it
Dr. Marco Sirianni (CoI) (ESA Member)	Space Telescope Science Institute - ESA	sirianni@stsci.edu
Dr. Monica Tosi (CoI) (ESA Member)	INAF, Osservatorio Astronomico di Bologna	monica.tosi@bo.astro.it
Dr. Roeland P. van der Marel (CoI) (AdminUSPI)	Space Telescope Science Institute	marel@stsci.edu

VISITS

<i>Visit</i>	<i>Targets</i>	<i>Configurations</i>	<i>Orbits Used</i>	<i>Last Orbit Planner Run</i>	<i>OP Current with Visit?</i>
01	(1) NGC1569 ANY	ACS/WFC WFPC2	4	01-Aug-2006 22:48:15.0	yes
02	(1) NGC1569 ANY	ACS/WFC WFPC2	4	01-Aug-2006 22:48:39.0	yes

Proposal 10885 - Overview

<i>Visit</i>	<i>Targets</i>	<i>Configurations</i>	<i>Orbits Used</i>	<i>Last Orbit Planner Run</i>	<i>OP Current with Visit?</i>
03	(1) NGC1569 ANY	ACS/WFC WFPC2	4	01-Aug-2006 22:48:58.0	yes
04	(1) NGC1569 ANY	ACS/WFC WFPC2	2	01-Aug-2006 22:49:08.0	yes
05	(1) NGC1569 ANY	ACS/WFC WFPC2	2	01-Aug-2006 22:49:18.0	yes
06	(1) NGC1569 ANY	ACS/WFC WFPC2	3	01-Aug-2006 22:49:30.0	yes

19 Total Orbits Used

ABSTRACT

Massive starbursts drive the evolution of galaxies at high redshift, but they can only be studied in detail in the nearby Universe where they are much rarer. The dwarf irregular galaxy NGC 1569 at 2.2 Mpc is the closest example of a true starburst. It has sustained exceptionally high star formation (SF) activity over the last Gyr, 2-3 orders of magnitude higher than in normal dwarf irregulars and spirals. This SF has been probed extensively by previous HST observations that have reached just below the tip of the red giant branch (RGB). But the data have not been able to constrain the more ancient SF history (SFH), so that our understanding remains very incomplete. It is an open question whether NGC 1569 just started to form stars around 1 Gyr ago, or whether significant SF was already active before that. We do not know what triggered the recent SF, how long the current intense SF activity has been going on, and whether such SF activity has been a more common occurrence in the past history of this galaxy. More importantly, most of these questions remain unanswered for other starburst galaxies in the nearby and distant universe as well. HST is the only telescope that can do the necessary crowded-field photometry to resolve these issues. We propose to use ACS/WFC to build a deep I vs. V-I color-magnitude diagram (CMD) that goes some 4 magnitudes deeper than the RGB tip. This will detect and characterize the red clump (RC) and horizontal branch (HB) features. The CMD will be interpreted by fitting synthetic CMDs constructed from evolutionary tracks to infer the SFH. The joint constraints from the presence, apparent magnitude, and width of the RC, HB and RGB features will independently constrain both the age and metallicity of the old and evolved stellar population of NGC 1569, the presence of multiple bursts if any, and their duration and metallicity spread.

This will reveal the evolutionary status over cosmic time, and more generally will constrain the processes at play in the origin and evolution of galaxies. This project is only possible because of the high sensitivity of ACS, and it can be done very efficiently because of the location of NGC 1569 in the CVZ. Since NGC 1569 is so close, it may be the only nearby starburst for which these issues can be addressed in the foreseeable future.

OBSERVING DESCRIPTION

We will use ACS/WFC to study the resolved stellar population in a selected field offset from the center of NGC 1569. Our expertise suggests that the V and I filters are best suited for this type of investigation. We will thus observe in the two broad-band filters F606W and F814W. F606W is preferred to the narrower F555W because it is a broader filter with a much higher sensitivity. We will infer the ancient star formation history of NGC 1569 from simulations tailored to reproduce the observed I vs. V-I CMD. Since F606W includes H α , we will also acquire narrow-band imaging in F658N to correct the wide F606W filter for nebular contamination. Since this target is at high declination (+65 degrees), NGC 1569 can be efficiently observed in CVZ. This will allow the observations to be executed in half the number of orbits that it would otherwise take. We will acquire exposures at one pointing for 13 orbits in F606W, 5 orbits in F814W, and 1 orbit in F658N. The exposure times for the broad-band filters were chosen to reach the magnitude of the HB ($I = 27.7$ mag) with a photometric error below 0.1 mag ($S/N > 10$). The exposures per visit in each filter will be executed with standard primary+secondary dithering patterns suitable to get rid of cosmic rays, remove hot/bad pixels, fill the gap between the two CCDs of the ACS/WFC, and improve the PSF sampling. We want to carefully position a very bright ($V=10$ mag) foreground star outside of the ACS/WFC detector in order not to heavily compromise the observations with ghosts and saturation issues. Such goal restricts somehow the ORIENT of the observations. The visit planner shows that the observations can schedule for three 2-day periods in Sep 2006, Nov 2006, and Jan 2007, with a certain range of ORIENT. Since only up to 6 SAA-free orbits per day can be accommodated, we will acquire the data at 2 different ORIENTs, 12 orbits at an angle of 205 degrees (Nov 2006) and 5 orbits at 115 degrees (Jan 2007). These ORIENTs have been chosen to ensure the maximum overlapping area between the two different epochs. Finally, parallel WFPC2 observations will be taken in F606W (14 orbits) and F814W (5 orbits) and will target a couple of regions quite far away from the center of NGC1569 where an HI stream has been detected. At least in one region, such observations will go deep enough to detect RGB stars at the distance of NGC 1569. This will allow us to search for stars in the HI stream of NGC1569, if they exist.

Proposal 10885 - Overview

REAL TIME JUSTIFICATION

N/A

CALIBRATION JUSTIFICATION

N/A

ADDITIONAL COMMENTS

N/A

Proposal 10885 - Visit 01 - Deep Photometry of NGC 1569: Understanding the Closest and Strongest Starburst of the Nearby Universe

Wed Aug 02 02:49:34 GMT 2006

Visit	Proposal 10885, Visit 01 Diagnostic Status: Error Scientific Instruments: ACS/WFC, WFPC2 Special Requirements: CVZ; ORIENT 205.0D TO 205.0 D										
	Diagnostics	(WFPC2par (01.003)Pattern 2,3, Split 1) Error: Orbit number out of range (must be equal to 4 or 1 greater than that of the previous sub-exposure). To learn more about orbit numbers, please read the full error text in the Diagnostic Report.									
Patterns		#	Primary Pattern				Secondary Pattern				Exposures
	(1)	Pattern Type=ACS-WFC-DITHER-LINE Purpose=OTHER Number Of Points=2 Point Spacing=2.994 Line Spacing=	Coordinate Frame=POS-TARG Pattern Orientation=85.3 Angle Between Sides= Center Pattern=false	Pattern Type=ACS-WFC-DITHER-BOX Purpose=DITHER Number Of Points=4 Point Spacing=0.265 Line Spacing=0.187	Coordinate Frame=POS-TARG Pattern Orientation=20.7 Angle Between Sides=69.1 Center Pattern=false	(2-3)					
Fixed Targets	#	Name	Target Coordinates		Targ. Coord. Corrections	Fluxes	Miscellaneous				
	(1)	NGC1569	RA: 04 30 46.4052 (67.6933550d) Dec: +64 49 41.28 (64.82813d) Equinox: J2000			V=11.9	Reference Frame: ICRS				
<i>Comments: This object was generated by the targetselector and retrieved from the NED database.</i>											
Exposures	#	Label	Target	Config,Mode,Aperture	Spectral Els.	Opt. Params.	Special Reqs.	Groups	Exp. Time/[Actual Dur.]		Orbit
	1	ACSshort	(1) NGC1569	ACS/WFC, ACCUM, WFCENTER	F814W	CR-SPLIT=NO	POS TARG 0,0		3.0 Secs [==>]	[1]	

Proposal 10885 - Visit 01 - Deep Photometry of NGC 1569: Understanding the Closest and Strongest Starburst of the Nearby Universe

#	Label	Target	Config,Mode,Aperture	Spectral Els.	Opt. Params.	Special Reqs.	Groups	Exp. Time/[Actual Dur.]	Orbit
Exposures (continued)	2	ACSprime	(1) NGC1569	ACS/WFC, ACCUM, WFCENTER	F814W	CR-SPLIT=2	Pattern 2-3 (1) Prime + Parallel Group 2-3	2446.0 Secs	
								[==>(Pattern 1,1, Split 1)]	[1]
								[==>(Pattern 1,1, Split 2)]	
								[==>(Pattern 1,2, Split 1)]	
								[==>(Pattern 1,2, Split 2)]	
								[==>(Pattern 1,3, Split 1)]	[2]
								[==>(Pattern 1,3, Split 2)]	
								[==>(Pattern 1,4, Split 1)]	
	[==>(Pattern 1,4, Split 2)]								
	[==>(Pattern 2,1, Split 1)]	[3]							
	[==>(Pattern 2,1, Split 2)]								
	[==>(Pattern 2,2, Split 1)]								
	[==>(Pattern 2,2, Split 2)]								
	[==>(Pattern 2,3, Split 1)]	[4]							
	[==>(Pattern 2,3, Split 2)]								
	[==>(Pattern 2,4, Split 1)]								
[==>(Pattern 2,4, Split 2)]									
3	WFPC2par	ANY	WFPC2, IMAGE, WFALL	F814W			Pattern 2-3 (1) Prime + Parallel Group 2-3	2200.0 Secs	
								[==>(Pattern 1,1, Split 1)]	[1]
								[==>(Pattern 1,1, Split 2)]	
								[==>(Pattern 1,2, Split 1)]	
								[==>(Pattern 1,2, Split 2)]	
								[==>(Pattern 1,3, Split 1)]	[2]
								[==>(Pattern 1,3, Split 2)]	
								[==>(Pattern 1,4, Split 1)]	
	[==>(Pattern 1,4, Split 2)]								
	[==>(Pattern 2,1, Split 1)]	[3]							
	[==>(Pattern 2,1, Split 2)]								
	[==>(Pattern 2,2, Split 1)]								
	[==>(Pattern 2,2, Split 2)]								
	[==>(Pattern 2,3, Split 1)]	[4]							
	[==>(Pattern 2,3, Split 2)]								
	[==>(Pattern 2,4, Split 1)]								
[==>(Pattern 2,4, Split 2)]									

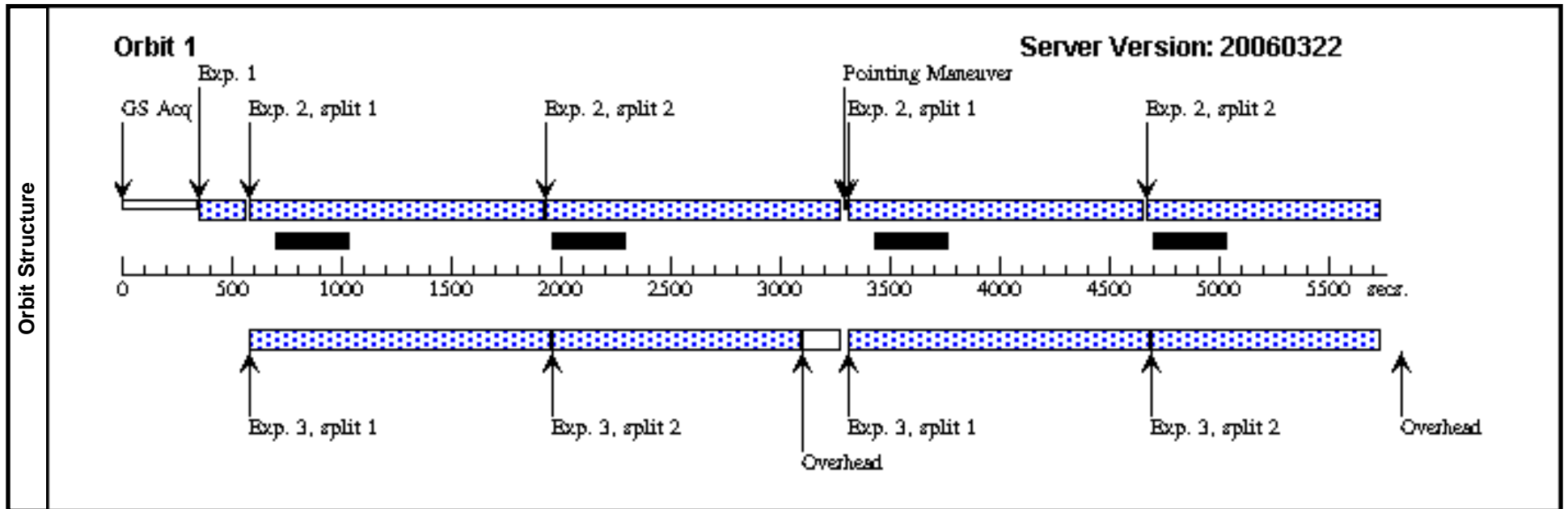

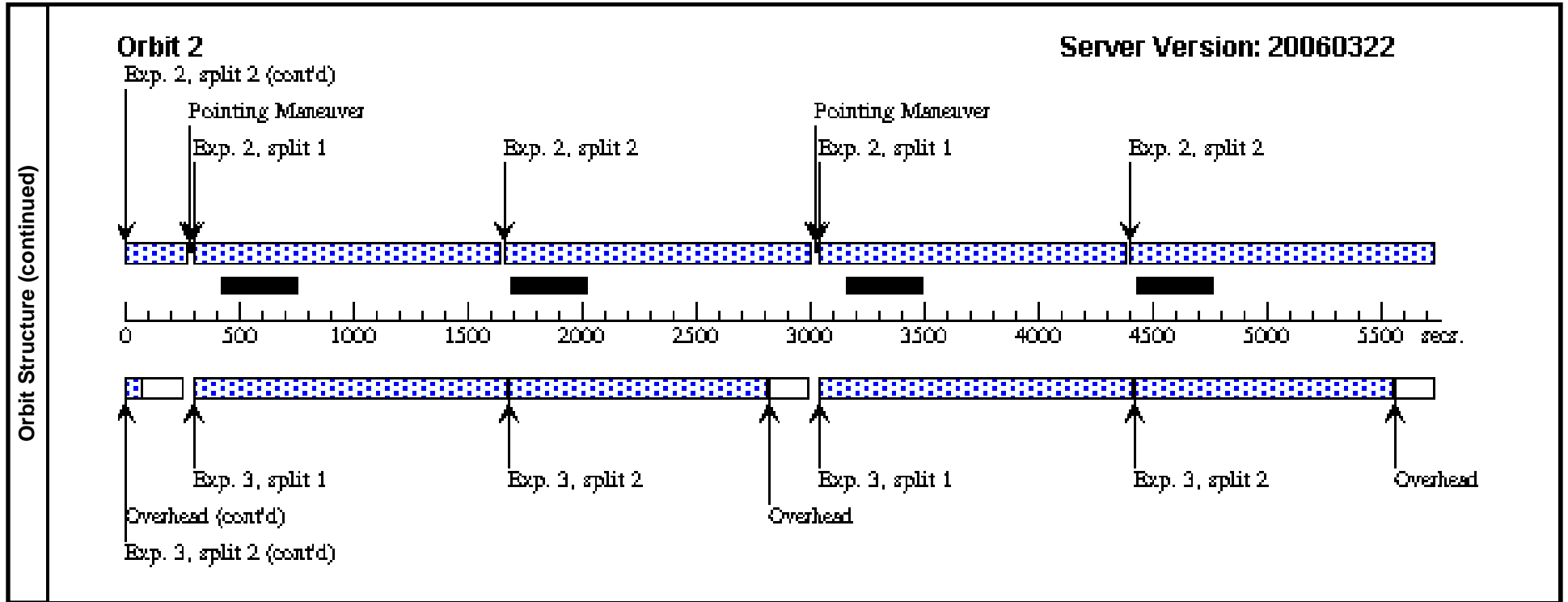

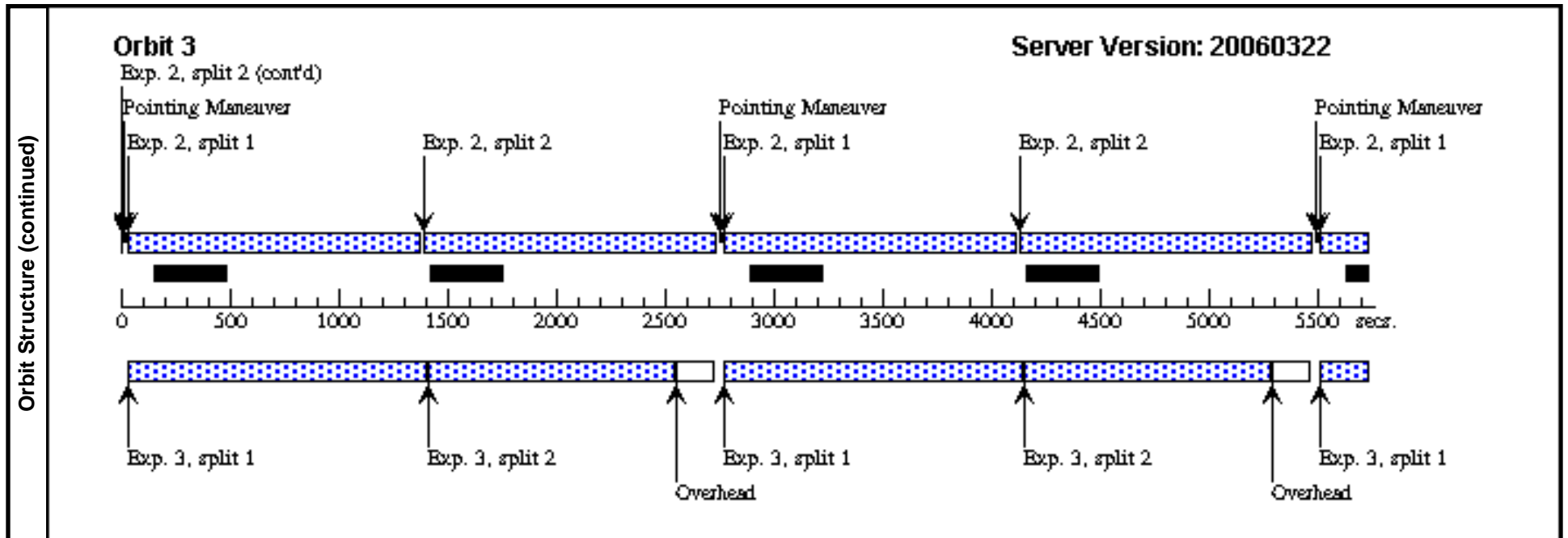

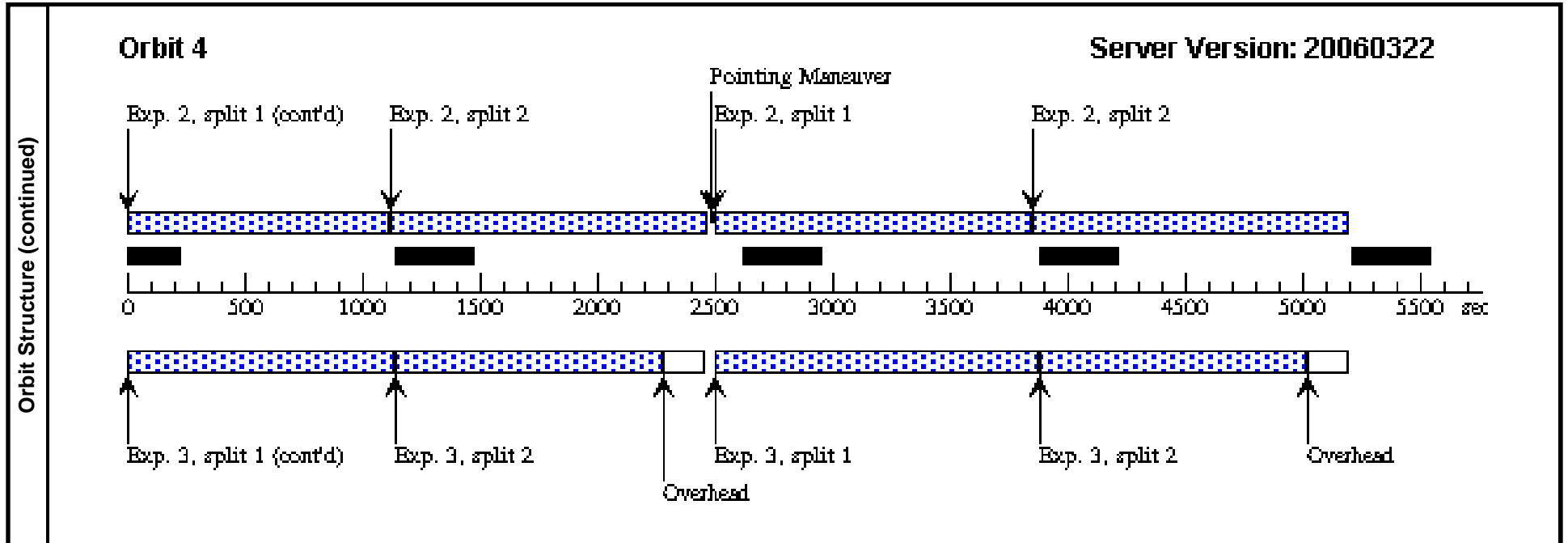

Proposal 10885 - Visit 02 - Deep Photometry of NGC 1569: Understanding the Closest and Strongest Starburst of the Nearby Universe

Wed Aug 02 02:49:37 GMT 2006

Visit	Proposal 10885, Visit 02 Diagnostic Status: Error Scientific Instruments: ACS/WFC, WFPC2 Special Requirements: CVZ; ORIENT 205.0D TO 205.0 D										
	Diagnostics	(WFPC2par (02.003)Pattern 2,3, Split 1) Error: Orbit number out of range (must be equal to 4 or 1 greater than that of the previous sub-exposure). To learn more about orbit numbers, please read the full error text in the Diagnostic Report.									
Patterns		#	Primary Pattern				Secondary Pattern				Exposures
	(1)	Pattern Type=ACS-WFC-DITHER-LINE Purpose=OTHER Number Of Points=2 Point Spacing=2.994 Line Spacing=	Coordinate Frame=POS-TARG Pattern Orientation=85.3 Angle Between Sides= Center Pattern=false	Pattern Type=ACS-WFC-DITHER-BOX Purpose=DITHER Number Of Points=4 Point Spacing=0.265 Line Spacing=0.187	Coordinate Frame=POS-TARG Pattern Orientation=20.7 Angle Between Sides=69.1 Center Pattern=false	(2-3)					
Fixed Targets	#	Name	Target Coordinates		Targ. Coord. Corrections		Fluxes	Miscellaneous			
	(1)	NGC1569	RA: 04 30 46.4052 (67.6933550d) Dec: +64 49 41.28 (64.82813d) Equinox: J2000					V=11.9	Reference Frame: ICRS		
<i>Comments: This object was generated by the targetselector and retrieved from the NED database.</i>											
Exposures	#	Label	Target	Config,Mode,Aperture	Spectral Els.	Opt. Params.	Special Reqs.	Groups	Exp. Time/[Actual Dur.]		Orbit
	1	ACSshort	(1) NGC1569	ACS/WFC, ACCUM, WFCENTER	F814W	CR-SPLIT=NO	POS TARG 0.247,2.984			3.0 Secs [==>]	[1]

Proposal 10885 - Visit 02 - Deep Photometry of NGC 1569: Understanding the Closest and Strongest Starburst of the Nearby Universe

#	Label	Target	Config,Mode,Aperture	Spectral Els.	Opt. Params.	Special Reqs.	Groups	Exp. Time/[Actual Dur.]	Orbit
Exposures (continued)	2	ACSprime	(1) NGC1569	ACS/WFC, ACCUM, WFCENTER	F606W	CR-SPLIT=2	Pattern 2-3 (1) Prime + Parallel Group 2-3	2446.0 Secs	
								[==>(Pattern 1,1, Split 1)]	[1]
								[==>(Pattern 1,1, Split 2)]	
								[==>(Pattern 1,2, Split 1)]	
								[==>(Pattern 1,2, Split 2)]	
								[==>(Pattern 1,3, Split 1)]	[2]
								[==>(Pattern 1,3, Split 2)]	
								[==>(Pattern 1,4, Split 1)]	
	[==>(Pattern 1,4, Split 2)]								
	[==>(Pattern 2,1, Split 1)]	[3]							
	[==>(Pattern 2,1, Split 2)]								
	[==>(Pattern 2,2, Split 1)]								
	[==>(Pattern 2,2, Split 2)]								
	[==>(Pattern 2,3, Split 1)]	[4]							
	[==>(Pattern 2,3, Split 2)]								
	[==>(Pattern 2,4, Split 1)]								
[==>(Pattern 2,4, Split 2)]									
3	WFPC2par	ANY	WFPC2, IMAGE, WFALL	F606W			Pattern 2-3 (1) Prime + Parallel Group 2-3	2200.0 Secs	
								[==>(Pattern 1,1, Split 1)]	[1]
								[==>(Pattern 1,1, Split 2)]	
								[==>(Pattern 1,2, Split 1)]	
								[==>(Pattern 1,2, Split 2)]	
								[==>(Pattern 1,3, Split 1)]	[2]
								[==>(Pattern 1,3, Split 2)]	
								[==>(Pattern 1,4, Split 1)]	
	[==>(Pattern 1,4, Split 2)]								
	[==>(Pattern 2,1, Split 1)]	[3]							
	[==>(Pattern 2,1, Split 2)]								
	[==>(Pattern 2,2, Split 1)]								
	[==>(Pattern 2,2, Split 2)]								
	[==>(Pattern 2,3, Split 1)]	[4]							
	[==>(Pattern 2,3, Split 2)]								
	[==>(Pattern 2,4, Split 1)]								
[==>(Pattern 2,4, Split 2)]									

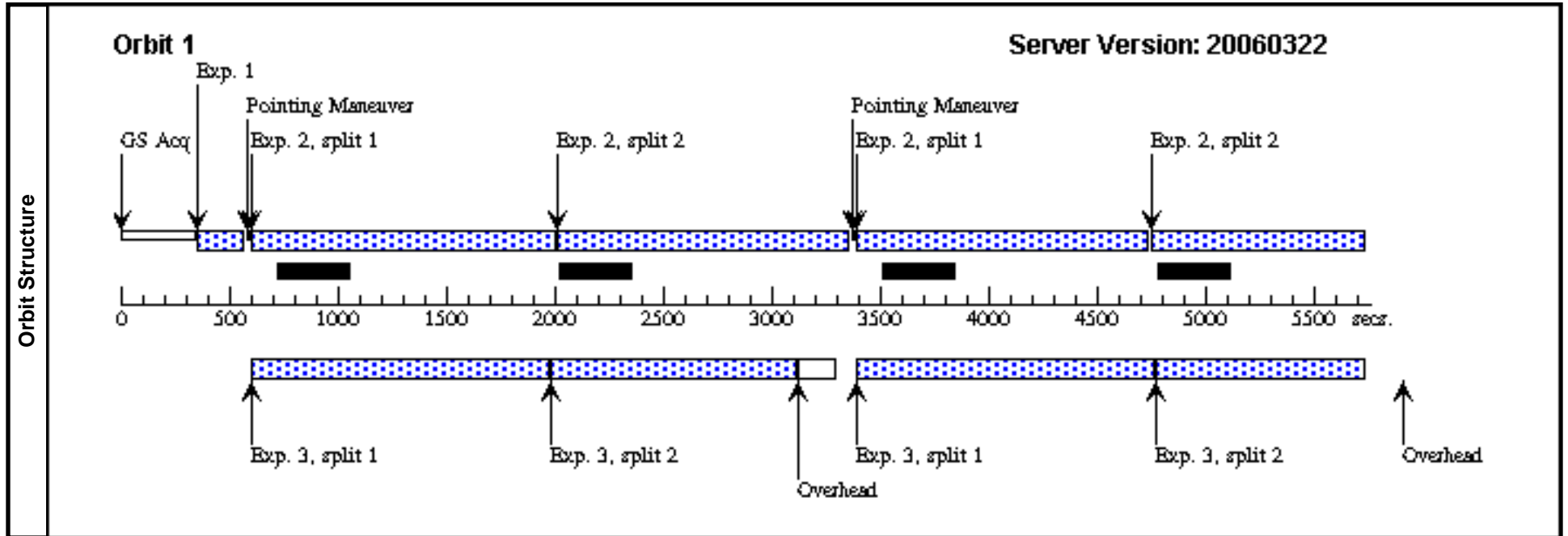

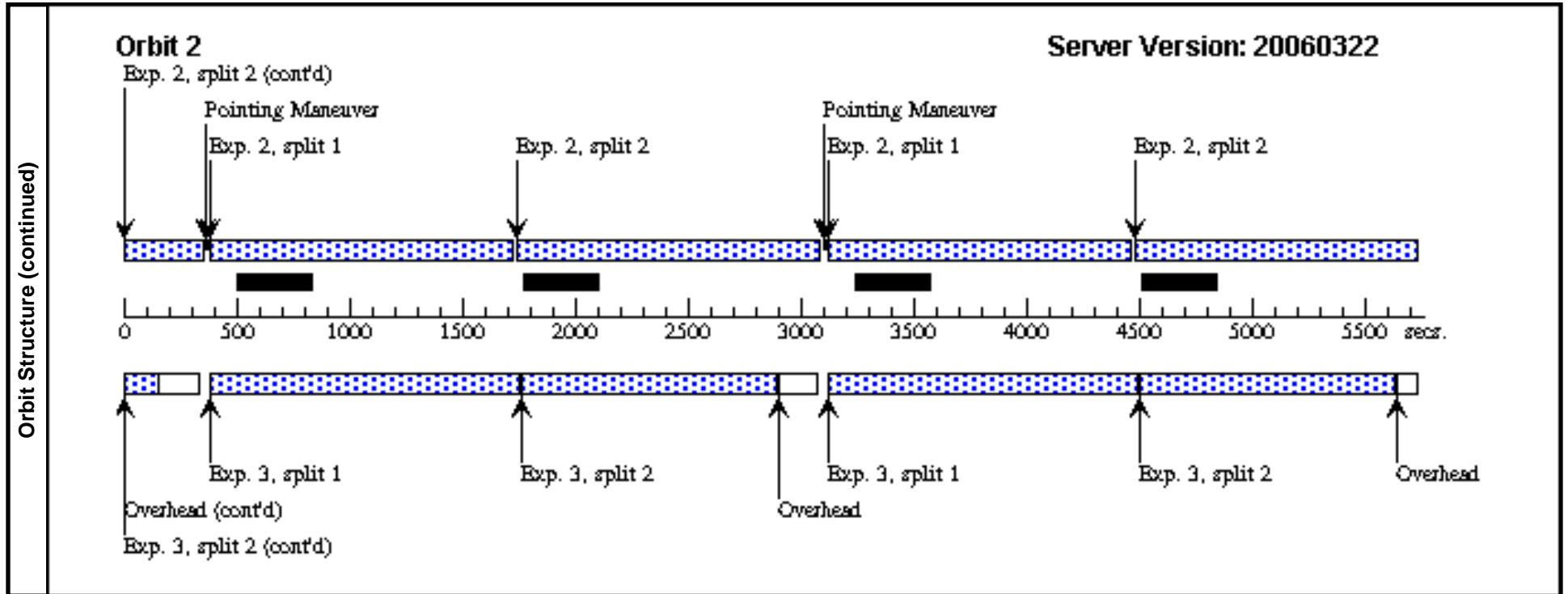

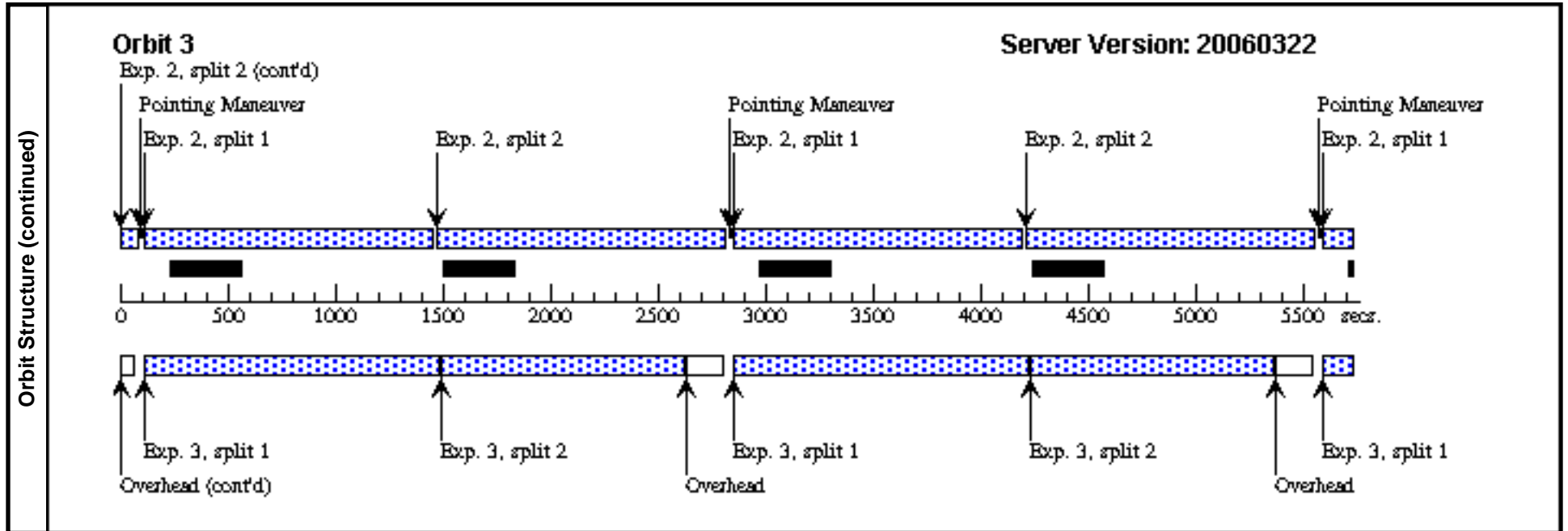

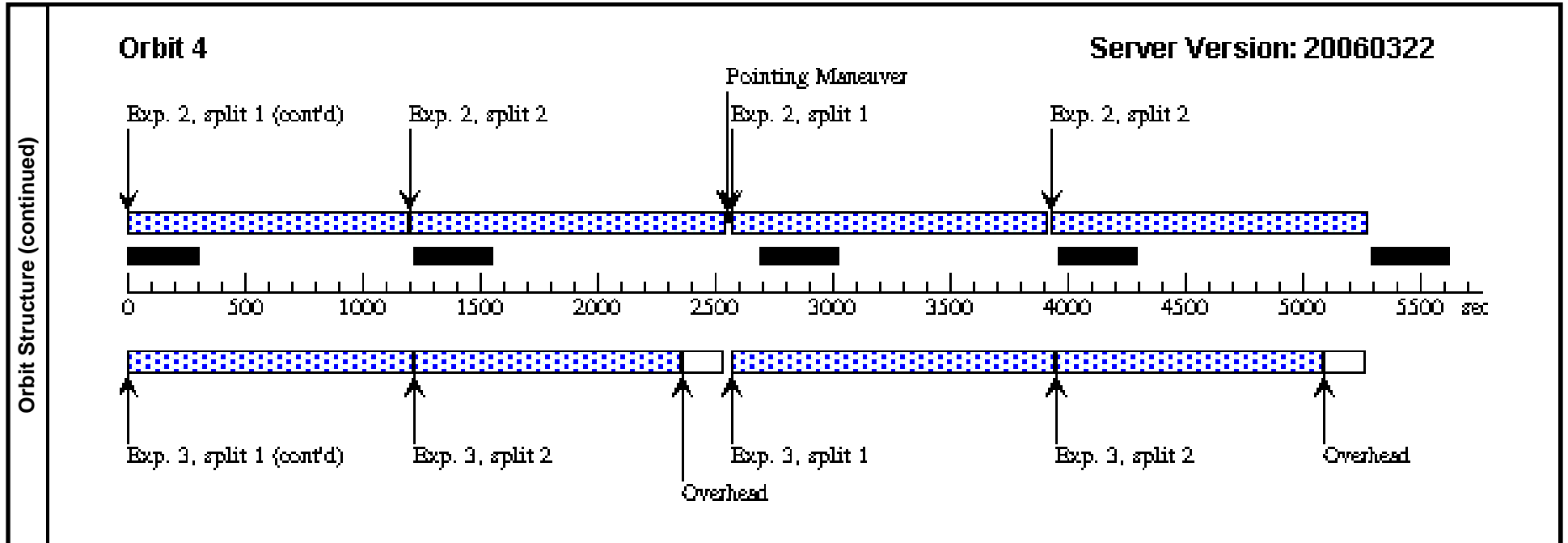

Proposal 10885 - Visit 03 - Deep Photometry of NGC 1569: Understanding the Closest and Strongest Starburst of the Nearby Universe

Wed Aug 02 02:49:38 GMT 2006

Visit	Proposal 10885, Visit 03 Diagnostic Status: Error Scientific Instruments: ACS/WFC, WFPC2 Special Requirements: CVZ; ORIENT 115.0D TO 115.0 D										
	Diagnostics	(WFPC2par (03.003)Pattern 2,3, Split 1) Error: Orbit number out of range (must be equal to 4 or 1 greater than that of the previous sub-exposure). To learn more about orbit numbers, please read the full error text in the Diagnostic Report.									
Patterns		#	Primary Pattern				Secondary Pattern				Exposures
	(1)	Pattern Type=ACS-WFC-DITHER-LINE Purpose=OTHER Number Of Points=2 Point Spacing=2.994 Line Spacing=	Coordinate Frame=POS-TARG Pattern Orientation=85.3 Angle Between Sides= Center Pattern=false	Pattern Type=ACS-WFC-DITHER-BOX Purpose=DITHER Number Of Points=4 Point Spacing=0.265 Line Spacing=0.187	Coordinate Frame=POS-TARG Pattern Orientation=20.7 Angle Between Sides=69.1 Center Pattern=false	(2-3)					
Fixed Targets	#	Name	Target Coordinates		Targ. Coord. Corrections		Fluxes	Miscellaneous			
	(1)	NGC1569	RA: 04 30 46.4052 (67.6933550d) Dec: +64 49 41.28 (64.82813d) Equinox: J2000				V=11.9	Reference Frame: ICRS			
<i>Comments: This object was generated by the targetselector and retrieved from the NED database.</i>											
Exposures	#	Label	Target	Config,Mode,Aperture	Spectral Els.	Opt. Params.	Special Reqs.	Groups	Exp. Time/[Actual Dur.]		Orbit
	1	ACSshort	(1) NGC1569	ACS/WFC, ACCUM, WFCENTER	F606W	CR-SPLIT=NO	POS TARG 0,0		3.0 Secs [==>]		[1]

Proposal 10885 - Visit 03 - Deep Photometry of NGC 1569: Understanding the Closest and Strongest Starburst of the Nearby Universe

#	Label	Target	Config,Mode,Aperture	Spectral Els.	Opt. Params.	Special Reqs.	Groups	Exp. Time/[Actual Dur.]	Orbit
Exposures (continued)	2	ACSprime	(1) NGC1569	ACS/WFC, ACCUM, WFCENTER	F606W	CR-SPLIT=2	Pattern 2-3 (1) Prime + Parallel Group 2-3	2446.0 Secs	
								[==>(Pattern 1,1, Split 1)]	[1]
								[==>(Pattern 1,1, Split 2)]	
								[==>(Pattern 1,2, Split 1)]	
								[==>(Pattern 1,2, Split 2)]	
								[==>(Pattern 1,3, Split 1)]	[2]
								[==>(Pattern 1,3, Split 2)]	
								[==>(Pattern 1,4, Split 1)]	
	[==>(Pattern 1,4, Split 2)]								
	[==>(Pattern 2,1, Split 1)]	[3]							
	[==>(Pattern 2,1, Split 2)]								
	[==>(Pattern 2,2, Split 1)]								
	[==>(Pattern 2,2, Split 2)]								
	[==>(Pattern 2,3, Split 1)]	[4]							
	[==>(Pattern 2,3, Split 2)]								
	[==>(Pattern 2,4, Split 1)]								
[==>(Pattern 2,4, Split 2)]									
3	WFPC2par	ANY	WFPC2, IMAGE, WFALL	F606W			Pattern 2-3 (1) Prime + Parallel Group 2-3	2200.0 Secs	
								[==>(Pattern 1,1, Split 1)]	[1]
								[==>(Pattern 1,1, Split 2)]	
								[==>(Pattern 1,2, Split 1)]	
								[==>(Pattern 1,2, Split 2)]	
								[==>(Pattern 1,3, Split 1)]	[2]
								[==>(Pattern 1,3, Split 2)]	
								[==>(Pattern 1,4, Split 1)]	
	[==>(Pattern 1,4, Split 2)]								
	[==>(Pattern 2,1, Split 1)]	[3]							
	[==>(Pattern 2,1, Split 2)]								
	[==>(Pattern 2,2, Split 1)]								
	[==>(Pattern 2,2, Split 2)]								
	[==>(Pattern 2,3, Split 1)]	[4]							
	[==>(Pattern 2,3, Split 2)]								
	[==>(Pattern 2,4, Split 1)]								
[==>(Pattern 2,4, Split 2)]									

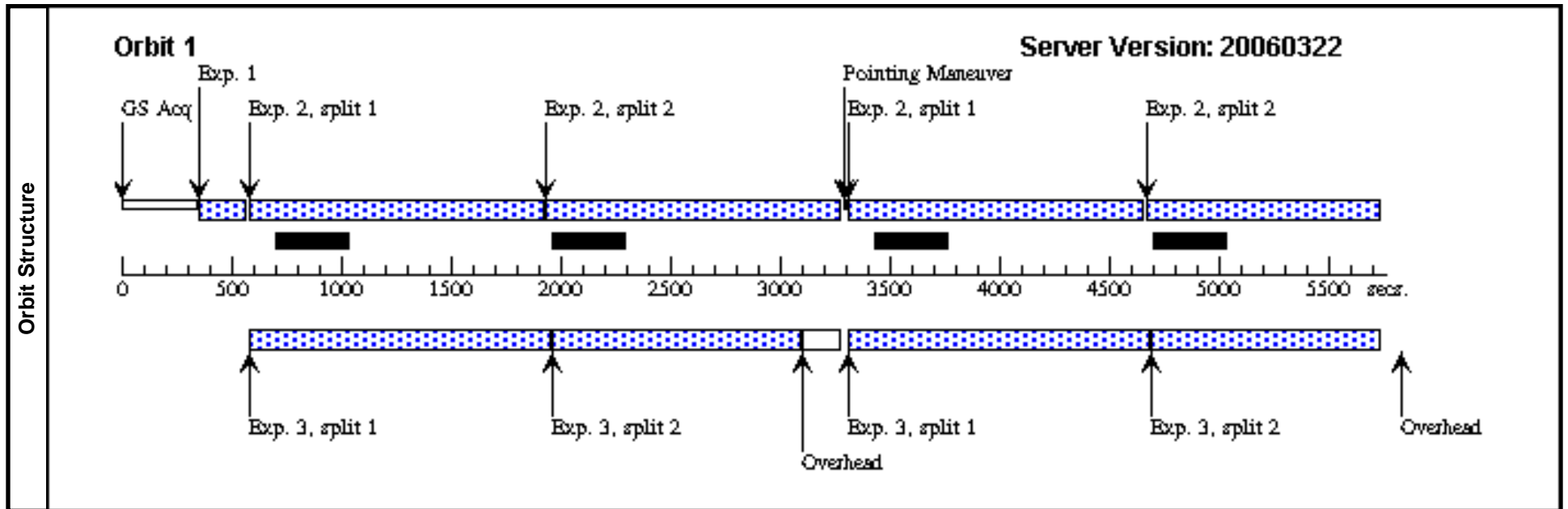

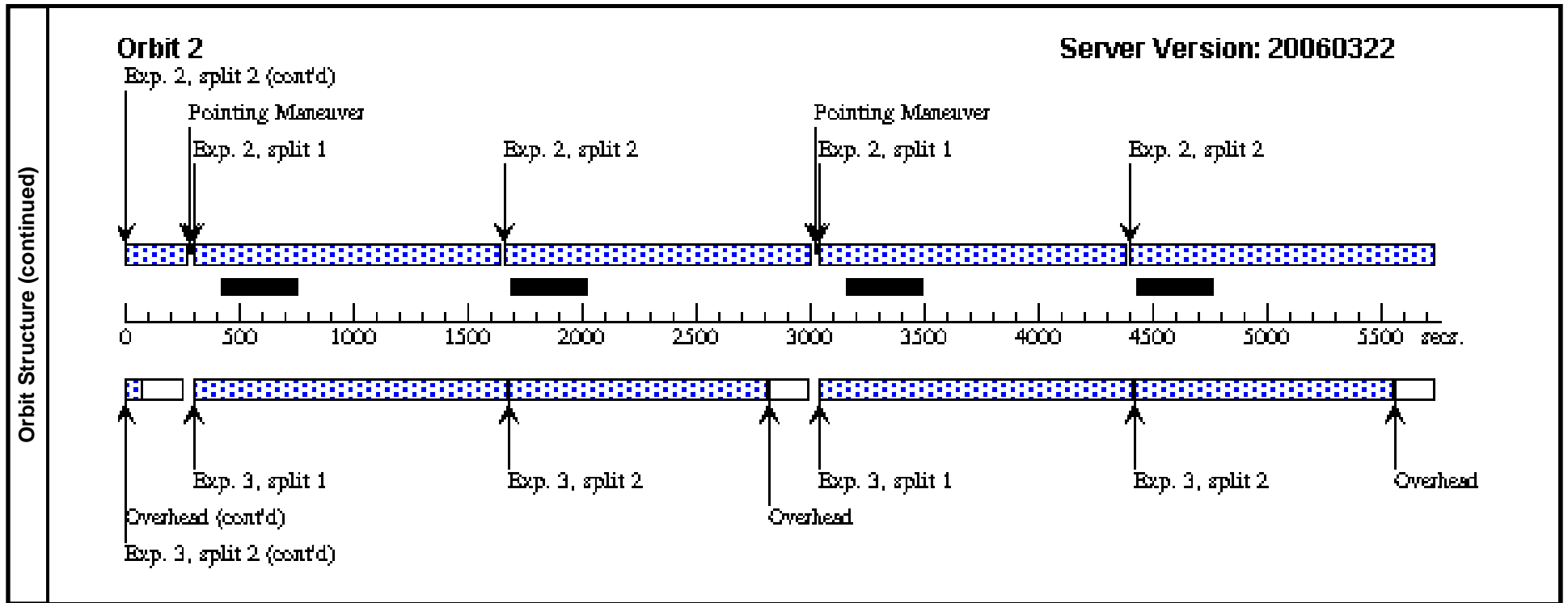

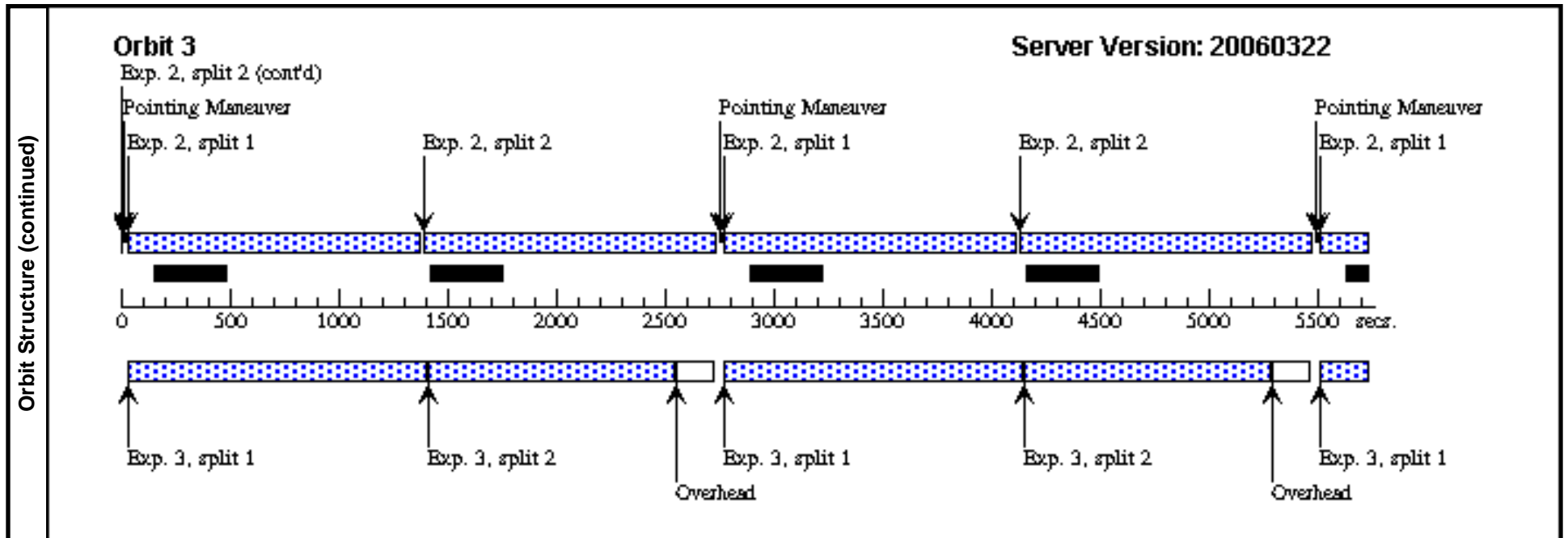

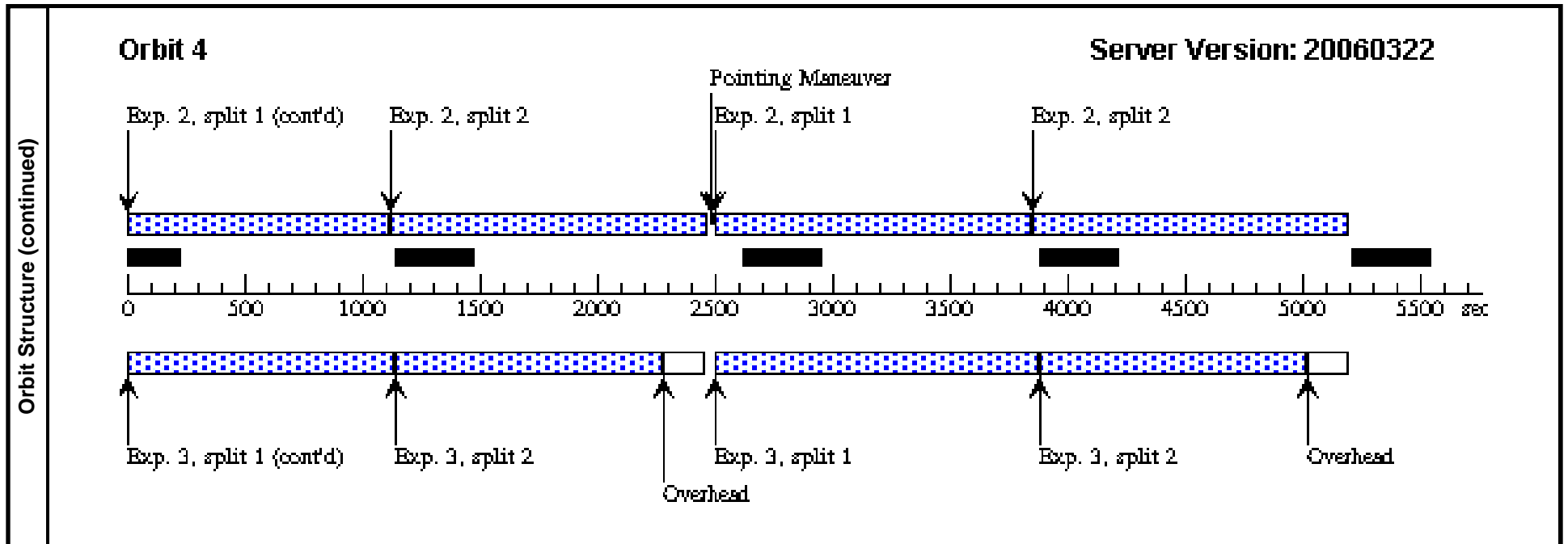

Proposal 10885 - Visit 04 - Deep Photometry of NGC 1569: Understanding the Closest and Strongest Starburst of the Nearby Universe

Wed Aug 02 02:49:39 GMT 2006

Visit		Proposal 10885, Visit 04 Diagnostic Status: No Diagnostics Scientific Instruments: ACS/WFC, WFPC2 Special Requirements: CVZ; ORIENT 205.0D TO 205.0 D								
Patterns	#	Primary Pattern		Secondary Pattern			Exposures			
	(4)	Pattern Type=ACS-WFC-DITHER-BOX Purpose=DITHER Number Of Points=4 Point Spacing=0.265 Line Spacing=0.187	Coordinate Frame=POS-TARG Pattern Orientation=20.7 Angle Between Sides=69.1 Center Pattern=false				(2-3)			
Fixed Targets	#	Name	Target Coordinates	Targ. Coord. Corrections	Fluxes	Miscellaneous				
	(1)	NGC1569	RA: 04 30 46.4052 (67.6933550d) Dec: +64 49 41.28 (64.82813d) Equinox: J2000 <i>Comments: This object was generated by the targetselector and retrieved from the NED database.</i>		V=11.9	Reference Frame: ICRS				
Exposures	#	Label	Target	Config,Mode,Aperture	Spectral Els.	Opt. Params.	Special Reqs.	Groups	Exp. Time/[Actual Dur.]	Orbit
	1	ACSshort	(1) NGC1569	ACS/WFC, ACCUM, WFCENTER	F606W	CR-SPLIT=NO	POS TARG 0.247,2.984		3.0 Secs	
									[==>]	[1]
	2	ACSprime	(1) NGC1569	ACS/WFC, ACCUM, WFCENTER	F606W	CR-SPLIT=2		Pattern 2-3 (4) Prime + Parallel Group 2-3	2345.0 Secs	
									[==>(Pattern 1, Split 1)] [==>(Pattern 1, Split 2)] [==>(Pattern 2, Split 1)] [==>(Pattern 2, Split 2)]	[1]
									[==>(Pattern 3, Split 1)] [==>(Pattern 3, Split 2)] [==>(Pattern 4, Split 1)] [==>(Pattern 4, Split 2)]	[2]
	3	WFPC2par	ANY	WFPC2, IMAGE, WFALL	F606W			Pattern 2-3 (4) Prime + Parallel Group 2-3	2000.0 Secs	
								[==>(Pattern 1, Split 1)] [==>(Pattern 1, Split 2)] [==>(Pattern 2, Split 1)] [==>(Pattern 2, Split 2)]	[1]	
								[==>(Pattern 3, Split 1)] [==>(Pattern 3, Split 2)] [==>(Pattern 4, Split 1)] [==>(Pattern 4, Split 2)]	[2]	

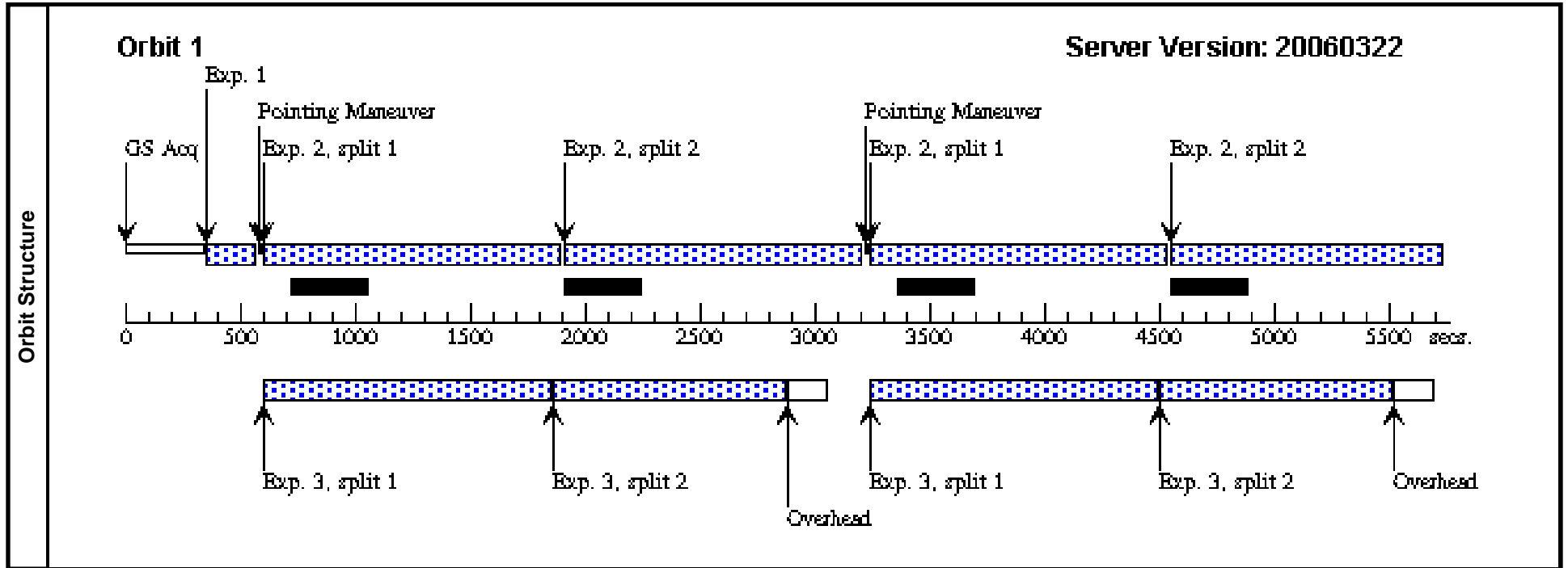

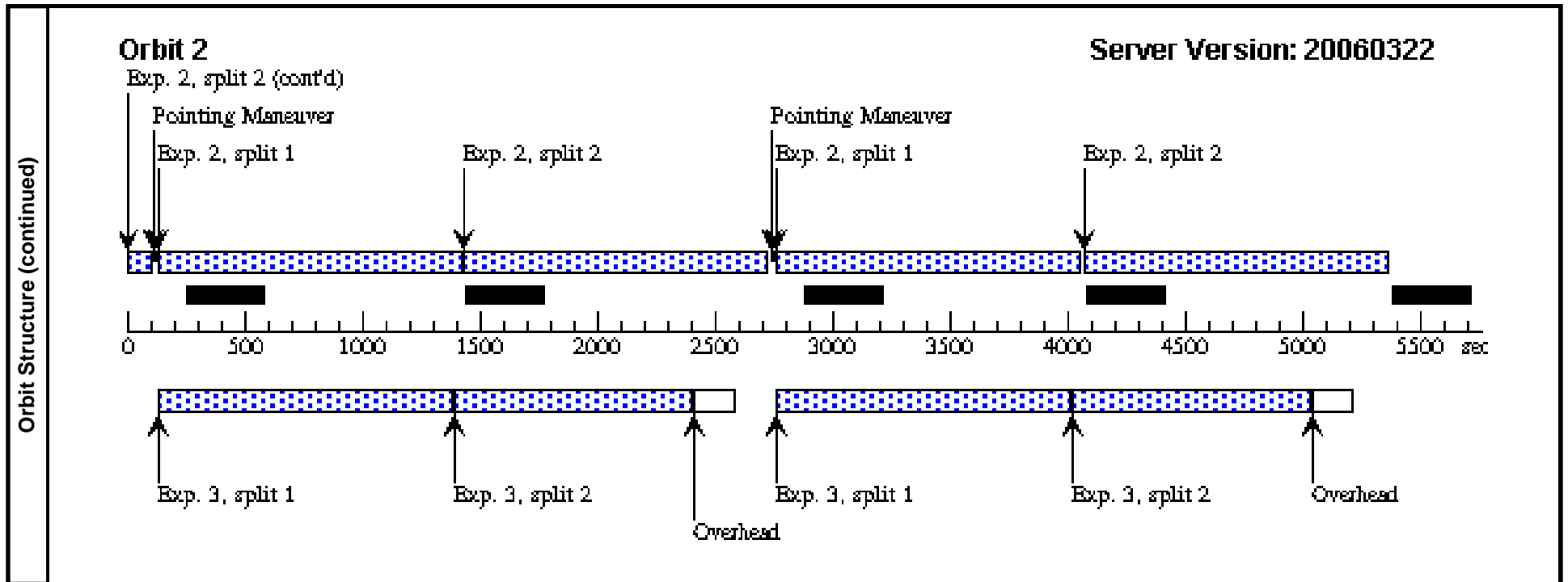

Proposal 10885 - Visit 05 - Deep Photometry of NGC 1569: Understanding the Closest and Strongest Starburst of the Nearby Universe

Wed Aug 02 02:49:40 GMT 2006

Visit	Proposal 10885, Visit 05 Diagnostic Status: No Diagnostics Scientific Instruments: ACS/WFC, WFPC2 Special Requirements: CVZ; ORIENT 205.0D TO 205.0 D									
	Patterns	#	Primary Pattern			Secondary Pattern			Exposures	
		(4)	Pattern Type=ACS-WFC-DITHER-BOX Purpose=DITHER Number Of Points=4 Point Spacing=0.265 Line Spacing=0.187	Coordinate Frame=POS-TARG Pattern Orientation=20.7 Angle Between Sides=69.1 Center Pattern=false					(1-2)	
Fixed Targets	#	Name	Target Coordinates	Targ. Coord. Corrections	Fluxes	Miscellaneous				
	(1)	NGC1569	RA: 04 30 46.4052 (67.6933550d) Dec: +64 49 41.28 (64.82813d) Equinox: J2000		V=11.9	Reference Frame: ICRS				
	<i>Comments: This object was generated by the targetselector and retrieved from the NED database.</i>									
Exposures	#	Label	Target	Config,Mode,Aperture	Spectral Els.	Opt. Params.	Special Reqs.	Groups	Exp. Time/[Actual Dur.]	Orbit
	1	ACSprime	(1) NGC1569	ACS/WFC, ACCUM, WFCENTER	F606W	CR-SPLIT=2	POS TARG 0.247,2.984	Pattern 1-2 (4) Prime + Parallel Group 1-2	2350.0 Secs [=>(Pattern 1, Split 1)] [=>(Pattern 1, Split 2)] [=>(Pattern 2, Split 1)] [=>(Pattern 2, Split 2)] [=>(Pattern 3, Split 1)] [=>(Pattern 3, Split 2)] [=>(Pattern 4, Split 1)] [=>(Pattern 4, Split 2)]	[1] [2]
	2	WFPC2par	ANY	WFPC2, IMAGE, WFALL	F606W			Pattern 1-2 (4) Prime + Parallel Group 1-2	2000.0 Secs [=>(Pattern 1, Split 1)] [=>(Pattern 1, Split 2)] [=>(Pattern 2, Split 1)] [=>(Pattern 2, Split 2)] [=>(Pattern 3, Split 1)] [=>(Pattern 3, Split 2)] [=>(Pattern 4, Split 1)] [=>(Pattern 4, Split 2)]	[1] [2]

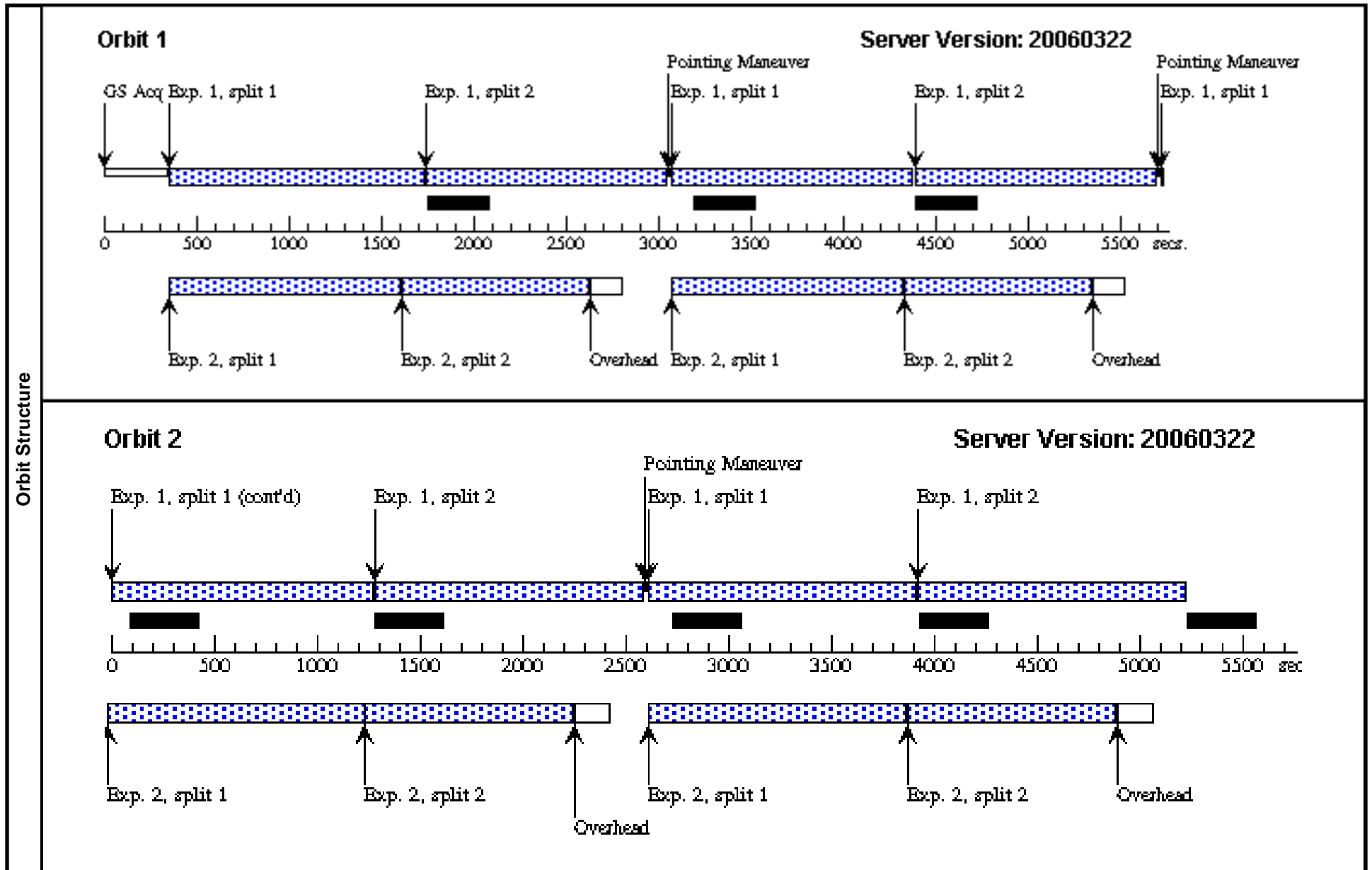

Proposal 10885 - Visit 06 - Deep Photometry of NGC 1569: Understanding the Closest and Strongest Starburst of the Nearby Universe

Wed Aug 02 02:49:41 GMT 2006

Visit	Proposal 10885, Visit 06 Diagnostic Status: No Diagnostics Scientific Instruments: ACS/WFC, WFPC2 Special Requirements: CVZ; ORIENT 115.0D TO 115.0 D									
	Patterns	#	Primary Pattern	Secondary Pattern	Exposures					
(2)		Pattern Type=ACS-WFC-DITHER-LINE Purpose=DITHER Number Of Points=2 Point Spacing=2.994 Line Spacing=	Coordinate Frame=POS-TARG Pattern Orientation=85.3 Angle Between Sides= Center Pattern=false		(1-3), (4-6)					
(3)		Pattern Type=ACS-WFC-DITHER-LINE Purpose=DITHER Number Of Points=2 Point Spacing=2.994 Line Spacing=	Coordinate Frame=POS-TARG Pattern Orientation=85.3 Angle Between Sides= Center Pattern=false	Pattern Type=ACS-WFC-DITHER-LINE Purpose=DITHER Number Of Points=2 Point Spacing=0.149 Line Spacing=	Coordinate Frame=POS-TARG Pattern Orientation=34.2 Angle Between Sides= Center Pattern=false	(7-8)				
Fixed Targets	#	Name	Target Coordinates	Targ. Coord. Corrections	Fluxes	Miscellaneous				
	(1)	NGC1569	RA: 04 30 46.4052 (67.6933550d) Dec: +64 49 41.28 (64.82813d) Equinox: J2000		V=11.9	Reference Frame: ICRS				
<i>Comments: This object was generated by the targetselector and retrieved from the NED database.</i>										
Exposures	#	Label	Target	Config,Mode,Aperture	Spectral Els.	Opt. Params.	Special Reqs.	Groups	Exp. Time/[Actual Dur.]	Orbit
	1	ACSprime	(1) NGC1569	ACS/WFC, ACCUM, WFCENTER	F606W	CR-SPLIT=NO		Pattern 1-3 (2) Prime + Parallel Group 1-3	180.0 Secs [==>(Pattern 1)] [==>(Pattern 2)]	[1]
	2	ACSprime	(1) NGC1569	ACS/WFC, ACCUM, WFCENTER	F606W	CR-SPLIT=2		Pattern 1-3 (2) Prime + Parallel Group 1-3	1720.0 Secs [==>(Pattern 1, Split 1)] [==>(Pattern 1, Split 2)] [==>(Pattern 2, Split 1)] [==>(Pattern 2, Split 2)]	[1]
	3	WFPC2par	ANY	WFPC2, IMAGE, WFALL	F606W			Pattern 1-3 (2) Prime + Parallel Group 1-3	1800.0 Secs [==>(Pattern 1, Split 1)] [==>(Pattern 1, Split 2)] [==>(Pattern 2, Split 1)] [==>(Pattern 2, Split 2)]	[1]

Proposal 10885 - Visit 06 - Deep Photometry of NGC 1569: Understanding the Closest and Strongest Starburst of the Nearby Universe

#	Label	Target	Config,Mode,Aperture	Spectral Els.	Opt. Params.	Special Reqs.	Groups	Exp. Time/[Actual Dur.]	Orbit
Exposures (continued)	4	ACSprime	(1) NGC1569	ACS/WFC, ACCUM, WFCENTER	F814W	CR-SPLIT=NO	Pattern 4-6 (2) Prime + Parallel Group 4-6	180.0 Secs [==>(Pattern 1)] [==>(Pattern 2)]	[2]
	5	ACSprime	(1) NGC1569	ACS/WFC, ACCUM, WFCENTER	F814W	CR-SPLIT=2	Pattern 4-6 (2) Prime + Parallel Group 4-6	2080.0 Secs [==>(Pattern 1, Split 1)] [==>(Pattern 1, Split 2)] [==>(Pattern 2, Split 1)] [==>(Pattern 2, Split 2)]	[2]
	6	WFPC2par	ANY	WFPC2, IMAGE, WFALL	F606W		Pattern 4-6 (2) Prime + Parallel Group 4-6	2200.0 Secs [==>(Pattern 1, Split 1)] [==>(Pattern 1, Split 2)] [==>(Pattern 2, Split 1)] [==>(Pattern 2, Split 2)]	[2]
	7	ACSprime	(1) NGC1569	ACS/WFC, ACCUM, WFCENTER	F658N	CR-SPLIT=NO	Pattern 7-8 (3) Prime + Parallel Group 7-8	1155.0 Secs [==>(Pattern 1,1)] [==>(Pattern 1,2)] [==>(Pattern 2,1)] [==>(Pattern 2,2)]	[3]
	8	WFPC2par	ANY	WFPC2, IMAGE, WFALL	F814W	CR-SPLIT=NO	Pattern 7-8 (3) Prime + Parallel Group 7-8	1000.0 Secs [==>(Pattern 1,1)] [==>(Pattern 1,2)] [==>(Pattern 2,1)] [==>(Pattern 2,2)]	[3]

