



## 10916 - A Study of SN Ejecta in the Core-Collapse Supernova Remnant G292.0+1.8: Cas A's Older Cousin

Cycle: 15, Proposal Category: GO

(Availability Mode: SUPPORTED)

### INVESTIGATORS

<i>Name</i>	<i>Institution</i>	<i>E-Mail</i>
<b>Dr. Robert A. Fesen (PI)</b>	<b>Dartmouth College</b>	<b>fesen@snr.dartmouth.edu</b>
Dr. P. Frank Winkler (CoI)	Middlebury College	winkler@middlebury.edu
Dr. William P. Blair (CoI)	The Johns Hopkins University	wpb@pha.jhu.edu
Dr. John P. Hughes (CoI)	Rutgers the State University of New Jersey	jph@physics.rutgers.edu
Dr. Parviz Ghavamian (CoI)	The Johns Hopkins University	parviz@pha.jhu.edu
Dr. Knox S. Long (CoI)	Space Telescope Science Institute	long@stsci.edu

### VISITS

<i>Visit</i>	<i>Targets used in Visit</i>	<i>Configurations used in Visit</i>	<i>Orbits Used</i>	<i>Last Orbit Planner Run</i>	<i>OP Current with Visit?</i>
01	(1) G292-NORTH-WEST (2) G292-NORTH-EAST (3) G292-WEST-CENTRAL (5) G292-CENTRAL	WFPC2	4	13-Mar-2008 21:00:54.0	yes
02	(4) G292-EAST-CENTRAL (6) G292-SOUTH-WEST (7) G292-SOUTH-CENTRAL (8) G292-SOUTH-EAST	WFPC2	4	13-Mar-2008 21:01:09.0	yes

<i>Visit</i>	<i>Targets used in Visit</i>	<i>Configurations used in Visit</i>	<i>Orbits Used</i>	<i>Last Orbit Planner Run</i>	<i>OP Current with Visit?</i>
03	(9) G292-EAST-CENTRAL-B (10) G292-CENTER-B (11) G292-NORTH-CENTER-B	WFPC2	4	13-Mar-2008 21:01:20.0	yes

12 Total Orbits Used

### **ABSTRACT**

Recent studies of the southern oxygen-rich supernova remnant (SNR) G292.0+1.8 have shown it to be the only Galactic SNR to exhibit all the features we expect in young remnants of core-collapse supernovae: an outer shell behind an expanding primary shock, high-velocity fragments of undiluted metal-rich ejecta, and a central pulsar surrounded by a pulsar-wind nebula. G292.0+1.8's optical emission consists of numerous knots and filaments of O- and S-rich ejecta spread throughout much of the remnant shell, many with radially oriented pencil-like geometries that may trace their origins to Rayleigh-Taylor instabilities during the SN event.

The evolution and fine-scale structure of SN debris in young remnants is poorly understood and largely uncharted territory. For testing models for the distribution of metal-rich ejecta from core-collapse SNe, how the ejecta evolve and clump, and how SN shocks interact with the local circumstellar medium, the 3000-yr-old G292.0+1.8 remnant rivals the 320-yr-old Cas A remnant in importance. We therefore propose the first HST images of G292.0+1.8 in order to characterize the fine-scale spatial distribution of the ejecta, their sub-arcsecond chemical make-up, and the detailed structure and scale lengths for metal-rich SN ejecta clumps.

The proposed HST images of G292.0+1.8 will be used in conjunction with existing Spitzer Cycle 1 infrared data and an upcoming 0.5 Msec Chandra X-ray image. We expect to achieve the same kind of results for G292 that have already been obtained for Cas A. High-resolution HST images of this remnant, combined with Spitzer and Chandra data and contrasted with a similar data set on Cas A, will provide superb multiwavelength benchmarks for both very young and older core-collapse SNRs.

## **OBSERVING DESCRIPTION**

This project is to image all of the known optical emission associated with the southern hemisphere SNR G292.0-1.8 using the [O III] 5007 sensitive filter F475W (broad enough to detect all the object's high velocity ejecta) along with F550M filter images to serve as continuum background image for subtraction. We will take images at six target regions to create a mosaic image of the whole object.

In addition, we will take images at two other target locations in the remnant using the F625W and F850LP filters; one to the north and the other along the central eastern limb. In Phase I, we had thought that the eastern limb position used for creating the 2 x 6 image mosaic would work for the F625W and F850LP images, but after some more thought, it was decided to add a 8th target position that was slightly different from that of the G292-East-Central location. We call this spot the g292-East-Central-2. It differs only a bit from the G292-East-Central location but does a better job of imaging the remnant's H $\alpha$  emission structure here as seen on ground-based images.

Since the supernova remnant lies inside the CVZ, we use these much longer orbits to take these images. The procedure of for taking the images is simple. Two sets of images dithered by the standard offset positioning to cover the chip gap.

## **ADDITIONAL COMMENTS**

Note: We have added an 8th target position (see obs. descrip. above). The Phase I Proposal did describe our intention of taking data at 8 positions, However, at the time of proposal submission, we thought we could just use one of the 6 mosaic positions for the last 8th set of images. However, after we examined the positioning of this location onto the remnant's H $\alpha$  emission structure, it was decided to specifically include an 8th target location that was close to but importantly different from the East-Central positioning so

as to maximize the science return as much as possible.

Proposal 10916 - Visit 01 - A Study of SN Ejecta in the Core-Collapse Supernova Remnant G292.0+1.8: Cas A's Older Cou...

Fri Mar 14 01:01:26 GMT 2008

Visit		<b>Proposal 10916, Visit 01, failed</b> <b>Diagnostic Status: No Diagnostics</b> Scientific Instruments: WFPC2 Special Requirements: CVZ; ORIENT 135.0D TO 135.5 D; BETWEEN 30-JUN-2007:00:00:00 AND 15-JUL-2007:20:00:00								
Patterns	#	Primary Pattern		Secondary Pattern			Exposures			
	(1)	Pattern Type=WFPC2-BOX Purpose=DITHER Number Of Points=4 Point Spacing=0.559017 Line Spacing=0.559017	Coordinate Frame=POS-TARG Pattern Orientation=26.56505 Angle Between Sides=143.1301 Center Pattern=false				(1), (2), (3-4), (5)			
Fixed Targets	#	Name	Target Coordinates	Targ. Coord. Corrections	Fluxes	Miscellaneous				
	(1)	G292-NORTH-WEST	RA: 11 24 36.0000 (171.1500000d) Dec: -59 13 40.00 (-59.22778d) Equinox: J2000		V=20	Reference Frame: ICRS				
	(2)	G292-NORTH-EAST	RA: 11 24 50.1000 (171.2087500d) Dec: -59 14 57.00 (-59.24917d) Equinox: J2000		V=20	Reference Frame: ICRS				
	(3)	G292-WEST-CENTRAL	RA: 11 24 31.4000 (171.1308333d) Dec: -59 16 2.00 (-59.26722d) Equinox: J2000		V=20	Reference Frame: ICRS				
	(5)	G292-CENTRAL	RA: 11 24 40.8600 (171.1702500d) Dec: -59 16 2.00 (-59.26722d) Equinox: J2000		V=20	Reference Frame: ICRS				
Exposures	#	Label	Target	Config,Mode,Aperture	Spectral Els.	Opt. Params.	Special Reqs.	Groups	Exp. Time/[Actual Dur.]	Orbit
	1		(1) G292-NORTH-WEST	WFPC2, IMAGE, WF3-FIX	F450W	CR-SPLIT=NO		Pattern 1-1 (1)	800.0 Secs [=>(Pattern 1)] [=>(Pattern 2)] [=>(Pattern 3)] [=>(Pattern 4)]	[1]
	2		(3) G292-WEST-CENTRAL	WFPC2, IMAGE, WF3-FIX	F450W	CR-SPLIT=NO		Pattern 2-2 (1)	800.0 Secs [=>(Pattern 1)] [=>(Pattern 2)] [=>(Pattern 3)] [=>(Pattern 4)]	[1] [2]
	3		(5) G292-CENTRAL	WFPC2, IMAGE, WF3-FIX	F450W	CR-SPLIT=NO		Pattern 3-4 (1)	800.0 Secs [=>(Pattern 1)] [=>(Pattern 2)] [=>(Pattern 3)] [=>(Pattern 4)]	[2] [3]

Proposal 10916 - Visit 01 - A Study of SN Ejecta in the Core-Collapse Supernova Remnant G292.0+1.8: Cas A's Older Cou...

Exposures (continued)	#	Label	Target	Config, Mode, Aperture	Spectral Els.	Opt. Params.	Special Reqs.	Groups	Exp. Time/[Actual Dur.]	Orbit
	4	(5) G292-CENTRAL	WFPC2, IMAGE, WF3-FIX	F675W			Pattern 3-4 (1)	500.0 Secs	[2]	
							[=>(Pattern 1)]	[3]		
							[=>(Pattern 2)]	[3]		
							[=>(Pattern 3)]	[3]		
							[=>(Pattern 4)]	[3]		
5	(2) G292-NORTH-E AST	WFPC2, IMAGE, WF3-FIX	F450W	CR-SPLIT=NO		Pattern 5-5 (1)	800.0 Secs	[4]		
							[=>(Pattern 1)]	[4]		
							[=>(Pattern 2)]	[4]		
							[=>(Pattern 3)]	[4]		
							[=>(Pattern 4)]	[4]		

Orbit Structure

**Orbit 1** Server Version: 20071214

Orbit Structure

**Orbit 2** Server Version: 20071214

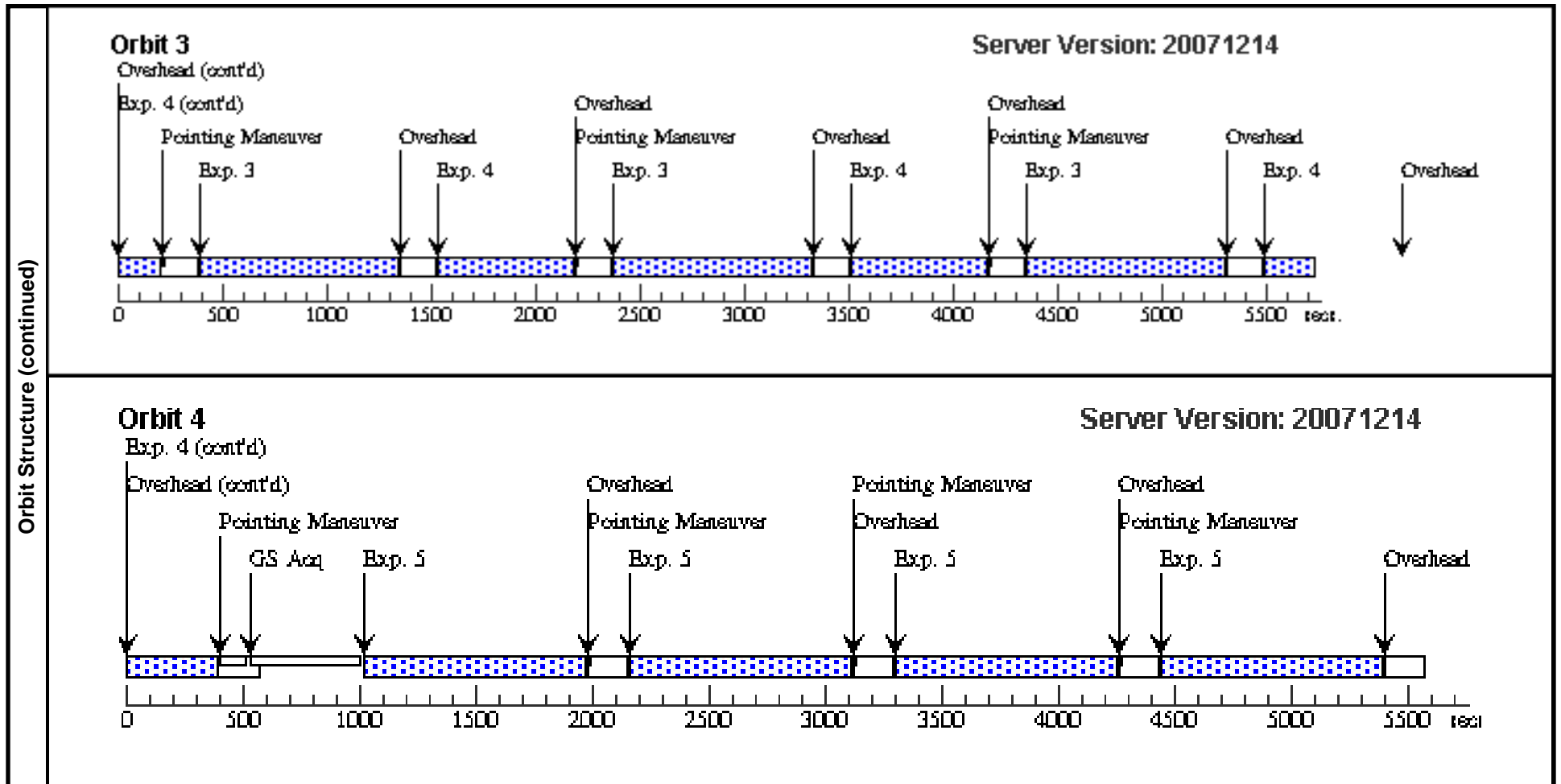

Proposal 10916 - Visit 02 - A Study of SN Ejecta in the Core-Collapse Supernova Remnant G292.0+1.8: Cas A's Older Cou...

Fri Mar 14 01:01:28 GMT 2008

Visit	<b>Proposal 10916, Visit 02, completed</b> <b>Diagnostic Status: No Diagnostics</b> Scientific Instruments: WFPC2 Special Requirements: CVZ; ORIENT 135.0D TO 135.5 D; BETWEEN 30-JUN-2007:00:00:00 AND 15-JUL-2007:00:00:00									
	Patterns	#	Primary Pattern			Secondary Pattern			Exposures	
		(1)	Pattern Type=WFPC2-BOX Purpose=DITHER Number Of Points=4 Point Spacing=0.559017 Line Spacing=0.559017	Coordinate Frame=POS-TARG Pattern Orientation=26.56505 Angle Between Sides=143.1301 Center Pattern=false					(1-2), (3), (4), (5)	
Fixed Targets	#	Name	Target Coordinates	Targ. Coord. Corrections	Fluxes	Miscellaneous				
	(4)	G292-EAST-CENTRAL	RA: 11 24 50.3100 (171.2096250d) Dec: -59 17 12.30 (-59.28675d) Equinox: J2000		V=20	Reference Frame: ICRS				
	(6)	G292-SOUTH-WEST	RA: 11 24 27.6600 (171.1152500d) Dec: -59 18 31.70 (-59.30881d) Equinox: J2000		V=20	Reference Frame: ICRS				
	(7)	G292-SOUTH-CENTRAL	RA: 11 24 29.0000 (171.1208333d) Dec: -59 20 24.40 (-59.34011d) Equinox: J2000		V=20	Reference Frame: ICRS				
	(8)	G292-SOUTH-EAST	RA: 11 24 43.6000 (171.1816667d) Dec: -59 19 33.00 (-59.32583d) Equinox: J2000		V=20	Reference Frame: ICRS				
Exposures	#	Label	Target	Config,Mode,Aperture	Spectral Els.	Opt. Params.	Special Reqs.	Groups	Exp. Time/[Actual Dur.]	Orbit
	1		(4) G292-EAST-CE NTRAL	WFPC2, IMAGE, WF3-FIX	F450W	CR-SPLIT=NO		Pattern 1-2 (1)	800.0 Secs	
									[==>(Pattern 1)]	
									[==>(Pattern 2)]	[1]
									[==>(Pattern 3)]	
									[==>(Pattern 4)]	[2]
	2		(4) G292-EAST-CE NTRAL	WFPC2, IMAGE, WF3-FIX	F675W	CR-SPLIT=NO		Pattern 1-2 (1)	500.0 Secs	
									[==>(Pattern 1)]	
									[==>(Pattern 2)]	[1]
									[==>(Pattern 3)]	
									[==>(Pattern 4)]	[2]
	3		(8) G292-SOUTH-E AST	WFPC2, IMAGE, WF3-FIX	F450W	CR-SPLIT=NO		Pattern 3-3 (1)	800.0 Secs	
								[==>(Pattern 1)]		
								[==>(Pattern 2)]	[2]	
								[==>(Pattern 3)]		
								[==>(Pattern 4)]	[3]	

Proposal 10916 - Visit 02 - A Study of SN Ejecta in the Core-Collapse Supernova Remnant G292.0+1.8: Cas A's Older Cou...

Exposures (continued)	#	Label	Target	Config,Mode,Aperture	Spectral Els.	Opt. Params.	Special Reqs.	Groups	Exp. Time/[Actual Dur.]	Orbit
	4	(7) G292-SOUTH-C ENTRAL	WFPC2, IMAGE, WF3-FIX	F450W	CR-SPLIT=NO	Pattern 4-4 (1)	800.0 Secs [=>(Pattern 1)] [=>(Pattern 2)] [=>(Pattern 3)] [=>(Pattern 4)]	[3]		
5	(6) G292-SOUTH-W EST	WFPC2, IMAGE, WF3-FIX	F450W	CR-SPLIT=NO	Pattern 5-5 (1)	800.0 Secs [=>(Pattern 1)] [=>(Pattern 2)] [=>(Pattern 3)] [=>(Pattern 4)]	[4]			

Orbit Structure	Orbit 1	Server Version: 20071214
	<p>The diagram for Orbit 1 shows a sequence of events over a 5500-second period. It starts with 'GS Acq' at 0s, followed by 'Exp. 1' at approximately 300s. This is followed by a series of alternating 'Overhead' and 'Exp.' blocks. 'Exp. 1' blocks occur at approximately 1300s, 2300s, 3300s, and 4300s. 'Exp. 2' blocks occur at approximately 1500s, 3500s, and 5300s. 'Pointing Maneuver' events are indicated at approximately 2100s, 3800s, and 4800s. The timeline ends with an 'Overhead' block at approximately 5700s.</p>	

Orbit Structure	Orbit 2	Server Version: 20071214
	<p>The diagram for Orbit 2 shows a sequence of events over a 5500-second period. It begins with 'Exp. 2 (cont'd)' at 0s, followed by 'Overhead (cont'd)'. 'Exp. 1' occurs at approximately 400s. 'Overhead' blocks are present at approximately 1400s, 2400s, 3400s, and 4400s. 'Pointing Maneuver' events occur at approximately 1600s, 2600s, 3600s, and 4600s. 'Exp. 2' occurs at approximately 1700s. 'GS Acq' is at approximately 2500s, followed by 'Exp. 3' at approximately 2900s. 'Exp. 3' also occurs at approximately 4100s and 5100s. The timeline ends with an 'Overhead' block at approximately 5700s.</p>	

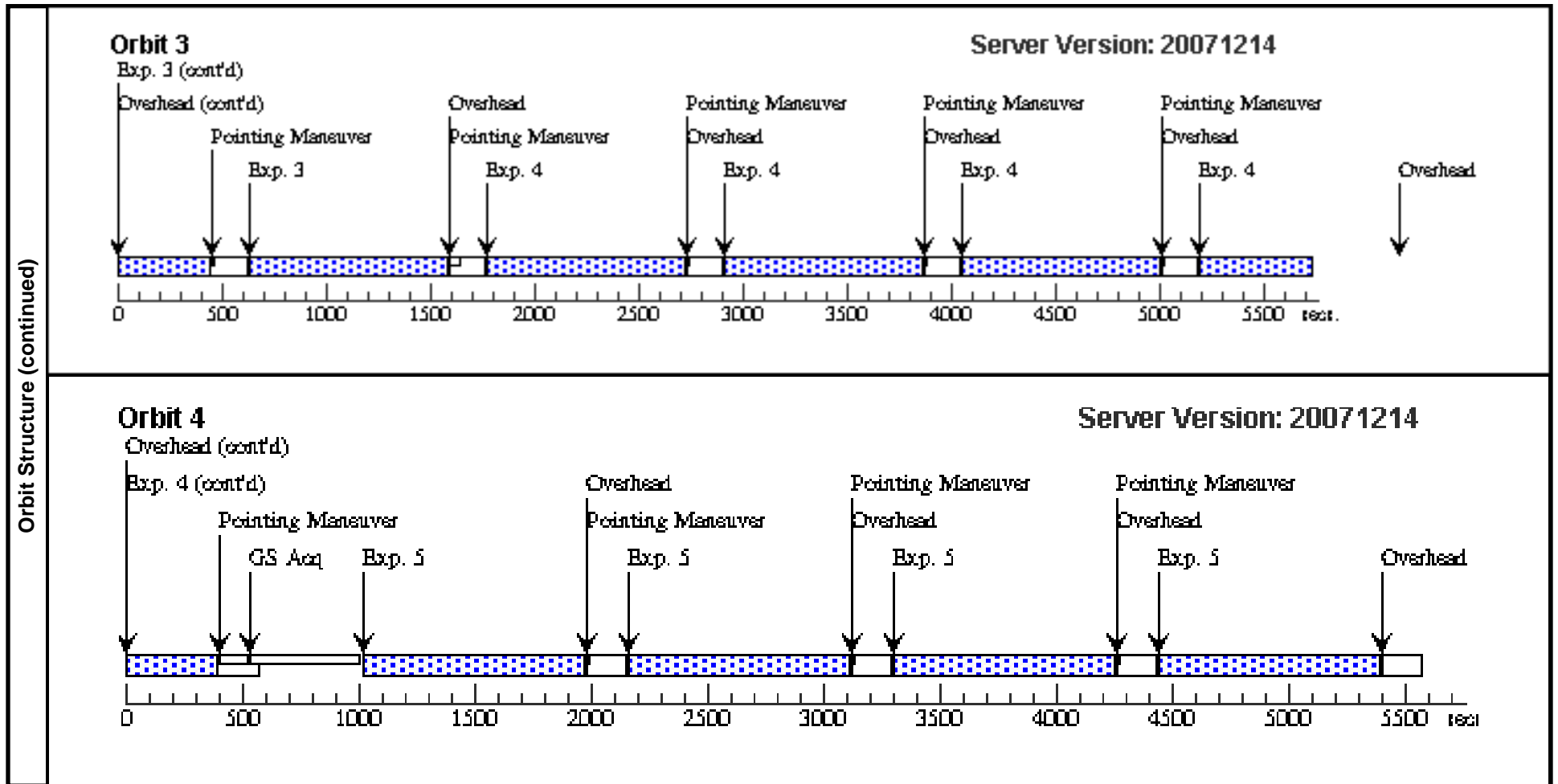

Proposal 10916 - Visit 03 - A Study of SN Ejecta in the Core-Collapse Supernova Remnant G292.0+1.8: Cas A's Older Cou...

Fri Mar 14 01:01:29 GMT 2008

Visit	<b>Proposal 10916, Visit 03, pi</b> <b>Diagnostic Status: No Diagnostics</b> Scientific Instruments: WFPC2 Special Requirements: CVZ; ORIENT 44.5D TO 45.5 D; BETWEEN 01-APR-2008:00:00:00 AND 01-MAY-2008:00:00:00									
	Patterns	#	Primary Pattern				Secondary Pattern			Exposures
		(1)	Pattern Type=WFPC2-BOX Purpose=DITHER Number Of Points=4 Point Spacing=0.559017 Line Spacing=0.559017	Coordinate Frame=POS-TARG Pattern Orientation=26.56505 Angle Between Sides=143.1301 Center Pattern=false						(1-2), (3-4), (5-7)
Fixed Targets	#	Name	Target Coordinates	Targ. Coord. Corrections	Fluxes	Miscellaneous				
	(9)	G292-EAST-CENTRAL-B	RA: 11 24 42.2380 (171.1759917d) Dec: -59 14 46.37 (-59.24621d) Equinox: J2000		V=21+/-3	Reference Frame: ICRS				
	(10)	G292-CENTER-B	RA: 11 24 38.1750 (171.1590625d) Dec: -59 15 59.00 (-59.26639d) Equinox: J2000		V=24+/-2	Reference Frame: ICRS				
	(11)	G292-NORTH-CENTER-B	RA: 11 24 31.2860 (171.1303583d) Dec: -59 12 34.80 (-59.20967d) Equinox: J2000		V=21+/-3	Reference Frame: ICRS				
Exposures	#	Label	Target	Config,Mode,Aperture	Spectral Els.	Opt. Params.	Special Reqs.	Groups	Exp. Time/[Actual Dur.]	Orbit
	1		(9) G292-EAST-CE NTRAL-B	WFPC2, IMAGE, WF3-FIX	F450W	CR-SPLIT=NO		Pattern 1-2 (1)	600.0 Secs [=>(Pattern 1)] [=>(Pattern 2)] [=>(Pattern 3)] [=>(Pattern 4)]	[1]
	2		(9) G292-EAST-CE NTRAL-B	WFPC2, IMAGE, WF3-FIX	F547M			Pattern 1-2 (1)	400.0 Secs [=>(Pattern 1)] [=>(Pattern 2)] [=>(Pattern 3)] [=>(Pattern 4)]	[1] [2]
	3		(10) G292-CENTER -B	WFPC2, IMAGE, WF3-FIX	F547M	CR-SPLIT=NO		Pattern 3-4 (1)	400.0 Secs [=>(Pattern 1)] [=>(Pattern 2)] [=>(Pattern 3)] [=>(Pattern 4)]	[2]

#	Label	Target	Config,Mode,Aperture	Spectral Els.	Opt. Params.	Special Reqs.	Groups	Exp. Time/[Actual Dur.]	Orbit
Exposures (continued)	4	(10) G292-CENTER-B	WFPC2, IMAGE, WF3-FIX	F675W	CR-SPLIT=NO		Pattern 3-4 (1)	600.0 Secs	
								[==>(Pattern 1)]	[2]
								[==>(Pattern 2)]	
								[==>(Pattern 3)]	[3]
	5	(11) G292-NORTH-CENTER-B	WFPC2, IMAGE, WF3-FIX	F450W	CR-SPLIT=NO		Pattern 5-7 (1)	600.0 Secs	
								[==>(Pattern 1)]	[3]
								[==>(Pattern 2)]	
								[==>(Pattern 3)]	[4]
	6	(11) G292-NORTH-CENTER-B	WFPC2, IMAGE, WF3-FIX	F675W	CR-SPLIT=NO		Pattern 5-7 (1)	500.0 Secs	
								[==>(Pattern 1)]	[3]
								[==>(Pattern 2)]	
								[==>(Pattern 3)]	[4]
7	(11) G292-NORTH-CENTER-B	WFPC2, IMAGE, WF3-FIX	F547M			Pattern 5-7 (1)	400.0 Secs		
							[==>(Pattern 1)]	[3]	
							[==>(Pattern 2)]		
							[==>(Pattern 3)]	[4]	
Orbit Structure	<p><b>Orbit 1</b> <span style="float: right;"><b>Server Version: 20071214</b></span></p> <p>The diagram illustrates the sequence of events for Orbit 1. It features a horizontal timeline from 0 to 5500 seconds. A blue checkered bar at the bottom represents the active observation period. Key events are marked with vertical arrows: 'GS Acq' at 0s, 'Exp. 1' at ~30s, 'Exp. 2' at ~120s, 'Pointing Maneuver' at ~170s, 'Exp. 1' at ~180s, 'Exp. 2' at ~280s, 'Pointing Maneuver' at ~330s, 'Exp. 1' at ~340s, 'Exp. 2' at ~440s, 'Pointing Maneuver' at ~490s, and 'Exp. 1' at ~500s. 'Overhead' periods are indicated between the pointing maneuvers.</p>								

