



11136 - Resolving Ultracool Astrophysics with Brown Dwarf Binaries

Cycle: 16, Proposal Category: GO

(Availability Mode: SUPPORTED)

INVESTIGATORS

<i>Name</i>	<i>Institution</i>	<i>E-Mail</i>
Dr. Michael C. Liu (PI)	University of Hawaii	mliu@ifa.hawaii.edu
Dr. Michael Cushing (CoI)	University of Arizona	mcushing@as.arizona.edu
Dr. Adam J. Burgasser (CoI)	Massachusetts Institute of Technology	ajb@mit.edu
Dr. Mark S. Marley (CoI)	NASA Ames Research Center	mmarley@mail.arc.nasa.gov
Dr. Sandy K. Leggett (CoI)	Joint Astronomy Centre (JAC)	skl@jach.hawaii.edu
Dr. David A. Golimowski (CoI)	The Johns Hopkins University	dag@pha.jhu.edu
Dr. Didier Saumon (CoI)	Los Alamos National Laboratory	dsaumon@lanl.gov

VISITS

<i>Visit</i>	<i>Targets used in Visit</i>	<i>Configurations used in Visit</i>	<i>Orbits Used</i>	<i>Last Orbit Planner Run</i>	<i>OP Current with Visit?</i>
01	(12) EPS-IND-BAB	NIC1	1	17-Jan-2008 21:54:44.0	yes
02	(1) DENIS0205-1159	NIC1	2	17-Jan-2008 21:55:07.0	yes
03	(2) SDSS0423-04AB	NIC1	2	17-Jan-2008 21:55:26.0	yes
04	(13) 2M2252-17	NIC1	2	17-Jan-2008 21:55:40.0	yes
05	(3) 2M0518-28AB	NIC1	2	17-Jan-2008 21:55:54.0	yes
06	(5) GL-337CD	NIC1	2	17-Jan-2008 21:56:04.0	yes
07	(6) 2M0920+3517AB	NIC1	2	17-Jan-2008 21:56:13.0	yes

<i>Visit</i>	<i>Targets used in Visit</i>	<i>Configurations used in Visit</i>	<i>Orbits Used</i>	<i>Last Orbit Planner Run</i>	<i>OP Current with Visit?</i>
08	(8) SDSS1052+44	NIC1	2	17-Jan-2008 21:56:23.0	yes
09	(7) SDSS1021-03AB	NIC1	3	17-Jan-2008 21:56:37.0	yes
10	(9) SDSS1534+16	NIC1	3	17-Jan-2008 21:56:47.0	yes
11	(10) 2M1728+3948AB	NIC1	3	17-Jan-2008 21:57:02.0	yes
12	(11) SDSS2052-16	NIC1	3	17-Jan-2008 21:57:13.0	yes
13	(4) 2M0850+10AB	NIC1	1	17-Jan-2008 21:57:23.0	yes

28 Total Orbits Used

ABSTRACT

We propose to obtain resolved far-red and near-IR photometry of 13 brown dwarf binaries with HST/NICMOS in order to study one of the long-standing puzzles in ultracool astrophysics, namely the rapid change in spectra from L dwarfs to T dwarfs at nearly constant effective temperature (a.k.a. the "L/T transition"). While many nearby brown dwarfs have been studied, use of such samples is inevitably hindered by the unknown ages, masses, and metallicities of the field population. Characterization of resolved ultracool binaries is a promising avenue for addressing this problem, by providing coeval systems of the same composition with comparable masses and temperatures. Our proposed HST/NICMOS (0.9-1.6 micron) observations will be combined with longer wavelength ground-based photometry and spectroscopy from Keck laser guide star adaptive optics. The resulting multiband (0.9-2.5 micron) dataset will be a unique resource for measuring the evolution of spectral energy distributions across the L/T transition, to test state-of-the-art atmospheric models, and to determine the physical process(es) that dominate the L/T transition. Understanding the L/T transition is important not only for testing brown dwarf atmospheres, but also provides a key pathway for understanding the same physical effects, namely the formation and removal of clouds, in the atmospheres of the extrasolar planets.

OBSERVING DESCRIPTION

We will obtain multiband photometry of 13 L/T transition binaries using NIC1. Ten of these binaries have projected separations $< 0''.2$, and three have separations of $0''.3$ - $0''.7$, so NIC1's pixel scale and field of view are sufficient to resolve the binaries and to allow adequate dithering between exposures. This program comprises 13 visits of 1-3 orbits per visit, depending on the brightness of the targets. The targets are divided into 3 brightness categories, each having a characteristic set of filters, exposure times, and dither patterns. The integration times are chosen so that the binary components are imaged with $S/N \sim 20$ - 30 in each exposure. The dither offsets are $1''.304$ ($30 \frac{1}{3}$ pixels) for all targets except EPS-IND-BAB and GL-337CD, for which the offsets are $2''.164$ ($50 \frac{1}{3}$ pixels) and $1''.734$ ($40 \frac{1}{3}$ pixels), respectively. The 4 brightest targets (DENIS0205-1159, SDSS0423-04AB, EPS-IND-BAB, 2M2252-17) are imaged in 8 bands: F090M, F108N, F113N, F110M, F110W, F145M, F160W, and F170M. Two orbits are allocated to each target except EPS-IND-BAB, which is allocated one orbit. The 4 targets of intermediate brightness (2M0518-28AB, GL-337CD, 2M0920+3517AB, SDSS1052+44) are imaged in 7 bands: F090M, F108N, F110M, F110W, F145M, F160W, and F170M. Two orbits are allocated to each target. Four faint targets (SDSS1021-03AB, SDSS1534+16, 2M1728+3948AB, SDSS2052-16) are imaged in the same 7 bands, but each are allocated 3 orbits. The faintest target, 2M0850+10AB, is imaged in 6 medium and broad bands (F090M, F110M, F110W, F145M, F160W, and F170M) over one orbit.

REAL TIME JUSTIFICATION

N/A

CALIBRATION JUSTIFICATION

N/A

ADDITIONAL COMMENTS

N/A

Proposal 11136 - Visit 01 - Resolving Ultracool Astrophysics with Brown Dwarf Binaries

Fri Jan 18 02:57:27 GMT 2008

Visit	Proposal 11136, Visit 01, implementation Diagnostic Status: No Diagnostics Scientific Instruments: NIC1 Special Requirements: (none)									
	Patterns	#	Primary Pattern	Secondary Pattern	Exposures					
	(1)	Pattern Type=NIC-SPIRAL-DITH Purpose=DITHER Number Of Points=7 Point Spacing=2.164 Line Spacing=	Coordinate Frame=POS-TARG Pattern Orientation=0.0 Angle Between Sides= Center Pattern=false		(1-8)					
Fixed Targets	#	Name	Target Coordinates	Targ. Coord. Corrections	Fluxes	Miscellaneous				
	(12)	EPS-IND-BAB	RA: 22 04 10.5200 (331.0438333d) Dec: -56 46 57.70 (-56.78269d) Equinox: J2000	Proper Motion RA: 0.4817s/yr Proper Motion Dec: -2.541"/yr Parallax: 0.27584" Epoch of Position: 1999.855	V=25 J=12.3	Reference Frame: ICRS				
<i>Comments: Proper motion from Hipparcos.</i>										
Exposures	#	Label	Target	Config,Mode,Aperture	Spectral Els.	Opt. Params.	Special Reqs.	Groups	Exp. Time/[Actual Dur.]	Orbit
	1		(12) EPS-IND-BAB	NIC1, MULTIACCUM, NIC1	F090M	SAMP-SEQ=STEP8 ; NSAMP=8		Pattern 1-8 (1)	[==>(Pattern 1)] [==>(Pattern 2)] [==>(Pattern 3)] [==>(Pattern 4)] [==>(Pattern 5)] [==>(Pattern 6)] [==>(Pattern 7)]	[1]
	2		(12) EPS-IND-BAB	NIC1, MULTIACCUM, NIC1	F110M	SAMP-SEQ=STEP2 ; NSAMP=3		Pattern 1-8 (1)	[==>(Pattern 1)] [==>(Pattern 2)] [==>(Pattern 3)] [==>(Pattern 4)] [==>(Pattern 5)] [==>(Pattern 6)] [==>(Pattern 7)]	[1]
	3		(12) EPS-IND-BAB	NIC1, MULTIACCUM, NIC1	F108N	SAMP-SEQ=STEP2 ; NSAMP=22		Pattern 1-8 (1)	[==>(Pattern 1)] [==>(Pattern 2)] [==>(Pattern 3)] [==>(Pattern 4)] [==>(Pattern 5)] [==>(Pattern 6)] [==>(Pattern 7)]	[1]

Proposal 11136 - Visit 01 - Resolving Ultracool Astrophysics with Brown Dwarf Binaries

#	Label	Target	Config,Mode,Aperture	Spectral Els.	Opt. Params.	Special Reqs.	Groups	Exp. Time/[Actual Dur.]	Orbit
Exposures (continued)	4	(12) EPS-IND-BAB	NIC1, MULTIACCUM, NIC1	F113N	SAMP-SEQ=STEP1 6; NSAMP=15		Pattern 1-8 (1)	[==>(Pattern 1)] [==>(Pattern 2)] [==>(Pattern 3)] [==>(Pattern 4)] [==>(Pattern 5)] [==>(Pattern 6)] [==>(Pattern 7)]	[1]
	5	(12) EPS-IND-BAB	NIC1, MULTIACCUM, NIC1	F160W	SAMP-SEQ=STEP2 ; NSAMP=2		Pattern 1-8 (1)	[==>(Pattern 1)] [==>(Pattern 2)] [==>(Pattern 3)] [==>(Pattern 4)] [==>(Pattern 5)] [==>(Pattern 6)] [==>(Pattern 7)]	[1]
	6	(12) EPS-IND-BAB	NIC1, MULTIACCUM, NIC1	F145M	SAMP-SEQ=STEP2 ; NSAMP=4		Pattern 1-8 (1)	[==>(Pattern 1)] [==>(Pattern 2)] [==>(Pattern 3)] [==>(Pattern 4)] [==>(Pattern 5)] [==>(Pattern 6)] [==>(Pattern 7)]	[1]
	7	(12) EPS-IND-BAB	NIC1, MULTIACCUM, NIC1	F170M	SAMP-SEQ=STEP2 ; NSAMP=3		Pattern 1-8 (1)	[==>(Pattern 1)] [==>(Pattern 2)] [==>(Pattern 3)] [==>(Pattern 4)] [==>(Pattern 5)] [==>(Pattern 6)] [==>(Pattern 7)]	[1]
	8	(12) EPS-IND-BAB	NIC1, MULTIACCUM, NIC1	F110W	SAMP-SEQ=STEP2 ; NSAMP=2		Pattern 1-8 (1)	[==>(Pattern 1)] [==>(Pattern 2)] [==>(Pattern 3)] [==>(Pattern 4)] [==>(Pattern 5)] [==>(Pattern 6)] [==>(Pattern 7)]	[1]

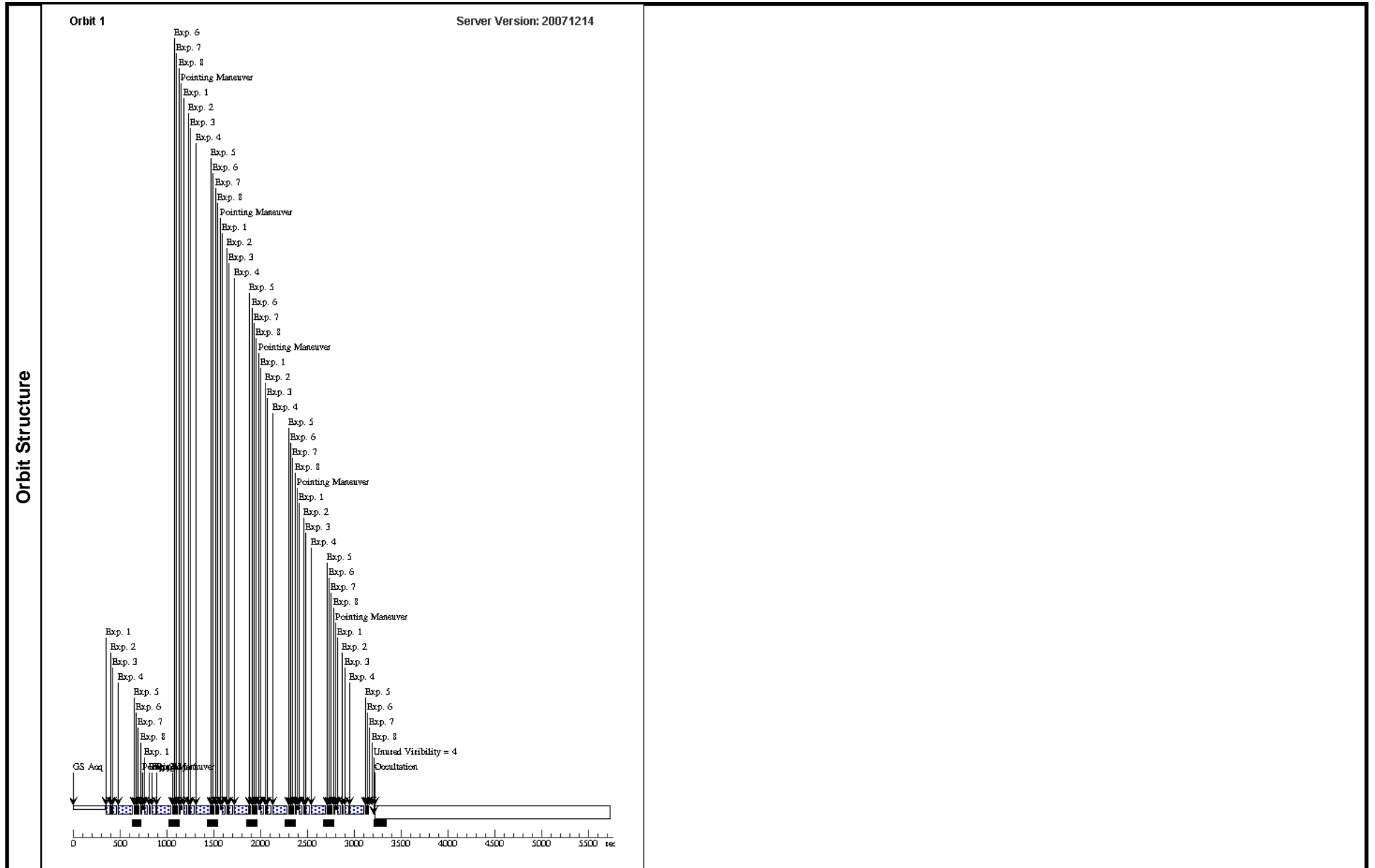

Proposal 11136 - Visit 02 - Resolving Ultracool Astrophysics with Brown Dwarf Binaries

Fri Jan 18 02:57:29 GMT 2008

Visit	Proposal 11136, Visit 02 Diagnostic Status: No Diagnostics Scientific Instruments: NIC1 Special Requirements: (none)									
	Patterns	#	Primary Pattern	Secondary Pattern	Exposures					
		(2)	Pattern Type=NIC-SPIRAL-DITH Purpose=DITHER Number Of Points=5 Point Spacing=1.304 Line Spacing=	Coordinate Frame=POS-TARG Pattern Orientation=0.0 Angle Between Sides= Center Pattern=false		(1-7)				
	(4)	Pattern Type=NIC-SPIRAL-DITH Purpose=DITHER Number Of Points=3 Point Spacing=1.304 Line Spacing=	Coordinate Frame=POS-TARG Pattern Orientation=0.0 Angle Between Sides= Center Pattern=false		(8)					
Fixed Targets	#	Name	Target Coordinates	Targ. Coord. Corrections	Fluxes	Miscellaneous				
	(1)	DENIS0205-1159	RA: 02 05 29.4000 (31.3725000d) Dec: -11 59 29.60 (-11.99156d) Equinox: J2000	Proper Motion RA: 0.0296s/yr Proper Motion Dec: 0.053"/yr Parallax: 0.0506" Epoch of Position: 2000.89	V=25 J=14.6	Reference Frame: ICRS				
Exposures	#	Label	Target	Config,Mode,Aperture	Spectral Els.	Opt. Params.	Special Reqs.	Groups	Exp. Time/[Actual Dur.]	Orbit
	1		(1) DENIS0205-1159	NIC1, MULTIACCUM, NIC1	F090M	SAMP-SEQ=STEP1 6; NSAMP=17			Pattern 1-7 (2)	[==>(Pattern 1)] [==>(Pattern 2)] [==>(Pattern 3)] [==>(Pattern 4)] [==>(Pattern 5)]
2		(1) DENIS0205-1159	NIC1, MULTIACCUM, NIC1	F110M	SAMP-SEQ=STEP8 ; NSAMP=8			Pattern 1-7 (2)	[==>(Pattern 1)] [==>(Pattern 2)] [==>(Pattern 3)] [==>(Pattern 4)] [==>(Pattern 5)]	[1] [2]
3		(1) DENIS0205-1159	NIC1, MULTIACCUM, NIC1	F108N	SAMP-SEQ=STEP1 28; NSAMP=11			Pattern 1-7 (2)	[==>(Pattern 1)] [==>(Pattern 2)] [==>(Pattern 3)] [==>(Pattern 4)] [==>(Pattern 5)]	[1] [2]

Proposal 11136 - Visit 02 - Resolving Ultracool Astrophysics with Brown Dwarf Binaries

Exposures (continued)	#	Label	Target	Config,Mode,Aperture	Spectral Els.	Opt. Params.	Special Reqs.	Groups	Exp. Time/[Actual Dur.]	Orbit
	4		(1) DENIS0205-115 9	NIC1, MULTIACCUM, NIC1	F160W	SAMP-SEQ=STEP1 ; NSAMP=7		Pattern 1-7 (2)	[==>(Pattern 1)] [==>(Pattern 2)] [==>(Pattern 3)] [==>(Pattern 4)] [==>(Pattern 5)]	[1] [2]
	5		(1) DENIS0205-115 9	NIC1, MULTIACCUM, NIC1	F145M	SAMP-SEQ=STEP3 2; NSAMP=9		Pattern 1-7 (2)	[==>(Pattern 1)] [==>(Pattern 2)] [==>(Pattern 3)] [==>(Pattern 4)] [==>(Pattern 5)]	[1] [2]
	6		(1) DENIS0205-115 9	NIC1, MULTIACCUM, NIC1	F170M	SAMP-SEQ=STEP1 6; NSAMP=8		Pattern 1-7 (2)	[==>(Pattern 1)] [==>(Pattern 2)] [==>(Pattern 3)] [==>(Pattern 4)] [==>(Pattern 5)]	[1] [2]
	7		(1) DENIS0205-115 9	NIC1, MULTIACCUM, NIC1	F110W	SAMP-SEQ=STEP1 ; NSAMP=5		Pattern 1-7 (2)	[==>(Pattern 1)] [==>(Pattern 2)] [==>(Pattern 3)] [==>(Pattern 4)] [==>(Pattern 5)]	[1] [2]
	8		(1) DENIS0205-115 9	NIC1, MULTIACCUM, NIC1	F113N	SAMP-SEQ=STEP6 4; NSAMP=17		Pattern 8-8 (4)	[==>(Pattern 1)] [==>(Pattern 2)] [==>(Pattern 3)]	[2] [2]

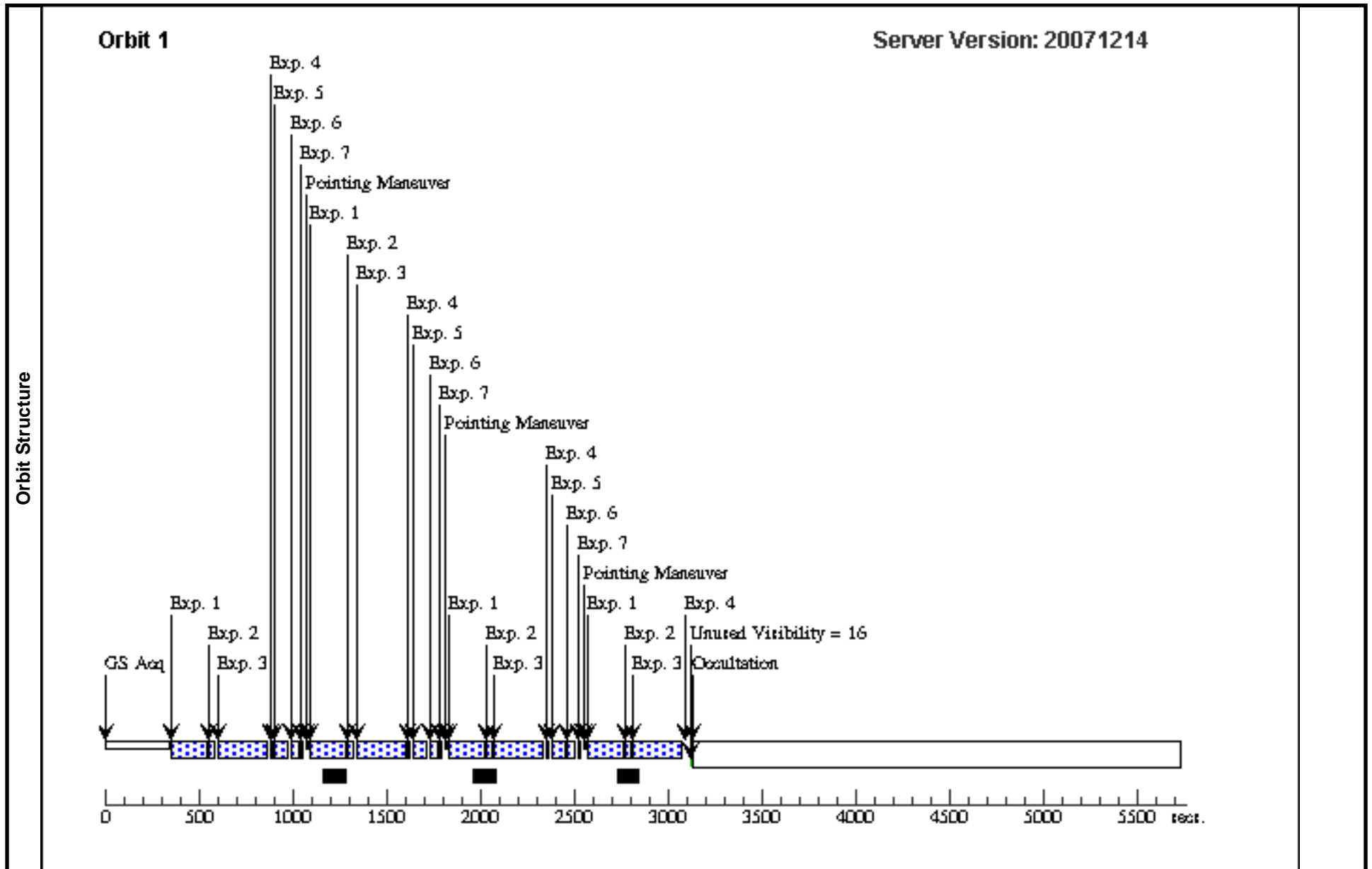

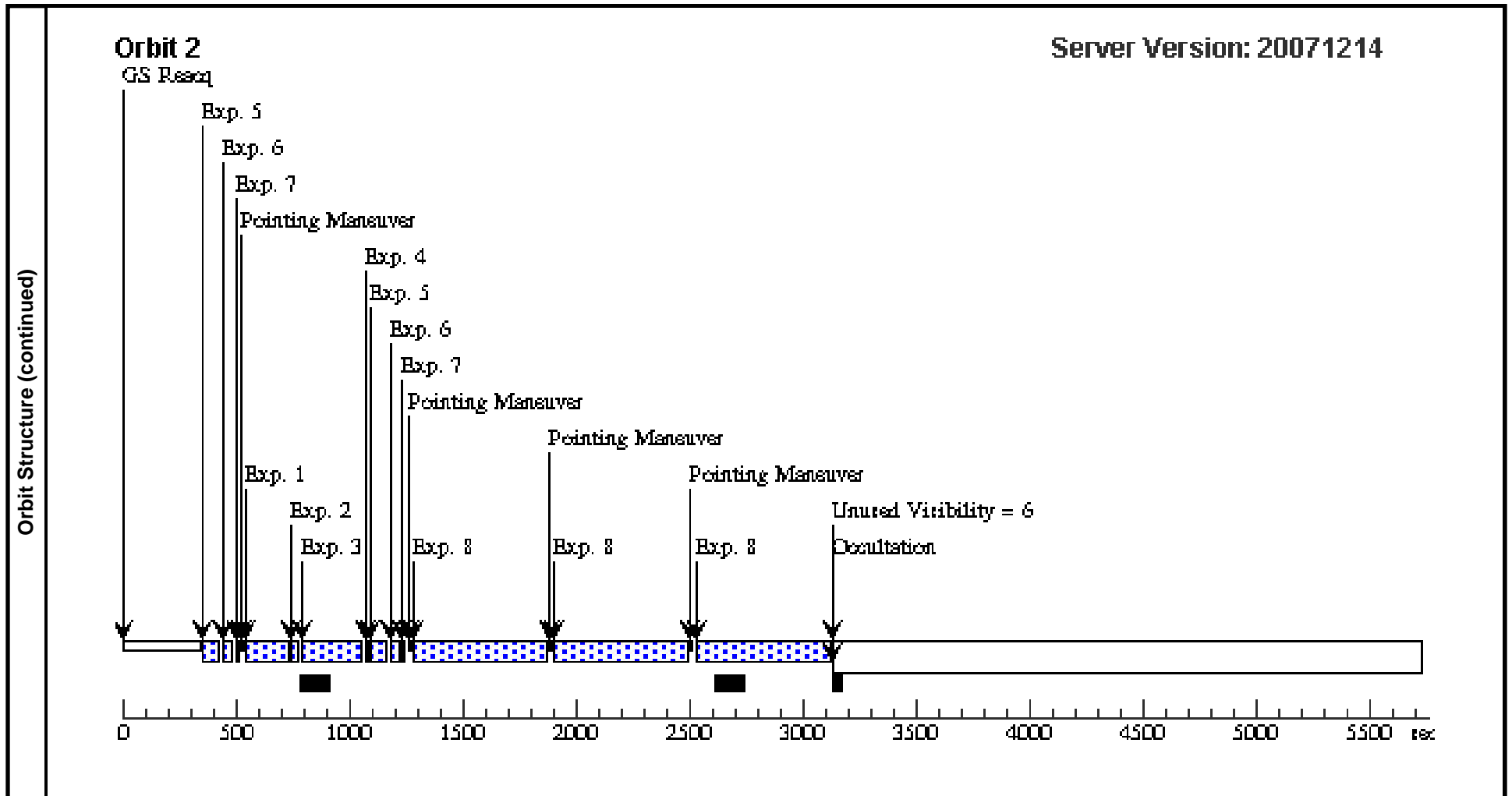

Proposal 11136 - Visit 03 - Resolving Ultracool Astrophysics with Brown Dwarf Binaries

Fri Jan 18 02:57:30 GMT 2008

Visit	Proposal 11136, Visit 03 Diagnostic Status: No Diagnostics Scientific Instruments: NIC1 Special Requirements: (none)									
	Patterns	#	Primary Pattern	Secondary Pattern	Exposures					
		(2)	Pattern Type=NIC-SPIRAL-DITH Purpose=DITHER Number Of Points=5 Point Spacing=1.304 Line Spacing=	Coordinate Frame=POS-TARG Pattern Orientation=0.0 Angle Between Sides= Center Pattern=false		(1-7)				
	(4)	Pattern Type=NIC-SPIRAL-DITH Purpose=DITHER Number Of Points=3 Point Spacing=1.304 Line Spacing=	Coordinate Frame=POS-TARG Pattern Orientation=0.0 Angle Between Sides= Center Pattern=false		(8)					
Fixed Targets	#	Name	Target Coordinates	Targ. Coord. Corrections	Fluxes	Miscellaneous				
	(2)	SDSS0423-04AB	RA: 04 23 48.5800 (65.9524167d) Dec: -04 14 3.50 (-4.23431d) Equinox: J2000	Proper Motion RA: -0.0216s/yr Proper Motion Dec: 0.081"/yr Parallax: 0.06593" Epoch of Position: 1998.734	V=25 J=14.5	Reference Frame: ICRS				
Exposures	#	Label	Target	Config,Mode,Aperture	Spectral Els.	Opt. Params.	Special Reqs.	Groups	Exp. Time/[Actual Dur.]	Orbit
	1		(2) SDSS0423-04AB	NIC1, MULTIACCUM, NIC1	F090M	SAMP-SEQ=STEP1 6; NSAMP=17		Pattern 1-7 (2)	[==>(Pattern 1)] [==>(Pattern 2)] [==>(Pattern 3)] [==>(Pattern 4)] [==>(Pattern 5)]	[1] [2]
2		(2) SDSS0423-04AB	NIC1, MULTIACCUM, NIC1	F110M	SAMP-SEQ=STEP8 ; NSAMP=8		Pattern 1-7 (2)	[==>(Pattern 1)] [==>(Pattern 2)] [==>(Pattern 3)] [==>(Pattern 4)] [==>(Pattern 5)]	[1] [2]	
3		(2) SDSS0423-04AB	NIC1, MULTIACCUM, NIC1	F108N	SAMP-SEQ=STEP1 28; NSAMP=11		Pattern 1-7 (2)	[==>(Pattern 1)] [==>(Pattern 2)] [==>(Pattern 3)] [==>(Pattern 4)] [==>(Pattern 5)]	[1] [2]	

Proposal 11136 - Visit 03 - Resolving Ultracool Astrophysics with Brown Dwarf Binaries

#	Label	Target	Config,Mode,Aperture	Spectral Els.	Opt. Params.	Special Reqs.	Groups	Exp. Time/[Actual Dur.]	Orbit
Exposures (continued)	4	(2) SDSS0423-04AB	NIC1, MULTIACCUM, NIC1	F160W	SAMP-SEQ=STEP1 ; NSAMP=7		Pattern 1-7 (2)	[==>(Pattern 1)] [==>(Pattern 2)] [==>(Pattern 3)] [==>(Pattern 4)] [==>(Pattern 5)]	[1] [2]
	5	(2) SDSS0423-04AB	NIC1, MULTIACCUM, NIC1	F145M	SAMP-SEQ=STEP3 2; NSAMP=9		Pattern 1-7 (2)	[==>(Pattern 1)] [==>(Pattern 2)] [==>(Pattern 3)] [==>(Pattern 4)] [==>(Pattern 5)]	[1] [2]
	6	(2) SDSS0423-04AB	NIC1, MULTIACCUM, NIC1	F170M	SAMP-SEQ=STEP1 6; NSAMP=8		Pattern 1-7 (2)	[==>(Pattern 1)] [==>(Pattern 2)] [==>(Pattern 3)] [==>(Pattern 4)] [==>(Pattern 5)]	[1] [2]
	7	(2) SDSS0423-04AB	NIC1, MULTIACCUM, NIC1	F110W	SAMP-SEQ=STEP1 ; NSAMP=5		Pattern 1-7 (2)	[==>(Pattern 1)] [==>(Pattern 2)] [==>(Pattern 3)] [==>(Pattern 4)] [==>(Pattern 5)]	[1] [2]
	8	(2) SDSS0423-04AB	NIC1, MULTIACCUM, NIC1	F113N	SAMP-SEQ=STEP6 4; NSAMP=17		Pattern 8-8 (4)	[==>(Pattern 1)] [==>(Pattern 2)] [==>(Pattern 3)]	[2] [2]

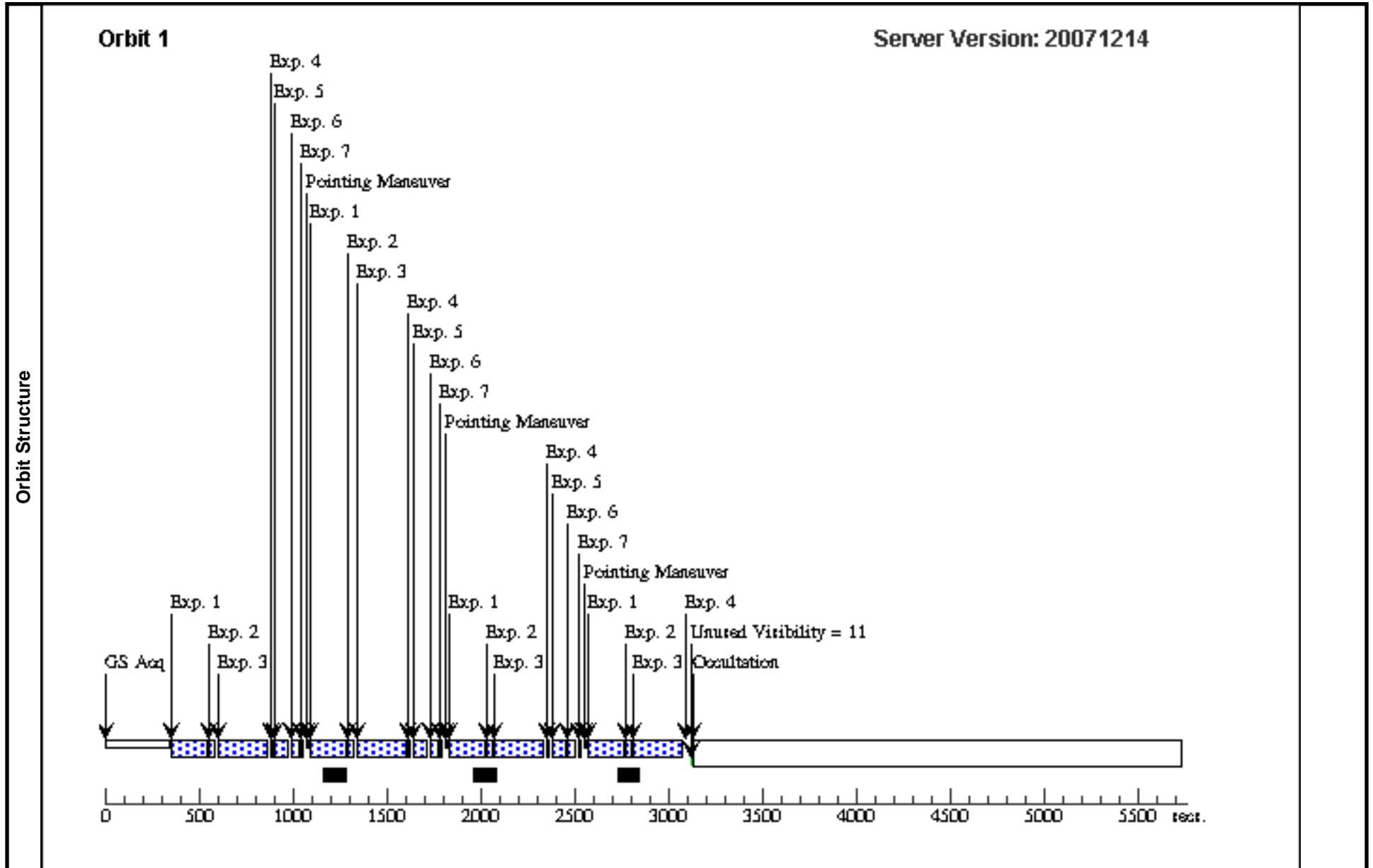

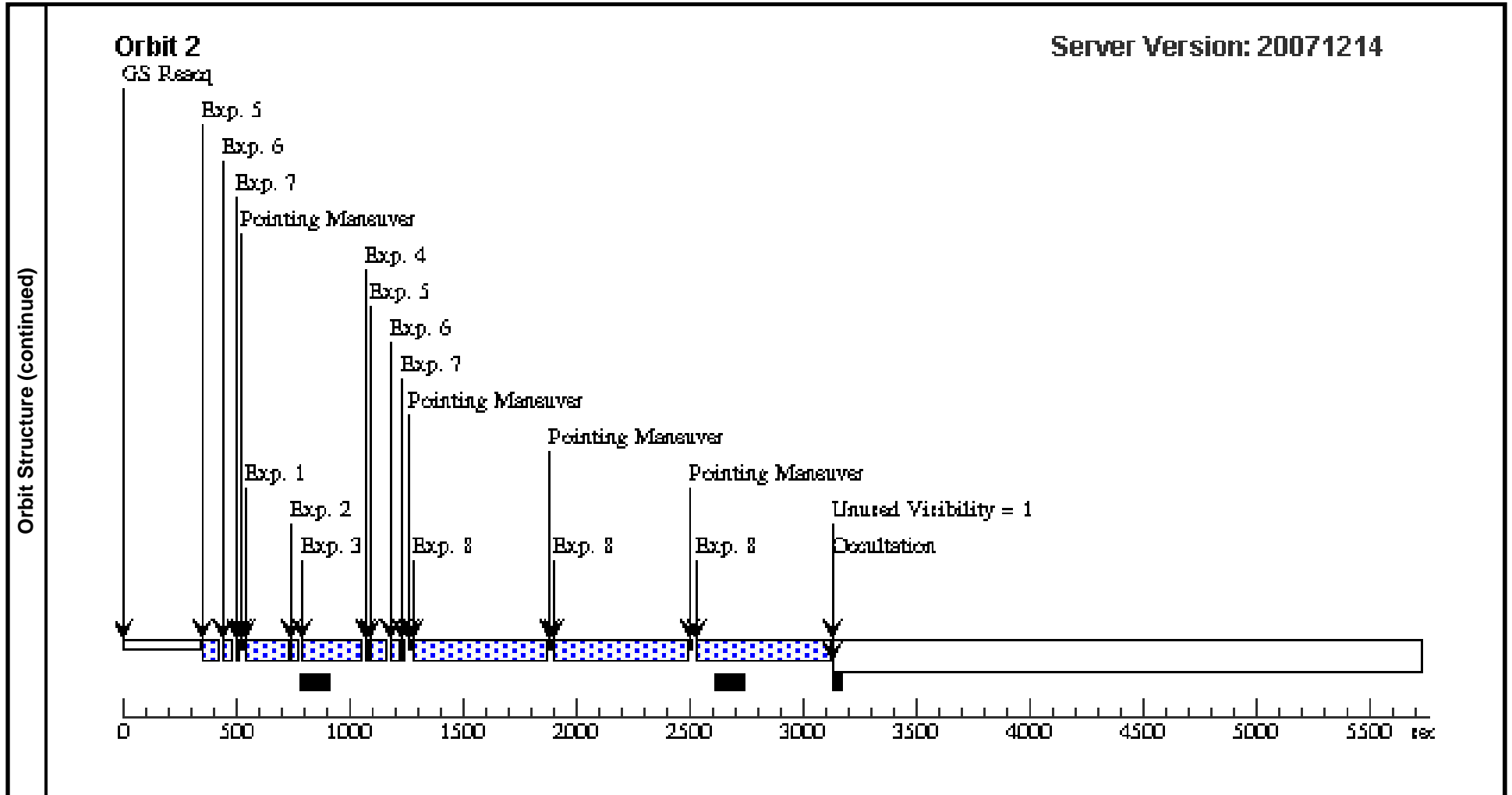

Proposal 11136 - Visit 04 - Resolving Ultracool Astrophysics with Brown Dwarf Binaries

Fri Jan 18 02:57:31 GMT 2008

Visit	Proposal 11136, Visit 04 Diagnostic Status: No Diagnostics Scientific Instruments: NIC1 Special Requirements: (none)									
	Patterns	#	Primary Pattern	Secondary Pattern	Exposures					
		(2)	Pattern Type=NIC-SPIRAL-DITH Purpose=DITHER Number Of Points=5 Point Spacing=1.304 Line Spacing=	Coordinate Frame=POS-TARG Pattern Orientation=0.0 Angle Between Sides= Center Pattern=false		(1-7)				
	(4)	Pattern Type=NIC-SPIRAL-DITH Purpose=DITHER Number Of Points=3 Point Spacing=1.304 Line Spacing=	Coordinate Frame=POS-TARG Pattern Orientation=0.0 Angle Between Sides= Center Pattern=false		(8)					
Fixed Targets	#	Name	Target Coordinates	Targ. Coord. Corrections	Fluxes	Miscellaneous				
	(13)	2M2252-17 Alt Name1: DENIS2252-1730	RA: 22 52 10.7300 (343.0447083d) Dec: -17 30 13.40 (-17.50372d) Equinox: J2000	Proper Motion RA: 0.0294s/yr Proper Motion Dec: 0.15"/yr Epoch of Position: 1999.515	V=25 J=14.3	Reference Frame: ICRS				
Exposures	#	Label	Target	Config,Mode,Aperture	Spectral Els.	Opt. Params.	Special Reqs.	Groups	Exp. Time/[Actual Dur.]	Orbit
	1		(13) 2M2252-17	NIC1, MULTIACCUM, NIC1	F090M	SAMP-SEQ=STEP1 6; NSAMP=17		Pattern 1-7 (2)	[==>(Pattern 1)] [==>(Pattern 2)] [==>(Pattern 3)] [==>(Pattern 4)] [==>(Pattern 5)]	[1] [2]
	2		(13) 2M2252-17	NIC1, MULTIACCUM, NIC1	F110M	SAMP-SEQ=STEP8 ; NSAMP=8		Pattern 1-7 (2)	[==>(Pattern 1)] [==>(Pattern 2)] [==>(Pattern 3)] [==>(Pattern 4)] [==>(Pattern 5)]	[1] [2]
	3		(13) 2M2252-17	NIC1, MULTIACCUM, NIC1	F108N	SAMP-SEQ=STEP1 28; NSAMP=11		Pattern 1-7 (2)	[==>(Pattern 1)] [==>(Pattern 2)] [==>(Pattern 3)] [==>(Pattern 4)] [==>(Pattern 5)]	[1] [2]

Proposal 11136 - Visit 04 - Resolving Ultracool Astrophysics with Brown Dwarf Binaries

Exposures (continued)	#	Label	Target	Config,Mode,Aperture	Spectral Els.	Opt. Params.	Special Reqs.	Groups	Exp. Time/[Actual Dur.]	Orbit
	4		(13) 2M2252-17	NIC1, MULTIACCUM, NIC1	F160W	SAMP-SEQ=STEP1 ; NSAMP=7		Pattern 1-7 (2)	[==>(Pattern 1)] [==>(Pattern 2)] [==>(Pattern 3)] [==>(Pattern 4)] [==>(Pattern 5)]	[1] [2]
	5		(13) 2M2252-17	NIC1, MULTIACCUM, NIC1	F145M	SAMP-SEQ=STEP3 2; NSAMP=9		Pattern 1-7 (2)	[==>(Pattern 1)] [==>(Pattern 2)] [==>(Pattern 3)] [==>(Pattern 4)] [==>(Pattern 5)]	[1] [2]
	6		(13) 2M2252-17	NIC1, MULTIACCUM, NIC1	F170M	SAMP-SEQ=STEP1 6; NSAMP=8		Pattern 1-7 (2)	[==>(Pattern 1)] [==>(Pattern 2)] [==>(Pattern 3)] [==>(Pattern 4)] [==>(Pattern 5)]	[1] [2]
	7		(13) 2M2252-17	NIC1, MULTIACCUM, NIC1	F110W	SAMP-SEQ=STEP1 ; NSAMP=5		Pattern 1-7 (2)	[==>(Pattern 1)] [==>(Pattern 2)] [==>(Pattern 3)] [==>(Pattern 4)] [==>(Pattern 5)]	[1] [2]
	8		(13) 2M2252-17	NIC1, MULTIACCUM, NIC1	F113N	SAMP-SEQ=STEP6 4; NSAMP=17		Pattern 8-8 (4)	[==>(Pattern 1)] [==>(Pattern 2)] [==>(Pattern 3)]	[2] [2]

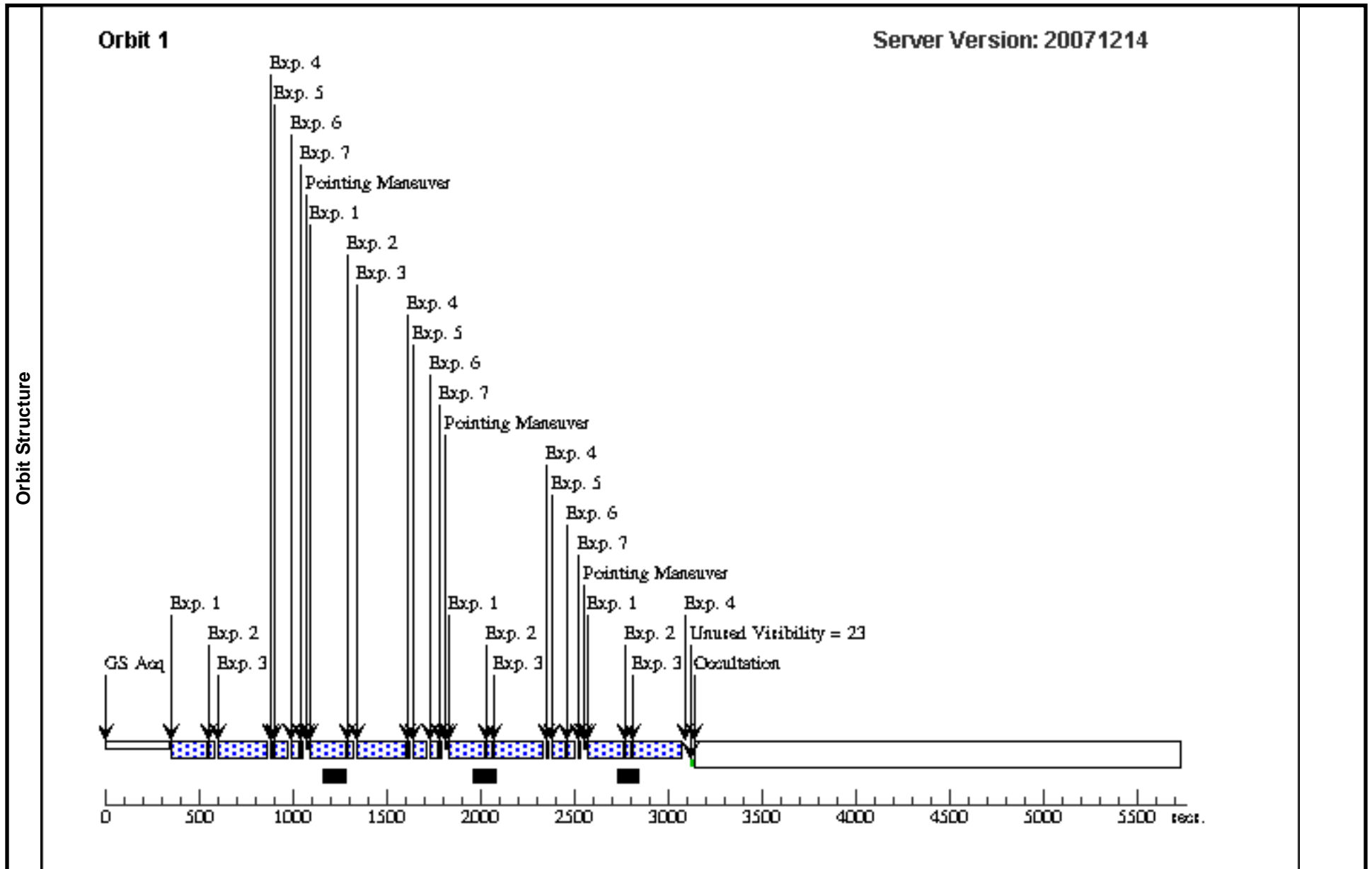

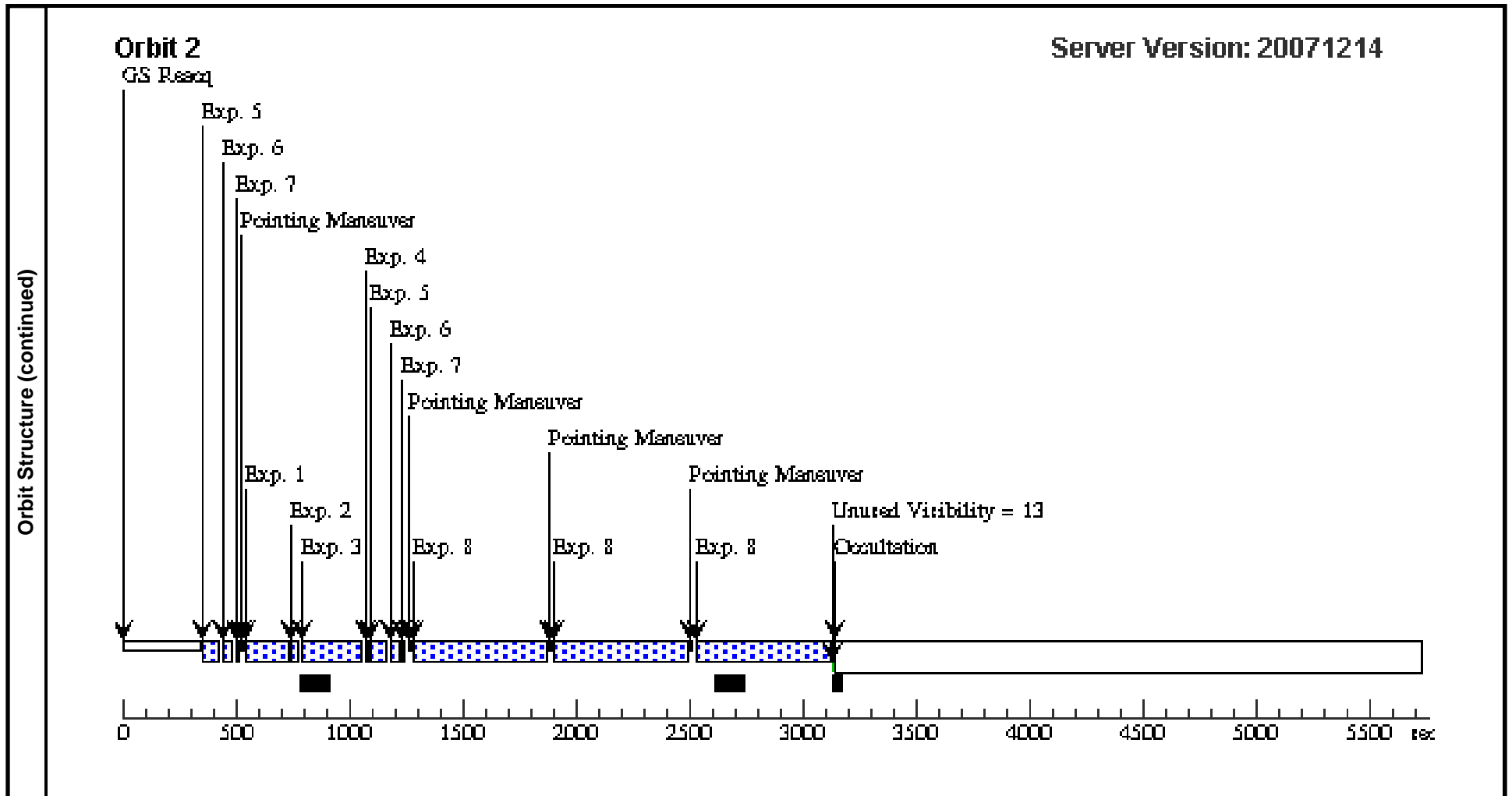

Proposal 11136 - Visit 05 - Resolving Ultracool Astrophysics with Brown Dwarf Binaries

Fri Jan 18 02:57:33 GMT 2008

Visit	Proposal 11136, Visit 05, implementation Diagnostic Status: No Diagnostics Scientific Instruments: NIC1 Special Requirements: (none)									
	Patterns	#	Primary Pattern	Secondary Pattern	Exposures					
	(3)	Pattern Type=NIC-SPIRAL-DITH Purpose=DITHER Number Of Points=4 Point Spacing=1.304 Line Spacing=	Coordinate Frame=POS-TARG Pattern Orientation=0.0 Angle Between Sides= Center Pattern=false		(1-7)					
Fixed Targets	#	Name	Target Coordinates	Targ. Coord. Corrections	Fluxes	Miscellaneous				
	(3)	2M0518-28AB	RA: 05 18 59.9500 (79.7497917d) Dec: -28 28 37.20 (-28.47700d) Equinox: J2000	Proper Motion RA: -0.0079s/yr Proper Motion Dec: -0.621"/yr Epoch of Position: 1999.016	V=25 J=16.0	Reference Frame: ICRS				
Exposures	#	Label	Target	Config,Mode,Aperture	Spectral Els.	Opt. Params.	Special Reqs.	Groups	Exp. Time/[Actual Dur.]	Orbit
	1	(3) 2M0518-28AB	NIC1, MULTIACCUM, NIC1	F090M	SAMP-SEQ=STEP3 2; NSAMP=20			Pattern 1-7 (3)	[==>(Pattern 1)]	[1]
									[==>(Pattern 2)]	
									[==>(Pattern 3)]	[2]
									[==>(Pattern 4)]	
	2	(3) 2M0518-28AB	NIC1, MULTIACCUM, NIC1	F110M	SAMP-SEQ=STEP1 6; NSAMP=8			Pattern 1-7 (3)	[==>(Pattern 1)]	[1]
									[==>(Pattern 2)]	
									[==>(Pattern 3)]	[2]
									[==>(Pattern 4)]	
	3	(3) 2M0518-28AB	NIC1, MULTIACCUM, NIC1	F108N	SAMP-SEQ=STEP1 28; NSAMP=14			Pattern 1-7 (3)	[==>(Pattern 1)]	[1]
									[==>(Pattern 2)]	
									[==>(Pattern 3)]	[2]
									[==>(Pattern 4)]	
	4	(3) 2M0518-28AB	NIC1, MULTIACCUM, NIC1	F160W	SAMP-SEQ=STEP2 ; NSAMP=9			Pattern 1-7 (3)	[==>(Pattern 1)]	[1]
									[==>(Pattern 2)]	
								[==>(Pattern 3)]	[2]	
								[==>(Pattern 4)]		
5	(3) 2M0518-28AB	NIC1, MULTIACCUM, NIC1	F145M	SAMP-SEQ=STEP3 2; NSAMP=9			Pattern 1-7 (3)	[==>(Pattern 1)]	[1]	
								[==>(Pattern 2)]		
								[==>(Pattern 3)]	[2]	
								[==>(Pattern 4)]		

Proposal 11136 - Visit 05 - Resolving Ultracool Astrophysics with Brown Dwarf Binaries

Exposures (continued)	#	Label	Target	Config, Mode, Aperture	Spectral Els.	Opt. Params.	Special Reqs.	Groups	Exp. Time/[Actual Dur.]	Orbit
	6		(3) 2M0518-28AB	NIC1, MULTIACCUM, NIC1	F170M	SAMP-SEQ=STEP8 ; NSAMP=10		Pattern 1-7 (3)	[==>(Pattern 1)] [==>(Pattern 2)] [==>(Pattern 3)] [==>(Pattern 4)]	[1] [2]
7		(3) 2M0518-28AB	NIC1, MULTIACCUM, NIC1	F110W	SAMP-SEQ=STEP8 ; NSAMP=6		Pattern 1-7 (3)	[==>(Pattern 1)] [==>(Pattern 2)] [==>(Pattern 3)] [==>(Pattern 4)]	[1] [2]	

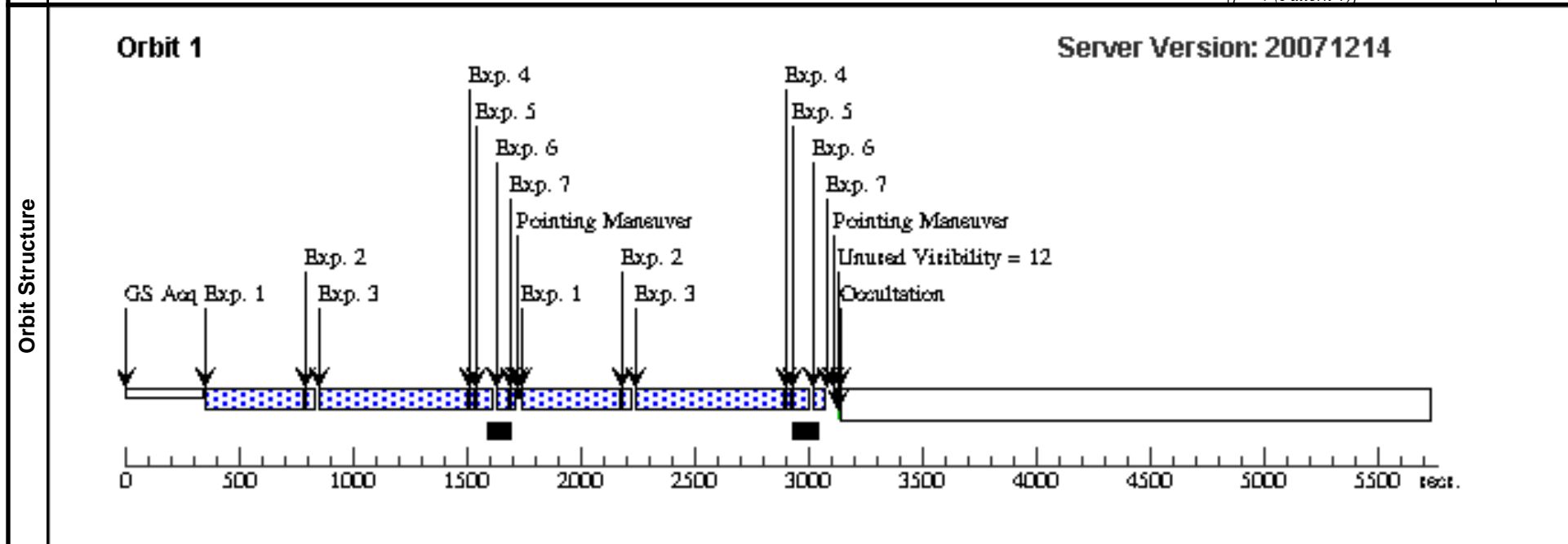

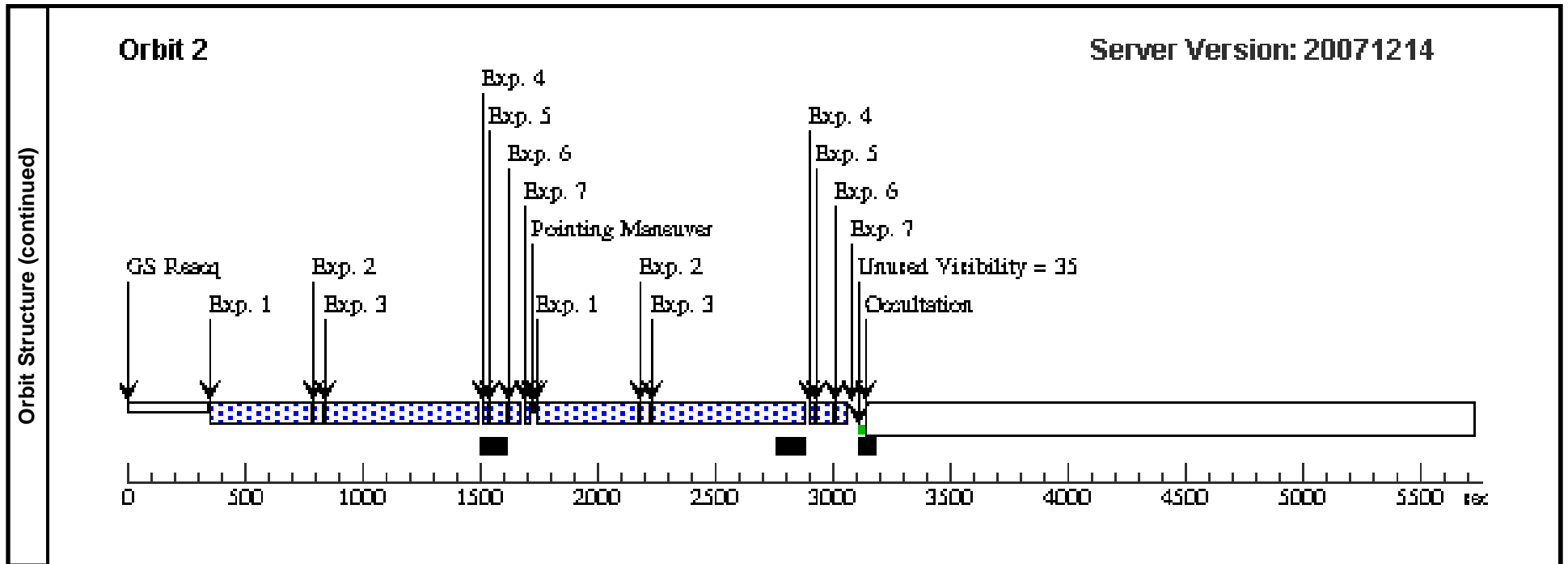

Proposal 11136 - Visit 06 - Resolving Ultracool Astrophysics with Brown Dwarf Binaries

Fri Jan 18 02:57:33 GMT 2008

Visit	Proposal 11136, Visit 06 Diagnostic Status: No Diagnostics Scientific Instruments: NIC1 Special Requirements: (none)									
	Patterns	#	Primary Pattern	Secondary Pattern	Exposures					
		(5)	Pattern Type=NIC-SPIRAL-DITH Purpose=DITHER Number Of Points=4 Point Spacing=1.734 Line Spacing=	Coordinate Frame=POS-TARG Pattern Orientation=0.0 Angle Between Sides= Center Pattern=false		(1-7)				
Fixed Targets	#	Name	Target Coordinates	Targ. Coord. Corrections	Fluxes	Miscellaneous				
	(5)	GL-337CD	RA: 09 12 14.6900 (138.0612083d) Dec: +14 59 39.60 (14.99433d) Equinox: J2000	Proper Motion RA: -0.0362s/yr Proper Motion Dec: 0.245"/yr Parallax: 0.0456" Epoch of Position: 1997.882	V=25 J=15.5	Reference Frame: ICRS				
	<i>Comments: Parallax and proper motion from Hipparcos.</i>									
Exposures	#	Label	Target	Config,Mode,Aperture	Spectral Els.	Opt. Params.	Special Reqs.	Groups	Exp. Time/[Actual Dur.]	Orbit
	1	(5) GL-337CD	NIC1, MULTIACCUM, NIC1	F090M	SAMP-SEQ=STEP3 2; NSAMP=20			Pattern 1-7 (5)	[==>(Pattern 1)]	[1]
									[==>(Pattern 2)]	
									[==>(Pattern 3)]	[2]
									[==>(Pattern 4)]	
	2	(5) GL-337CD	NIC1, MULTIACCUM, NIC1	F110M	SAMP-SEQ=STEP1 6; NSAMP=8			Pattern 1-7 (5)	[==>(Pattern 1)]	[1]
									[==>(Pattern 2)]	
									[==>(Pattern 3)]	[2]
									[==>(Pattern 4)]	
	3	(5) GL-337CD	NIC1, MULTIACCUM, NIC1	F108N	SAMP-SEQ=STEP1 28; NSAMP=14			Pattern 1-7 (5)	[==>(Pattern 1)]	[1]
								[==>(Pattern 2)]		
								[==>(Pattern 3)]	[2]	
								[==>(Pattern 4)]		
4	(5) GL-337CD	NIC1, MULTIACCUM, NIC1	F160W	SAMP-SEQ=STEP2 ; NSAMP=9			Pattern 1-7 (5)	[==>(Pattern 1)]	[1]	
								[==>(Pattern 2)]		
								[==>(Pattern 3)]	[2]	
								[==>(Pattern 4)]		
5	(5) GL-337CD	NIC1, MULTIACCUM, NIC1	F145M	SAMP-SEQ=STEP3 2; NSAMP=9			Pattern 1-7 (5)	[==>(Pattern 1)]	[1]	
								[==>(Pattern 2)]		
								[==>(Pattern 3)]	[2]	
								[==>(Pattern 4)]		

Proposal 11136 - Visit 06 - Resolving Ultracool Astrophysics with Brown Dwarf Binaries

Exposures (continued)	#	Label	Target	Config,Mode,Aperture	Spectral Els.	Opt. Params.	Special Reqs.	Groups	Exp. Time/[Actual Dur.]	Orbit
	6		(5) GL-337CD	NIC1, MULTIACCUM, NIC1	F170M	SAMP-SEQ=STEP8 ; NSAMP=10		Pattern 1-7 (5)	[==>(Pattern 1)] [==>(Pattern 2)] [==>(Pattern 3)] [==>(Pattern 4)]	[1] [2]
7		(5) GL-337CD	NIC1, MULTIACCUM, NIC1	F110W	SAMP-SEQ=STEP8 ; NSAMP=6		Pattern 1-7 (5)	[==>(Pattern 1)] [==>(Pattern 2)] [==>(Pattern 3)] [==>(Pattern 4)]	[1] [2]	

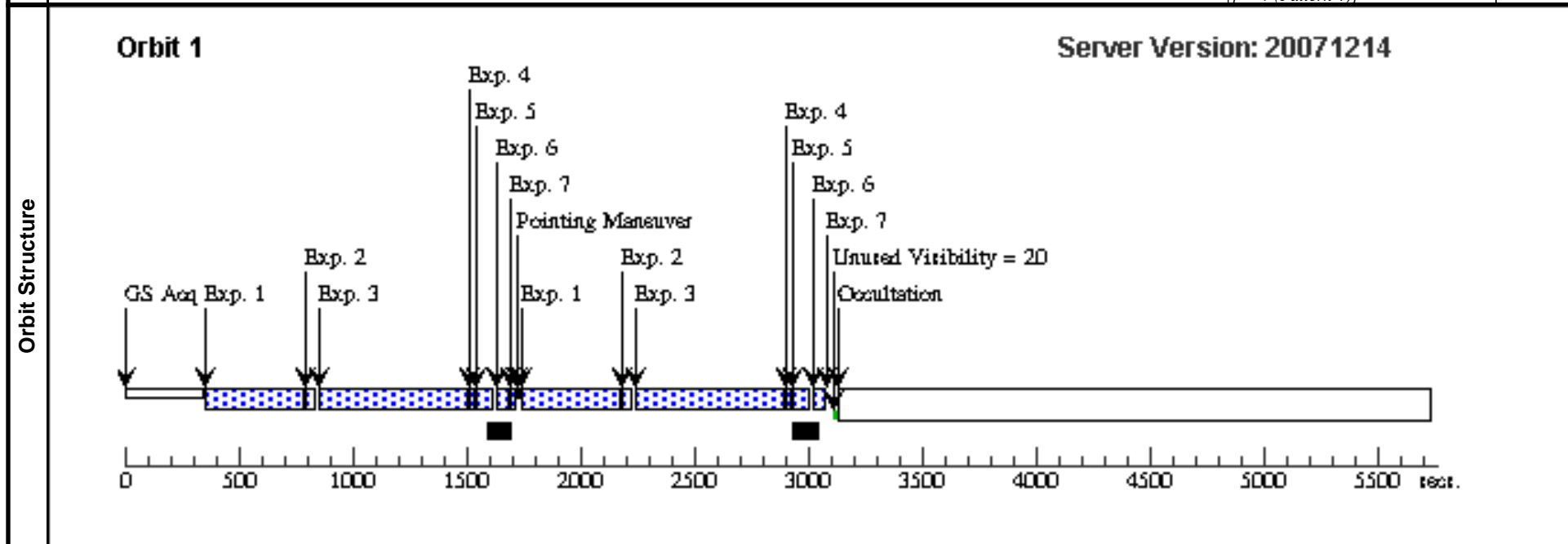

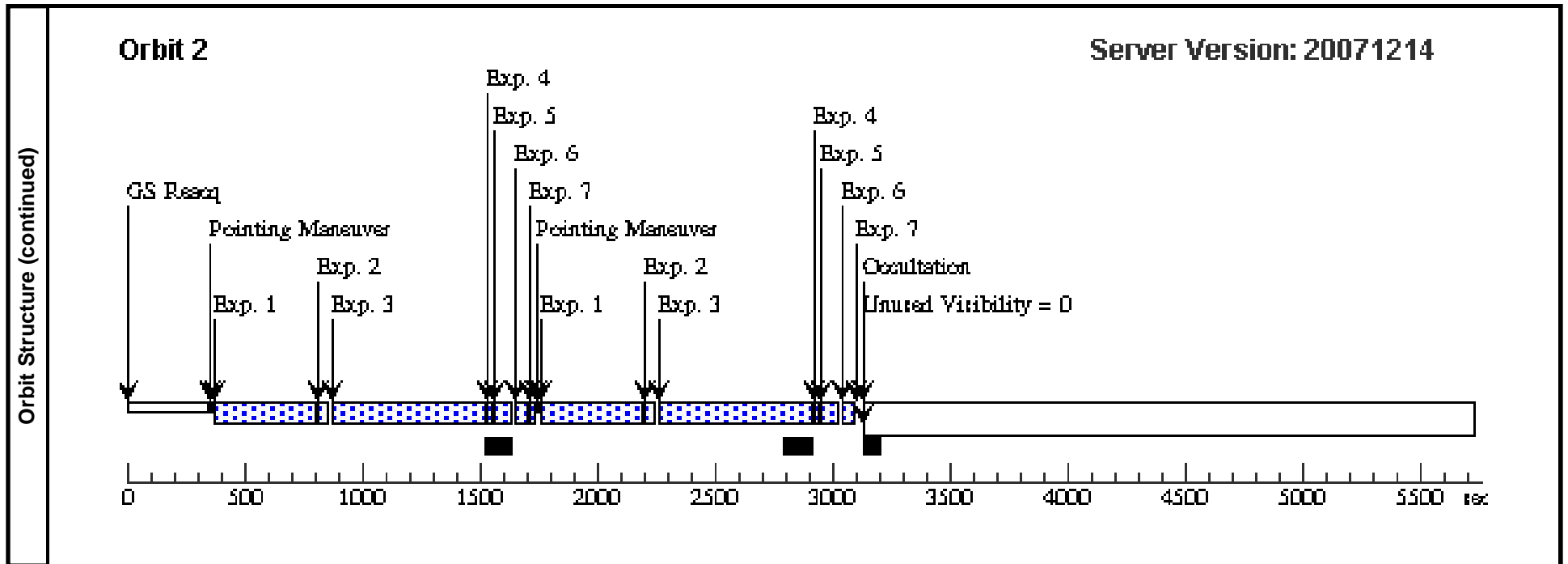

Proposal 11136 - Visit 07 - Resolving Ultracool Astrophysics with Brown Dwarf Binaries

Fri Jan 18 02:57:34 GMT 2008

Visit	Proposal 11136, Visit 07 Diagnostic Status: No Diagnostics Scientific Instruments: NIC1 Special Requirements: (none)									
	Patterns	#	Primary Pattern	Secondary Pattern	Exposures					
	(3)	Pattern Type=NIC-SPIRAL-DITH Purpose=DITHER Number Of Points=4 Point Spacing=1.304 Line Spacing=	Coordinate Frame=POS-TARG Pattern Orientation=0.0 Angle Between Sides= Center Pattern=false		(1-7)					
Fixed Targets	#	Name	Target Coordinates	Targ. Coord. Corrections	Fluxes	Miscellaneous				
	(6)	2M0920+3517AB	RA: 09 20 12.2300 (140.0509583d) Dec: +35 17 42.90 (35.29525d) Equinox: J2000	Proper Motion RA: -0.0131s/yr Proper Motion Dec: -0.182"/yr Epoch of Position: 1998.227	V=25 J=15.6	Reference Frame: ICRS				
Exposures	#	Label	Target	Config,Mode,Aperture	Spectral Els.	Opt. Params.	Special Reqs.	Groups	Exp. Time/[Actual Dur.]	Orbit
	1		(6) 2M0920+3517A B	NIC1, MULTIACCUM, NIC1	F090M	SAMP-SEQ=STEP3 2; NSAMP=20		Pattern 1-7 (3)	[==>(Pattern 1)] [==>(Pattern 2)] [==>(Pattern 3)] [==>(Pattern 4)]	[1] [2]
	2		(6) 2M0920+3517A B	NIC1, MULTIACCUM, NIC1	F110M	SAMP-SEQ=STEP1 6; NSAMP=8		Pattern 1-7 (3)	[==>(Pattern 1)] [==>(Pattern 2)] [==>(Pattern 3)] [==>(Pattern 4)]	[1] [2]
	3		(6) 2M0920+3517A B	NIC1, MULTIACCUM, NIC1	F108N	SAMP-SEQ=STEP1 28; NSAMP=14		Pattern 1-7 (3)	[==>(Pattern 1)] [==>(Pattern 2)] [==>(Pattern 3)] [==>(Pattern 4)]	[1] [2]
	4		(6) 2M0920+3517A B	NIC1, MULTIACCUM, NIC1	F160W	SAMP-SEQ=STEP2 ; NSAMP=9		Pattern 1-7 (3)	[==>(Pattern 1)] [==>(Pattern 2)] [==>(Pattern 3)] [==>(Pattern 4)]	[1] [2]
	5		(6) 2M0920+3517A B	NIC1, MULTIACCUM, NIC1	F145M	SAMP-SEQ=STEP3 2; NSAMP=9		Pattern 1-7 (3)	[==>(Pattern 1)] [==>(Pattern 2)] [==>(Pattern 3)] [==>(Pattern 4)]	[1] [2]

Proposal 11136 - Visit 07 - Resolving Ultracool Astrophysics with Brown Dwarf Binaries

Exposures (continued)	#	Label	Target	Config, Mode, Aperture	Spectral Els.	Opt. Params.	Special Reqs.	Groups	Exp. Time/[Actual Dur.]	Orbit
	6		(6) 2M0920+3517A B	NIC1, MULTIACCUM, NIC1	F170M	SAMP-SEQ=STEP8 ; NSAMP=10		Pattern 1-7 (3)	[==>(Pattern 1)] [==>(Pattern 2)] [==>(Pattern 3)] [==>(Pattern 4)]	[1] [2]
7		(6) 2M0920+3517A B	NIC1, MULTIACCUM, NIC1	F110W	SAMP-SEQ=STEP8 ; NSAMP=6		Pattern 1-7 (3)	[==>(Pattern 1)] [==>(Pattern 2)] [==>(Pattern 3)] [==>(Pattern 4)]	[1] [2]	

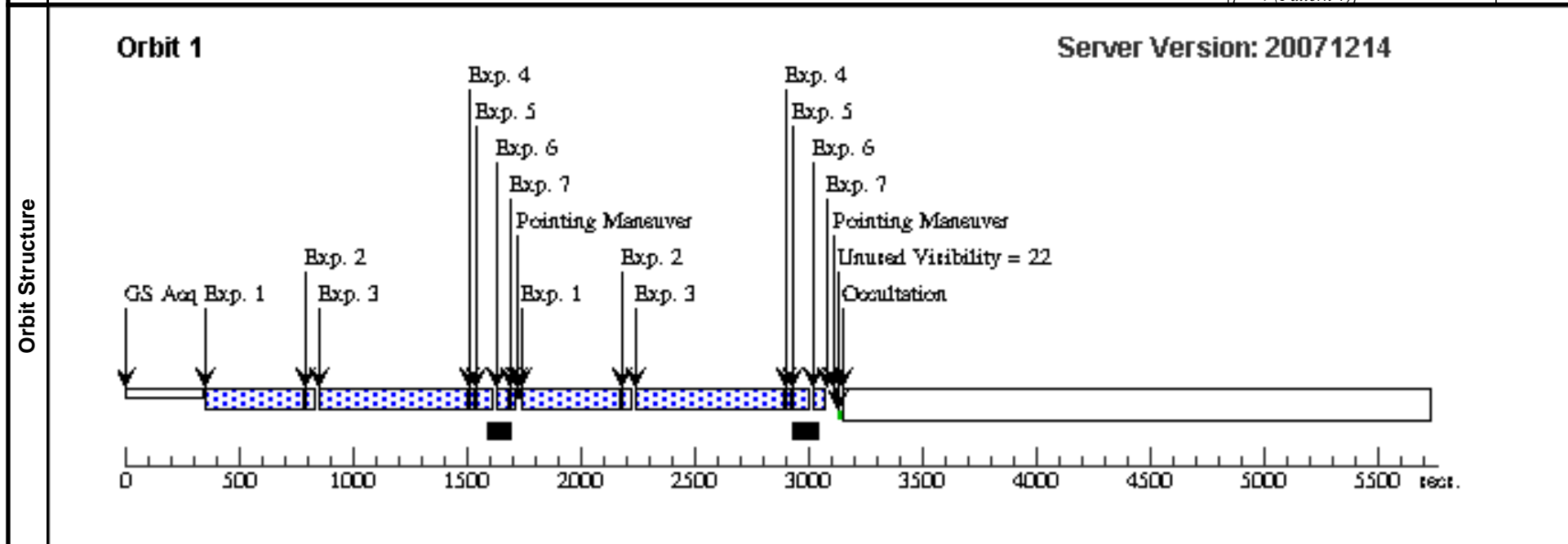

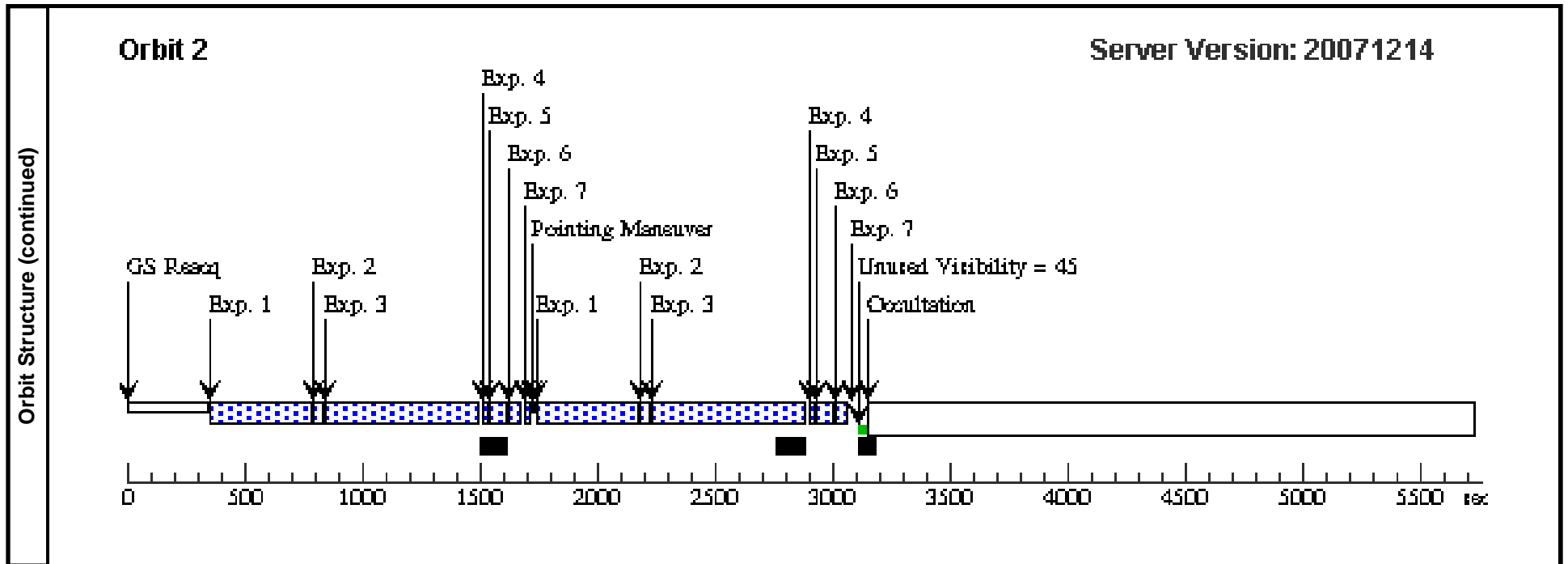

Proposal 11136 - Visit 08 - Resolving Ultracool Astrophysics with Brown Dwarf Binaries

Fri Jan 18 02:57:35 GMT 2008

Visit	Proposal 11136, Visit 08 Diagnostic Status: No Diagnostics Scientific Instruments: NIC1 Special Requirements: (none)									
	Patterns	#	Primary Pattern	Secondary Pattern	Exposures					
	(3)	Pattern Type=NIC-SPIRAL-DITH Purpose=DITHER Number Of Points=4 Point Spacing=1.304 Line Spacing=	Coordinate Frame=POS-TARG Pattern Orientation=0.0 Angle Between Sides= Center Pattern=false		(1-7)					
Fixed Targets	#	Name	Target Coordinates	Targ. Coord. Corrections	Fluxes	Miscellaneous				
	(8)	SDSS1052+44	RA: 10 52 13.5000 (163.0562500d) Dec: +44 22 55.90 (44.38219d) Equinox: J2000	Proper Motion RA: 0.0008s/yr Proper Motion Dec: -0.056"/yr Epoch of Position: 1998.323	V=25 J=15.9	Reference Frame: ICRS				
Exposures	#	Label	Target	Config,Mode,Aperture	Spectral Els.	Opt. Params.	Special Reqs.	Groups	Exp. Time/[Actual Dur.]	Orbit
	1		(8) SDSS1052+44	NIC1, MULTIACCUM, NIC1	F090M	SAMP-SEQ=STEP3 2; NSAMP=20		Pattern 1-7 (3)	[==>(Pattern 1)]	[1]
									[==>(Pattern 2)]	
									[==>(Pattern 3)]	[2]
									[==>(Pattern 4)]	
	2		(8) SDSS1052+44	NIC1, MULTIACCUM, NIC1	F110M	SAMP-SEQ=STEP1 6; NSAMP=8		Pattern 1-7 (3)	[==>(Pattern 1)]	[1]
									[==>(Pattern 2)]	
									[==>(Pattern 3)]	[2]
									[==>(Pattern 4)]	
	3		(8) SDSS1052+44	NIC1, MULTIACCUM, NIC1	F108N	SAMP-SEQ=STEP1 28; NSAMP=14		Pattern 1-7 (3)	[==>(Pattern 1)]	[1]
									[==>(Pattern 2)]	
									[==>(Pattern 3)]	[2]
									[==>(Pattern 4)]	
	4		(8) SDSS1052+44	NIC1, MULTIACCUM, NIC1	F160W	SAMP-SEQ=STEP2 ; NSAMP=9		Pattern 1-7 (3)	[==>(Pattern 1)]	[1]
									[==>(Pattern 2)]	
								[==>(Pattern 3)]	[2]	
								[==>(Pattern 4)]		
5		(8) SDSS1052+44	NIC1, MULTIACCUM, NIC1	F145M	SAMP-SEQ=STEP3 2; NSAMP=9		Pattern 1-7 (3)	[==>(Pattern 1)]	[1]	
								[==>(Pattern 2)]		
								[==>(Pattern 3)]	[2]	
								[==>(Pattern 4)]		

Proposal 11136 - Visit 08 - Resolving Ultracool Astrophysics with Brown Dwarf Binaries

Exposures (continued)	#	Label	Target	Config, Mode, Aperture	Spectral Els.	Opt. Params.	Special Reqs.	Groups	Exp. Time/[Actual Dur.]	Orbit
	6		(8) SDSS1052+44	NIC1, MULTIACCUM, NIC1	F170M	SAMP-SEQ=STEP8 ; NSAMP=10		Pattern 1-7 (3)	[==>(Pattern 1)] [==>(Pattern 2)] [==>(Pattern 3)] [==>(Pattern 4)]	[1] [2]
7		(8) SDSS1052+44	NIC1, MULTIACCUM, NIC1	F110W	SAMP-SEQ=STEP8 ; NSAMP=6		Pattern 1-7 (3)	[==>(Pattern 1)] [==>(Pattern 2)] [==>(Pattern 3)] [==>(Pattern 4)]	[1] [2]	

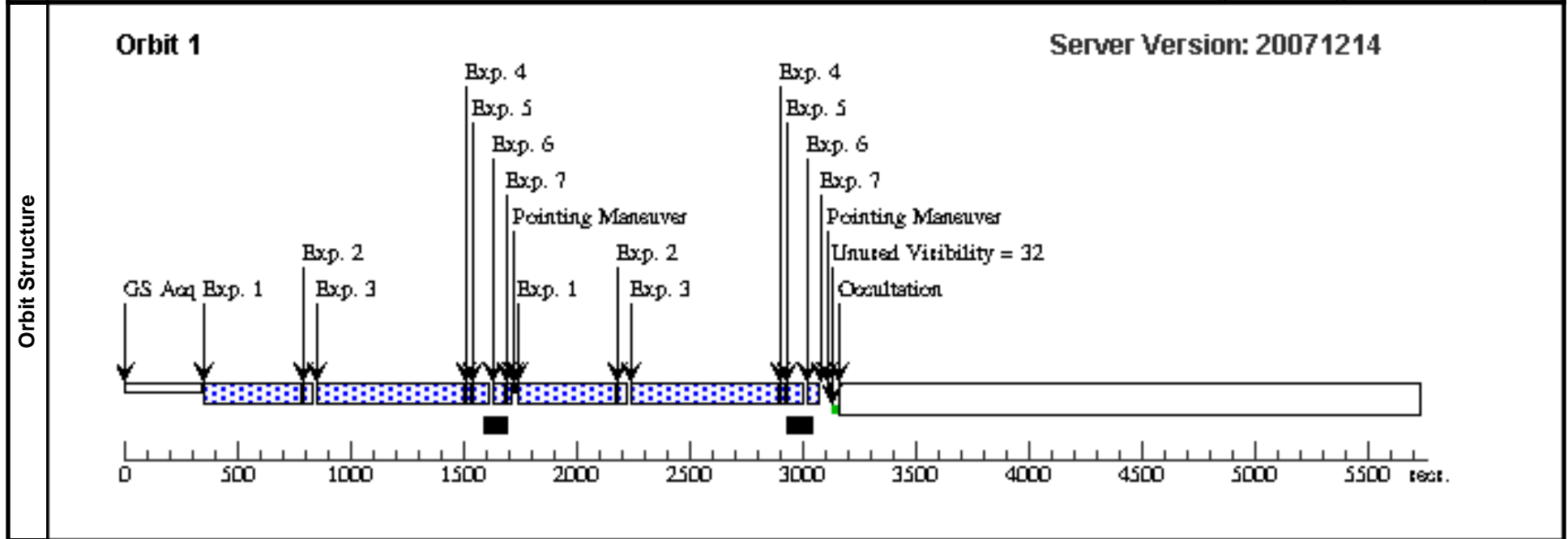

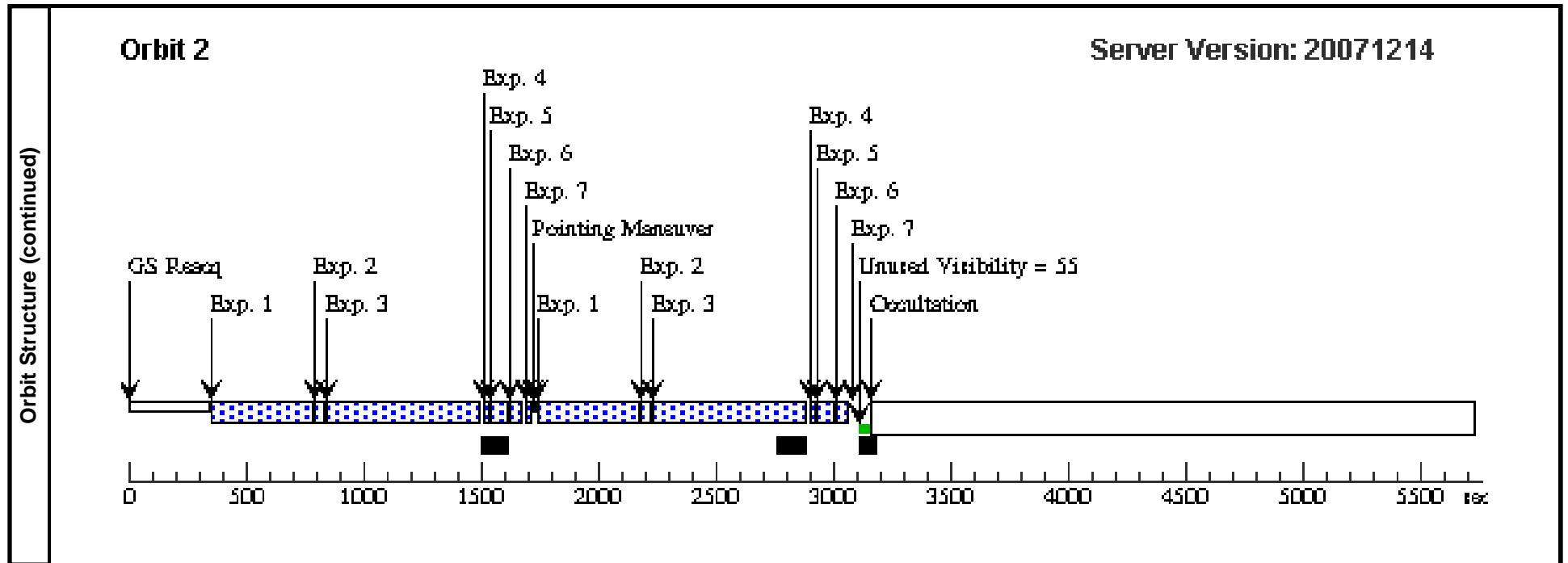

Proposal 11136 - Visit 09 - Resolving Ultracool Astrophysics with Brown Dwarf Binaries

Fri Jan 18 02:57:35 GMT 2008

Visit	Proposal 11136, Visit 09, implementation Diagnostic Status: No Diagnostics Scientific Instruments: NIC1 Special Requirements: (none)									
	Patterns	#	Primary Pattern		Secondary Pattern	Exposures				
(2)		Pattern Type=NIC-SPIRAL-DITH Purpose=DITHER Number Of Points=5 Point Spacing=1.304 Line Spacing=	Coordinate Frame=POS-TARG Pattern Orientation=0.0 Angle Between Sides= Center Pattern=false		(6-7)					
(3)		Pattern Type=NIC-SPIRAL-DITH Purpose=DITHER Number Of Points=4 Point Spacing=1.304 Line Spacing=	Coordinate Frame=POS-TARG Pattern Orientation=0.0 Angle Between Sides= Center Pattern=false		(1-5)					
Fixed Targets	#	Name	Target Coordinates	Targ. Coord. Corrections	Fluxes	Miscellaneous				
	(7)	SDSS1021-03AB	RA: 10 21 9.6900 (155.2903750d) Dec: -03 04 19.70 (-3.07214d) Equinox: J2000	Proper Motion RA: -0.0114s/yr Proper Motion Dec: -0.066"/yr Parallax: 0.0344" Epoch of Position: 1998.934	V=25 J=16.2	Reference Frame: ICRS				
Exposures	#	Label	Target	Config,Mode,Aperture	Spectral Els.	Opt. Params.	Special Reqs.	Groups	Exp. Time/[Actual Dur.]	Orbit
	1		(7) SDSS1021-03AB	NIC1, MULTIACCUM, NIC1	F090M	SAMP-SEQ=STEP6 4; NSAMP=17		Pattern 1-5 (3)	[==>(Pattern 1)] [==>(Pattern 2)] [==>(Pattern 3)] [==>(Pattern 4)]	[1] [2]
	2		(7) SDSS1021-03AB	NIC1, MULTIACCUM, NIC1	F110M	SAMP-SEQ=STEP1 6; NSAMP=9		Pattern 1-5 (3)	[==>(Pattern 1)] [==>(Pattern 2)] [==>(Pattern 3)] [==>(Pattern 4)]	[1] [2]
	3		(7) SDSS1021-03AB	NIC1, MULTIACCUM, NIC1	F145M	SAMP-SEQ=STEP3 2; NSAMP=10		Pattern 1-5 (3)	[==>(Pattern 1)] [==>(Pattern 2)] [==>(Pattern 3)] [==>(Pattern 4)]	[1] [2]

Proposal 11136 - Visit 09 - Resolving Ultracool Astrophysics with Brown Dwarf Binaries

Exposures (continued)	#	Label	Target	Config,Mode,Aperture	Spectral Els.	Opt. Params.	Special Reqs.	Groups	Exp. Time/[Actual Dur.]	Orbit
	4	(7) SDSS1021-03AB	NIC1, MULTIACCUM, NIC1	F170M	SAMP-SEQ=STEP8 ; NSAMP=12		Pattern 1-5 (3)	[==>(Pattern 1)] [==>(Pattern 2)] [==>(Pattern 3)] [==>(Pattern 4)]	[1] [2]	
	5	(7) SDSS1021-03AB	NIC1, MULTIACCUM, NIC1	F110W	SAMP-SEQ=STEP2 ; NSAMP=9		Pattern 1-5 (3)	[==>(Pattern 1)] [==>(Pattern 2)] [==>(Pattern 3)] [==>(Pattern 4)]	[1] [2]	
	6	(7) SDSS1021-03AB	NIC1, MULTIACCUM, NIC1	F108N	SAMP-SEQ=STEP6 4; NSAMP=21		Pattern 6-7 (2)	[==>(Pattern 1)] [==>(Pattern 2)] [==>(Pattern 3)] [==>(Pattern 4)] [==>(Pattern 5)]	[2] [3]	
	7	(7) SDSS1021-03AB	NIC1, MULTIACCUM, NIC1	F160W	SAMP-SEQ=STEP8 ; NSAMP=8		Pattern 6-7 (2)	[==>(Pattern 1)] [==>(Pattern 2)] [==>(Pattern 3)] [==>(Pattern 4)] [==>(Pattern 5)]	[2] [3]	

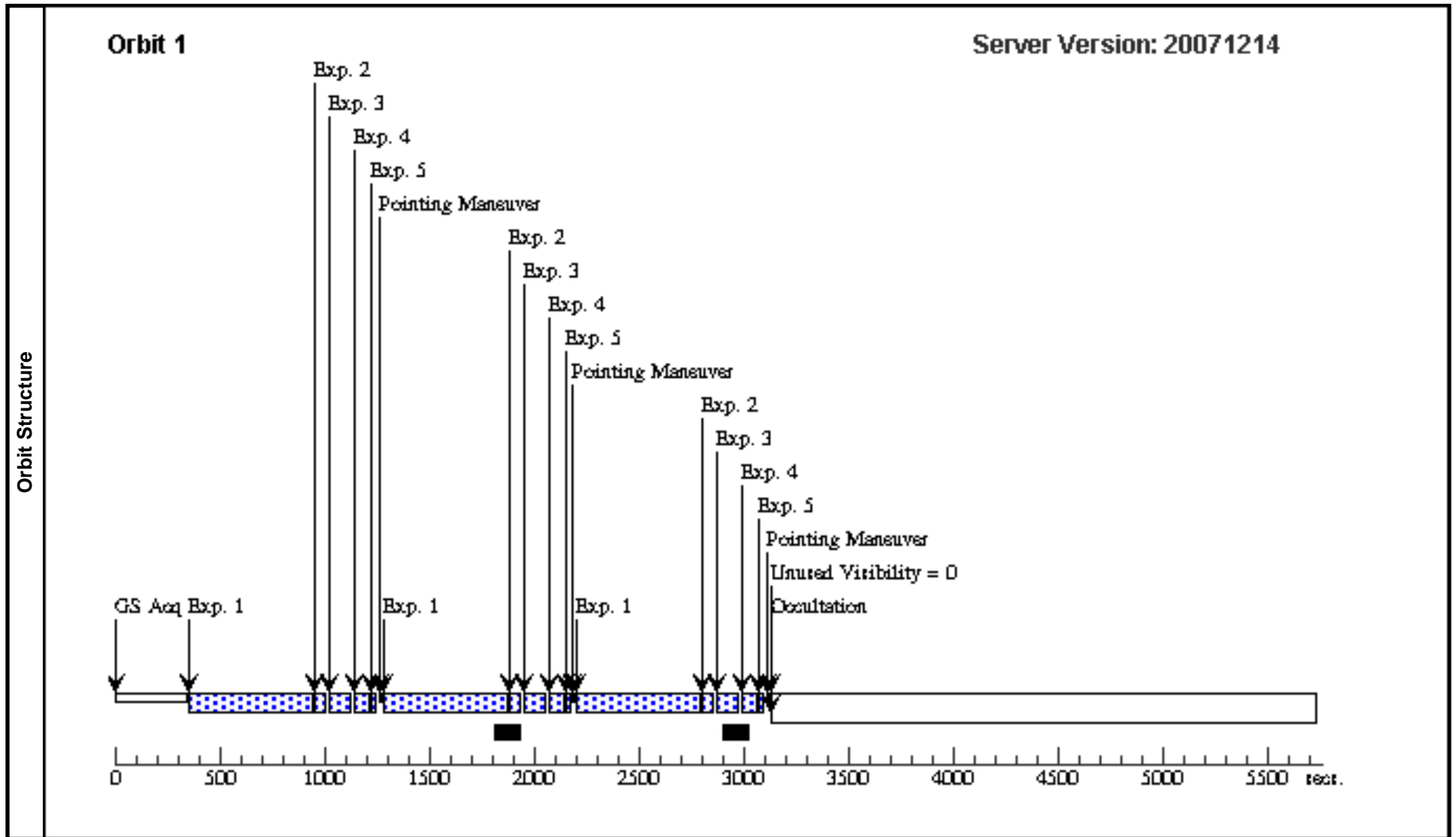

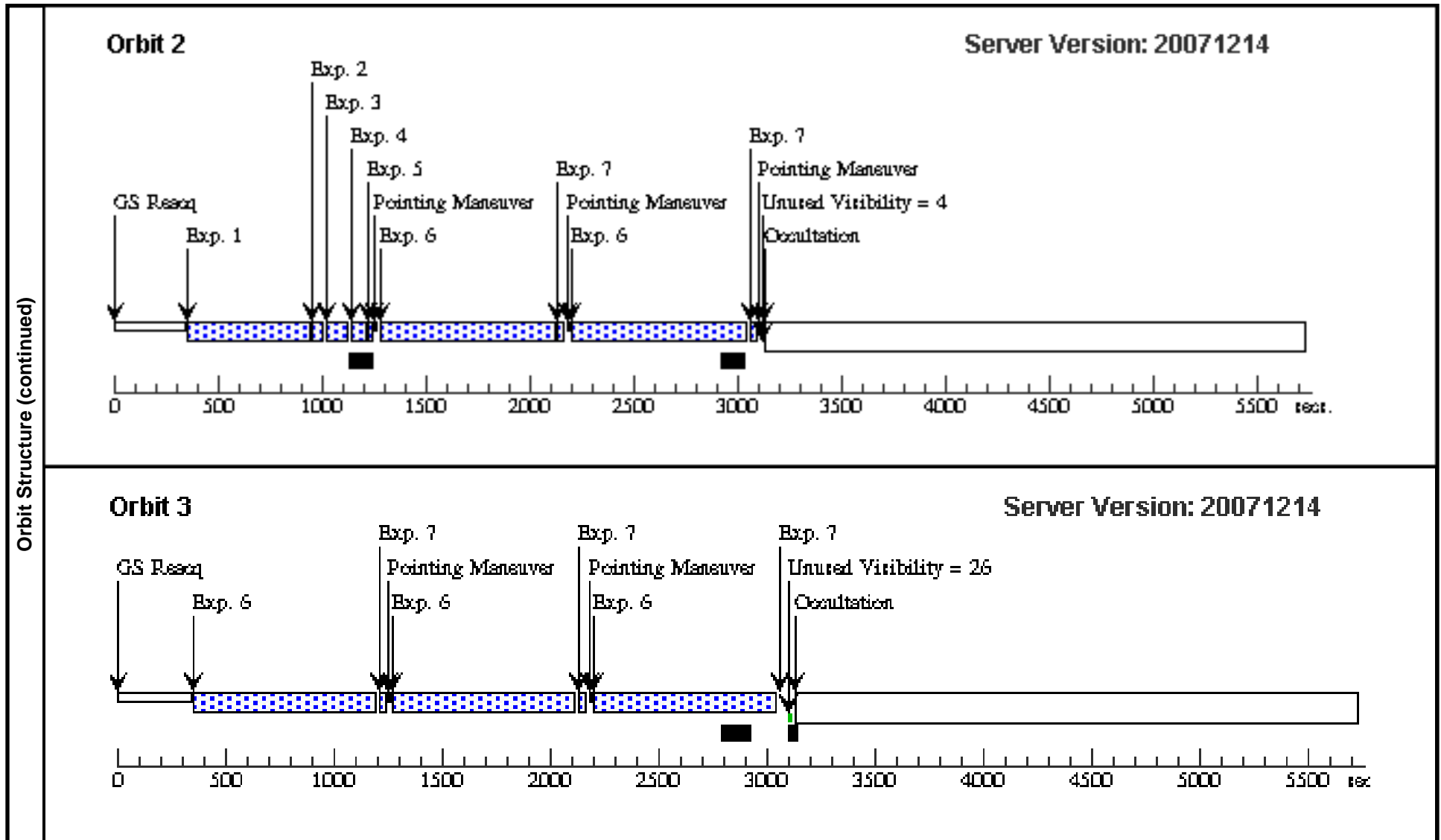

Proposal 11136 - Visit 10 - Resolving Ultracool Astrophysics with Brown Dwarf Binaries

Fri Jan 18 02:57:36 GMT 2008

Visit	Proposal 11136, Visit 10 Diagnostic Status: No Diagnostics Scientific Instruments: NIC1 Special Requirements: (none)									
	Patterns	#	Primary Pattern	Secondary Pattern	Exposures					
		(2)	Pattern Type=NIC-SPIRAL-DITH Purpose=DITHER Number Of Points=5 Point Spacing=1.304 Line Spacing=	Coordinate Frame=POS-TARG Pattern Orientation=0.0 Angle Between Sides= Center Pattern=false		(6-7)				
	(3)	Pattern Type=NIC-SPIRAL-DITH Purpose=DITHER Number Of Points=4 Point Spacing=1.304 Line Spacing=	Coordinate Frame=POS-TARG Pattern Orientation=0.0 Angle Between Sides= Center Pattern=false		(1-5)					
Fixed Targets	#	Name	Target Coordinates	Targ. Coord. Corrections	Fluxes	Miscellaneous				
	(9)	SDSS1534+16	RA: 15 34 17.1100 (233.5712917d) Dec: +16 15 46.30 (16.26286d) Equinox: J2000	Proper Motion RA: -0.0105s/yr Proper Motion Dec: -0.05"/yr Epoch of Position: 1999.225	V=25 J=16.7	Reference Frame: ICRS				
Exposures	#	Label	Target	Config,Mode,Aperture	Spectral Els.	Opt. Params.	Special Reqs.	Groups	Exp. Time/[Actual Dur.]	Orbit
	1		(9) SDSS1534+16	NIC1, MULTIACCUM, NIC1	F090M	SAMP-SEQ=STEP6 4; NSAMP=17			Pattern 1-5 (3)	[==>(Pattern 1)] [==>(Pattern 2)] [==>(Pattern 3)] [==>(Pattern 4)]
2		(9) SDSS1534+16	NIC1, MULTIACCUM, NIC1	F110M	SAMP-SEQ=STEP1 6; NSAMP=9			Pattern 1-5 (3)	[==>(Pattern 1)] [==>(Pattern 2)] [==>(Pattern 3)] [==>(Pattern 4)]	[1] [2]
3		(9) SDSS1534+16	NIC1, MULTIACCUM, NIC1	F145M	SAMP-SEQ=STEP3 2; NSAMP=10			Pattern 1-5 (3)	[==>(Pattern 1)] [==>(Pattern 2)] [==>(Pattern 3)] [==>(Pattern 4)]	[1] [2]

Proposal 11136 - Visit 10 - Resolving Ultracool Astrophysics with Brown Dwarf Binaries

Exposures (continued)	#	Label	Target	Config,Mode,Aperture	Spectral Els.	Opt. Params.	Special Reqs.	Groups	Exp. Time/[Actual Dur.]	Orbit
	4		(9) SDSS1534+16	NIC1, MULTIACCUM, NIC1	F170M	SAMP-SEQ=STEP8 ; NSAMP=12		Pattern 1-5 (3)	[==>(Pattern 1)] [==>(Pattern 2)] [==>(Pattern 3)] [==>(Pattern 4)]	[1] [2]
	5		(9) SDSS1534+16	NIC1, MULTIACCUM, NIC1	F110W	SAMP-SEQ=STEP2 ; NSAMP=9		Pattern 1-5 (3)	[==>(Pattern 1)] [==>(Pattern 2)] [==>(Pattern 3)] [==>(Pattern 4)]	[1] [2]
	6		(9) SDSS1534+16	NIC1, MULTIACCUM, NIC1	F108N	SAMP-SEQ=STEP6 4; NSAMP=21		Pattern 6-7 (2)	[==>(Pattern 1)] [==>(Pattern 2)] [==>(Pattern 3)] [==>(Pattern 4)] [==>(Pattern 5)]	[2] [3]
	7		(9) SDSS1534+16	NIC1, MULTIACCUM, NIC1	F160W	SAMP-SEQ=STEP8 ; NSAMP=8		Pattern 6-7 (2)	[==>(Pattern 1)] [==>(Pattern 2)] [==>(Pattern 3)] [==>(Pattern 4)] [==>(Pattern 5)]	[2] [3]

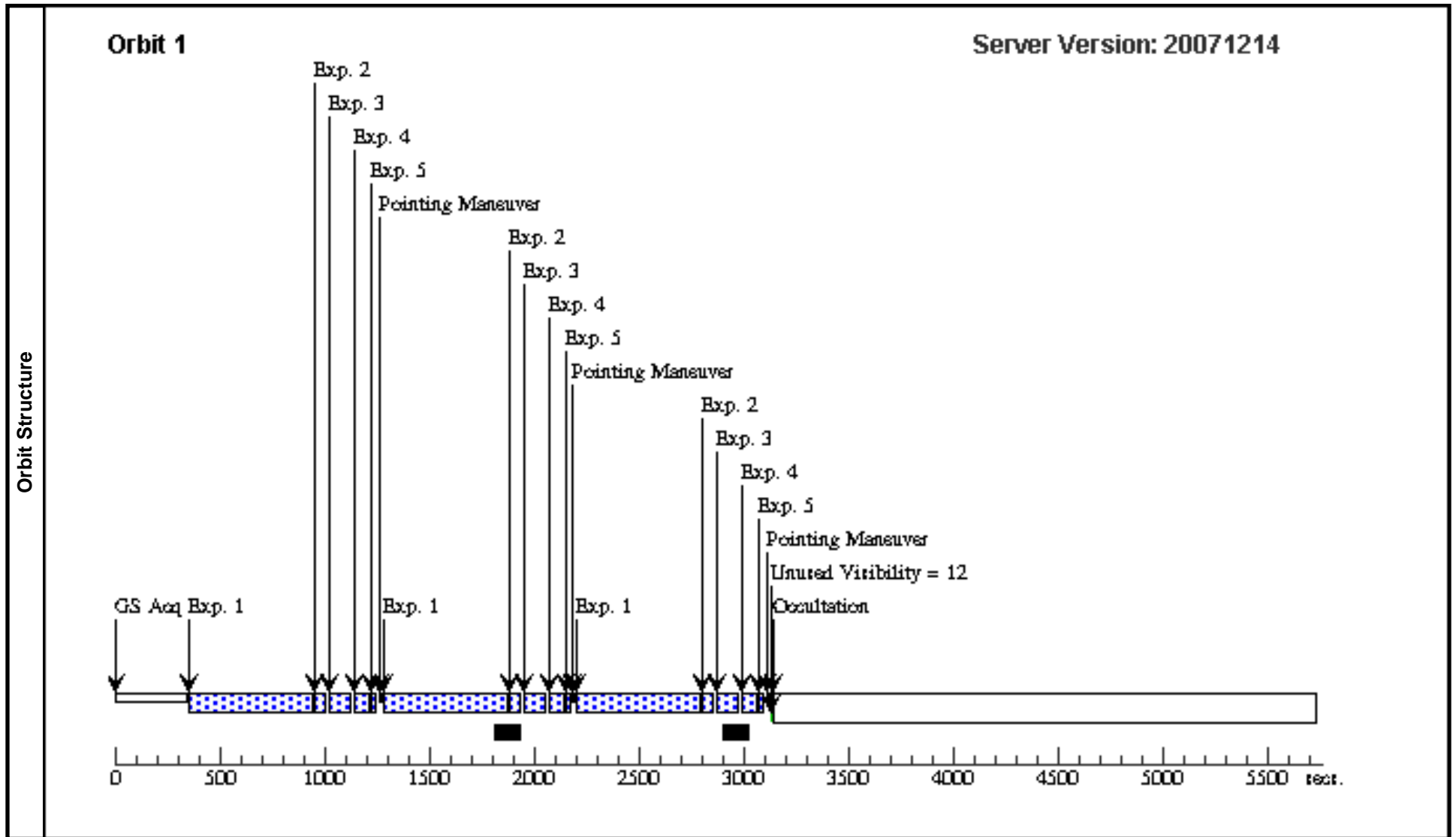

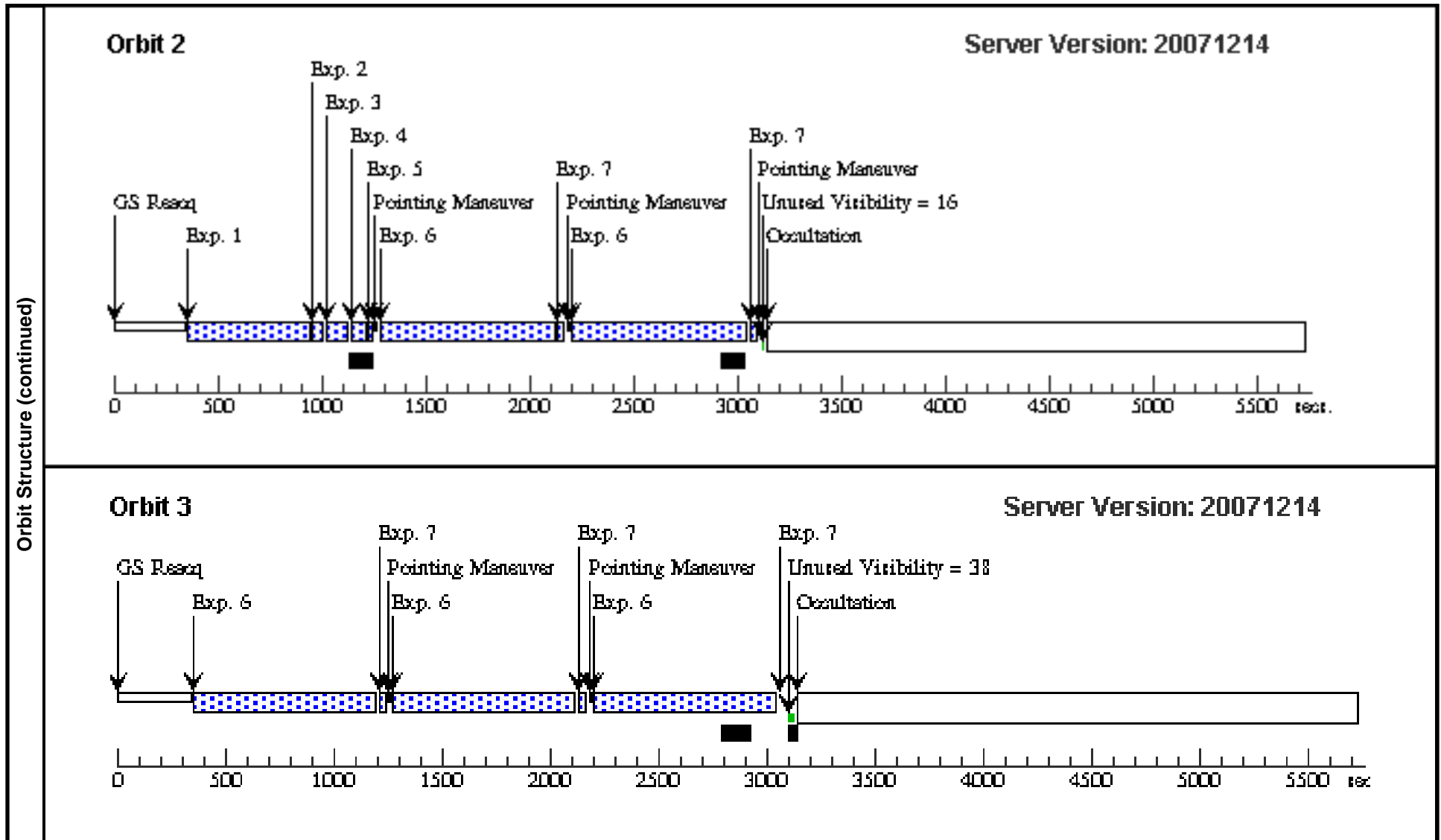

Proposal 11136 - Visit 11 - Resolving Ultracool Astrophysics with Brown Dwarf Binaries

Fri Jan 18 02:57:37 GMT 2008

Visit	Proposal 11136, Visit 11 Diagnostic Status: No Diagnostics Scientific Instruments: NIC1 Special Requirements: (none)									
	Patterns	#	Primary Pattern	Secondary Pattern	Exposures					
		(2)	Pattern Type=NIC-SPIRAL-DITH Purpose=DITHER Number Of Points=5 Point Spacing=1.304 Line Spacing=	Coordinate Frame=POS-TARG Pattern Orientation=0.0 Angle Between Sides= Center Pattern=false		(6-7)				
	(3)	Pattern Type=NIC-SPIRAL-DITH Purpose=DITHER Number Of Points=4 Point Spacing=1.304 Line Spacing=	Coordinate Frame=POS-TARG Pattern Orientation=0.0 Angle Between Sides= Center Pattern=false		(1-5)					
Fixed Targets	#	Name	Target Coordinates	Targ. Coord. Corrections	Fluxes	Miscellaneous				
	(10)	2M1728+3948AB	RA: 17 28 11.5000 (262.0479167d) Dec: +39 48 59.30 (39.81647d) Equinox: J2000	Proper Motion RA: 0.0032s/yr Proper Motion Dec: -0.026"/yr Parallax: 0.04149" Epoch of Position: 1998.361	V=25 J=16.0	Reference Frame: ICRS				
Exposures	#	Label	Target	Config,Mode,Aperture	Spectral Els.	Opt. Params.	Special Reqs.	Groups	Exp. Time/[Actual Dur.]	Orbit
	1		(10) 2M1728+3948A B	NIC1, MULTIACCUM, NIC1	F090M	SAMP-SEQ=STEP6 4; NSAMP=17		Pattern 1-5 (3)	[==>(Pattern 1)] [==>(Pattern 2)] [==>(Pattern 3)] [==>(Pattern 4)]	[1] [2]
2		(10) 2M1728+3948A B	NIC1, MULTIACCUM, NIC1	F110M	SAMP-SEQ=STEP1 6; NSAMP=9		Pattern 1-5 (3)	[==>(Pattern 1)] [==>(Pattern 2)] [==>(Pattern 3)] [==>(Pattern 4)]	[1] [2]	
3		(10) 2M1728+3948A B	NIC1, MULTIACCUM, NIC1	F145M	SAMP-SEQ=STEP3 2; NSAMP=10		Pattern 1-5 (3)	[==>(Pattern 1)] [==>(Pattern 2)] [==>(Pattern 3)] [==>(Pattern 4)]	[1] [2]	

Proposal 11136 - Visit 11 - Resolving Ultracool Astrophysics with Brown Dwarf Binaries

Exposures (continued)	#	Label	Target	Config,Mode,Aperture	Spectral Els.	Opt. Params.	Special Reqs.	Groups	Exp. Time/[Actual Dur.]	Orbit
	4		(10) 2M1728+3948A B	NIC1, MULTIACCUM, NIC1	F170M	SAMP-SEQ=STEP8 ; NSAMP=12		Pattern 1-5 (3)	[==>(Pattern 1)]	[1]
									[==>(Pattern 2)]	
									[==>(Pattern 3)]	
									[==>(Pattern 4)]	
5		(10) 2M1728+3948A B	NIC1, MULTIACCUM, NIC1	F110W	SAMP-SEQ=STEP2 ; NSAMP=9		Pattern 1-5 (3)	[==>(Pattern 1)]	[1]	
								[==>(Pattern 2)]		
								[==>(Pattern 3)]		
								[==>(Pattern 4)]		[2]
6		(10) 2M1728+3948A B	NIC1, MULTIACCUM, NIC1	F108N	SAMP-SEQ=STEP6 4; NSAMP=21		Pattern 6-7 (2)	[==>(Pattern 1)]	[2]	
								[==>(Pattern 2)]		
								[==>(Pattern 3)]		
								[==>(Pattern 4)]		[3]
[==>(Pattern 5)]										
7		(10) 2M1728+3948A B	NIC1, MULTIACCUM, NIC1	F160W	SAMP-SEQ=STEP8 ; NSAMP=8		Pattern 6-7 (2)	[==>(Pattern 1)]	[2]	
								[==>(Pattern 2)]		
								[==>(Pattern 3)]		
								[==>(Pattern 4)]		[3]
[==>(Pattern 5)]										

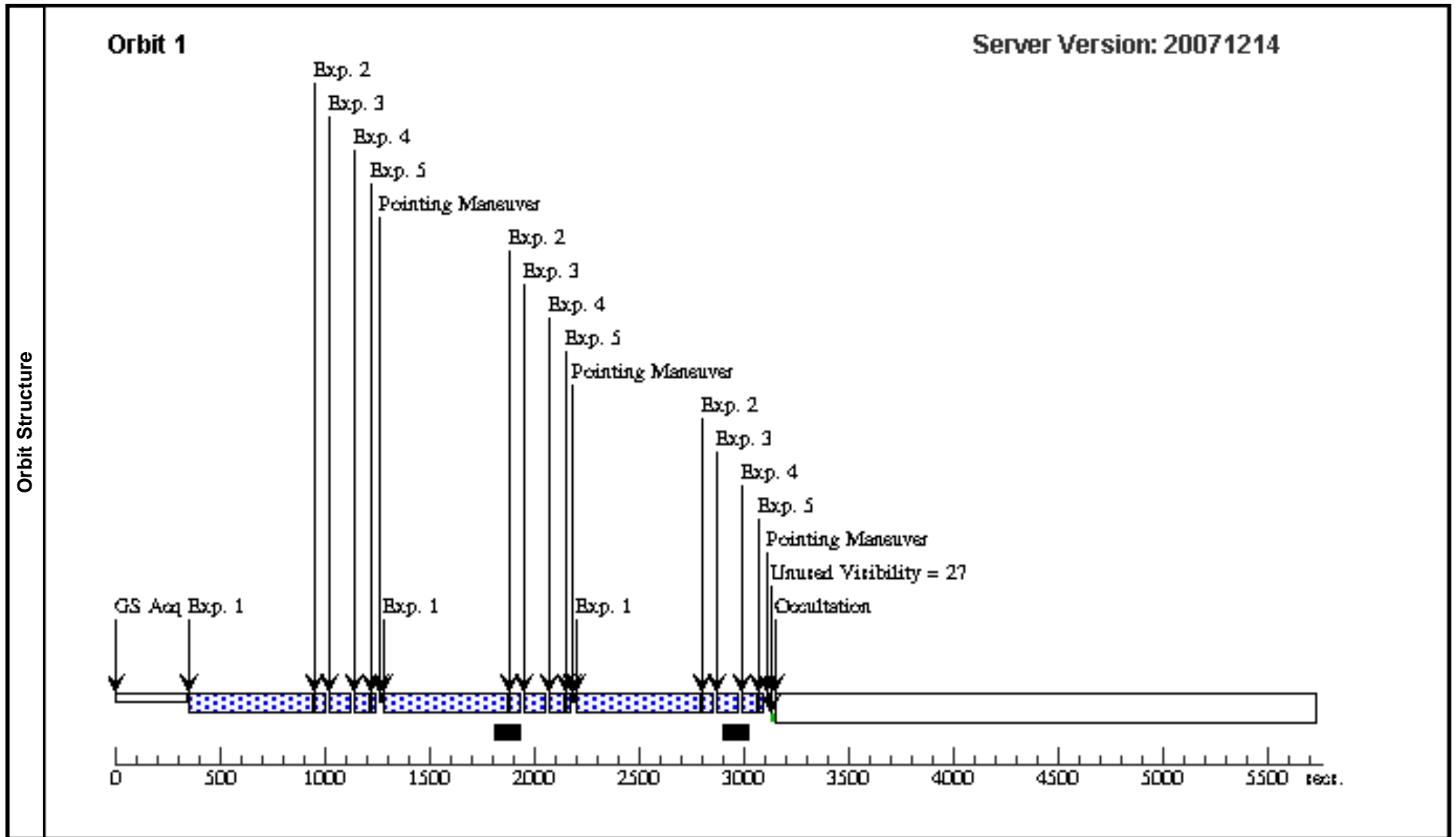

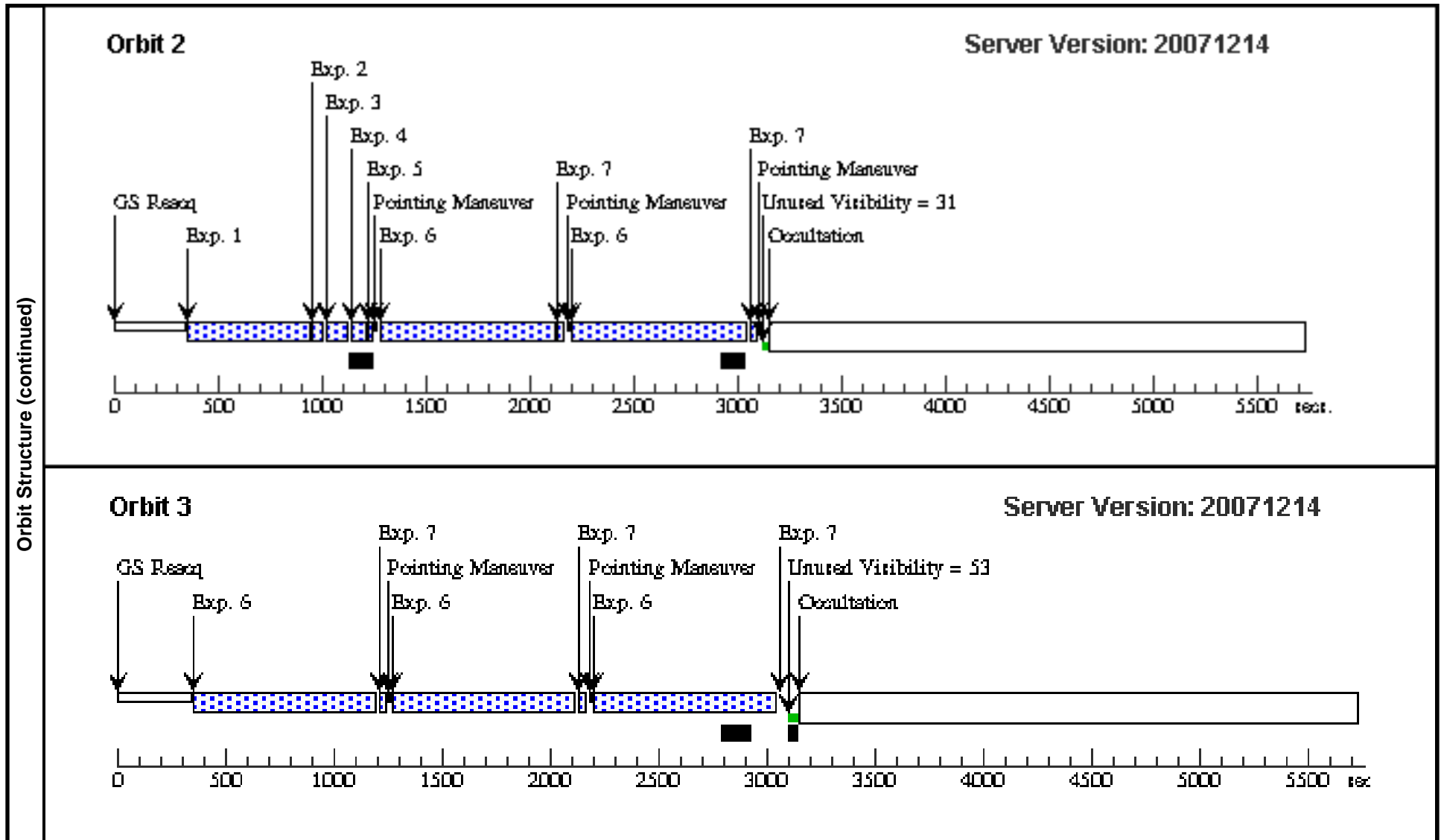

Proposal 11136 - Visit 12 - Resolving Ultracool Astrophysics with Brown Dwarf Binaries

Fri Jan 18 02:57:37 GMT 2008

Visit	Proposal 11136, Visit 12 Diagnostic Status: No Diagnostics Scientific Instruments: NIC1 Special Requirements: (none)									
	Patterns	#	Primary Pattern	Secondary Pattern	Exposures					
		(2)	Pattern Type=NIC-SPIRAL-DITH Purpose=DITHER Number Of Points=5 Point Spacing=1.304 Line Spacing=	Coordinate Frame=POS-TARG Pattern Orientation=0.0 Angle Between Sides= Center Pattern=false		(6-7)				
	(3)	Pattern Type=NIC-SPIRAL-DITH Purpose=DITHER Number Of Points=4 Point Spacing=1.304 Line Spacing=	Coordinate Frame=POS-TARG Pattern Orientation=0.0 Angle Between Sides= Center Pattern=false		(1-5)					
Fixed Targets	#	Name	Target Coordinates	Targ. Coord. Corrections	Fluxes	Miscellaneous				
	(11)	SDSS2052-16	RA: 20 52 35.1500 (313.1464583d) Dec: -16 09 30.80 (-16.15856d) Equinox: J2000	Proper Motion RA: 0.0246s/yr Proper Motion Dec: 0.165"/yr Epoch of Position: 1999.416	V=25 J=16.2	Reference Frame: ICRS				
Exposures	#	Label	Target	Config,Mode,Aperture	Spectral Els.	Opt. Params.	Special Reqs.	Groups	Exp. Time/[Actual Dur.]	Orbit
	1		(11) SDSS2052-16	NIC1, MULTIACCUM, NIC1	F090M	SAMP-SEQ=STEP6 4; NSAMP=17			Pattern 1-5 (3)	[==>(Pattern 1)] [==>(Pattern 2)] [==>(Pattern 3)] [==>(Pattern 4)]
2		(11) SDSS2052-16	NIC1, MULTIACCUM, NIC1	F110M	SAMP-SEQ=STEP1 6; NSAMP=9			Pattern 1-5 (3)	[==>(Pattern 1)] [==>(Pattern 2)] [==>(Pattern 3)] [==>(Pattern 4)]	[1] [2]
3		(11) SDSS2052-16	NIC1, MULTIACCUM, NIC1	F145M	SAMP-SEQ=STEP3 2; NSAMP=10			Pattern 1-5 (3)	[==>(Pattern 1)] [==>(Pattern 2)] [==>(Pattern 3)] [==>(Pattern 4)]	[1] [2]

Proposal 11136 - Visit 12 - Resolving Ultracool Astrophysics with Brown Dwarf Binaries

Exposures (continued)	#	Label	Target	Config,Mode,Aperture	Spectral Els.	Opt. Params.	Special Reqs.	Groups	Exp. Time/[Actual Dur.]	Orbit
	4		(11) SDSS2052-16	NIC1, MULTIACCUM, NIC1	F170M	SAMP-SEQ=STEP8 ; NSAMP=12		Pattern 1-5 (3)	[==>(Pattern 1)] [==>(Pattern 2)] [==>(Pattern 3)] [==>(Pattern 4)]	[1] [2]
	5		(11) SDSS2052-16	NIC1, MULTIACCUM, NIC1	F110W	SAMP-SEQ=STEP2 ; NSAMP=9		Pattern 1-5 (3)	[==>(Pattern 1)] [==>(Pattern 2)] [==>(Pattern 3)] [==>(Pattern 4)]	[1] [2]
	6		(11) SDSS2052-16	NIC1, MULTIACCUM, NIC1	F108N	SAMP-SEQ=STEP6 4; NSAMP=21		Pattern 6-7 (2)	[==>(Pattern 1)] [==>(Pattern 2)] [==>(Pattern 3)] [==>(Pattern 4)] [==>(Pattern 5)]	[2] [3]
	7		(11) SDSS2052-16	NIC1, MULTIACCUM, NIC1	F160W	SAMP-SEQ=STEP8 ; NSAMP=8		Pattern 6-7 (2)	[==>(Pattern 1)] [==>(Pattern 2)] [==>(Pattern 3)] [==>(Pattern 4)] [==>(Pattern 5)]	[2] [3]

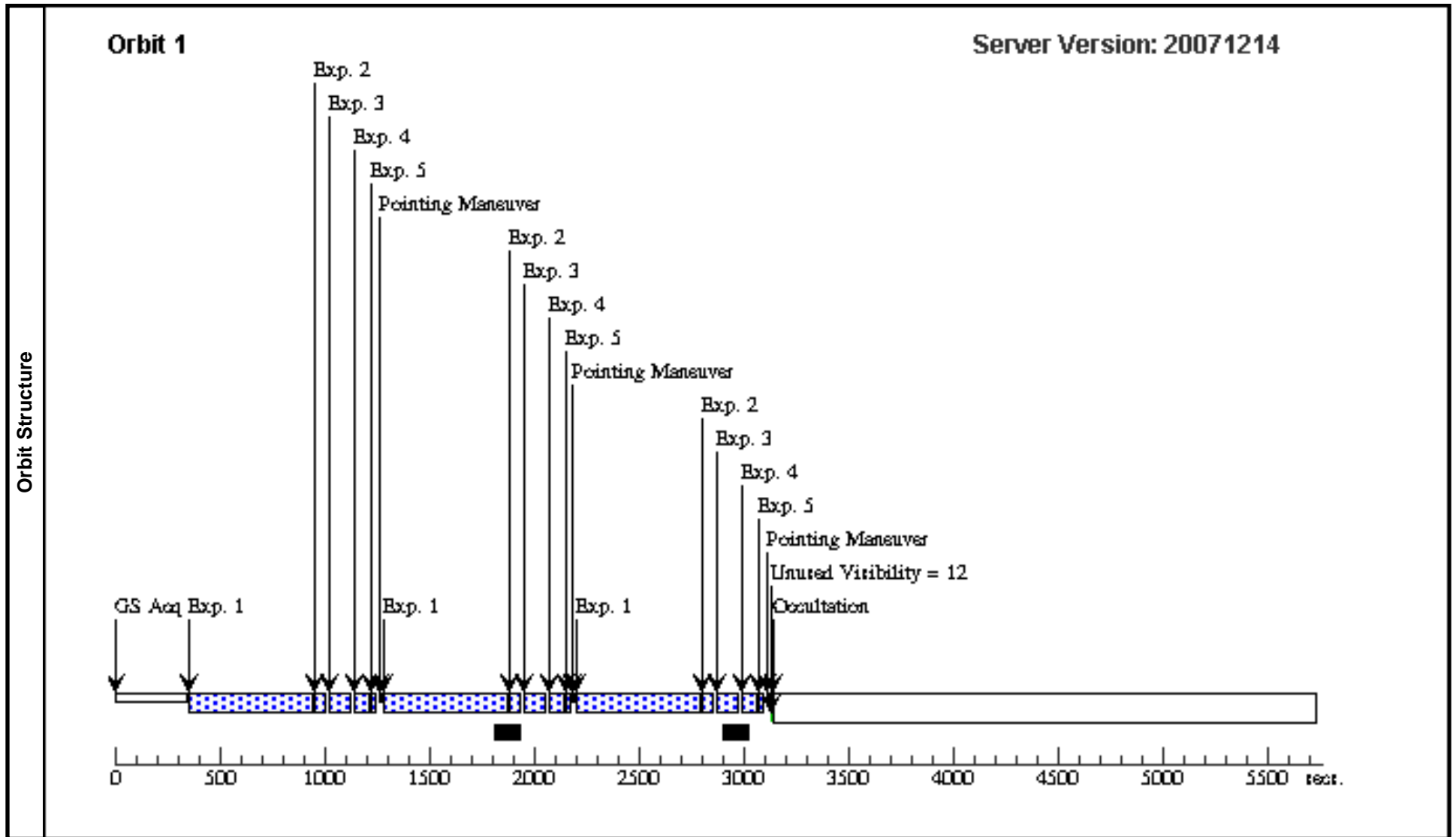

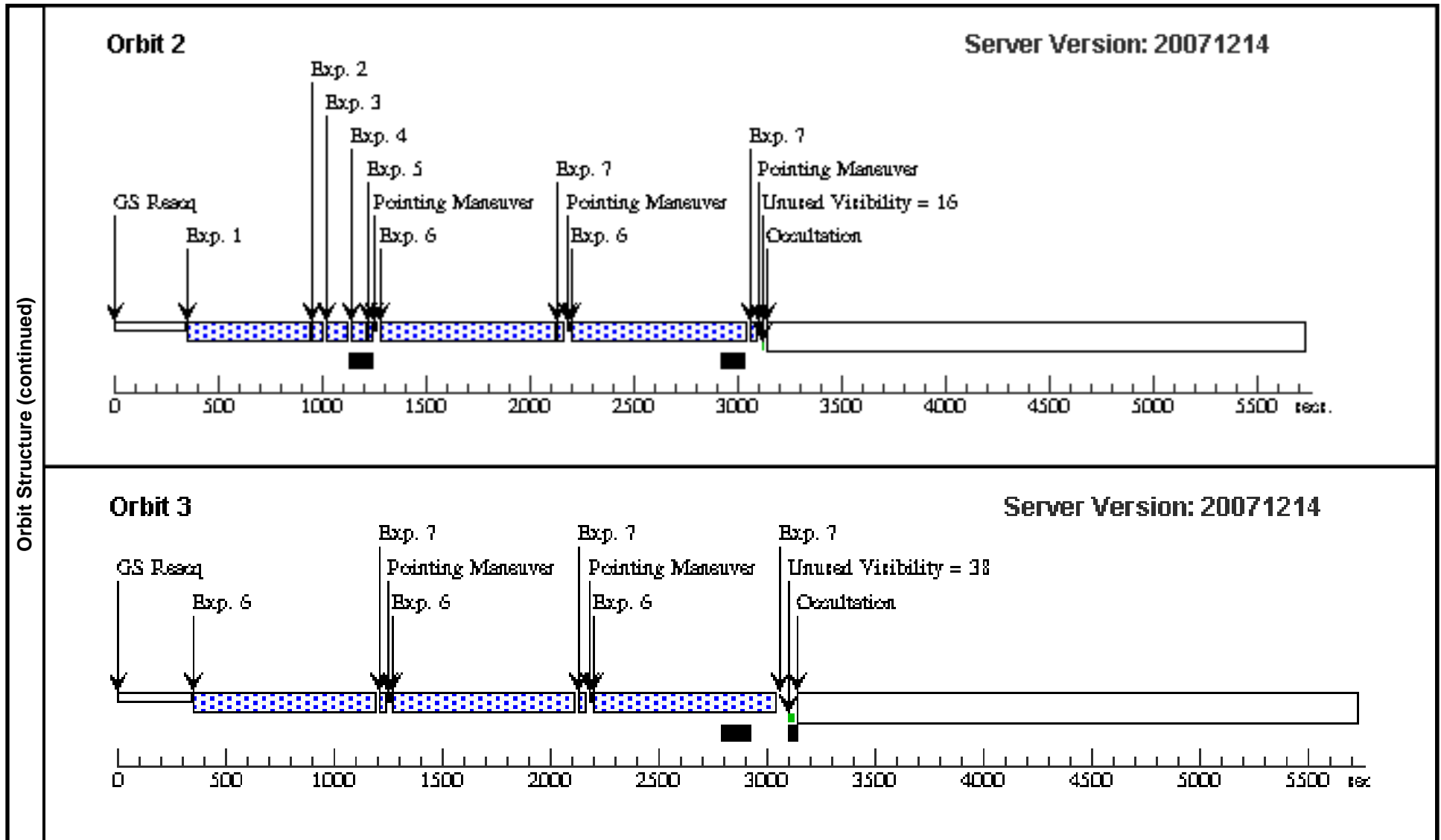

Proposal 11136 - Visit 13 - Resolving Ultracool Astrophysics with Brown Dwarf Binaries

Fri Jan 18 02:57:38 GMT 2008

Visit	Proposal 11136, Visit 13, implementation Diagnostic Status: No Diagnostics Scientific Instruments: NIC1 Special Requirements: (none)									
	Patterns	#	Primary Pattern	Secondary Pattern	Exposures					
	(4)	Pattern Type=NIC-SPIRAL-DITH Purpose=DITHER Number Of Points=3 Point Spacing=1.304 Line Spacing=	Coordinate Frame=POS-TARG Pattern Orientation=0.0 Angle Between Sides= Center Pattern=false		(1-6)					
Fixed Targets	#	Name	Target Coordinates	Targ. Coord. Corrections	Fluxes	Miscellaneous				
	(4)	2M0850+10AB	RA: 08 50 35.9300 (132.6497083d) Dec: +10 57 15.60 (10.95433d) Equinox: J2000	Proper Motion RA: -0.0099s/yr Proper Motion Dec: -0.019"/yr Parallax: 0.0391" Epoch of Position: 1997.877	V=25 J=16.5	Reference Frame: ICRS				
Exposures	#	Label	Target	Config,Mode,Aperture	Spectral Els.	Opt. Params.	Special Reqs.	Groups	Exp. Time/[Actual Dur.]	Orbit
	1	(4) 2M0850+10AB	NIC1, MULTIACCUM, NIC1	F090M	SAMP-SEQ=STEP6 4; NSAMP=17			Pattern 1-6 (4)	[==>(Pattern 1)] [==>(Pattern 2)] [==>(Pattern 3)]	[1]
	2	(4) 2M0850+10AB	NIC1, MULTIACCUM, NIC1	F110M	SAMP-SEQ=STEP1 6; NSAMP=10			Pattern 1-6 (4)	[==>(Pattern 1)] [==>(Pattern 2)] [==>(Pattern 3)]	[1]
	3	(4) 2M0850+10AB	NIC1, MULTIACCUM, NIC1	F145M	SAMP-SEQ=STEP8 ; NSAMP=12			Pattern 1-6 (4)	[==>(Pattern 1)] [==>(Pattern 2)] [==>(Pattern 3)]	[1]
	4	(4) 2M0850+10AB	NIC1, MULTIACCUM, NIC1	F170M	SAMP-SEQ=STEP1 6; NSAMP=8			Pattern 1-6 (4)	[==>(Pattern 1)] [==>(Pattern 2)] [==>(Pattern 3)]	[1]
	5	(4) 2M0850+10AB	NIC1, MULTIACCUM, NIC1	F110W	SAMP-SEQ=STEP8 ; NSAMP=8			Pattern 1-6 (4)	[==>(Pattern 1)] [==>(Pattern 2)] [==>(Pattern 3)]	[1]
	6	(4) 2M0850+10AB	NIC1, MULTIACCUM, NIC1	F160W	SAMP-SEQ=STEP8 ; NSAMP=7			Pattern 1-6 (4)	[==>(Pattern 1)] [==>(Pattern 2)] [==>(Pattern 3)]	[1]

