



# 11635 - In Search of SN Ib/Ic Wolf-Rayet Progenitors and Comparison with Red Supergiants (SN II Progenitors) in the Giant Sc I Spiral M101

Cycle: 17, Proposal Category: GO

(Large Program)

(Availability Mode: SUPPORTED)

## INVESTIGATORS

<i>Name</i>	<i>Institution</i>	<i>E-Mail</i>
<b>Dr. Michael Shara (PI)</b>	<b>American Museum of Natural History</b>	<b>mshara@amnh.org</b>
Dr. Anthony F.J. Moffat (CoI)	Universite de Montreal	moffat@astro.umontreal.ca
Dr. Laurent Drissen (CoI)	Universite Laval	ldrissen@phy.ulaval.ca
Dr. David R. Zurek (CoI)	American Museum of Natural History	dzurek@amnh.org
Dr. Paul Crowther (CoI) (ESA Member)	University of Sheffield	Paul.Crowther@sheffield.ac.uk
Dr. Lucy Hadfield (CoI)	Rochester Institute of Technology	hadfield@cis.rit.edu

## VISITS

<i>Visit</i>	<i>Targets used in Visit</i>	<i>Configurations used in Visit</i>	<i>Orbits Used</i>	<i>Last Orbit Planner Run</i>	<i>OP Current with Visit?</i>
01	(1) M101-A	WFC3/UVIS	2	16-Sep-2010 21:00:57.0	yes
02	(2) M101-B	WFC3/UVIS	2	16-Sep-2010 21:01:02.0	yes
03	(3) M101-C	WFC3/UVIS	2	16-Sep-2010 21:01:05.0	yes
04	(4) M101-D	WFC3/UVIS	2	16-Sep-2010 21:01:08.0	yes
05	(5) M101-E	WFC3/UVIS	2	16-Sep-2010 21:01:11.0	yes
06	(6) M101-F	WFC3/UVIS	2	16-Sep-2010 21:01:14.0	yes
07	(7) M101-G	WFC3/UVIS	2	16-Sep-2010 21:01:17.0	yes

<i>Visit</i>	<i>Targets used in Visit</i>	<i>Configurations used in Visit</i>	<i>Orbits Used</i>	<i>Last Orbit Planner Run</i>	<i>OP Current with Visit?</i>
08	(8) M101-H	WFC3/UVIS	2	16-Sep-2010 21:01:19.0	yes
09	(9) M101-I	WFC3/UVIS	2	16-Sep-2010 21:01:22.0	yes
10	(10) M101-J	WFC3/UVIS	2	16-Sep-2010 21:01:25.0	yes
11	(11) M101-K	WFC3/UVIS	2	16-Sep-2010 21:01:27.0	yes
12	(12) M101-L	WFC3/UVIS	2	16-Sep-2010 21:01:30.0	yes
13	(13) M101-M	WFC3/UVIS	2	16-Sep-2010 21:01:32.0	yes
14	(14) M101-N	WFC3/UVIS	2	16-Sep-2010 21:01:35.0	yes
15	(15) M101-O	WFC3/UVIS	2	16-Sep-2010 21:01:38.0	yes
16	(16) M101-P	WFC3/UVIS	2	16-Sep-2010 21:01:40.0	yes
17	(17) M101-Q	WFC3/UVIS	2	16-Sep-2010 21:01:42.0	yes
18	(18) M101-R	WFC3/UVIS	2	16-Sep-2010 21:01:45.0	yes

36 Total Orbits Used

## ABSTRACT

We propose to test two of the clearest predictions of the theory of evolution of massive-star evolution: 1) The formation of Wolf-Rayet stars depends strongly on these stars' metallicity ( $Z$ ), with relatively fewer WR stars forming at lower  $Z$ , and 2) Wolf-Rayet stars die as Type Ib or Ic supernovae. To carry out these tests we propose a deep, narrowband imaging survey of the massive star populations in the ScI spiral galaxy M101. Just as important, we will test the hypothesis that Superclusters like 30 Doradus are always richly populated with WR stars, and by implication that these complexes are responsible for the spectral signatures of starburst galaxies.

Our previous HST survey of the HII regions in the ScIII galaxy NGC 2403 suggested that the distribution of WR stars and RSG is a sensitive diagnostic of the recent star-forming history of these large complexes: young cores of O and WR stars are surrounded by older halos containing RSG. Theory predicts that this must change with metallicity; relatively fewer WR stars form at lower  $Z$ . A key goal of our proposal is to directly test this paradigm in a single galaxy, M101 being the ideal target. The abundance gradient across M101 (a factor of 20) suggests that relatively many more WR will be found in the inner parts of this galaxy than in the outer "suburbs". Second, we note that WR stars are predicted to end their lives as core-collapse or pair-instability supernovae. The WR population in M101 may be abundant enough for one to erupt as a Type Ib or Ic supernova within a generation. The clear a priori identification of a WR progenitor would be a major legacy of HST. Third, we will also determine if "superclusters",

heavily populated by WR stars, are common in M101. It is widely claimed that such Superclusters produce the integrated spectral signatures of Starburst galaxies. We will be able to directly measure the numbers and emission-line luminosities of thousands of Wolf Rayet stars located in hundreds of M101 Superclusters, and correlate those numbers against the Supercluster sizes and luminosities. It is likely (but far from certain) that Supercluster sizes and emission-line luminosities are driven by their Wolf-Rayet star content. Our sample will be the largest and best-ever Supercluster/Wolf Rayet sample, an excellent local proxy for characterizing starburst galaxies' Superclusters.

## **OBSERVING DESCRIPTION**

By far the easiest and most reliable technique to detect individual Wolf-Rayet stars in crowded fields, such as those in M101, consists of subtracting a normalized image in both psf and intensity continuum from an image obtained with a narrowband filter centered on the He II  $\lambda 4686$  line. This technique has been successfully used on images of nearby giant H II regions (Drissen, Moffat, & Shara 1993a). WFPC2 F469N (He II  $\lambda 4686$ ;  $3 \times 2000$  s) images of NGC 2403 were also successfully used to detect the signature of Wolf-Rayet stars. Two orbits that are NOT CVZ (with  $\sim 5000$  sec of total exposure time) permit us to image with  $S/N = 10$ , to  $m(469) = 26.0$  (the WFC3 ETC suggests that the HeII emission line is easily detected for the range of line strengths seen in WR stars at this exposure time) as effectively in M101 as we did to  $m(469) = 24.5$  in NGC 2403; i.e. we will go  $\sim 1.5$  magnitudes deeper with WFC3 in the same exposure time as with WFPC2, thus making up for the 4x greater distance to M101 than to NGC 2403. CVZ orbits will be a plus, but not essential for success.

We note here that the systemic redshift of M101 (+372 km/s) shifts the center of the He II  $\lambda 4686$  line to  $\sim 4692$  Å. This has virtually no effect on the detectability of WR stars in this galaxy, since the F469N filter transmission curve is fairly flat from 4680 to 4710 Å (centered at 4693 Å). This technique works well for individual WR stars with equivalent widths  $W_e(4686) \geq 10-15$  Å, and even for dense, unresolved clusters that include a very small fraction of WR stars. We will center WFC3 mostly on fields that already have deep continuum ACS images (F435W and F555W, or F555W and F814W, as shown in Figure 1 in Barmby et al 2006). A few images farther out (to reach a galacto-centric distance of 40 Kpc) will be coincident with archival HST WFPC2 continuum fields. Thus only the narrowband F469N imagery is required for this proposal.

Eighteen fields (2 orbits with F469N on each field) will cover 80% of the active star-forming surface area of M101 with spatially dense measurements of the WR/RSG ratio at all radial distances of 0-20 kpc, and sparser measurements out to 40kpc.

Red supergiant candidates will be detected in a (V, B-V) color-magnitude diagram of the region studied (see Figure 3 of Drissen et al 1999); they are

the stars at  $B-V \sim 2$  and  $V < 23$ . (We note that color alone is useless for finding WR stars.)

In addition, it is very informative to use a technique to discover RSG similar to that employed to detect WR stars: by subtracting a scaled B image from a V image, most stars disappear, but the reddest ones stand out. This is particularly useful in the most crowded areas. Fortunately all of these images already exist in the HST archives.

Finally, we note that 8m telescopes + Multi-Object-Spectrographs are providing spectral confirmation of the presence of WR stars in galaxies at distances equal to M101 (e.g. Crowther et al 2004 for M83). We will apply for Gemini time to spectrographically follow-up on the clusters richest in WR stars that we identify.

Proposal 11635 (STScI Edit Number: 5, Created: Thursday, September 16, 2010 8:01:48 PM EST) - Overview

Fri Sep 17 01:01:49 GMT 2010

<b>Visit</b>	<b>Proposal 11635, Visit 01, completed</b> <b>Diagnostic Status: Warning</b> Scientific Instruments: WFC3/UVIS Special Requirements: ORIENT 206.0D TO 214.0 D									
	(Visit 01) Warning (Orbit Planner): VISIBILITY OVERRUN (Visit 01) Warning (Orbit Planner): VISIBILITY OVERRUN									
<b>Diagnosics</b>										
<b>Patterns</b>	<b>#</b>	<b>Primary Pattern</b>			<b>Secondary Pattern</b>			<b>Exposures</b>		
	(1)	Pattern Type=WFC3-UVIS-DITHER-BOX Purpose=DITHER Number Of Points=4 Point Spacing=0.173 Line Spacing=0.112			Coordinate Frame=POS-TARG Pattern Orientation=23.884 Angle Between Sides=81.785 Center Pattern=false			(1)		
<b>Fixed Targets</b>	<b>#</b>	<b>Name</b>	<b>Target Coordinates</b>	<b>Targ. Coord. Corrections</b>	<b>Fluxes</b>	<b>Miscellaneous</b>				
	(1)	M101-A	RA: 14 02 50.4843 (210.7103512d) Dec: +54 27 25.11 (54.45698d) Equinox: J2000		V=25+/-0.1	Reference Frame: xdss				
<b>Exposures</b>	<b>#</b>	<b>Label</b>	<b>Target</b>	<b>Config,Mode,Aperture</b>	<b>Spectral Els.</b>	<b>Opt. Params.</b>	<b>Special Reqs.</b>	<b>Groups</b>	<b>Exp. Time/[Actual Dur.]</b>	<b>Orbit</b>
	1	(1) M101-A		WFC3/UVIS, ACCUM, UVIS-CENTER	F469N	CR-SPLIT=NO		Pattern 1, Exps 1-1 (1)	1492 Secs	
									[==>1492.0 Secs (Pattern 1)]	[1]
									[==>1492.0 Secs (Pattern 2)]	
								[==>1561.0 Secs (Pattern 3)]		
								[==>1561.0 Secs (Pattern 4)]	[2]	

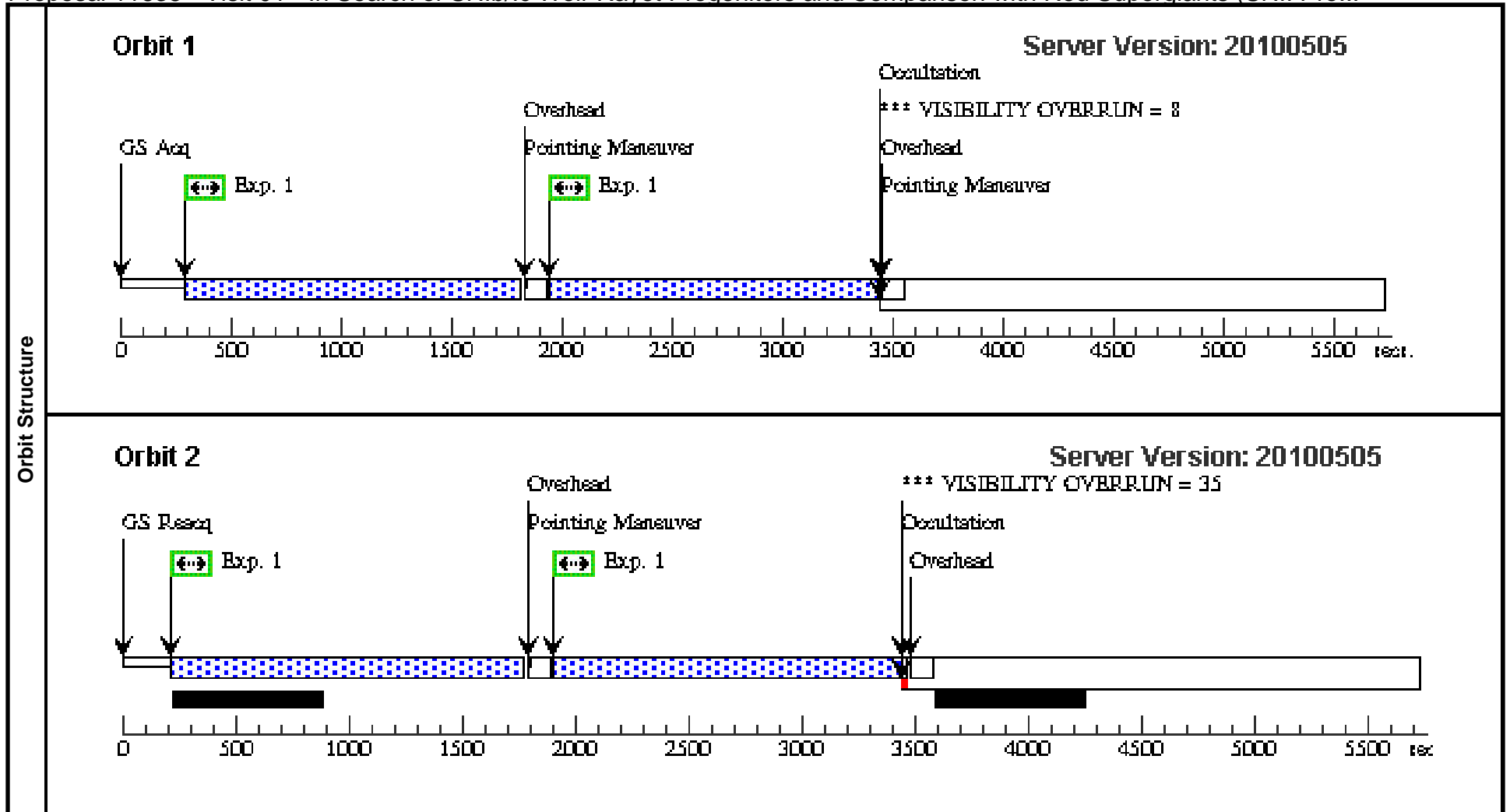

Proposal 11635 - Visit 01 - In Search of SNII/lc Wolf-Rayet Progenitors and Comparison with Red Supergiants (SNII Pro...

Fri Sep 17 01:01:49 GMT 2010

<b>Visit</b>	<b>Proposal 11635, Visit 02, completed</b> <b>Diagnostic Status: Warning</b> Scientific Instruments: WFC3/UVIS Special Requirements: ORIENT 206.0D TO 214.0 D										
	(Visit 02) Warning (Orbit Planner): VISIBILITY OVERRUN (Visit 02) Warning (Orbit Planner): VISIBILITY OVERRUN										
<b>Diagnosics</b>											
<b>Patterns</b>	<b>#</b>	<b>Primary Pattern</b>				<b>Secondary Pattern</b>				<b>Exposures</b>	
	(1)	Pattern Type=WFC3-UVIS-DITHER-BOX Purpose=DITHER Number Of Points=4 Point Spacing=0.173 Line Spacing=0.112				Coordinate Frame=POS-TARG Pattern Orientation=23.884 Angle Between Sides=81.785 Center Pattern=false				(1)	
<b>Fixed Targets</b>	<b>#</b>	<b>Name</b>	<b>Target Coordinates</b>		<b>Targ. Coord. Corrections</b>		<b>Fluxes</b>		<b>Miscellaneous</b>		
	(2)	M101-B	RA: 14 02 32.3659 (210.6348579d) Dec: +54 26 41.11 (54.44475d) Equinox: J2000				V=25		Reference Frame: xdss		
<b>Exposures</b>	<b>#</b>	<b>Label</b>	<b>Target</b>	<b>Config,Mode,Aperture</b>	<b>Spectral Els.</b>	<b>Opt. Params.</b>	<b>Special Reqs.</b>	<b>Groups</b>	<b>Exp. Time/[Actual Dur.]</b>		<b>Orbit</b>
	1	(2) M101-B		WFC3/UVIS, ACCUM, UVIS-CENTER	F469N	CR-SPLIT=NO		Pattern 1, Exps 1-1 (1)	1492 Secs		
									[=>(Pattern 1)]		[1]
									[=>(Pattern 2)]		
								[=>1561 Secs (Pattern 3)]			
								[=>1561 Secs (Pattern 4)]		[2]	

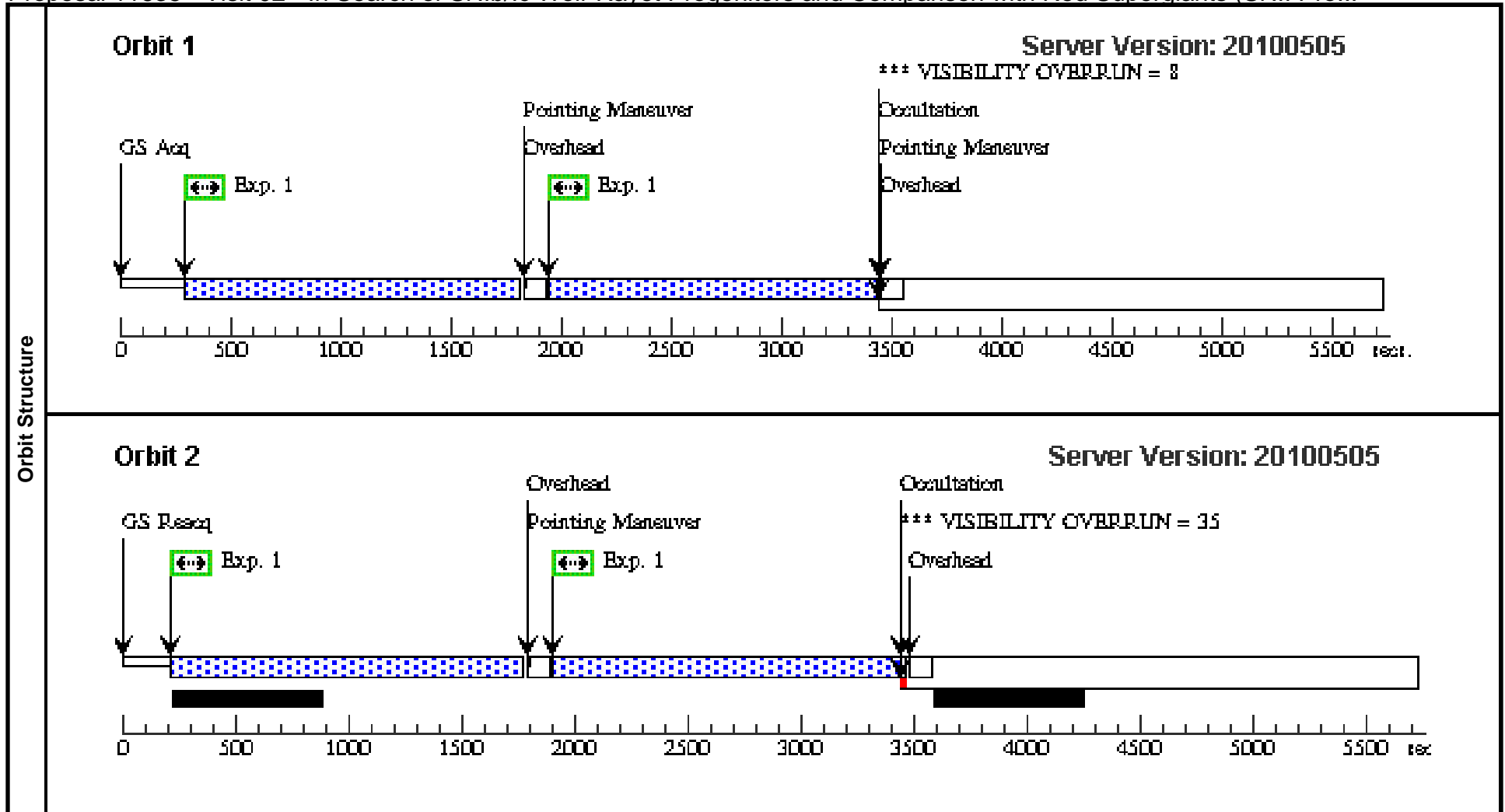

Proposal 11635 - Visit 02 - In Search of SNII/lc Wolf-Rayet Progenitors and Comparison with Red Supergiants (SNII Pro...

Fri Sep 17 01:01:50 GMT 2010

<b>Visit</b>	Proposal 11635, Visit 03, completed Diagnostic Status: Warning Scientific Instruments: WFC3/UVIS Special Requirements: ORIENT 206.0D TO 214.0 D										
	(Visit 03) Warning (Orbit Planner): VISIBILITY OVERRUN (Visit 03) Warning (Orbit Planner): VISIBILITY OVERRUN										
<b>Diagnosics</b>											
<b>Patterns</b>	<b>#</b>	<b>Primary Pattern</b>				<b>Secondary Pattern</b>				<b>Exposures</b>	
	(1)	Pattern Type=WFC3-UVIS-DITHER-BOX Purpose=DITHER Number Of Points=4 Point Spacing=0.173 Line Spacing=0.112				Coordinate Frame=POS-TARG Pattern Orientation=23.884 Angle Between Sides=81.785 Center Pattern=false				(1)	
<b>Fixed Targets</b>	<b>#</b>	<b>Name</b>	<b>Target Coordinates</b>		<b>Targ. Coord. Corrections</b>		<b>Fluxes</b>		<b>Miscellaneous</b>		
	(3)	M101-C	RA: 14 02 52.0093 (210.7167054d) Dec: +54 24 39.61 (54.41100d) Equinox: J2000				V=25		Reference Frame: xdss		
<b>Exposures</b>	<b>#</b>	<b>Label</b>	<b>Target</b>	<b>Config,Mode,Aperture</b>	<b>Spectral Els.</b>	<b>Opt. Params.</b>	<b>Special Reqs.</b>	<b>Groups</b>	<b>Exp. Time/[Actual Dur.]</b>		<b>Orbit</b>
	1	(3) M101-C		WFC3/UVIS, ACCUM, UVIS-CENTER	F469N	CR-SPLIT=NO		Pattern 1, Exps 1-1 (1)	1492 Secs		
									[=>(Pattern 1)]		[1]
									[=>(Pattern 2)]		
									[=>1561 Secs (Pattern 3)]		
									[=>1561 Secs (Pattern 4)]		[2]

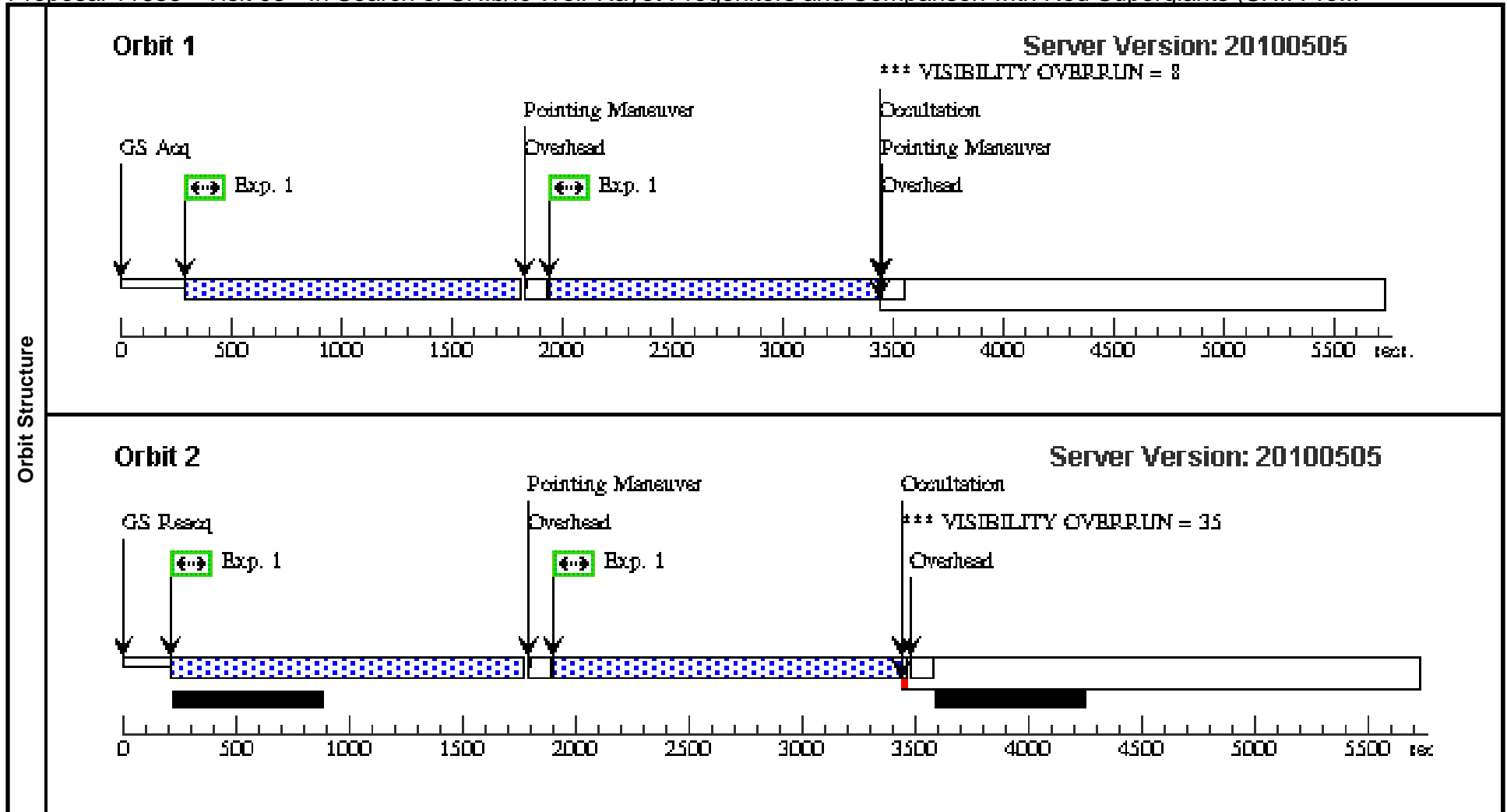

Proposal 11635 - Visit 03 - In Search of SNII/lc Wolf-Rayet Progenitors and Comparison with Red Supergiants (SNII Pro...

Fri Sep 17 01:01:50 GMT 2010

<b>Visit</b>	Proposal 11635, Visit 04, completed <b>Diagnostic Status: Warning</b> Scientific Instruments: WFC3/UVIS Special Requirements: ORIENT 206.0D TO 214.0 D									
	<b>Diagnostics</b>	(Visit 04) Warning (Orbit Planner): VISIBILITY OVERRUN (Visit 04) Warning (Orbit Planner): VISIBILITY OVERRUN								
<b>Patterns</b>		<b>#</b>	<b>Primary Pattern</b>				<b>Secondary Pattern</b>			
	(1)	Pattern Type=WFC3-UVIS-DITHER-BOX Purpose=DITHER Number Of Points=4 Point Spacing=0.173 Line Spacing=0.112				Coordinate Frame=POS-TARG Pattern Orientation=23.884 Angle Between Sides=81.785 Center Pattern=false				(1)
<b>Fixed Targets</b>	<b>#</b>	<b>Name</b>	<b>Target Coordinates</b>		<b>Targ. Coord. Corrections</b>		<b>Fluxes</b>	<b>Miscellaneous</b>		
	(4)	M101-D	RA: 14 02 34.0005 (210.6416688d) Dec: +54 23 58.66 (54.39963d) Equinox: J2000				V=25	Reference Frame: xdss		
<b>Exposures</b>	<b>#</b>	<b>Label</b>	<b>Target</b>	<b>Config,Mode,Aperture</b>	<b>Spectral Els.</b>	<b>Opt. Params.</b>	<b>Special Reqs.</b>	<b>Groups</b>	<b>Exp. Time/[Actual Dur.]</b>	<b>Orbit</b>
	1	(4) M101-D		WFC3/UVIS, ACCUM, UVIS-CENTER	F469N	CR-SPLIT=NO		Pattern 1, Exps 1-1 (1)	1492 Secs	
									[==>(Pattern 1)]	[1]
									[==>(Pattern 2)]	
								[==>1561 Secs (Pattern 3)]		
								[==>1561 Secs (Pattern 4)]		[2]

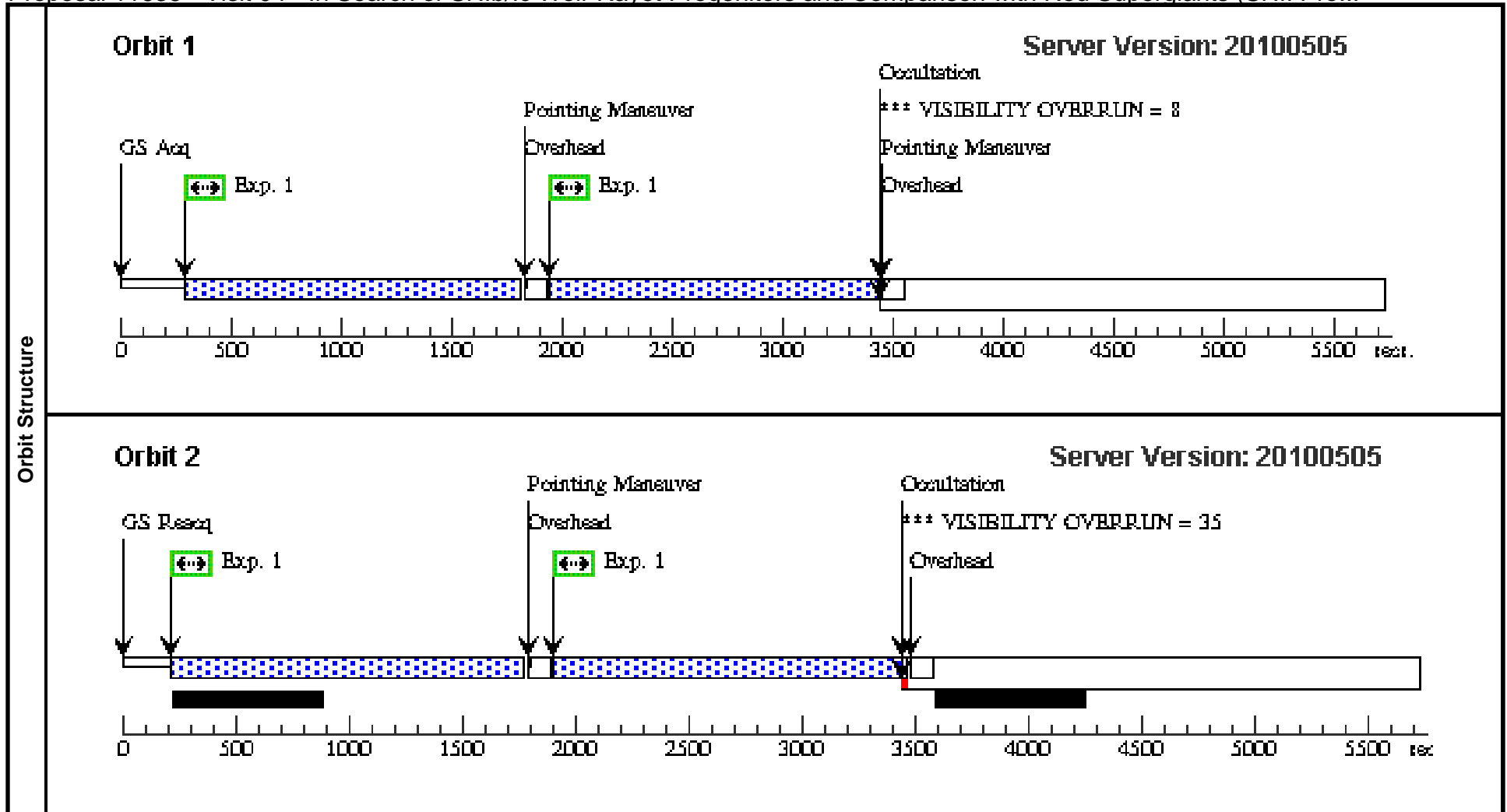

Proposal 11635 - Visit 04 - In Search of SNII/lc Wolf-Rayet Progenitors and Comparison with Red Supergiants (SNII Pro...

Fri Sep 17 01:01:51 GMT 2010

<b>Visit</b>	Proposal 11635, Visit 05, completed <b>Diagnostic Status: Warning</b> Scientific Instruments: WFC3/UVIS Special Requirements: ORIENT 201.0D TO 209.0 D										
	(Visit 05) Warning (Orbit Planner): VISIBILITY OVERRUN (Visit 05) Warning (Orbit Planner): VISIBILITY OVERRUN										
<b>Diagnosics</b>											
<b>Patterns</b>	<b>#</b>	<b>Primary Pattern</b>				<b>Secondary Pattern</b>				<b>Exposures</b>	
	(1)	Pattern Type=WFC3-UVIS-DITHER-BOX Purpose=DITHER Number Of Points=4 Point Spacing=0.173 Line Spacing=0.112				Coordinate Frame=POS-TARG Pattern Orientation=23.884 Angle Between Sides=81.785 Center Pattern=false				(1)	
<b>Fixed Targets</b>	<b>#</b>	<b>Name</b>	<b>Target Coordinates</b>		<b>Targ. Coord. Corrections</b>		<b>Fluxes</b>		<b>Miscellaneous</b>		
	(5)	M101-E	RA: 14 03 24.7407 (210.8530863d) Dec: +54 23 36.86 (54.39357d) Equinox: J2000				V=25		Reference Frame: xdss		
<b>Exposures</b>	<b>#</b>	<b>Label</b>	<b>Target</b>	<b>Config,Mode,Aperture</b>	<b>Spectral Els.</b>	<b>Opt. Params.</b>	<b>Special Reqs.</b>	<b>Groups</b>	<b>Exp. Time/[Actual Dur.]</b>		<b>Orbit</b>
	1	(5) M101-E		WFC3/UVIS, ACCUM, UVIS-CENTER	F469N	CR-SPLIT=NO	GS ACQ SCENARI O BASE1B3	Pattern 1, Exps 1-1 (1)	1492 Secs		
									[=>(Pattern 1)]		[1]
									[=>(Pattern 2)]		
									[=>1561 Secs (Pattern 3)]		
									[=>1561 Secs (Pattern 4)]		[2]

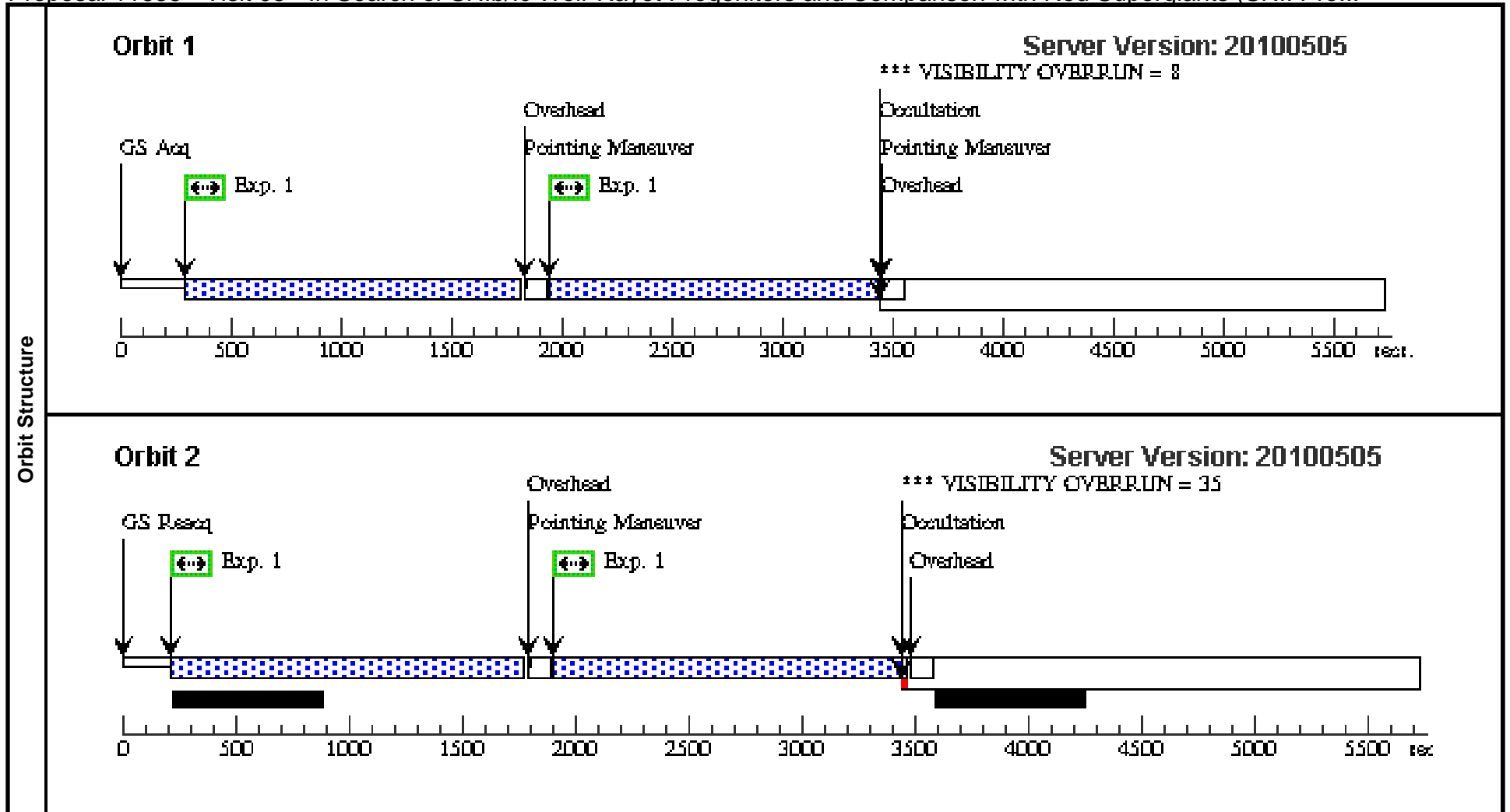

Proposal 11635 - Visit 05 - In Search of SNII/lc Wolf-Rayet Progenitors and Comparison with Red Supergiants (SNII Pro...

Fri Sep 17 01:01:51 GMT 2010

<b>Visit</b>	<b>Proposal 11635, Visit 06, completed</b> <b>Diagnostic Status: Warning</b> Scientific Instruments: WFC3/UVIS Special Requirements: ORIENT 201.0D TO 209.0 D										
	(Visit 06) Warning (Orbit Planner): VISIBILITY OVERRUN (Visit 06) Warning (Orbit Planner): VISIBILITY OVERRUN										
<b>Diagnosics</b>											
<b>Patterns</b>	<b>#</b>	<b>Primary Pattern</b>				<b>Secondary Pattern</b>				<b>Exposures</b>	
	(1)	Pattern Type=WFC3-UVIS-DITHER-BOX Purpose=DITHER Number Of Points=4 Point Spacing=0.173 Line Spacing=0.112				Coordinate Frame=POS-TARG Pattern Orientation=23.884 Angle Between Sides=81.785 Center Pattern=false				(1)	
<b>Fixed Targets</b>	<b>#</b>	<b>Name</b>	<b>Target Coordinates</b>		<b>Targ. Coord. Corrections</b>		<b>Fluxes</b>		<b>Miscellaneous</b>		
	(6)	M101-F	RA: 14 03 7.4622 (210.7810925d) Dec: +54 22 32.96 (54.37582d) Equinox: J2000				V=25		Reference Frame: xdss		
<b>Exposures</b>	<b>#</b>	<b>Label</b>	<b>Target</b>	<b>Config,Mode,Aperture</b>	<b>Spectral Els.</b>	<b>Opt. Params.</b>	<b>Special Reqs.</b>	<b>Groups</b>	<b>Exp. Time/[Actual Dur.]</b>		<b>Orbit</b>
	1	(6) M101-F		WFC3/UVIS, ACCUM, UVIS-CENTER	F469N	CR-SPLIT=NO		Pattern 1, Exps 1-1 (1)	1492 Secs		
									[=>(Pattern 1)]		[1]
									[=>(Pattern 2)]		
								[=>1561 Secs (Pattern 3)]			
								[=>1561 Secs (Pattern 4)]		[2]	

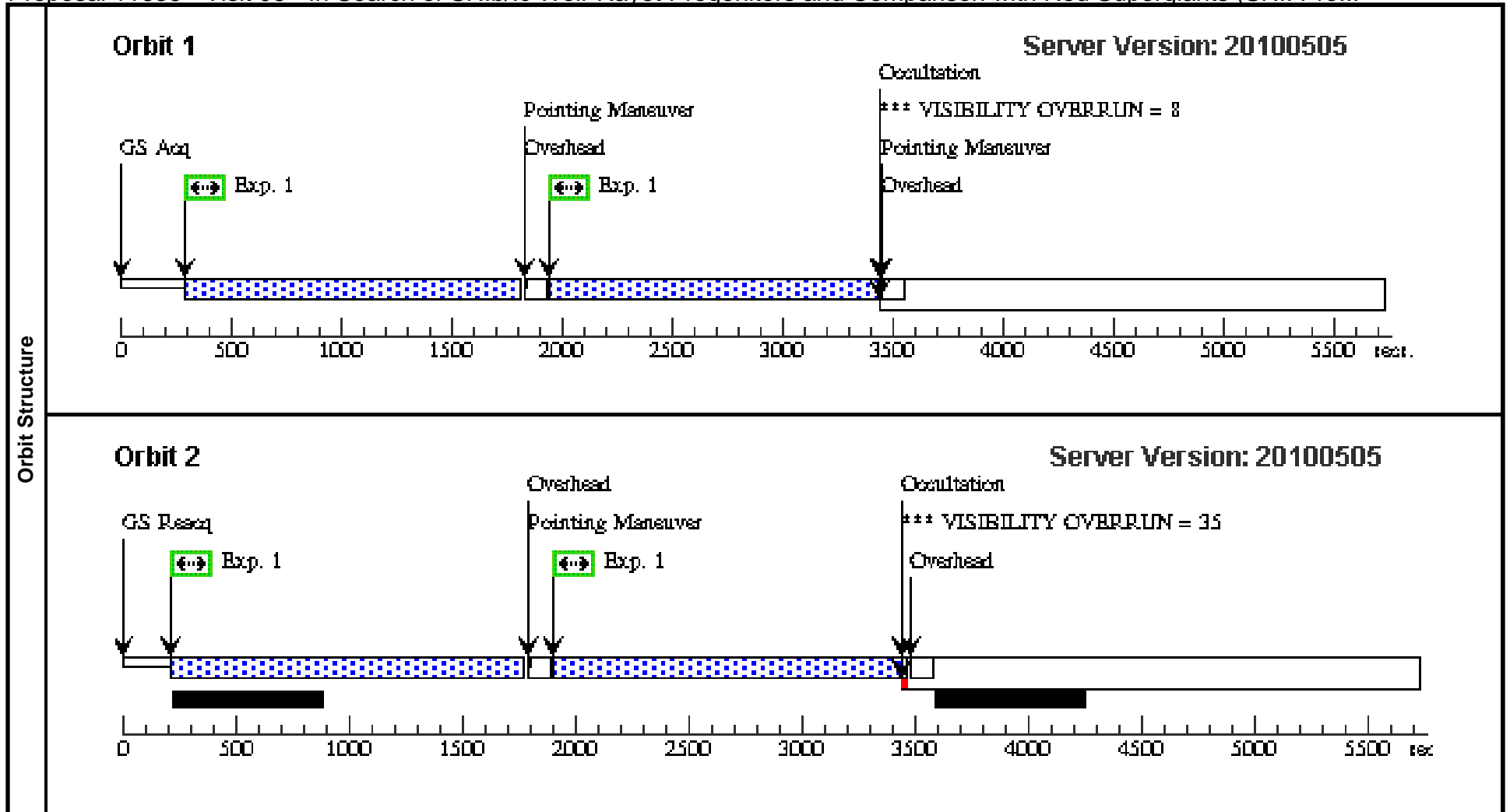

Proposal 11635 - Visit 06 - In Search of SNII/lc Wolf-Rayet Progenitors and Comparison with Red Supergiants (SNII Pro...

Fri Sep 17 01:01:51 GMT 2010

<b>Visit</b>	Proposal 11635, Visit 07, completed Diagnostic Status: Warning Scientific Instruments: WFC3/UVIS Special Requirements: ORIENT 206.0D TO 214.0 D										
	<b>Diagnostics</b>	(Visit 07) Warning (Orbit Planner): VISIBILITY OVERRUN (Visit 07) Warning (Orbit Planner): VISIBILITY OVERRUN									
<b>Patterns</b>		#	Primary Pattern				Secondary Pattern				Exposures
	(1)	Pattern Type=WFC3-UVIS-DITHER-BOX Purpose=DITHER Number Of Points=4 Point Spacing=0.173 Line Spacing=0.112				Coordinate Frame=POS-TARG Pattern Orientation=23.884 Angle Between Sides=81.785 Center Pattern=false				(1)	
<b>Fixed Targets</b>	#	Name	Target Coordinates		Targ. Coord. Corrections		Fluxes		Miscellaneous		
	(7)	M101-G	RA: 14 02 50.0625 (210.7085938d) Dec: +54 21 46.28 (54.36286d) Equinox: J2000				V=25		Reference Frame: xdss		
<b>Exposures</b>	#	Label	Target	Config,Mode,Aperture	Spectral Els.	Opt. Params.	Special Reqs.	Groups	Exp. Time/[Actual Dur.]		Orbit
	1	(7) M101-G		WFC3/UVIS, ACCUM, UVIS-CENTER	F469N	CR-SPLIT=NO	GS ACQ SCENARI O BASE1B3	Pattern 1, Exps 1-1 (1)	1492 Secs		
									[=>(Pattern 1)]		[1]
									[=>(Pattern 2)]		
									[=>1561 Secs (Pattern 3)]		
									[=>1561 Secs (Pattern 4)]		[2]

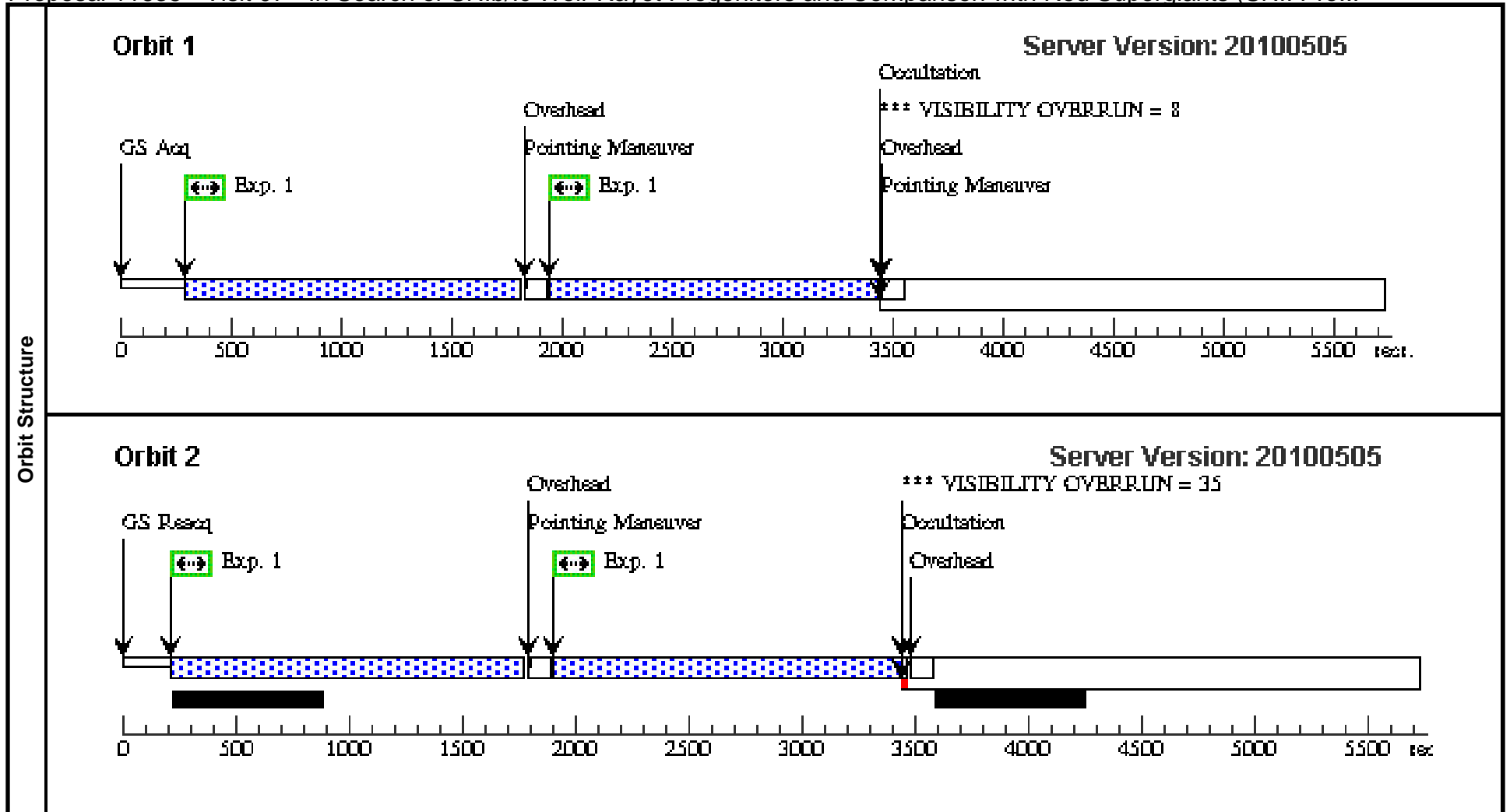

Proposal 11635 - Visit 07 - In Search of SNII/lc Wolf-Rayet Progenitors and Comparison with Red Supergiants (SNII Pro...

Fri Sep 17 01:01:52 GMT 2010

<b>Visit</b>	Proposal 11635, Visit 08, completed <b>Diagnostic Status: Warning</b> Scientific Instruments: WFC3/UVIS Special Requirements: ORIENT 206.0D TO 214.0 D										
	<b>Diagnostics</b>	(Visit 08) Warning (Orbit Planner): VISIBILITY OVERRUN (Visit 08) Warning (Orbit Planner): VISIBILITY OVERRUN									
<b>Patterns</b>		<b>#</b>	<b>Primary Pattern</b>				<b>Secondary Pattern</b>				<b>Exposures</b>
	(1)	Pattern Type=WFC3-UVIS-DITHER-BOX Purpose=DITHER Number Of Points=4 Point Spacing=0.173 Line Spacing=0.112				Coordinate Frame=POS-TARG Pattern Orientation=23.884 Angle Between Sides=81.785 Center Pattern=false				(1)	
<b>Fixed Targets</b>	<b>#</b>	<b>Name</b>	<b>Target Coordinates</b>		<b>Targ. Coord. Corrections</b>		<b>Fluxes</b>	<b>Miscellaneous</b>			
	(8)	M101-H	RA: 14 02 32.0024 (210.6333433d) Dec: +54 21 6.24 (54.35173d) Equinox: J2000				V=25	Reference Frame: xdss			
<b>Exposures</b>	<b>#</b>	<b>Label</b>	<b>Target</b>	<b>Config,Mode,Aperture</b>	<b>Spectral Els.</b>	<b>Opt. Params.</b>	<b>Special Reqs.</b>	<b>Groups</b>	<b>Exp. Time/[Actual Dur.]</b>		<b>Orbit</b>
	1	(8) M101-H		WFC3/UVIS, ACCUM, UVIS-CENTER	F469N	CR-SPLIT=NO	GS ACQ SCENARI O BASE1B3	Pattern 1, Exps 1-1 (1)	1492 Secs		
									[=>(Pattern 1)]		[1]
									[=>(Pattern 2)]		
									[=>1561 Secs (Pattern 3)]		
									[=>1561 Secs (Pattern 4)]		[2]

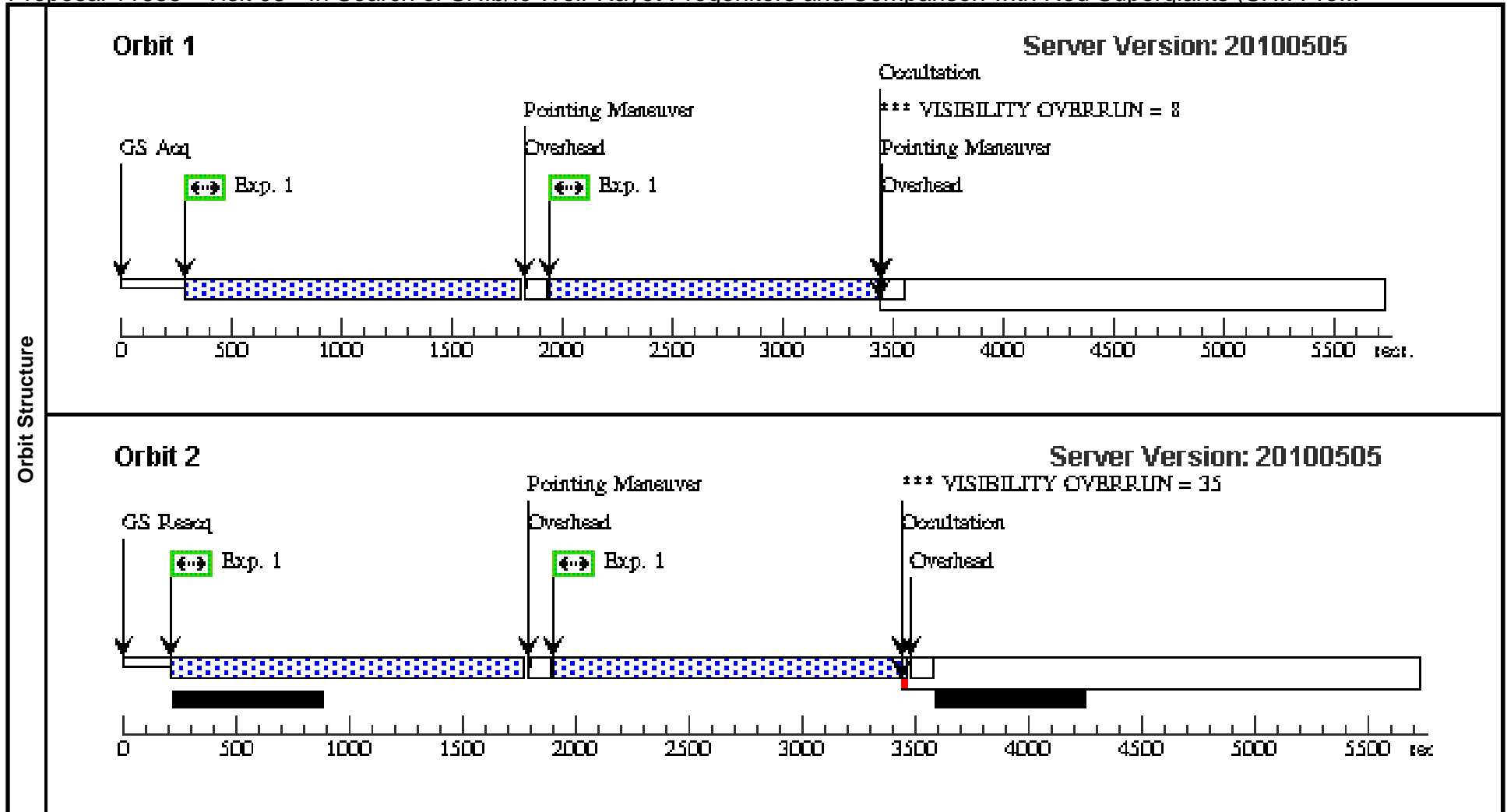

Proposal 11635 - Visit 08 - In Search of SNII/lc Wolf-Rayet Progenitors and Comparison with Red Supergiants (SNII Pro...

Fri Sep 17 01:01:52 GMT 2010

<b>Visit</b>	Proposal 11635, Visit 09, completed Diagnostic Status: Warning Scientific Instruments: WFC3/UVIS Special Requirements: ORIENT 201.0D TO 209.0 D										
	(Visit 09) Warning (Orbit Planner): VISIBILITY OVERRUN (Visit 09) Warning (Orbit Planner): VISIBILITY OVERRUN										
<b>Diagnosics</b>											
<b>Patterns</b>	#	<b>Primary Pattern</b>				<b>Secondary Pattern</b>				<b>Exposures</b>	
	(1)	Pattern Type=WFC3-UVIS-DITHER-BOX Purpose=DITHER Number Of Points=4 Point Spacing=0.173 Line Spacing=0.112				Coordinate Frame=POS-TARG Pattern Orientation=23.884 Angle Between Sides=81.785 Center Pattern=false				(1)	
<b>Fixed Targets</b>	#	<b>Name</b>	<b>Target Coordinates</b>		<b>Targ. Coord. Corrections</b>		<b>Fluxes</b>		<b>Miscellaneous</b>		
	(9)	M101-I	RA: 14 03 45.0945 (210.9378938d) Dec: +54 22 16.06 (54.37113d) Equinox: J2000				V=25		Reference Frame: xdss		
<b>Exposures</b>	#	<b>Label</b>	<b>Target</b>	<b>Config,Mode,Aperture</b>	<b>Spectral Els.</b>	<b>Opt. Params.</b>	<b>Special Reqs.</b>	<b>Groups</b>	<b>Exp. Time/[Actual Dur.]</b>		<b>Orbit</b>
	1	(9) M101-I		WFC3/UVIS, ACCUM, UVIS-CENTER	F469N	CR-SPLIT=NO		Pattern 1, Exps 1-1 (1)	1492 Secs		
									[=>(Pattern 1)]		[1]
									[=>(Pattern 2)]		
									[=>1561 Secs (Pattern 3)]		
									[=>1561 Secs (Pattern 4)]		[2]

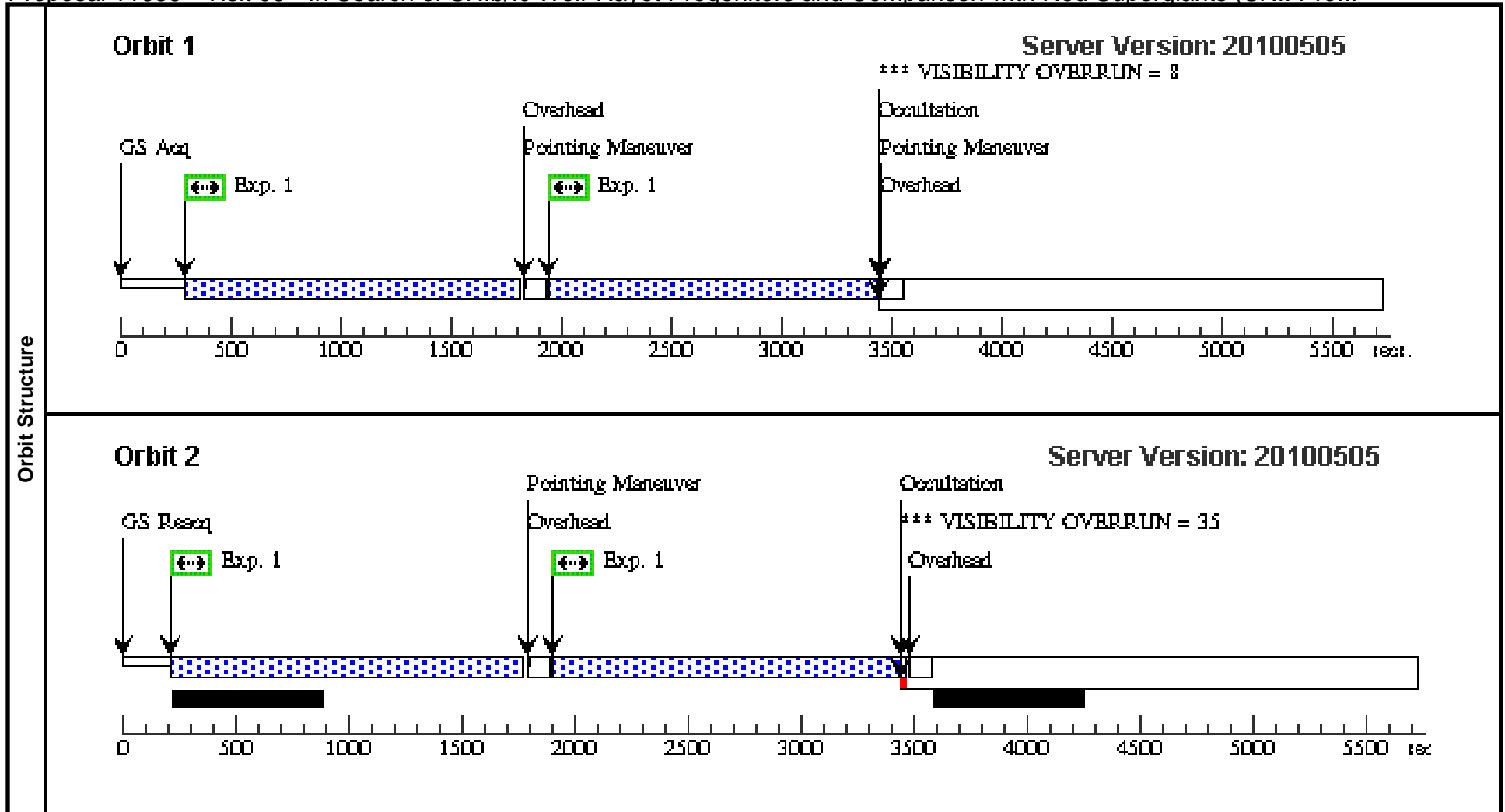

Proposal 11635 - Visit 09 - In Search of SNIb/lc Wolf-Rayet Progenitors and Comparison with Red Supergiants (SNII Pro...

Fri Sep 17 01:01:53 GMT 2010

<b>Visit</b>	Proposal 11635, Visit 10, completed <b>Diagnostic Status: Warning</b> Scientific Instruments: WFC3/UVIS Special Requirements: ORIENT 201.0D TO 209.0 D										
	<b>Diagnostics</b>	(Visit 10) Warning (Orbit Planner): VISIBILITY OVERRUN (Visit 10) Warning (Orbit Planner): VISIBILITY OVERRUN									
<b>Patterns</b>		<b>#</b>	<b>Primary Pattern</b>				<b>Secondary Pattern</b>				<b>Exposures</b>
	(1)	Pattern Type=WFC3-UVIS-DITHER-BOX Purpose=DITHER Number Of Points=4 Point Spacing=0.173 Line Spacing=0.112				Coordinate Frame=POS-TARG Pattern Orientation=23.884 Angle Between Sides=81.785 Center Pattern=false				(1)	
<b>Fixed Targets</b>	<b>#</b>	<b>Name</b>	<b>Target Coordinates</b>		<b>Targ. Coord. Corrections</b>		<b>Fluxes</b>	<b>Miscellaneous</b>			
	(10)	M101-J	RA: 14 03 28.4184 (210.8684100d) Dec: +54 20 55.28 (54.34869d) Equinox: J2000				V=25	Reference Frame: xdss			
<b>Exposures</b>	<b>#</b>	<b>Label</b>	<b>Target</b>	<b>Config,Mode,Aperture</b>	<b>Spectral Els.</b>	<b>Opt. Params.</b>	<b>Special Reqs.</b>	<b>Groups</b>	<b>Exp. Time/[Actual Dur.]</b>		<b>Orbit</b>
	1	(10) M101-J		WFC3/UVIS, ACCUM, UVIS-CENTER	F469N	CR-SPLIT=NO		Pattern 1, Exps 1-1 (1)	1492 Secs		
									[==>(Pattern 1)]		[1]
									[==>(Pattern 2)]		
								[==>1561 Secs (Pattern 3)]			
								[==>1561 Secs (Pattern 4)]			[2]

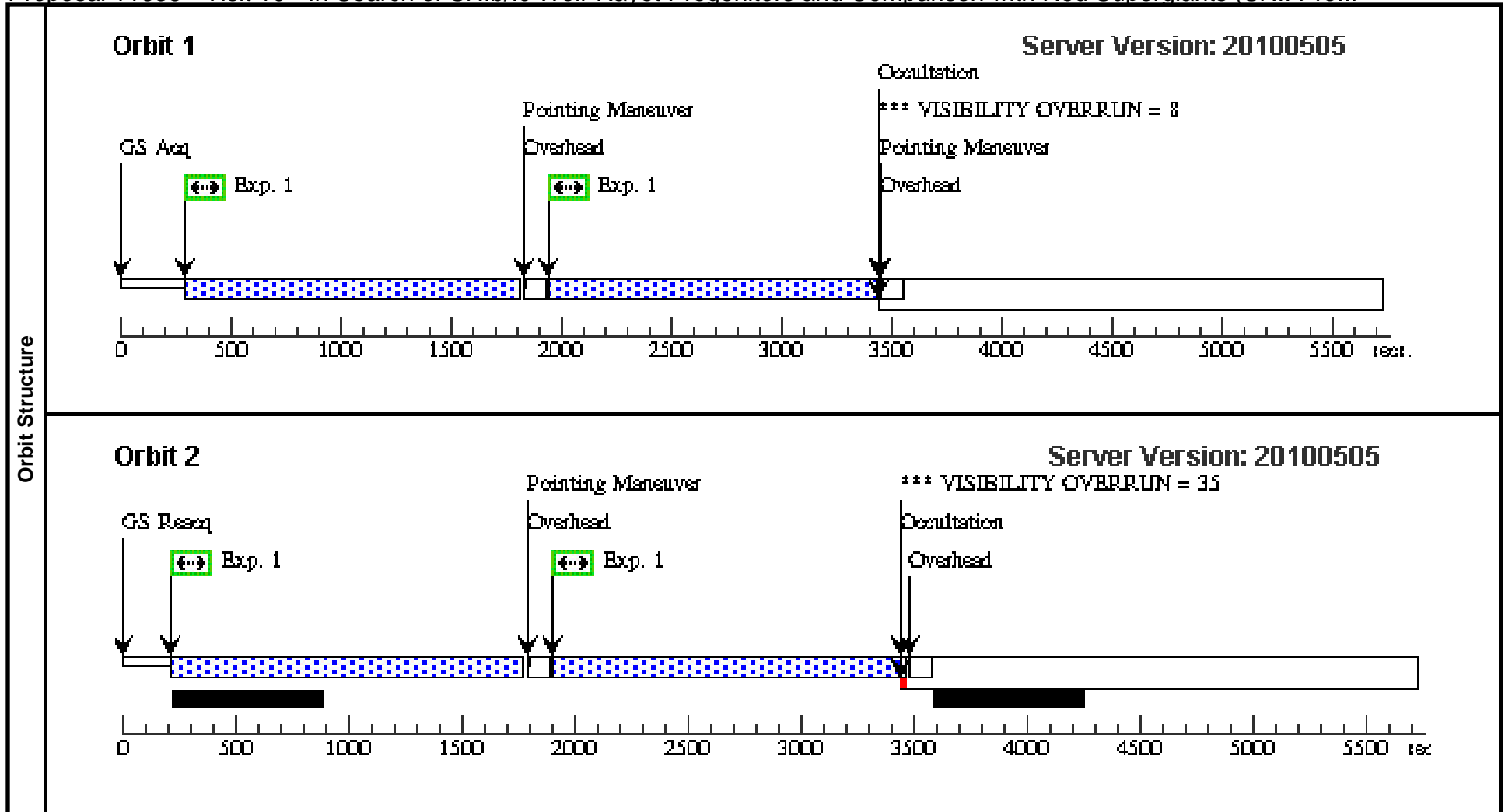

Proposal 11635 - Visit 10 - In Search of SNII/lc Wolf-Rayet Progenitors and Comparison with Red Supergiants (SNII Pro...

Fri Sep 17 01:01:53 GMT 2010

<b>Visit</b>	Proposal 11635, Visit 11, completed <b>Diagnostic Status: Warning</b> Scientific Instruments: WFC3/UVIS Special Requirements: ORIENT 201.0D TO 209.0 D										
	<b>Diagnostics</b>	(Visit 11) Warning (Orbit Planner): VISIBILITY OVERRUN (Visit 11) Warning (Orbit Planner): VISIBILITY OVERRUN									
<b>Patterns</b>		<b>#</b>	<b>Primary Pattern</b>				<b>Secondary Pattern</b>				<b>Exposures</b>
	(1)	Pattern Type=WFC3-UVIS-DITHER-BOX Purpose=DITHER Number Of Points=4 Point Spacing=0.173 Line Spacing=0.112				Coordinate Frame=POS-TARG Pattern Orientation=23.884 Angle Between Sides=81.785 Center Pattern=false				(1)	
<b>Fixed Targets</b>	<b>#</b>	<b>Name</b>	<b>Target Coordinates</b>		<b>Targ. Coord. Corrections</b>		<b>Fluxes</b>	<b>Miscellaneous</b>			
	(11)	M101-K	RA: 14 03 11.0992 (210.7962467d) Dec: +54 19 55.07 (54.33196d) Equinox: J2000				V=25	Reference Frame: xdss			
<b>Exposures</b>	<b>#</b>	<b>Label</b>	<b>Target</b>	<b>Config,Mode,Aperture</b>	<b>Spectral Els.</b>	<b>Opt. Params.</b>	<b>Special Reqs.</b>	<b>Groups</b>	<b>Exp. Time/[Actual Dur.]</b>		<b>Orbit</b>
	1	(11) M101-K		WFC3/UVIS, ACCUM, UVIS-CENTER	F469N	CR-SPLIT=NO	GS ACQ SCENARI O BASE1B3	Pattern 1, Exps 1-1 (1)	1492 Secs		
									[=>(Pattern 1)]		[1]
									[=>(Pattern 2)]		
									[=>1561 Secs (Pattern 3)]		
									[=>1561 Secs (Pattern 4)]		[2]

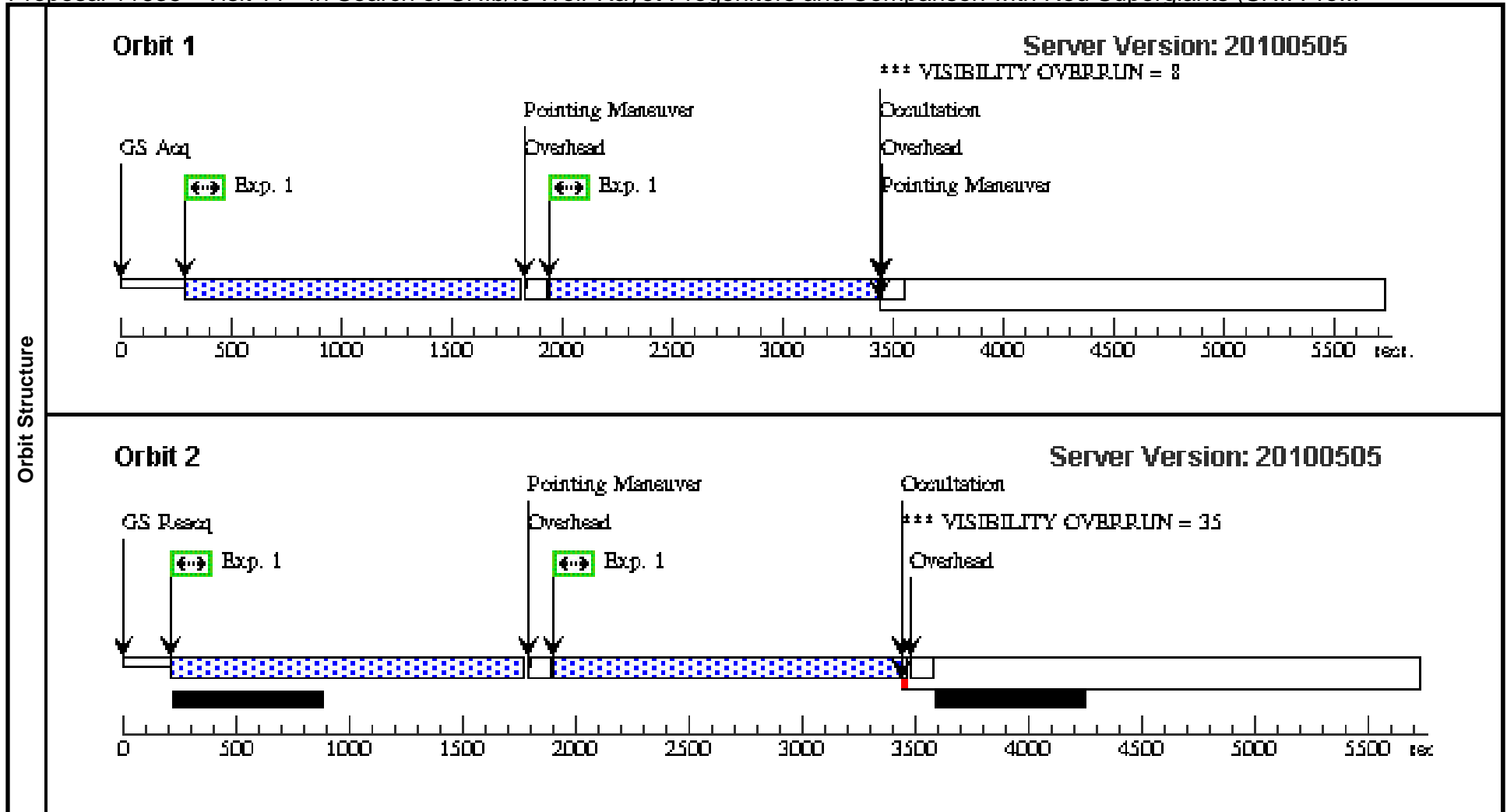

Proposal 11635 - Visit 11 - In Search of SNII/lc Wolf-Rayet Progenitors and Comparison with Red Supergiants (SNII Pro...

Fri Sep 17 01:01:53 GMT 2010

<b>Visit</b>	Proposal 11635, Visit 12, completed <b>Diagnostic Status: Warning</b> Scientific Instruments: WFC3/UVIS Special Requirements: ORIENT 116.0D TO 124.0 D									
	<b>Diagnostics</b>	(Visit 12) Warning (Orbit Planner): VISIBILITY OVERRUN (Visit 12) Warning (Orbit Planner): VISIBILITY OVERRUN								
<b>Patterns</b>		<b>#</b>	<b>Primary Pattern</b>			<b>Secondary Pattern</b>			<b>Exposures</b>	
	(1)	Pattern Type=WFC3-UVIS-DITHER-BOX Purpose=DITHER Number Of Points=4 Point Spacing=0.173 Line Spacing=0.112			Coordinate Frame=POS-TARG Pattern Orientation=23.884 Angle Between Sides=81.785 Center Pattern=false			(1)		
<b>Fixed Targets</b>	<b>#</b>	<b>Name</b>	<b>Target Coordinates</b>	<b>Targ. Coord. Corrections</b>	<b>Fluxes</b>	<b>Miscellaneous</b>				
	(12)	M101-L	RA: 14 02 53.6211 (210.7234212d) Dec: +54 19 10.16 (54.31949d) Equinox: J2000		V=25	Reference Frame: xdss				
<b>Exposures</b>	<b>#</b>	<b>Label</b>	<b>Target</b>	<b>Config,Mode,Aperture</b>	<b>Spectral Els.</b>	<b>Opt. Params.</b>	<b>Special Reqs.</b>	<b>Groups</b>	<b>Exp. Time/[Actual Dur.]</b>	<b>Orbit</b>
	1	(12) M101-L		WFC3/UVIS, ACCUM, UVIS-CENTER	F469N	CR-SPLIT=NO		Pattern 1, Exps 1-1 (1)	1492 Secs	
									[==>(Pattern 1)]	[1]
									[==>(Pattern 2)]	
								[==>1561 Secs (Pattern 3)]		
								[==>1561 Secs (Pattern 4)]		[2]

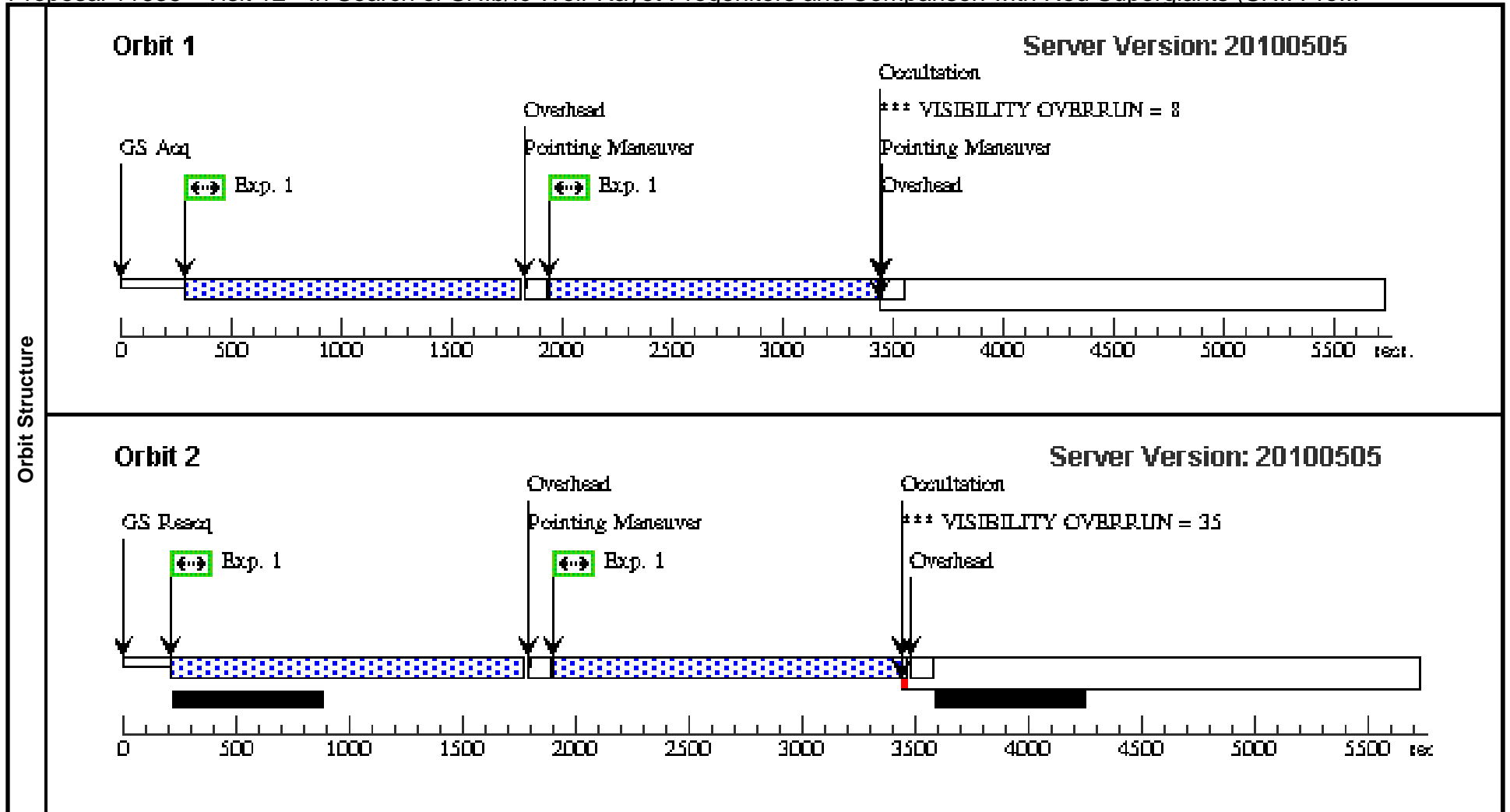

Proposal 11635 - Visit 12 - In Search of SNII/lc Wolf-Rayet Progenitors and Comparison with Red Supergiants (SNII Pro...

Fri Sep 17 01:01:54 GMT 2010

Visit	Proposal 11635, Visit 13, scheduling Diagnostic Status: No Diagnostics Scientific Instruments: WFC3/UVIS Special Requirements: ORIENT 32,43D TO 35 D										
	Patterns	#	Primary Pattern				Secondary Pattern			Exposures	
		(1)	Pattern Type=WFC3-UVIS-DITHER-BOX Purpose=DITHER Number Of Points=4 Point Spacing=0.173 Line Spacing=0.112	Coordinate Frame=POS-TARG Pattern Orientation=23.884 Angle Between Sides=81.785 Center Pattern=false							(1)
Fixed Targets	#	Name	Target Coordinates		Targ. Coord. Corrections		Fluxes		Miscellaneous		
	(13)	M101-M	RA: 14 02 35.3911 (210.6474629d) Dec: +54 18 32.33 (54.30898d) Equinox: J2000				V=25			Reference Frame: xdss	
Exposures	#	Label	Target	Config,Mode,Aperture	Spectral Els.	Opt. Params.	Special Reqs.	Groups	Exp. Time/[Actual Dur.]		Orbit
	1		(13) M101-M	WFC3/UVIS, ACCUM, UVIS-CENTER	F469N	CR-SPLIT=NO	GS ACQ SCENARIO SINGLE	Pattern 1, Exps 1-1 (1)	1492 Secs		
									[==>(Pattern 1)]		[1]
									[==>(Pattern 2)]		
									[==>1561 Secs (Pattern 3)]		
									[==>1561 Secs (Pattern 4)]		[2]

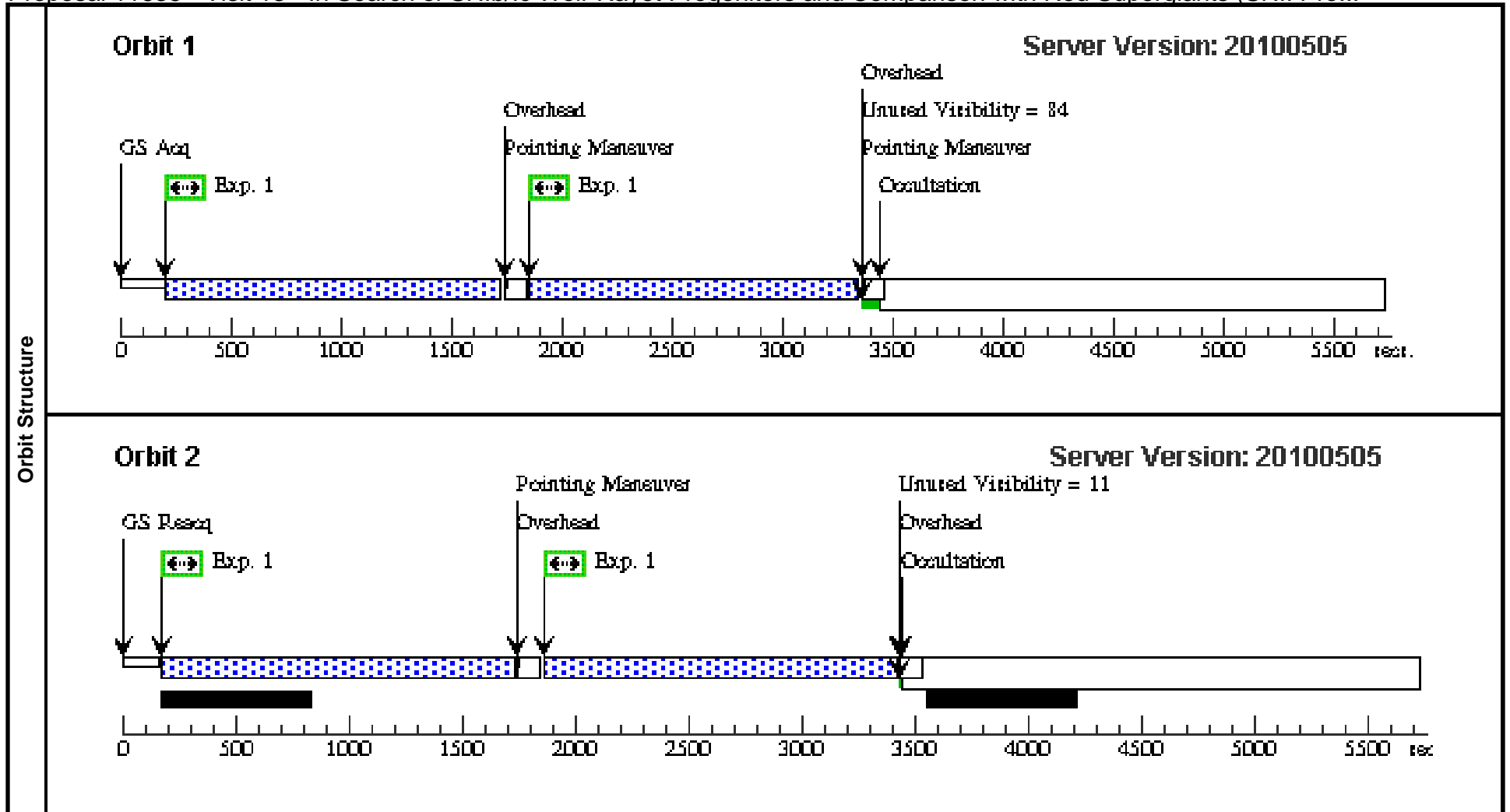

Proposal 11635 - Visit 13 - In Search of SNII/lc Wolf-Rayet Progenitors and Comparison with Red Supergiants (SNII Pro...

Fri Sep 17 01:01:54 GMT 2010

<b>Visit</b>	Proposal 11635, Visit 14, completed Diagnostic Status: Warning Scientific Instruments: WFC3/UVIS Special Requirements: ORIENT 226.0D TO 234.0 D										
	<b>Diagnostics</b>	(Visit 14) Warning (Orbit Planner): VISIBILITY OVERRUN (Visit 14) Warning (Orbit Planner): VISIBILITY OVERRUN									
<b>Patterns</b>		<b>#</b>	<b>Primary Pattern</b>				<b>Secondary Pattern</b>				<b>Exposures</b>
	(1)	Pattern Type=WFC3-UVIS-DITHER-BOX Purpose=DITHER Number Of Points=4 Point Spacing=0.173 Line Spacing=0.112				Coordinate Frame=POS-TARG Pattern Orientation=23.884 Angle Between Sides=81.785 Center Pattern=false				(1)	
<b>Fixed Targets</b>	<b>#</b>	<b>Name</b>	<b>Target Coordinates</b>		<b>Targ. Coord. Corrections</b>		<b>Fluxes</b>	<b>Miscellaneous</b>			
	(14)	M101-N	RA: 14 02 26.5159 (210.6104829d) Dec: +54 18 44.19 (54.31228d) Equinox: J2000				V=25	Reference Frame: xdss			
<b>Exposures</b>	<b>#</b>	<b>Label</b>	<b>Target</b>	<b>Config,Mode,Aperture</b>	<b>Spectral Els.</b>	<b>Opt. Params.</b>	<b>Special Reqs.</b>	<b>Groups</b>	<b>Exp. Time/[Actual Dur.]</b>		<b>Orbit</b>
	1	(14) M101-N		WFC3/UVIS, ACCUM, UVIS-CENTER	F469N	CR-SPLIT=NO	GS ACQ SCENARI O BASE1B3	Pattern 1, Exps 1-1 (1)	1492 Secs		
									[=>(Pattern 1)]		[1]
									[=>(Pattern 2)]		
									[=>1561 Secs (Pattern 3)]		
									[=>1561 Secs (Pattern 4)]		[2]

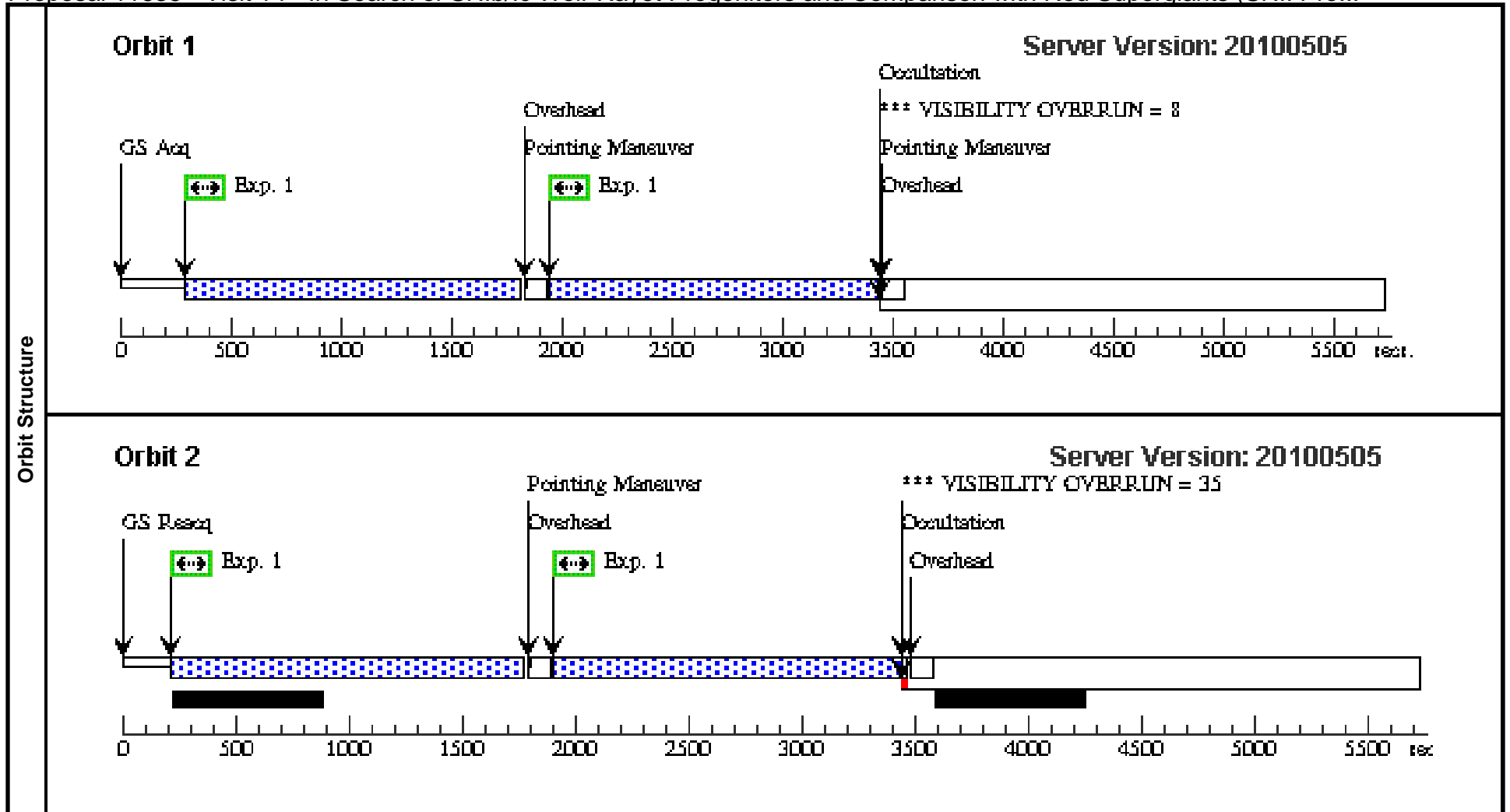

Proposal 11635 - Visit 14 - In Search of SNII/lc Wolf-Rayet Progenitors and Comparison with Red Supergiants (SNII Pro...

Fri Sep 17 01:01:55 GMT 2010

<b>Visit</b>	Proposal 11635, Visit 15, completed <b>Diagnostic Status: Warning</b> Scientific Instruments: WFC3/UVIS Special Requirements: ORIENT 201.0D TO 209.0 D										
	<b>Diagnostics</b>	(Visit 15) Warning (Orbit Planner): VISIBILITY OVERRUN (Visit 15) Warning (Orbit Planner): VISIBILITY OVERRUN									
<b>Patterns</b>		<b>#</b>	<b>Primary Pattern</b>				<b>Secondary Pattern</b>				<b>Exposures</b>
	(1)	Pattern Type=WFC3-UVIS-DITHER-BOX Purpose=DITHER Number Of Points=4 Point Spacing=0.173 Line Spacing=0.112				Coordinate Frame=POS-TARG Pattern Orientation=23.884 Angle Between Sides=81.785 Center Pattern=false				(1)	
<b>Fixed Targets</b>	<b>#</b>	<b>Name</b>	<b>Target Coordinates</b>		<b>Targ. Coord. Corrections</b>		<b>Fluxes</b>	<b>Miscellaneous</b>			
	(15)	M101-O	RA: 14 03 46.6424 (210.9443433d) Dec: +54 19 26.43 (54.32401d) Equinox: J2000				V=25	Reference Frame: xdss			
<b>Exposures</b>	<b>#</b>	<b>Label</b>	<b>Target</b>	<b>Config,Mode,Aperture</b>	<b>Spectral Els.</b>	<b>Opt. Params.</b>	<b>Special Reqs.</b>	<b>Groups</b>	<b>Exp. Time/[Actual Dur.]</b>		<b>Orbit</b>
	1	(15) M101-O		WFC3/UVIS, ACCUM, UVIS-CENTER	F469N	CR-SPLIT=NO		Pattern 1, Exps 1-1 (1)	1492 Secs		
									[==>(Pattern 1)]		[1]
									[==>(Pattern 2)]		
								[==>1561 Secs (Pattern 3)]			
								[==>1561 Secs (Pattern 4)]			

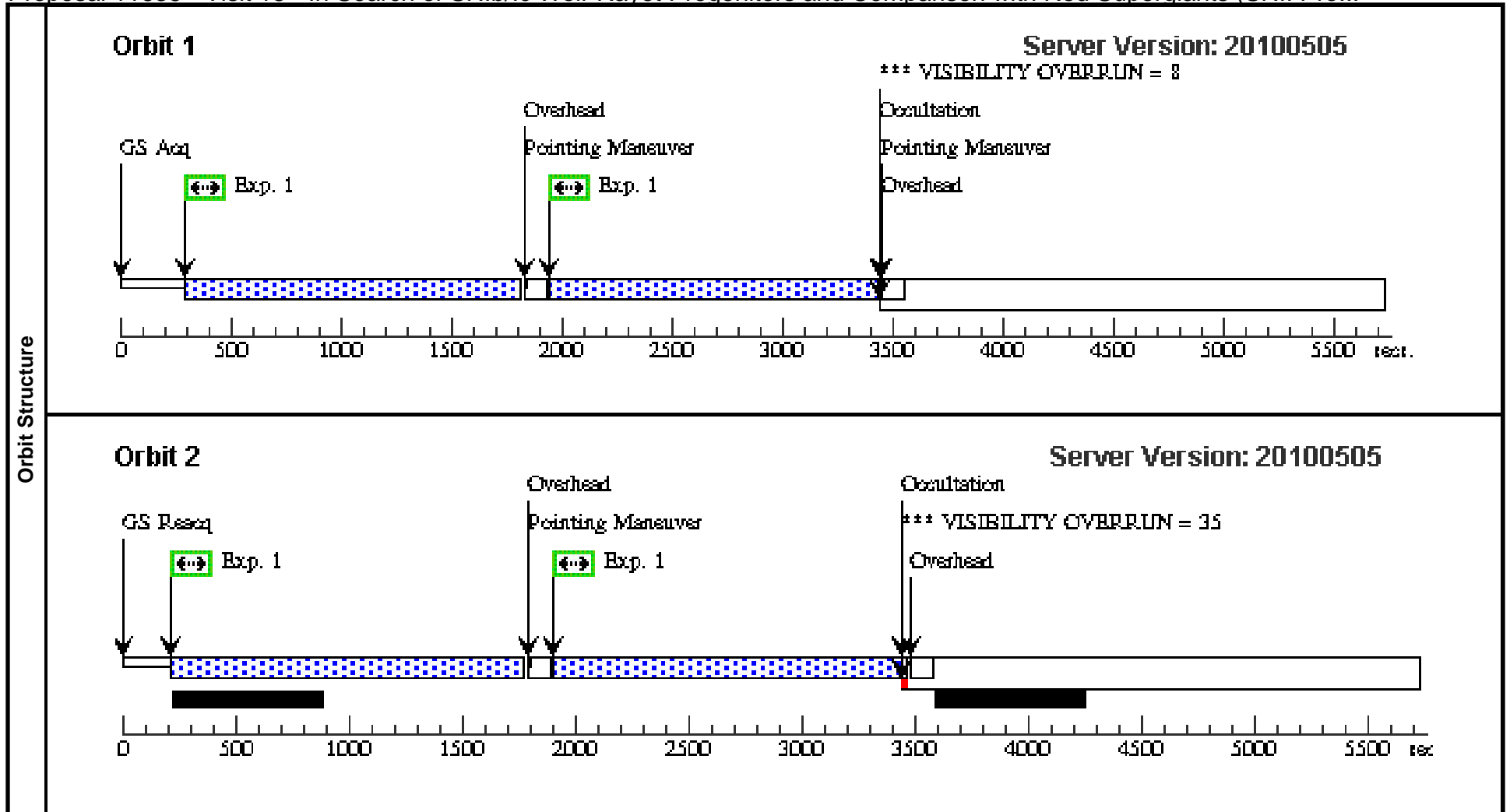

Proposal 11635 - Visit 15 - In Search of SNII/lc Wolf-Rayet Progenitors and Comparison with Red Supergiants (SNII Pro...

Fri Sep 17 01:01:55 GMT 2010

<b>Visit</b>	Proposal 11635, Visit 16, completed Diagnostic Status: Warning Scientific Instruments: WFC3/UVIS Special Requirements: ORIENT 201.0D TO 209.0 D									
	(Visit 16) Warning (Orbit Planner): VISIBILITY OVERRUN (Visit 16) Warning (Orbit Planner): VISIBILITY OVERRUN									
<b>Diagnosics</b>										
<b>Patterns</b>	#	Primary Pattern			Secondary Pattern			Exposures		
	(1)	Pattern Type=WFC3-UVIS-DITHER-BOX Purpose=DITHER Number Of Points=4 Point Spacing=0.173 Line Spacing=0.112			Coordinate Frame=POS-TARG Pattern Orientation=23.884 Angle Between Sides=81.785 Center Pattern=false			(1)		
<b>Fixed Targets</b>	#	Name	Target Coordinates	Targ. Coord. Corrections	Fluxes	Miscellaneous				
	(16)	M101-P	RA: 14 03 29.5145 (210.8729771d) Dec: +54 18 4.39 (54.30122d) Equinox: J2000		V=25	Reference Frame: xdss				
<b>Exposures</b>	#	Label	Target	Config,Mode,Aperture	Spectral Els.	Opt. Params.	Special Reqs.	Groups	Exp. Time/[Actual Dur.]	Orbit
	1	(16) M101-P		WFC3/UVIS, ACCUM, UVIS-CENTER	F469N	CR-SPLIT=NO	GS ACQ SCENARI O BASE1B3	Pattern 1, Exps 1-1 (1)	1492 Secs	
									[==>(Pattern 1)]	[1]
									[==>(Pattern 2)]	
								[==>1561 Secs (Pattern 3)]		
								[==>1561 Secs (Pattern 4)]		

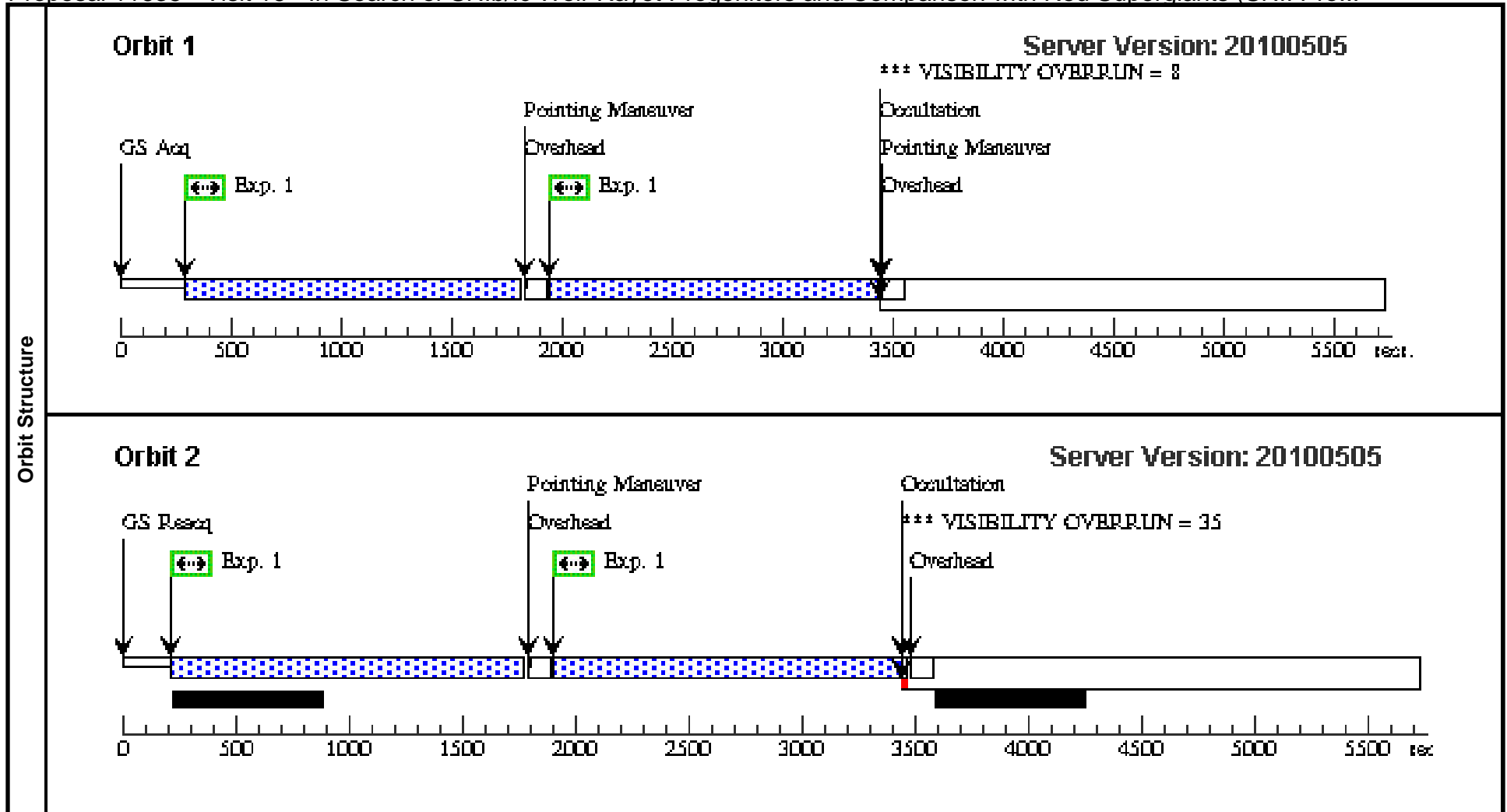

Proposal 11635 - Visit 16 - In Search of SNII/lc Wolf-Rayet Progenitors and Comparison with Red Supergiants (SNII Pro...

Fri Sep 17 01:01:55 GMT 2010

<b>Visit</b>	<b>Proposal 11635, Visit 17, completed</b> <b>Diagnostic Status: Warning</b> Scientific Instruments: WFC3/UVIS Special Requirements: ORIENT 201.0D TO 209.0 D										
	(Visit 17) Warning (Orbit Planner): VISIBILITY OVERRUN (Visit 17) Warning (Orbit Planner): VISIBILITY OVERRUN										
<b>Diagnosics</b>											
<b>Patterns</b>	<b>#</b>	<b>Primary Pattern</b>				<b>Secondary Pattern</b>				<b>Exposures</b>	
	(1)	Pattern Type=WFC3-UVIS-DITHER-BOX Purpose=DITHER Number Of Points=4 Point Spacing=0.173 Line Spacing=0.112				Coordinate Frame=POS-TARG Pattern Orientation=23.884 Angle Between Sides=81.785 Center Pattern=false				(1)	
<b>Fixed Targets</b>	<b>#</b>	<b>Name</b>	<b>Target Coordinates</b>		<b>Targ. Coord. Corrections</b>		<b>Fluxes</b>		<b>Miscellaneous</b>		
	(17)	M101-Q	RA: 14 03 11.9363 (210.7997346d) Dec: +54 17 8.50 (54.28569d) Equinox: J2000				V=25		Reference Frame: xdss		
<b>Exposures</b>	<b>#</b>	<b>Label</b>	<b>Target</b>	<b>Config,Mode,Aperture</b>	<b>Spectral Els.</b>	<b>Opt. Params.</b>	<b>Special Reqs.</b>	<b>Groups</b>	<b>Exp. Time/[Actual Dur.]</b>		<b>Orbit</b>
	1	(17) M101-Q		WFC3/UVIS, ACCUM, UVIS-CENTER	F469N	CR-SPLIT=NO	GS ACQ SCENARI O BASE1B3	Pattern 1, Exps 1-1 (1)	1492 Secs		
									[=>(Pattern 1)]		[1]
									[=>(Pattern 2)]		
								[=>1561 Secs (Pattern 3)]			
								[=>1561 Secs (Pattern 4)]		[2]	

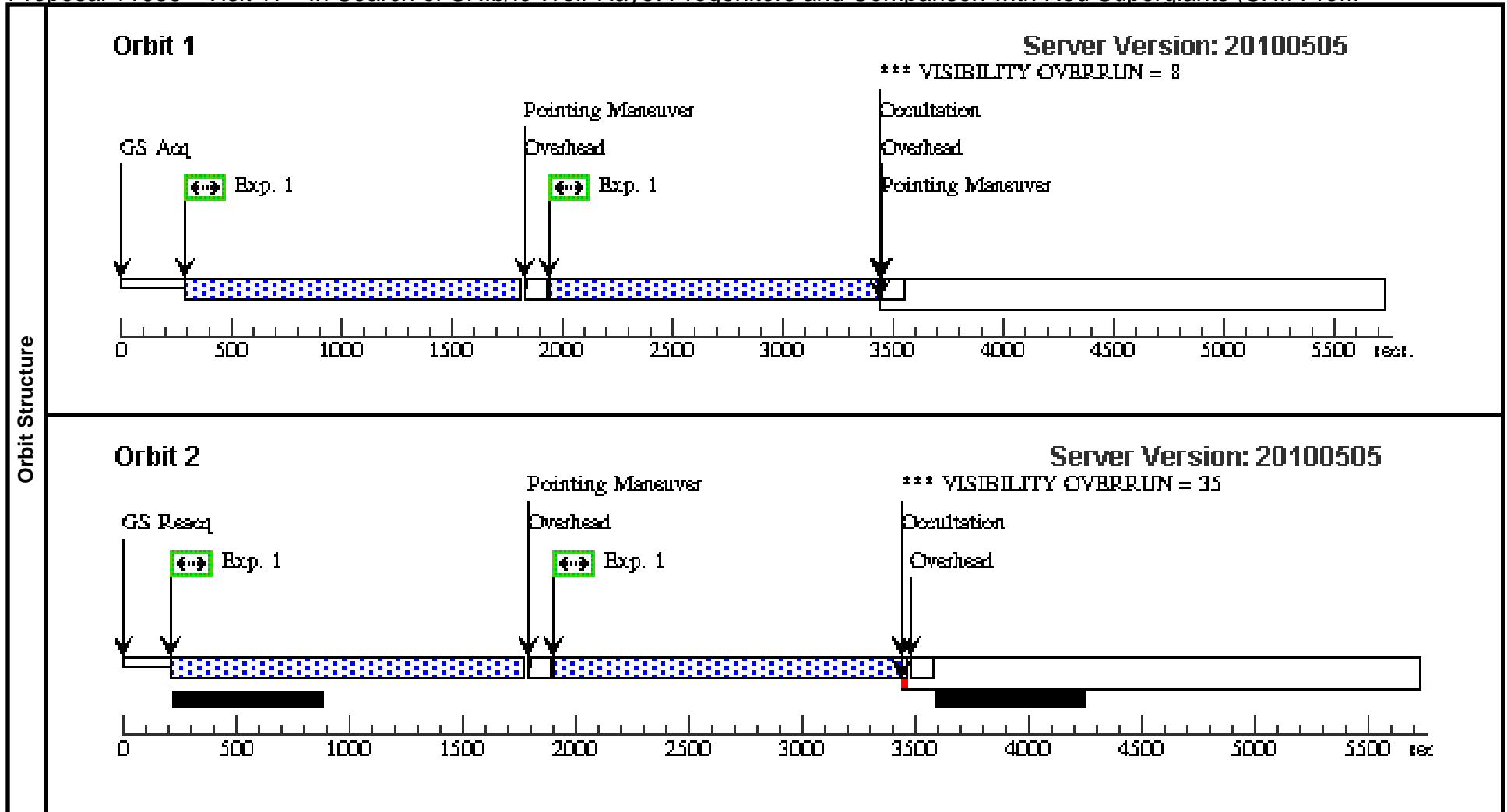

Proposal 11635 - Visit 17 - In Search of SNII/lc Wolf-Rayet Progenitors and Comparison with Red Supergiants (SNII Pro...

Fri Sep 17 01:01:56 GMT 2010

<b>Visit</b>	Proposal 11635, Visit 18, completed <b>Diagnostic Status: Warning</b> Scientific Instruments: WFC3/UVIS Special Requirements: ORIENT 201.0D TO 209.0 D										
	<b>Diagnostics</b>	(Visit 18) Warning (Orbit Planner): VISIBILITY OVERRUN (Visit 18) Warning (Orbit Planner): VISIBILITY OVERRUN									
<b>Patterns</b>		<b>#</b>	<b>Primary Pattern</b>				<b>Secondary Pattern</b>				<b>Exposures</b>
	(1)	Pattern Type=WFC3-UVIS-DITHER-BOX Purpose=DITHER Number Of Points=4 Point Spacing=0.173 Line Spacing=0.112				Coordinate Frame=POS-TARG Pattern Orientation=23.884 Angle Between Sides=81.785 Center Pattern=false				(1)	
<b>Fixed Targets</b>	<b>#</b>	<b>Name</b>	<b>Target Coordinates</b>		<b>Targ. Coord. Corrections</b>		<b>Fluxes</b>	<b>Miscellaneous</b>			
	(18)	M101-R	RA: 14 03 16.9455 (210.8206062d) Dec: +54 25 52.81 (54.43134d) Equinox: J2000				V=25	Reference Frame: xdss			
<b>Exposures</b>	<b>#</b>	<b>Label</b>	<b>Target</b>	<b>Config,Mode,Aperture</b>	<b>Spectral Els.</b>	<b>Opt. Params.</b>	<b>Special Reqs.</b>	<b>Groups</b>	<b>Exp. Time/[Actual Dur.]</b>		<b>Orbit</b>
	1	(18) M101-R		WFC3/UVIS, ACCUM, UVIS-CENTER	F469N	CR-SPLIT=NO		Pattern 1, Exps 1-1 (1)	1492 Secs		
									[=>(Pattern 1)]		[1]
									[=>1561 Secs (Pattern 3)]		[2]
								[=>1561 Secs (Pattern 4)]			

