



11718 - The Stellar Halos of Dwarf Galaxies

Cycle: 17, Proposal Category: GO

(Availability Mode: SUPPORTED)

INVESTIGATORS

<i>Name</i>	<i>Institution</i>	<i>E-Mail</i>
Dr. Julianne Dalcanton (PI)	University of Washington	jd@astro.washington.edu
Dr. Anil C. Seth (CoI)	Smithsonian Institution Astrophysical Observatory	aseth@cfa.harvard.edu
Dr. Benjamin F. Williams (CoI)	University of Washington	ben@astro.washington.edu
Ms. Karoline Gilbert (CoI)	University of California - Santa Cruz	kgilbert@ucolick.org

VISITS

<i>Visit</i>	<i>Targets used in Visit</i>	<i>Configurations used in Visit</i>	<i>Orbits Used</i>	<i>Last Orbit Planner Run</i>	<i>OP Current with Visit?</i>
01	(1) DDO-190-HALO1 ANY	ACS/WFC WFC3/UVIS	2	01-Aug-2008 21:13:51.0	yes
02	(2) DDO-190-HALO2 ANY	ACS/WFC WFC3/UVIS	2	01-Aug-2008 21:13:59.0	yes
03	(3) UGC-08505-HALO1 ANY	ACS/WFC WFC3/UVIS	2	01-Aug-2008 21:14:10.0	yes
04	(4) UGC-08505-HALO2 ANY	ACS/WFC WFC3/UVIS	2	01-Aug-2008 21:14:17.0	yes
05	(5) GR8-HALO1	ACS/WFC WFC3/UVIS	1	01-Aug-2008 21:14:23.0	yes

<i>Visit</i>	<i>Targets used in Visit</i>	<i>Configurations used in Visit</i>	<i>Orbits Used</i>	<i>Last Orbit Planner Run</i>	<i>OP Current with Visit?</i>
06	(6) GR8-HALO2	ACS/WFC WFC3/UVIS	1	01-Aug-2008 21:14:27.0	yes

10 Total Orbits Used

ABSTRACT

The metal-poor stellar halo is the oldest extended structure in the Galaxy. Such halos are thought to form through hierarchical merging, and contain stars pulled from accreted subhalos. The diffuse stellar halo therefore stores information about the properties of the accreted galaxies (i.e., their orbits, stellar masses, and metallicities). It is therefore unsurprising that stellar halos have become a popular probe of the early epoch of galaxy formation.

Almost all current work on stellar halos has focused on massive galaxies, however. We propose to extend the work on stellar halos to much lower mass scales, by studying the halos of faint dwarf galaxies. By taking halo studies into the dwarf galaxy regime, we can probe exceptionally small mass scales for the accreted halos. At these mass scales the effects of reionization and supernova feedback have the largest impact on the galaxy population. Stellar halos of dwarf galaxies are therefore a sensitive probe of the key processes needed to resolve the lack of substructure observed at low masses.

We are requesting two far-field ACS pointings for the three closest isolated nearby dwarf irregular galaxies whose inner halos have already been mapped with the ACS Nearby Galaxy Survey Treasury. These outer fields will allow us to trace the halo out to roughly half the virial radius, further than any previous study. We will use the resulting distribution of halo stars (1) to unambiguously measure the structure of the stellar halo, with minimal contamination from the main galaxy; (2) to constrain the flattening of the stellar halo; (3) to measure the metallicity of halo stars as a function of radius; (4) to correlate any changes in halo profile with changes in metallicity. The resulting data will constrain models of halo accretion and the epoch of reionization.

OBSERVING DESCRIPTION

We are taking ACS images in F475W+F814W at two pointings along the major and minor axes of three nearby dwarfs, targeting the outer regions where we expect to find halo stars. Parallel images will be taken with WFC3/UVIS in the same filter set. Images are CR split for DDO 190 and UGC 8508, with one filter per orbit (2 orbits total). For GR8 we have 1 orbit per pointing, and take two single dithered exposures in each filter. Exposure times for GR8 are split unevenly between the two filters to allow for maximum depth at the color of red clump stars.

Proposal 11718 - Visit 01 - The Stellar Halos of Dwarf Galaxies

Sat Aug 02 01:14:30 GMT 2008

Visit	Proposal 11718, Visit 01, implementation Diagnostic Status: No Diagnostics Scientific Instruments: ACS/WFC, WFC3/UVIS Special Requirements: ORIENT 155D TO 165 D Comments: 1 orbit per filter, ANGST style									
	Patterns	#	Primary Pattern			Secondary Pattern			Exposures	
		(1)	Pattern Type=ACS-WFC-DITHER-LINE Purpose=DITHER Number Of Points=3 Point Spacing=3.011 Line Spacing=	Coordinate Frame=POS-TARG Pattern Orientation=85.28 Angle Between Sides= Center Pattern=false					(1-2), (3-4)	
Fixed Targets	#	Name	Target Coordinates	Targ. Coord. Corrections	Fluxes	Miscellaneous				
	(1)	DDO-190-HALO1	RA: 14 25 1.0742 (216.2544758d) Dec: +44 32 39.57 (44.54432d) Equinox: J2000		V=13.3	Reference Frame: NED				
	Comments: This object was generated by the targetselector and retrieved from the NED database.									
Exposures	#	Label	Target	Config,Mode,Aperture	Spectral Els.	Opt. Params.	Special Reqs.	Groups	Exp. Time/[Actual Dur.]	Orbit
	1	DDO190-H ALO1 ACS F606W	(1) DDO-190-HALO 1	ACS/WFC, ACCUM, WFC	F475W	CR-SPLIT=NO		Pattern 1-2 (1) Prime + Parallel Group 1-2	824 Secs [=>(Pattern 1)] [=>(Pattern 2)] [=>(Pattern 3)]	[1]
	2	DDO190-H ALO1 UVIS F606W	ANY	WFC3/UVIS, ACCUM, UVIS	F475W	CR-SPLIT=NO		Pattern 1-2 (1) Prime + Parallel Group 1-2	860 Secs [=>860.0 Secs (Pattern 1)] [=>860.0 Secs (Pattern 2)] [=>860.0 Secs (Pattern 3)]	[1]
	3	DDO190-H ALO1 ACS F814W	(1) DDO-190-HALO 1	ACS/WFC, ACCUM, WFC	F814W	CR-SPLIT=NO		Pattern 3-4 (1) Prime + Parallel Group 3-4	879 Secs [=>884.0 Secs (Pattern 1)] [=>884.0 Secs (Pattern 2)] [=>884.0 Secs (Pattern 3)]	[2]
	4	DDO190-H ALO1 UVIS F814W	ANY	WFC3/UVIS, ACCUM, UVIS	F814W	CR-SPLIT=NO		Pattern 3-4 (1) Prime + Parallel Group 3-4	915 Secs [=>935.0 Secs (Pattern 1)] [=>915.0 Secs (Pattern 2)] [=>915.0 Secs (Pattern 3)]	[2]

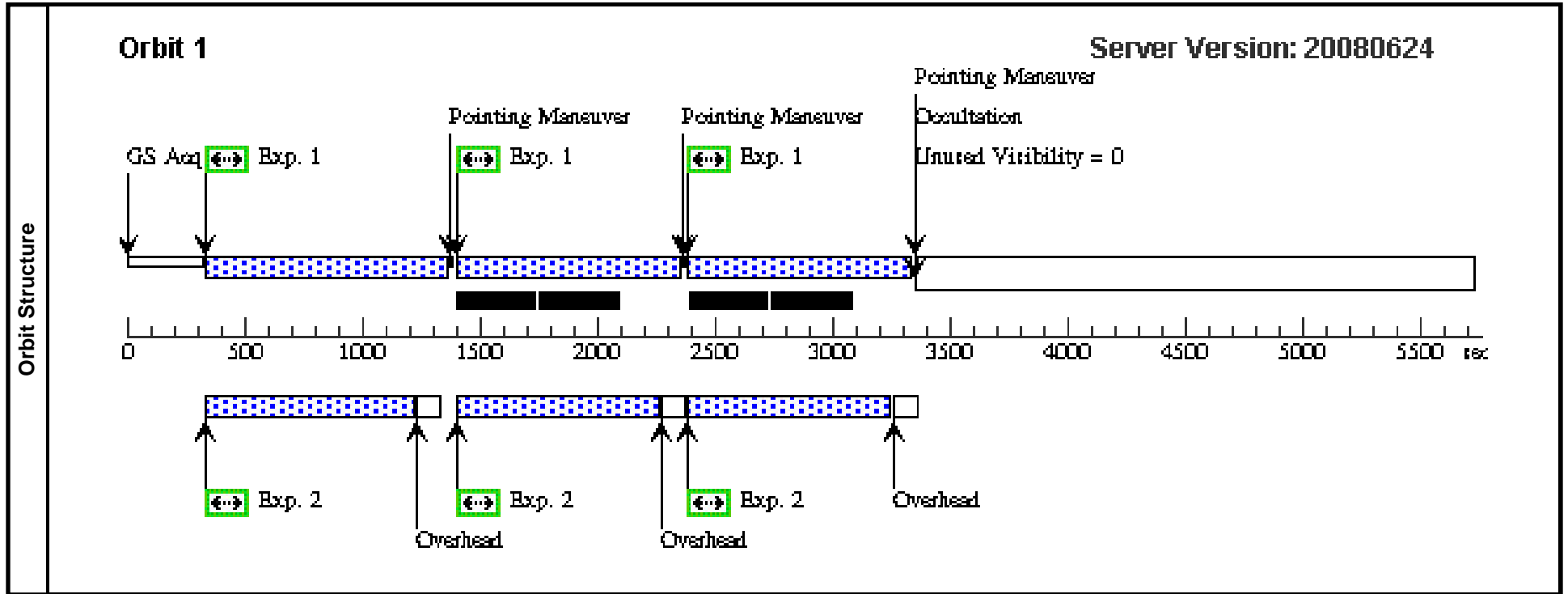

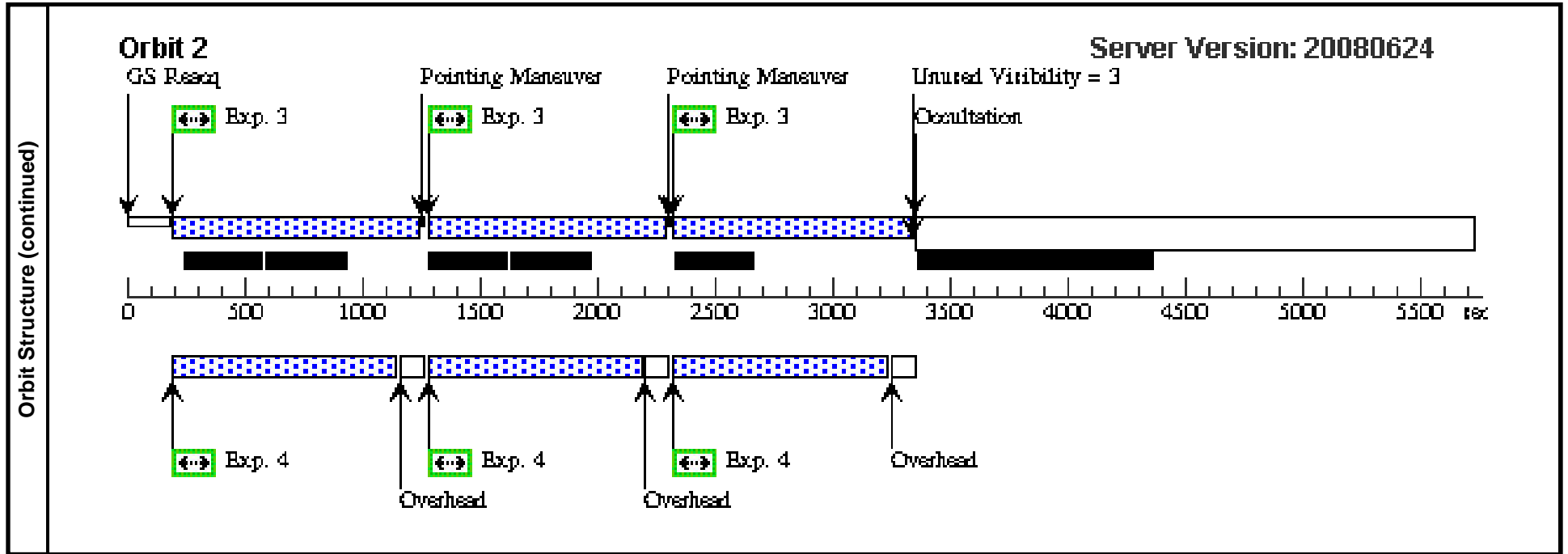

Proposal 11718 - Visit 02 - The Stellar Halos of Dwarf Galaxies

Sat Aug 02 01:14:32 GMT 2008

Visit	Proposal 11718, Visit 02, implementation Diagnostic Status: No Diagnostics Scientific Instruments: ACS/WFC, WFC3/UVIS Special Requirements: ORIENT 70D TO 80 D Comments: 1 orbit per filter, ANGST style									
	Patterns	#	Primary Pattern			Secondary Pattern			Exposures	
		(1)	Pattern Type=ACS-WFC-DITHER-LINE Purpose=DITHER Number Of Points=3 Point Spacing=3.011 Line Spacing=	Coordinate Frame=POS-TARG Pattern Orientation=85.28 Angle Between Sides= Center Pattern=false					(1-2), (3-4)	
Fixed Targets	#	Name	Target Coordinates	Targ. Coord. Corrections	Fluxes	Miscellaneous				
	(2)	DDO-190-HALO2	RA: 14 24 40.3004 (216.1679183d) Dec: +44 33 53.62 (44.56489d) Equinox: J2000		V=13.3	Reference Frame: NED				
	Comments: This object was generated by the targetselector and retrieved from the NED database.									
Exposures	#	Label	Target	Config,Mode,Aperture	Spectral Els.	Opt. Params.	Special Reqs.	Groups	Exp. Time/[Actual Dur.]	Orbit
	1	DDO190-H ALO2 ACS F606W	(2) DDO-190-HALO 2	ACS/WFC, ACCUM, WFC	F475W	CR-SPLIT=NO		Pattern 1-2 (1) Prime + Parallel Group 1-2	824 Secs [=>(Pattern 1)] [=>(Pattern 2)] [=>(Pattern 3)]	[1]
	2	DDO190-H ALO2 UVIS F606W	ANY	WFC3/UVIS, ACCUM, UVIS	F475W	CR-SPLIT=NO		Pattern 1-2 (1) Prime + Parallel Group 1-2	860 Secs [=>(Pattern 1)] [=>(Pattern 2)] [=>(Pattern 3)]	[1]
	3	DDO190-H ALO2 ACS F814W	(2) DDO-190-HALO 2	ACS/WFC, ACCUM, WFC	F814W	CR-SPLIT=NO		Pattern 3-4 (1) Prime + Parallel Group 3-4	879 Secs [=>(Pattern 1)] [=>(Pattern 2)] [=>(Pattern 3)]	[2]
	4	DDO190-H ALO2 UVIS F814W	ANY	WFC3/UVIS, ACCUM, UVIS	F814W	CR-SPLIT=NO		Pattern 3-4 (1) Prime + Parallel Group 3-4	915 Secs [=>(Pattern 1)] [=>(Pattern 2)] [=>(Pattern 3)]	[2]

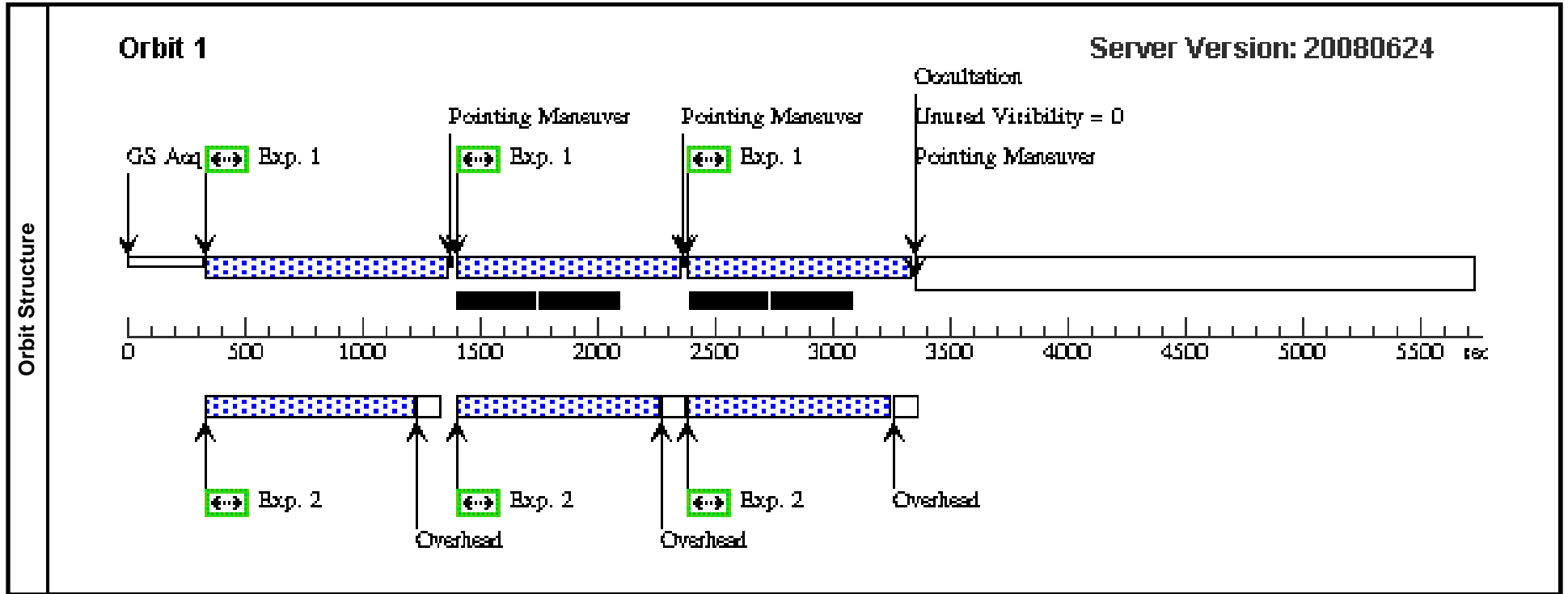

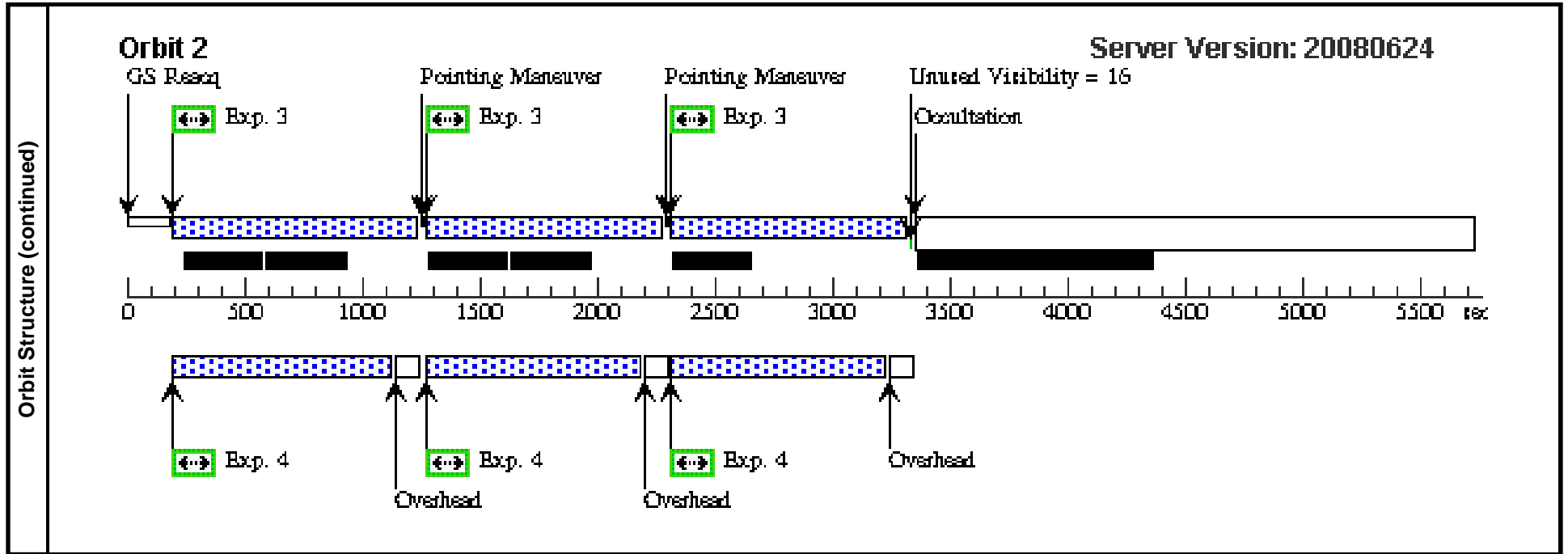

Proposal 11718 - Visit 03 - The Stellar Halos of Dwarf Galaxies

Sat Aug 02 01:14:32 GMT 2008

Visit	Proposal 11718, Visit 03, implementation Diagnostic Status: No Diagnostics Scientific Instruments: ACS/WFC, WFC3/UVIS Special Requirements: ORIENT 210D TO 220 D Comments: 1 orbit per filter, ANGST style									
	Patterns	#	Primary Pattern			Secondary Pattern			Exposures	
		(1)	Pattern Type=ACS-WFC-DITHER-LINE Purpose=DITHER Number Of Points=3 Point Spacing=3.011 Line Spacing=	Coordinate Frame=POS-TARG Pattern Orientation=85.28 Angle Between Sides= Center Pattern=false					(1-2), (3-4)	
Fixed Targets	#	Name	Target Coordinates	Targ. Coord. Corrections	Fluxes	Miscellaneous				
	(3)	UGC-08505-HALO1	RA: 13 30 59.5348 (202.7480617d) Dec: +54 56 58.24 (54.94951d) Equinox: J2000		V=14.4	Reference Frame: NED				
	Comments: This object was generated by the targetselector and retrieved from the NED database.									
Exposures	#	Label	Target	Config,Mode,Aperture	Spectral Els.	Opt. Params.	Special Reqs.	Groups	Exp. Time/[Actual Dur.]	Orbit
	1	UGC08505-HALO1 AC S F475W	(3) UGC-08505-HALO1	ACS/WFC, ACCUM, WFC	F475W	CR-SPLIT=NO		Pattern 1-2 (1) Prime + Parallel Group 1-2	855 Secs [=>(Pattern 1)] [=>(Pattern 2)] [=>(Pattern 3)]	[1]
	2	UGC08505-HALO1 UV IS F475W	ANY	WFC3/UVIS, ACCUM, UVIS	F475W	CR-SPLIT=NO		Pattern 1-2 (1) Prime + Parallel Group 1-2	900 Secs [=>(Pattern 1)] [=>(Pattern 2)] [=>(Pattern 3)]	[1]
	3	UGC08505-HALO1 AC S F814W	(3) UGC-08505-HALO1	ACS/WFC, ACCUM, WFC	F814W	CR-SPLIT=NO		Pattern 3-4 (1) Prime + Parallel Group 3-4	915 Secs [=>(Pattern 1)] [=>(Pattern 2)] [=>(Pattern 3)]	[2]
	4	UGC08505-HALO1 UV IS F814W	ANY	WFC3/UVIS, ACCUM, UVIS	F814W	CR-SPLIT=NO		Pattern 3-4 (1) Prime + Parallel Group 3-4	961 Secs [=>(Pattern 1)] [=>(Pattern 2)] [=>(Pattern 3)]	[2]

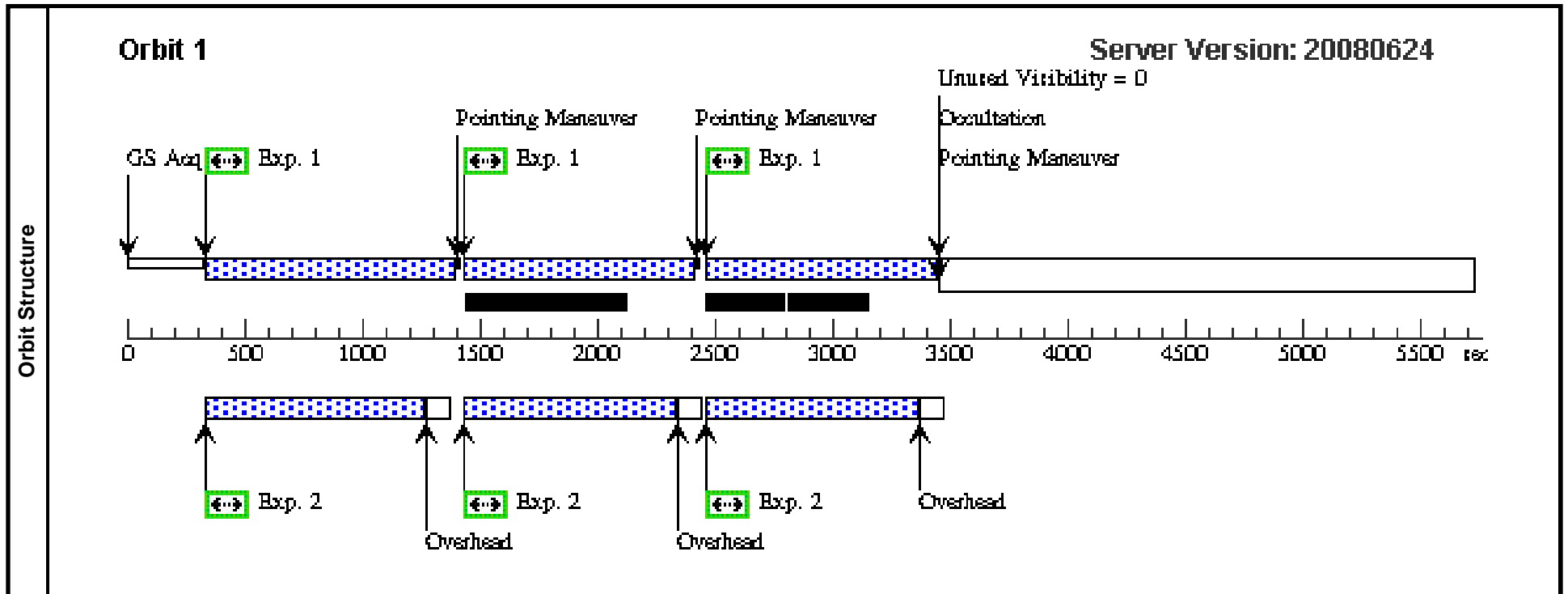

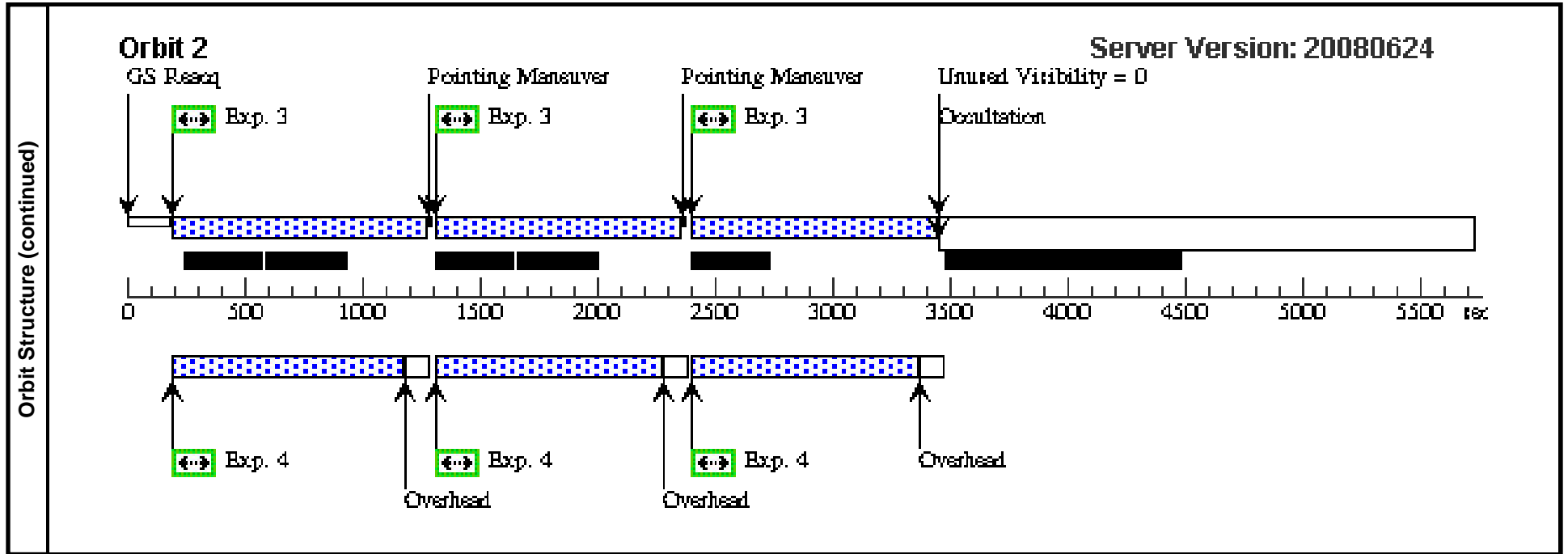

Proposal 11718 - Visit 04 - The Stellar Halos of Dwarf Galaxies

Sat Aug 02 01:14:33 GMT 2008

Visit	Proposal 11718, Visit 04, implementation Diagnostic Status: No Diagnostics Scientific Instruments: ACS/WFC, WFC3/UVIS Special Requirements: SAME ORIENT AS 03 Comments: 1 orbit per filter, ANGST style									
	Patterns	#	Primary Pattern			Secondary Pattern			Exposures	
		(1)	Pattern Type=ACS-WFC-DITHER-LINE Purpose=DITHER Number Of Points=3 Point Spacing=3.011 Line Spacing=	Coordinate Frame=POS-TARG Pattern Orientation=85.28 Angle Between Sides= Center Pattern=false					(1-2), (3-4)	
Fixed Targets	#	Name	Target Coordinates	Targ. Coord. Corrections	Fluxes	Miscellaneous				
	(4)	UGC-08505-HALO2	RA: 13 31 5.6961 (202.7737338d) Dec: +54 52 38.43 (54.87734d) Equinox: J2000		V=14.4	Reference Frame: NED				
	Comments: This object was generated by the targetselector and retrieved from the NED database.									
Exposures	#	Label	Target	Config,Mode,Aperture	Spectral Els.	Opt. Params.	Special Reqs.	Groups	Exp. Time/[Actual Dur.]	Orbit
	1	UGC08505-HALO2 AC S F475W	(4) UGC-08505-HALO2	ACS/WFC, ACCUM, WFC	F475W	CR-SPLIT=NO		Pattern 1-2 (1) Prime + Parallel Group 1-2	855 Secs [=>(Pattern 1)] [=>(Pattern 2)] [=>(Pattern 3)]	[1]
	2	UGC08505-HALO2 UV IS F475W	ANY	WFC3/UVIS, ACCUM, UVIS	F475W	CR-SPLIT=NO		Pattern 1-2 (1) Prime + Parallel Group 1-2	900 Secs [=>(Pattern 1)] [=>(Pattern 2)] [=>(Pattern 3)]	[1]
	3	UGC08505-HALO2 AC S F814W	(4) UGC-08505-HALO2	ACS/WFC, ACCUM, WFC	F814W	CR-SPLIT=NO		Pattern 3-4 (1) Prime + Parallel Group 3-4	915 Secs [=>(Pattern 1)] [=>(Pattern 2)] [=>(Pattern 3)]	[2]
	4	UGC08505-HALO2 UV IS F814W	ANY	WFC3/UVIS, ACCUM, UVIS	F814W	CR-SPLIT=NO		Pattern 3-4 (1) Prime + Parallel Group 3-4	961 Secs [=>(Pattern 1)] [=>(Pattern 2)] [=>(Pattern 3)]	[2]

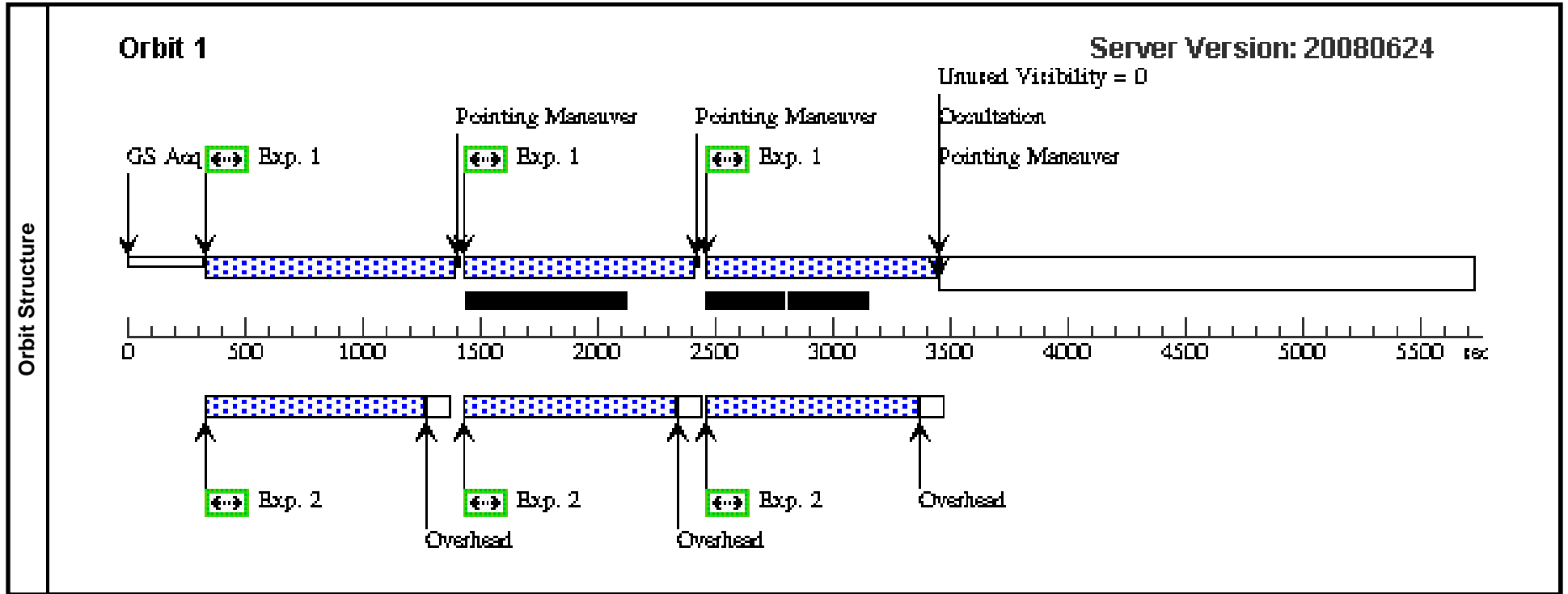

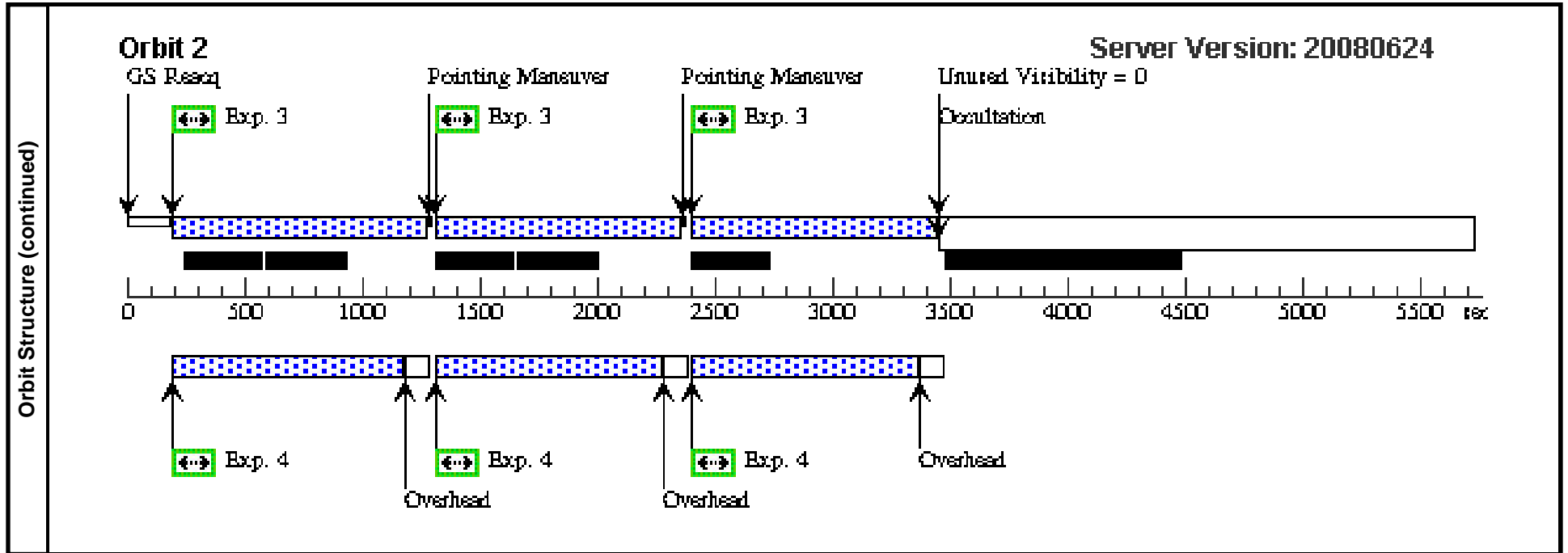

Proposal 11718 - Visit 05 - The Stellar Halos of Dwarf Galaxies

Sat Aug 02 01:14:33 GMT 2008

Visit	Proposal 11718, Visit 05, implementation Diagnostic Status: No Diagnostics Scientific Instruments: ACS/WFC, WFC3/UVIS Special Requirements: ORIENT 285D TO 295 D Comments: 1 orbit for the whole target.									
	Fixed Targets	#	Name	Target Coordinates	Targ. Coord. Corrections	Fluxes	Miscellaneous			
	(5)	GR8-HALO1	RA: 12 58 37.2753 (194.6553138d) Dec: +14 10 6.50 (14.16847d) Equinox: J2000			V=14.7	Reference Frame: NED	Comments: This object was generated by the targetselector and retrieved from the NED database.		
Exposures	#	Label	Target	Config,Mode,Aperture	Spectral Els.	Opt. Params.	Special Reqs.	Groups	Exp. Time/[Actual Dur.]	Orbit
	1	GR8-HALO 1 ACS F814 W	(5) GR8-HALO1	ACS/WFC, ACCUM, WFC	F814W	CR-SPLIT=NO	GS ACQ SCENARI O BASE1B3	Prime + Parallel Gro up 1-2	400 Secs [==>375.0 Secs]	[1]
	2	GR8-HALO 1 UVIS F81 4W	(5) GR8-HALO1	WFC3/UVIS, ACCUM, UVIS	F814W	CR-SPLIT=NO		Prime + Parallel Gro up 1-2	450 Secs [==>450.0 Secs]	[1]
	3	GR8-HALO 1 ACS F475 W	(5) GR8-HALO1	ACS/WFC, ACCUM, WFC	F475W	CR-SPLIT=NO		Prime + Parallel Gro up 3-4	720 Secs [==>695.0 Secs]	[1]
	4	GR8-HALO 1 UVIS F47 5W	(5) GR8-HALO1	WFC3/UVIS, ACCUM, UVIS	F475W	CR-SPLIT=NO		Prime + Parallel Gro up 3-4	730 Secs [==>730.0 Secs]	[1]
	5	GR8-HALO 1 ACS F475 W	(5) GR8-HALO1	ACS/WFC, ACCUM, WFC	F475W	CR-SPLIT=NO	POS TARG 0.1482,0 .1602	Prime + Parallel Gro up 5-6	720 Secs [==>695.0 Secs]	[1]
	6	GR8-HALO 1 UVIS F47 5W	(5) GR8-HALO1	WFC3/UVIS, ACCUM, UVIS	F475W	CR-SPLIT=NO		Prime + Parallel Gro up 5-6	730 Secs [==>730.0 Secs]	[1]
	7	GR8-HALO 1 ACS F814 W	(5) GR8-HALO1	ACS/WFC, ACCUM, WFC	F814W	CR-SPLIT=NO	SAME POS AS 5	Prime + Parallel Gro up 7-8	400 Secs [==>375.0 Secs]	[1]
8	GR8-HALO 1 UVIS F81 4W	(5) GR8-HALO1	WFC3/UVIS, ACCUM, UVIS	F814W	CR-SPLIT=NO		Prime + Parallel Gro up 7-8	450 Secs [==>450.0 Secs]	[1]	

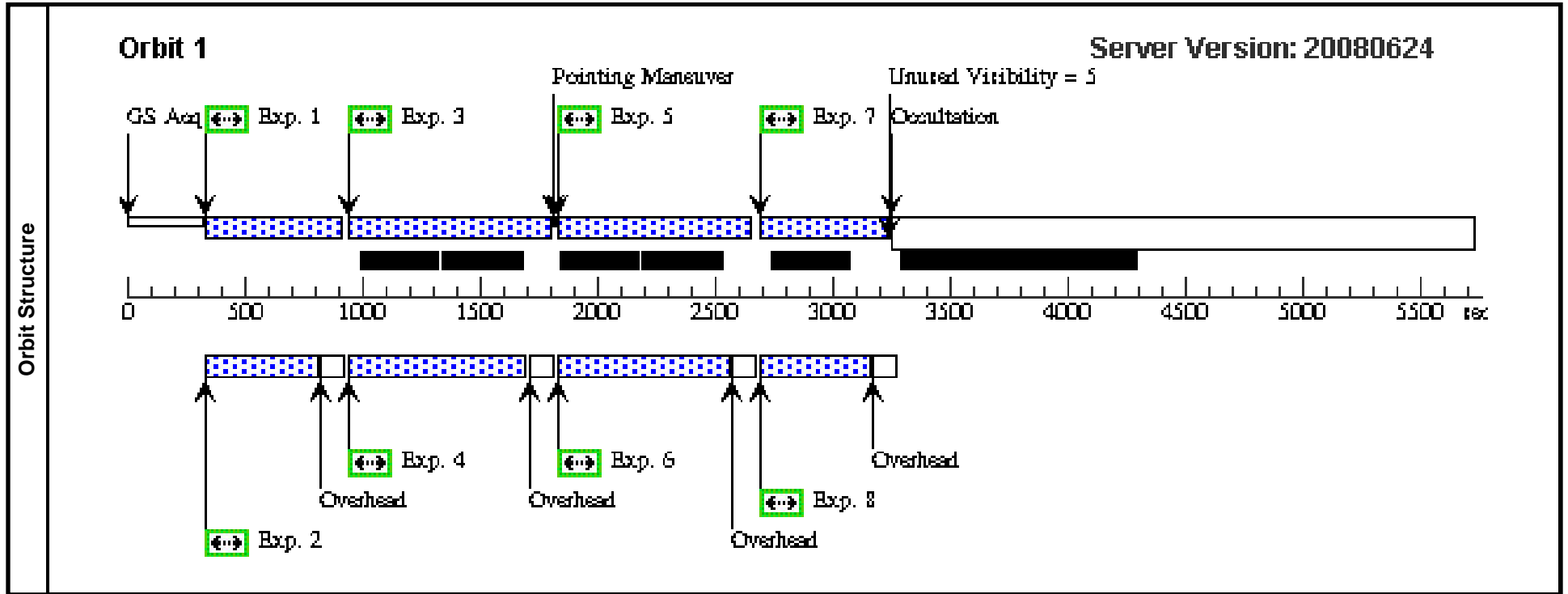

Proposal 11718 - Visit 06 - The Stellar Halos of Dwarf Galaxies

Sat Aug 02 01:14:34 GMT 2008

Visit	Proposal 11718, Visit 06, implementation Diagnostic Status: No Diagnostics Scientific Instruments: ACS/WFC, WFC3/UVIS Special Requirements: SAME ORIENT AS 05 Comments: 1 orbit for the whole target.									
	Fixed Targets	#	Name	Target Coordinates	Targ. Coord. Corrections	Fluxes	Miscellaneous			
	(6)	GR8-HALO2	RA: 12 58 54.3342 (194.7263925d) Dec: +14 11 19.87 (14.18885d) Equinox: J2000		V=14.7	Reference Frame: NED				
	Comments: This object was generated by the targetselector and retrieved from the NED database.									
Exposures	#	Label	Target	Config,Mode,Aperture	Spectral Els.	Opt. Params.	Special Reqs.	Groups	Exp. Time/[Actual Dur.]	Orbit
	1	GR8-HALO 2 ACS F814 W	(6) GR8-HALO2	ACS/WFC, ACCUM, WFC	F814W	CR-SPLIT=NO	GS ACQ SCENARI O BASE1B3	Prime + Parallel Gro up 1-2	400 Secs [==>375.0 Secs]	[1]
	2	GR8-HALO 2 UVIS F81 4W	(6) GR8-HALO2	WFC3/UVIS, ACCUM, UVIS	F814W	CR-SPLIT=NO		Prime + Parallel Gro up 1-2	450 Secs [==>450.0 Secs]	[1]
	3	GR8-HALO 2 ACS F475 W	(6) GR8-HALO2	ACS/WFC, ACCUM, WFC	F475W	CR-SPLIT=NO		Prime + Parallel Gro up 3-4	720 Secs [==>695.0 Secs]	[1]
	4	GR8-HALO 2 UVIS F47 5W	(6) GR8-HALO2	WFC3/UVIS, ACCUM, UVIS	F475W	CR-SPLIT=NO		Prime + Parallel Gro up 3-4	730 Secs [==>730.0 Secs]	[1]
	5	GR8-HALO 2 ACS 475 W	(6) GR8-HALO2	ACS/WFC, ACCUM, WFC	F475W	CR-SPLIT=NO	POS TARG 0.1482,0 .1602	Prime + Parallel Gro up 5-6	720 Secs [==>695.0 Secs]	[1]
	6	GR8-HALO 2 UVIS F47 5W	(6) GR8-HALO2	WFC3/UVIS, ACCUM, UVIS	F475W	CR-SPLIT=NO		Prime + Parallel Gro up 5-6	730 Secs [==>730.0 Secs]	[1]
	7	GR8-HALO 2 ACS F814 W	(6) GR8-HALO2	ACS/WFC, ACCUM, WFC	F814W	CR-SPLIT=NO	SAME POS AS 5	Prime + Parallel Gro up 7-8	400 Secs [==>375.0 Secs]	[1]
	8	GR8-HALO 2 UVIS F81 4W	(6) GR8-HALO2	WFC3/UVIS, ACCUM, UVIS	F814W	CR-SPLIT=NO		Prime + Parallel Gro up 7-8	450 Secs [==>450.0 Secs]	[1]

