



12962 - Optical Line Emission Impact Polarization: SN1006

Cycle: 20, Proposal Category: GO

(Availability Mode: AVAILABLE)

INVESTIGATORS

<i>Name</i>	<i>Institution</i>	<i>E-Mail</i>
Dr. William B. Sparks (PI) (Contact)	Space Telescope Science Institute	sparks@stsci.edu
Dr. Robert F. Carswell (CoI) (ESA Member)	University of Cambridge	rfc@ast.cam.ac.uk
Dr. Knox S. Long (CoI)	Space Telescope Science Institute	long@stsci.edu
Dr. James E. Pringle (CoI) (ESA Member)	University of Cambridge	jep@ast.cam.ac.uk
Dr. Megan Donahue (CoI)	Michigan State University	donahue@pa.msu.edu
Dr. Jim Hough (CoI) (ESA Member)	University of Hertfordshire	jhh@star.herts.ac.uk
Nadine Manset (CoI)	Canada-France-Hawaii Telescope Corporation	manset@cfht.hawaii.edu

VISITS

<i>Visit</i>	<i>Targets used in Visit</i>	<i>Configurations used in Visit</i>	<i>Orbits Used</i>	<i>Last Orbit Planner Run</i>	<i>OP Current with Visit?</i>
01	(1) SN1006-NW ANY	ACS/WFC WFC3/UVIS	3	24-May-2013 21:20:54.0	yes
02	(1) SN1006-NW ANY	ACS/WFC WFC3/UVIS	3	24-May-2013 21:21:12.0	yes
03	(1) SN1006-NW ANY	ACS/WFC WFC3/UVIS	3	24-May-2013 21:21:28.0	yes
04	(1) SN1006-NW ANY	ACS/WFC WFC3/IR	3	24-May-2013 21:21:44.0	yes
54	(1) SN1006-NW ANY	ACS/WFC WFC3/IR	3	24-May-2013 21:22:02.0	yes

15 Total Orbits Used

ABSTRACT

We propose to probe the physics of shocks and transport processes by seeking the intrinsic line emission polarization predicted to be present in the classical non-radiative fast-shock remnant of SN1006. The prediction, Laming (1990), is that the narrow Balmer line core of the 2000 km/s shock in SN1006 will be polarized in the range 5-10% and that the broad wings will be unpolarized. The polarization is sensitive to shock velocity and ionization equilibrium. By measuring polarization for SN1006 we validate and enable a completely new diagnostic that has important applications in a wide variety of astrophysical situations involving anisotropic excitation mechanisms in general, such as shocks, intense radiation fields, high energy particle streams and conductive interfaces along with a substantial body of theoretical work that cuts across disciplines in this area. We also apply this diagnostic directly to the case of SN1006 and determine if our current theoretical expectations based on inferences on the shock velocity and structure are fulfilled. The observations will yield a spectacularly precise measurement of the proper motion distribution in the filaments of SN1006 and allow a direct estimate of its deceleration.

OBSERVING DESCRIPTION

We will image the emission filaments of SN 1006 using the ACS H α filter together with the ACS polarizers. In parallel we will obtain WFC3 images. Each orbit is at a slightly different pointing to achieve effective dithering between similar images.

Proposal 12962 - Visit 01 - Optical Line Emission Impact Polarization: SN1006

Sat May 25 01:22:12 GMT 2013

Visit	Proposal 12962, Visit 01, completed Diagnostic Status: Warning Scientific Instruments: WFC3/UVIS, ACS/WFC Special Requirements: ORIENT 356.47D TO 6.47 D									
	Diagnostics	(Visit 01) Warning (Orbit Planner): SAME POS MAY NOT BE APPROPRIATE (Visit 01) Warning (Orbit Planner): SAME POS MAY NOT BE APPROPRIATE (Visit 01) Warning (Orbit Planner): SAME POS MAY NOT BE APPROPRIATE (Visit 01) Warning (Orbit Planner): SAME POS MAY NOT BE APPROPRIATE								
Fixed Targets		#	Name	Target Coordinates	Targ. Coord. Corrections	Fluxes	Miscellaneous			
		(1)	SN1006-NW	RA: 15 02 16.1510 (225.5672958d) Dec: -41 45 2.60 (-41.75072d) Equinox: J2000	Proper Motion RA: -0.015 sec of time/yr Proper Motion Dec: 0.223 arcsec/yr Parallax: 0.0" Epoch of Position: 2013 Radial Velocity: 0.0 km/sec	V=(?) Halpna surface brightness 5.3e-1 6 erg/s/cm2/arcsec	Reference Frame: ACS image j9c391919_drz			
<i>Comments: Proper motion for Region E of Winkler et al 2003 ApJ 585, 324.</i>										
Exposures	#	Label	Target	Config,Mode,Aperture	Spectral Els.	Opt. Params.	Special Reqs.	Groups	Exp. Time/[Actual Dur.]	Orbit
	1	(1) SN1006-NW	ACS/WFC, ACCUM, WFC	F658N POL0V				Prime + Parallel Gro up 1-4 in Visit 01	770 Secs [==>]	[1]
	2	(1) SN1006-NW	ACS/WFC, ACCUM, WFC	F658N POL60V				Prime + Parallel Gro up 1-4 in Visit 01	770 Secs [==>]	[1]
	3	(1) SN1006-NW	ACS/WFC, ACCUM, WFC	F658N POL120V				Prime + Parallel Gro up 1-4 in Visit 01	770 Secs [==>]	[1]
	4	ANY	WFC3/UVIS, ACCUM, UVIS	F657N	CR-SPLIT=2; FLASH=5			Prime + Parallel Gro up 1-4 in Visit 01	2800 Secs [==>(Split 1)] [==>(Split 2)]	[1]
	5	(1) SN1006-NW	ACS/WFC, ACCUM, WFC	F658N POL0V			POS TARG 0.247,0. 094	Prime + Parallel Gro up 5-8 in Visit 01	820 Secs [==>]	[2]
	6	(1) SN1006-NW	ACS/WFC, ACCUM, WFC	F658N POL60V			SAME POS AS 5	Prime + Parallel Gro up 5-8 in Visit 01	820 Secs [==>]	[2]
	7	(1) SN1006-NW	ACS/WFC, ACCUM, WFC	F658N POL120V			SAME POS AS 5	Prime + Parallel Gro up 5-8 in Visit 01	820 Secs [==>]	[2]
	8	ANY	WFC3/UVIS, ACCUM, UVIS	F657N	CR-SPLIT=2; FLASH=5			Prime + Parallel Gro up 5-8 in Visit 01	2950 Secs [==>(Split 1)] [==>(Split 2)]	[2]
	9	(1) SN1006-NW	ACS/WFC, ACCUM, WFC	F658N POL0V			POS TARG 0.124,0. 232	Prime + Parallel Gro up 9-12 in Visit 01	820 Secs [==>]	[3]
	10	(1) SN1006-NW	ACS/WFC, ACCUM, WFC	F658N POL60V			SAME POS AS 9	Prime + Parallel Gro up 9-12 in Visit 01	820 Secs [==>]	[3]
	11	(1) SN1006-NW	ACS/WFC, ACCUM, WFC	F658N POL120V			SAME POS AS 9	Prime + Parallel Gro up 9-12 in Visit 01	820 Secs [==>]	[3]
	12	ANY	WFC3/UVIS, ACCUM, UVIS	F657N	CR-SPLIT=2; FLASH=5			Prime + Parallel Gro up 9-12 in Visit 01	2950 Secs [==>(Split 1)] [==>(Split 2)]	[3]

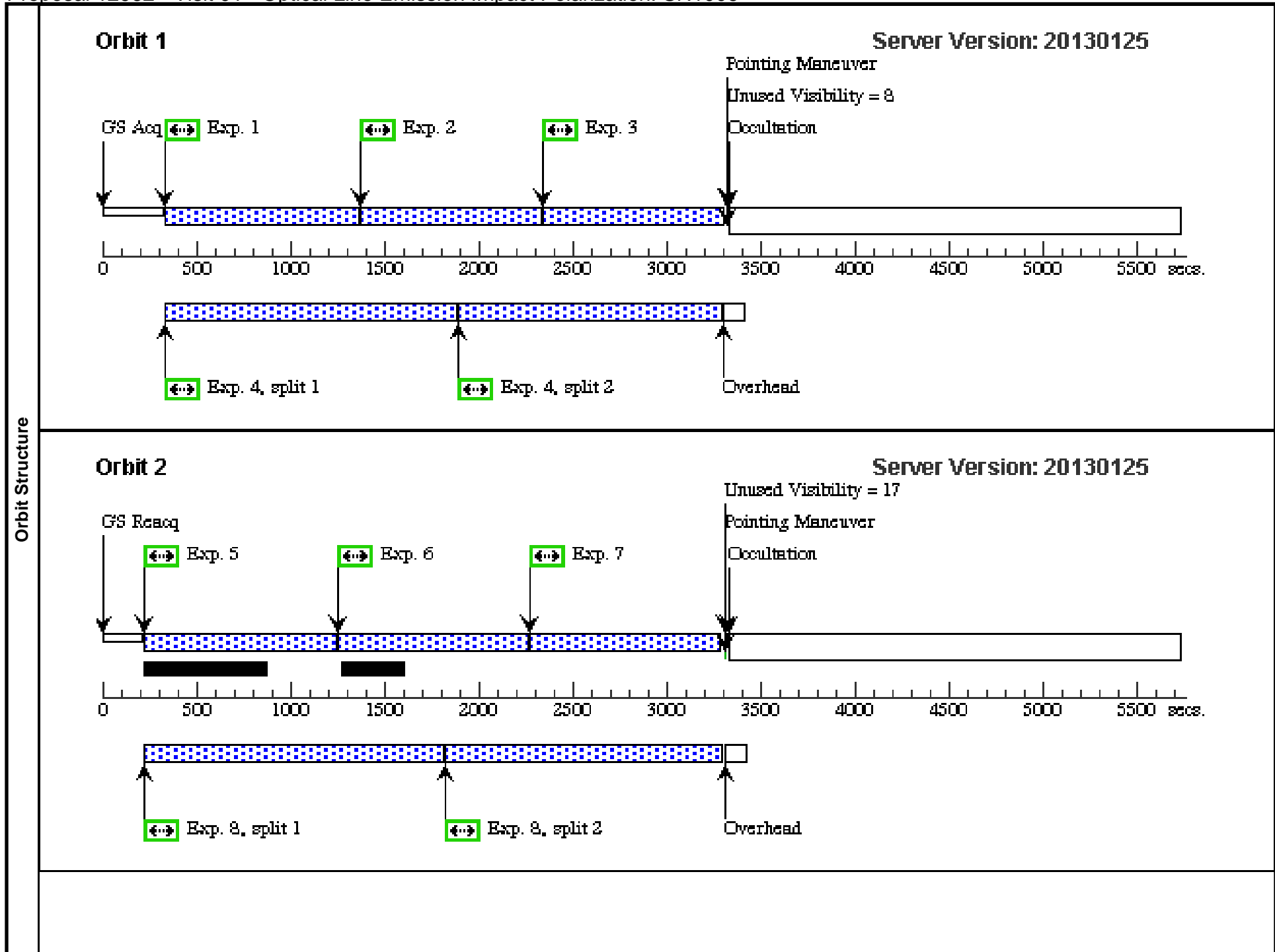

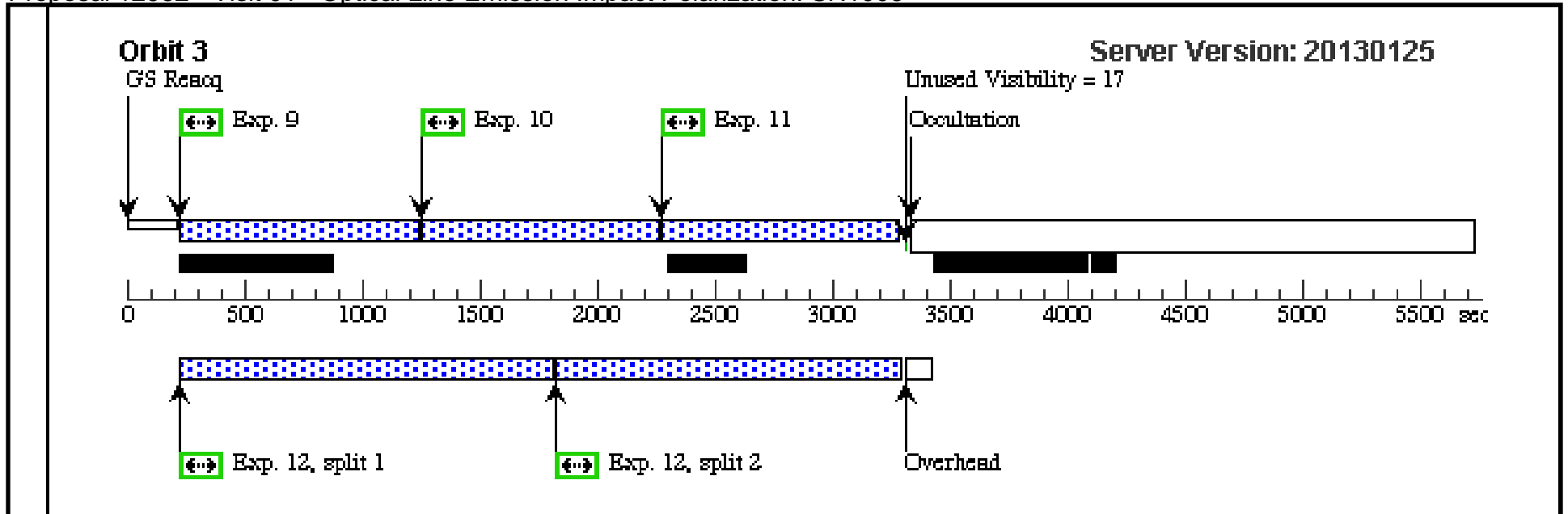

Proposal 12962 - Visit 02 - Optical Line Emission Impact Polarization: SN1006

Sat May 25 01:22:16 GMT 2013

Visit	Proposal 12962, Visit 02, completed Diagnostic Status: Warning Scientific Instruments: WFC3/UVIS, ACS/WFC Special Requirements: SAME ORIENT AS 01; GROUP 02,01,03,04 WITHIN 13D									
	(Visit 02) Warning (Orbit Planner): SAME POS MAY NOT BE APPROPRIATE (Visit 02) Warning (Orbit Planner): SAME POS MAY NOT BE APPROPRIATE (Visit 02) Warning (Orbit Planner): SAME POS MAY NOT BE APPROPRIATE (Visit 02) Warning (Orbit Planner): SAME POS MAY NOT BE APPROPRIATE (Visit 02) Warning (Orbit Planner): SAME POS MAY NOT BE APPROPRIATE (Visit 02) Warning (Orbit Planner): SAME POS MAY NOT BE APPROPRIATE									
Fixed Targets	#	Name	Target Coordinates	Targ. Coord. Corrections		Fluxes	Miscellaneous			
	(1)	SN1006-NW	RA: 15 02 16.1510 (225.5672958d) Dec: -41 45 2.60 (-41.75072d) Equinox: J2000	Proper Motion RA: -0.015 sec of time/yr Proper Motion Dec: 0.223 arcsec/yr Parallax: 0.0" Epoch of Position: 2013 Radial Velocity: 0.0 km/sec	V=(?) Halpaha surface brightness 5.3e-1 6 erg/s/cm2/arcsec	Reference Frame: ACS image j9c391919_drz				
<i>Comments: Proper motion for Region E of Winkler et al 2003 ApJ 585, 324.</i>										
Exposures	#	Label	Target	Config,Mode,Aperture	Spectral Els.	Opt. Params.	Special Reqs.	Groups	Exp. Time/[Actual Dur.]	Orbit
	1	(1) SN1006-NW	ACS/WFC, ACCUM, WFC	F658N POL0V	POS TARG -0.124,0 .138	Prime + Parallel Gro up 1-4 in Visit 02	770 Secs [==>]	[1]		
	2	(1) SN1006-NW	ACS/WFC, ACCUM, WFC	F658N POL60V	SAME POS AS 1	Prime + Parallel Gro up 1-4 in Visit 02	770 Secs [==>]	[1]		
	3	(1) SN1006-NW	ACS/WFC, ACCUM, WFC	F658N POL120V	SAME POS AS 1	Prime + Parallel Gro up 1-4 in Visit 02	770 Secs [==>]	[1]		
	4	ANY	WFC3/UVIS, ACCUM, UVIS	F657N	CR-SPLIT=2; FLASH=5	Prime + Parallel Gro up 1-4 in Visit 02	2800 Secs [==>(Split 1)] [==>(Split 2)]	[1]		
	5	(1) SN1006-NW	ACS/WFC, ACCUM, WFC	F658N POL0V	POS TARG -0.124,- 0.141	Prime + Parallel Gro up 5-8 in Visit 02	820 Secs [==>]	[2]		
	6	(1) SN1006-NW	ACS/WFC, ACCUM, WFC	F658N POL60V	SAME POS AS 5	Prime + Parallel Gro up 5-8 in Visit 02	820 Secs [==>]	[2]		
	7	(1) SN1006-NW	ACS/WFC, ACCUM, WFC	F658N POL120V	SAME POS AS 5	Prime + Parallel Gro up 5-8 in Visit 02	820 Secs [==>]	[2]		
	8	ANY	WFC3/UVIS, ACCUM, UVIS	F657N	CR-SPLIT=2; FLASH=5	Prime + Parallel Gro up 5-8 in Visit 02	2800 Secs [==>(Split 1)] [==>(Split 2)]	[2]		
	9	(1) SN1006-NW	ACS/WFC, ACCUM, WFC	F658N POL0V	POS TARG 0.124,-0 .047	Prime + Parallel Gro up 9-12 in Visit 02	820 Secs [==>]	[3]		
	10	(1) SN1006-NW	ACS/WFC, ACCUM, WFC	F658N POL60V	SAME POS AS 9	Prime + Parallel Gro up 9-12 in Visit 02	820 Secs [==>]	[3]		
	11	(1) SN1006-NW	ACS/WFC, ACCUM, WFC	F658N POL120V	SAME POS AS 9	Prime + Parallel Gro up 9-12 in Visit 02	820 Secs [==>]	[3]		
12	ANY	WFC3/UVIS, ACCUM, UVIS	F657N	CR-SPLIT=2; FLASH=5	Prime + Parallel Gro up 9-12 in Visit 02	2800 Secs [==>(Split 1)] [==>(Split 2)]	[3]			

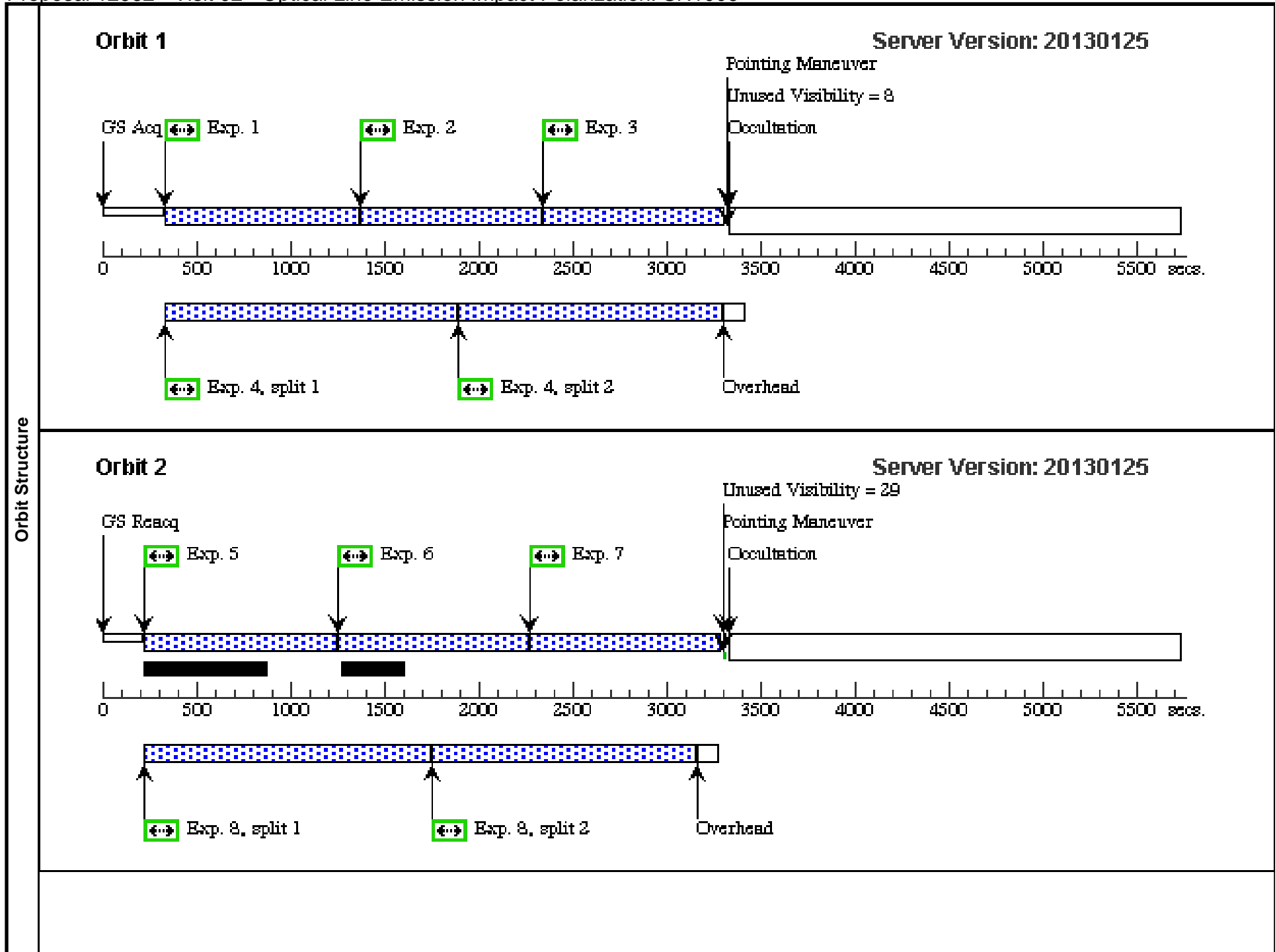

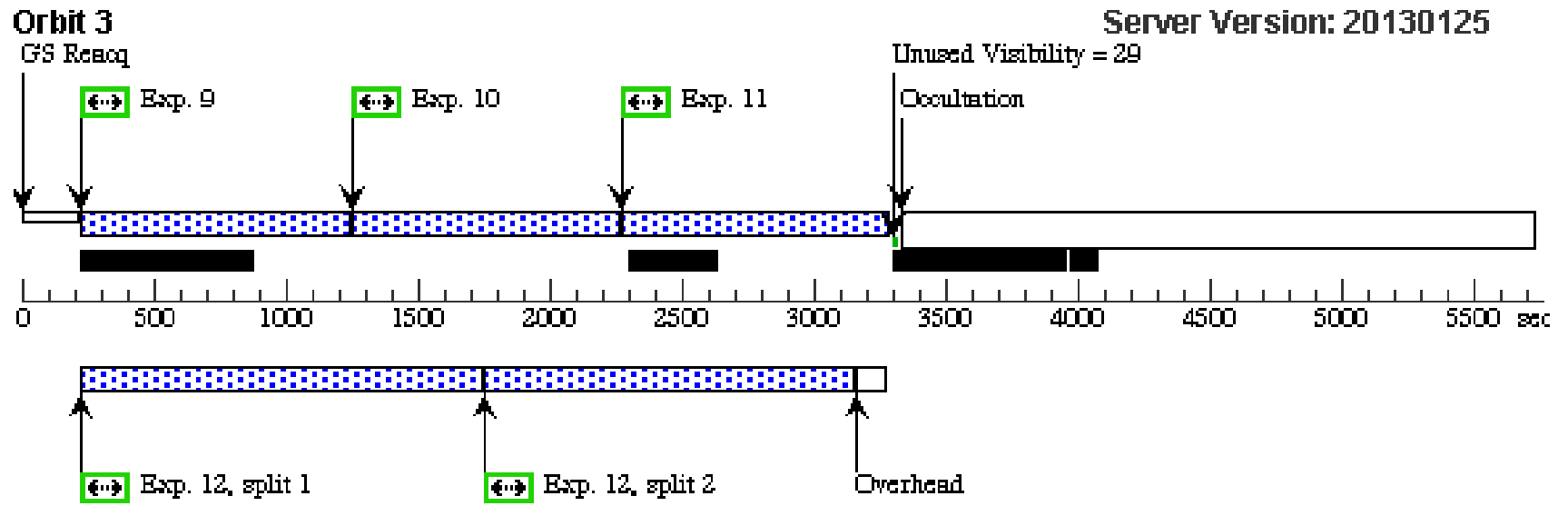

Proposal 12962 - Visit 03 - Optical Line Emission Impact Polarization: SN1006

Sat May 25 01:22:20 GMT 2013

Visit	Proposal 12962, Visit 03, completed Diagnostic Status: Warning Scientific Instruments: WFC3/UVIS, ACS/WFC Special Requirements: SAME ORIENT AS 01																																																																																																																																											
Diagnostics	(Visit 03) Warning (Orbit Planner): SAME POS MAY NOT BE APPROPRIATE (Visit 03) Warning (Orbit Planner): SAME POS MAY NOT BE APPROPRIATE (Visit 03) Warning (Orbit Planner): SAME POS MAY NOT BE APPROPRIATE (Visit 03) Warning (Orbit Planner): SAME POS MAY NOT BE APPROPRIATE (Visit 03) Warning (Orbit Planner): SAME POS MAY NOT BE APPROPRIATE (Visit 03) Warning (Orbit Planner): SAME POS MAY NOT BE APPROPRIATE																																																																																																																																											
Fixed Targets	<table border="1"> <thead> <tr> <th>#</th> <th>Name</th> <th>Target Coordinates</th> <th>Targ. Coord. Corrections</th> <th>Fluxes</th> <th>Miscellaneous</th> </tr> </thead> <tbody> <tr> <td>(1)</td> <td>SN1006-NW</td> <td>RA: 15 02 16.1510 (225.5672958d) Dec: -41 45 2.60 (-41.75072d) Equinox: J2000</td> <td>Proper Motion RA: -0.015 sec of time/yr Proper Motion Dec: 0.223 arcsec/yr Parallax: 0.0" Epoch of Position: 2013 Radial Velocity: 0.0 km/sec</td> <td>V=(?) Halpna surface brightness 5.3e-1 6 erg/s/cm2/arcsec</td> <td>Reference Frame: ACS image j9c391919_drz</td> </tr> </tbody> </table> <p><i>Comments: Proper motion for Region E of Winkler et al 2003 ApJ 585, 324.</i></p>										#	Name	Target Coordinates	Targ. Coord. Corrections	Fluxes	Miscellaneous	(1)	SN1006-NW	RA: 15 02 16.1510 (225.5672958d) Dec: -41 45 2.60 (-41.75072d) Equinox: J2000	Proper Motion RA: -0.015 sec of time/yr Proper Motion Dec: 0.223 arcsec/yr Parallax: 0.0" Epoch of Position: 2013 Radial Velocity: 0.0 km/sec	V=(?) Halpna surface brightness 5.3e-1 6 erg/s/cm2/arcsec	Reference Frame: ACS image j9c391919_drz																																																																																																																						
#	Name	Target Coordinates	Targ. Coord. Corrections	Fluxes	Miscellaneous																																																																																																																																							
(1)	SN1006-NW	RA: 15 02 16.1510 (225.5672958d) Dec: -41 45 2.60 (-41.75072d) Equinox: J2000	Proper Motion RA: -0.015 sec of time/yr Proper Motion Dec: 0.223 arcsec/yr Parallax: 0.0" Epoch of Position: 2013 Radial Velocity: 0.0 km/sec	V=(?) Halpna surface brightness 5.3e-1 6 erg/s/cm2/arcsec	Reference Frame: ACS image j9c391919_drz																																																																																																																																							
Exposures	<table border="1"> <thead> <tr> <th>#</th> <th>Label</th> <th>Target</th> <th>Config,Mode,Aperture</th> <th>Spectral Els.</th> <th>Opt. Params.</th> <th>Special Reqs.</th> <th>Groups</th> <th>Exp. Time/[Actual Dur.]</th> <th>Orbit</th> </tr> </thead> <tbody> <tr> <td>1</td> <td>(1)</td> <td>SN1006-NW</td> <td>ACS/WFC, ACCUM, WFC</td> <td>F658N POL0V</td> <td></td> <td>POS TARG 0.0,0.09 1</td> <td>Prime + Parallel Group 1-4 in Visit 03</td> <td>770 Secs [==>]</td> <td>[1]</td> </tr> <tr> <td>2</td> <td>(1)</td> <td>SN1006-NW</td> <td>ACS/WFC, ACCUM, WFC</td> <td>F658N POL60V</td> <td></td> <td>SAME POS AS 1</td> <td>Prime + Parallel Group 1-4 in Visit 03</td> <td>770 Secs [==>]</td> <td>[1]</td> </tr> <tr> <td>3</td> <td>(1)</td> <td>SN1006-NW</td> <td>ACS/WFC, ACCUM, WFC</td> <td>F658N POL120V</td> <td></td> <td>SAME POS AS 1</td> <td>Prime + Parallel Group 1-4 in Visit 03</td> <td>770 Secs [==>]</td> <td>[1]</td> </tr> <tr> <td>4</td> <td>ANY</td> <td>WFC3/UVIS, ACCUM, UVIS</td> <td></td> <td>F657N</td> <td>CR-SPLIT=2; FLASH=5</td> <td></td> <td>Prime + Parallel Group 1-4 in Visit 03</td> <td>2800 Secs [==>(Split 1)] [==>(Split 2)]</td> <td>[1]</td> </tr> <tr> <td>5</td> <td>(1)</td> <td>SN1006-NW</td> <td>ACS/WFC, ACCUM, WFC</td> <td>F658N POL0V</td> <td></td> <td>POS TARG -0.247,- 0.003</td> <td>Prime + Parallel Group 5-8 in Visit 03</td> <td>820 Secs [==>]</td> <td>[2]</td> </tr> <tr> <td>6</td> <td>(1)</td> <td>SN1006-NW</td> <td>ACS/WFC, ACCUM, WFC</td> <td>F658N POL60V</td> <td></td> <td>SAME POS AS 5</td> <td>Prime + Parallel Group 5-8 in Visit 03</td> <td>820 Secs [==>]</td> <td>[2]</td> </tr> <tr> <td>7</td> <td>(1)</td> <td>SN1006-NW</td> <td>ACS/WFC, ACCUM, WFC</td> <td>F658N POL120V</td> <td></td> <td>SAME POS AS 5</td> <td>Prime + Parallel Group 5-8 in Visit 03</td> <td>820 Secs [==>]</td> <td>[2]</td> </tr> <tr> <td>8</td> <td>ANY</td> <td>WFC3/UVIS, ACCUM, UVIS</td> <td></td> <td>F657N</td> <td>CR-SPLIT=2; FLASH=5</td> <td></td> <td>Prime + Parallel Group 5-8 in Visit 03</td> <td>2800 Secs [==>(Split 1)] [==>(Split 2)]</td> <td>[2]</td> </tr> <tr> <td>9</td> <td>(1)</td> <td>SN1006-NW</td> <td>ACS/WFC, ACCUM, WFC</td> <td>F658N POL0V</td> <td></td> <td>POS TARG 0.124,-0 .047</td> <td>Prime + Parallel Group 9-12 in Visit 03</td> <td>820 Secs [==>]</td> <td>[3]</td> </tr> <tr> <td>10</td> <td>(1)</td> <td>SN1006-NW</td> <td>ACS/WFC, ACCUM, WFC</td> <td>F658N POL60V</td> <td></td> <td>SAME POS AS 9</td> <td>Prime + Parallel Group 9-12 in Visit 03</td> <td>820 Secs [==>]</td> <td>[3]</td> </tr> <tr> <td>11</td> <td>(1)</td> <td>SN1006-NW</td> <td>ACS/WFC, ACCUM, WFC</td> <td>F658N POL120V</td> <td></td> <td>SAME POS AS 9</td> <td>Prime + Parallel Group 9-12 in Visit 03</td> <td>820 Secs [==>]</td> <td>[3]</td> </tr> <tr> <td>12</td> <td>ANY</td> <td>WFC3/UVIS, ACCUM, UVIS</td> <td></td> <td>F657N</td> <td>CR-SPLIT=2; FLASH=5</td> <td></td> <td>Prime + Parallel Group 9-12 in Visit 03</td> <td>2800 Secs [==>(Split 1)] [==>(Split 2)]</td> <td>[3]</td> </tr> </tbody> </table>										#	Label	Target	Config,Mode,Aperture	Spectral Els.	Opt. Params.	Special Reqs.	Groups	Exp. Time/[Actual Dur.]	Orbit	1	(1)	SN1006-NW	ACS/WFC, ACCUM, WFC	F658N POL0V		POS TARG 0.0,0.09 1	Prime + Parallel Group 1-4 in Visit 03	770 Secs [==>]	[1]	2	(1)	SN1006-NW	ACS/WFC, ACCUM, WFC	F658N POL60V		SAME POS AS 1	Prime + Parallel Group 1-4 in Visit 03	770 Secs [==>]	[1]	3	(1)	SN1006-NW	ACS/WFC, ACCUM, WFC	F658N POL120V		SAME POS AS 1	Prime + Parallel Group 1-4 in Visit 03	770 Secs [==>]	[1]	4	ANY	WFC3/UVIS, ACCUM, UVIS		F657N	CR-SPLIT=2; FLASH=5		Prime + Parallel Group 1-4 in Visit 03	2800 Secs [==>(Split 1)] [==>(Split 2)]	[1]	5	(1)	SN1006-NW	ACS/WFC, ACCUM, WFC	F658N POL0V		POS TARG -0.247,- 0.003	Prime + Parallel Group 5-8 in Visit 03	820 Secs [==>]	[2]	6	(1)	SN1006-NW	ACS/WFC, ACCUM, WFC	F658N POL60V		SAME POS AS 5	Prime + Parallel Group 5-8 in Visit 03	820 Secs [==>]	[2]	7	(1)	SN1006-NW	ACS/WFC, ACCUM, WFC	F658N POL120V		SAME POS AS 5	Prime + Parallel Group 5-8 in Visit 03	820 Secs [==>]	[2]	8	ANY	WFC3/UVIS, ACCUM, UVIS		F657N	CR-SPLIT=2; FLASH=5		Prime + Parallel Group 5-8 in Visit 03	2800 Secs [==>(Split 1)] [==>(Split 2)]	[2]	9	(1)	SN1006-NW	ACS/WFC, ACCUM, WFC	F658N POL0V		POS TARG 0.124,-0 .047	Prime + Parallel Group 9-12 in Visit 03	820 Secs [==>]	[3]	10	(1)	SN1006-NW	ACS/WFC, ACCUM, WFC	F658N POL60V		SAME POS AS 9	Prime + Parallel Group 9-12 in Visit 03	820 Secs [==>]	[3]	11	(1)	SN1006-NW	ACS/WFC, ACCUM, WFC	F658N POL120V		SAME POS AS 9	Prime + Parallel Group 9-12 in Visit 03	820 Secs [==>]	[3]	12	ANY	WFC3/UVIS, ACCUM, UVIS		F657N	CR-SPLIT=2; FLASH=5		Prime + Parallel Group 9-12 in Visit 03	2800 Secs [==>(Split 1)] [==>(Split 2)]	[3]
#	Label	Target	Config,Mode,Aperture	Spectral Els.	Opt. Params.	Special Reqs.	Groups	Exp. Time/[Actual Dur.]	Orbit																																																																																																																																			
1	(1)	SN1006-NW	ACS/WFC, ACCUM, WFC	F658N POL0V		POS TARG 0.0,0.09 1	Prime + Parallel Group 1-4 in Visit 03	770 Secs [==>]	[1]																																																																																																																																			
2	(1)	SN1006-NW	ACS/WFC, ACCUM, WFC	F658N POL60V		SAME POS AS 1	Prime + Parallel Group 1-4 in Visit 03	770 Secs [==>]	[1]																																																																																																																																			
3	(1)	SN1006-NW	ACS/WFC, ACCUM, WFC	F658N POL120V		SAME POS AS 1	Prime + Parallel Group 1-4 in Visit 03	770 Secs [==>]	[1]																																																																																																																																			
4	ANY	WFC3/UVIS, ACCUM, UVIS		F657N	CR-SPLIT=2; FLASH=5		Prime + Parallel Group 1-4 in Visit 03	2800 Secs [==>(Split 1)] [==>(Split 2)]	[1]																																																																																																																																			
5	(1)	SN1006-NW	ACS/WFC, ACCUM, WFC	F658N POL0V		POS TARG -0.247,- 0.003	Prime + Parallel Group 5-8 in Visit 03	820 Secs [==>]	[2]																																																																																																																																			
6	(1)	SN1006-NW	ACS/WFC, ACCUM, WFC	F658N POL60V		SAME POS AS 5	Prime + Parallel Group 5-8 in Visit 03	820 Secs [==>]	[2]																																																																																																																																			
7	(1)	SN1006-NW	ACS/WFC, ACCUM, WFC	F658N POL120V		SAME POS AS 5	Prime + Parallel Group 5-8 in Visit 03	820 Secs [==>]	[2]																																																																																																																																			
8	ANY	WFC3/UVIS, ACCUM, UVIS		F657N	CR-SPLIT=2; FLASH=5		Prime + Parallel Group 5-8 in Visit 03	2800 Secs [==>(Split 1)] [==>(Split 2)]	[2]																																																																																																																																			
9	(1)	SN1006-NW	ACS/WFC, ACCUM, WFC	F658N POL0V		POS TARG 0.124,-0 .047	Prime + Parallel Group 9-12 in Visit 03	820 Secs [==>]	[3]																																																																																																																																			
10	(1)	SN1006-NW	ACS/WFC, ACCUM, WFC	F658N POL60V		SAME POS AS 9	Prime + Parallel Group 9-12 in Visit 03	820 Secs [==>]	[3]																																																																																																																																			
11	(1)	SN1006-NW	ACS/WFC, ACCUM, WFC	F658N POL120V		SAME POS AS 9	Prime + Parallel Group 9-12 in Visit 03	820 Secs [==>]	[3]																																																																																																																																			
12	ANY	WFC3/UVIS, ACCUM, UVIS		F657N	CR-SPLIT=2; FLASH=5		Prime + Parallel Group 9-12 in Visit 03	2800 Secs [==>(Split 1)] [==>(Split 2)]	[3]																																																																																																																																			

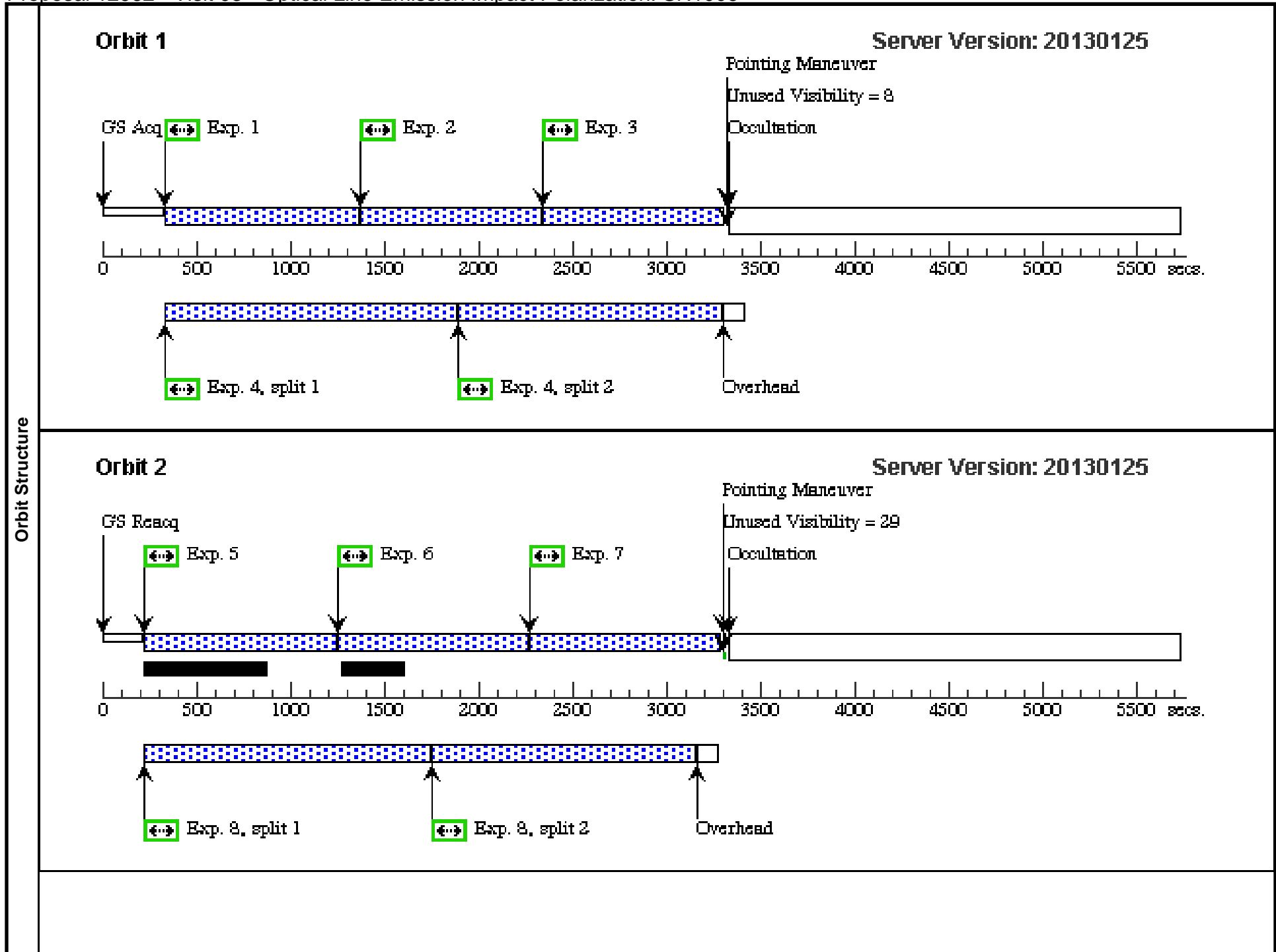

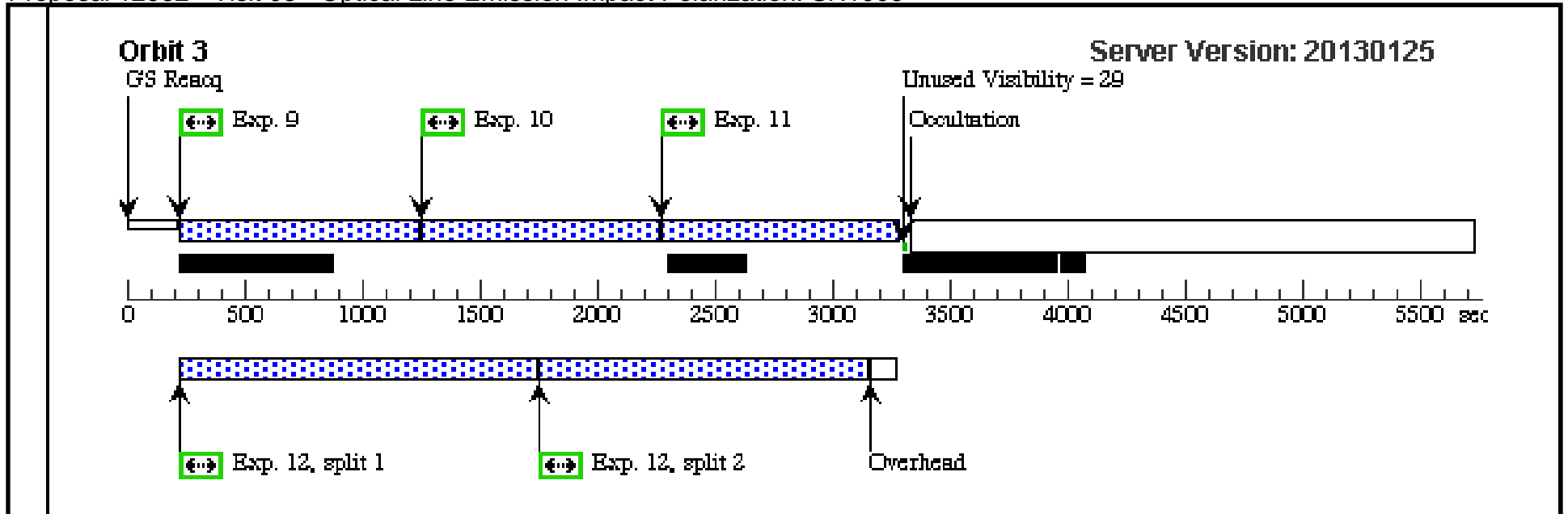

Proposal 12962 - Visit 04 - Optical Line Emission Impact Polarization: SN1006

Sat May 25 01:22:23 GMT 2013

Visit	Proposal 12962, Visit 04, failed Diagnostic Status: Warning Scientific Instruments: WFC3/IR, ACS/WFC Special Requirements: ORIENT 355D TO 5 D																																																																																																																																											
Diagnostics	(Visit 04) Warning (Orbit Planner): SAME POS MAY NOT BE APPROPRIATE (Visit 04) Warning (Orbit Planner): SAME POS MAY NOT BE APPROPRIATE (Visit 04) Warning (Orbit Planner): SAME POS MAY NOT BE APPROPRIATE (Visit 04) Warning (Orbit Planner): SAME POS MAY NOT BE APPROPRIATE (Visit 04) Warning (Orbit Planner): SAME POS MAY NOT BE APPROPRIATE (Visit 04) Warning (Orbit Planner): SAME POS MAY NOT BE APPROPRIATE																																																																																																																																											
Fixed Targets	<table border="1"> <thead> <tr> <th>#</th> <th>Name</th> <th>Target Coordinates</th> <th>Targ. Coord. Corrections</th> <th>Fluxes</th> <th>Miscellaneous</th> </tr> </thead> <tbody> <tr> <td>(1)</td> <td>SN1006-NW</td> <td>RA: 15 02 16.1510 (225.5672958d) Dec: -41 45 2.60 (-41.75072d) Equinox: J2000</td> <td>Proper Motion RA: -0.015 sec of time/yr Proper Motion Dec: 0.223 arcsec/yr Parallax: 0.0" Epoch of Position: 2013 Radial Velocity: 0.0 km/sec</td> <td>V=(?) Halpna surface brightness 5.3e-16 erg/s/cm2/arcsec</td> <td>Reference Frame: ACS image j9c391919_drz</td> </tr> </tbody> </table> <p><i>Comments: Proper motion for Region E of Winkler et al 2003 ApJ 585, 324.</i></p>										#	Name	Target Coordinates	Targ. Coord. Corrections	Fluxes	Miscellaneous	(1)	SN1006-NW	RA: 15 02 16.1510 (225.5672958d) Dec: -41 45 2.60 (-41.75072d) Equinox: J2000	Proper Motion RA: -0.015 sec of time/yr Proper Motion Dec: 0.223 arcsec/yr Parallax: 0.0" Epoch of Position: 2013 Radial Velocity: 0.0 km/sec	V=(?) Halpna surface brightness 5.3e-16 erg/s/cm2/arcsec	Reference Frame: ACS image j9c391919_drz																																																																																																																						
#	Name	Target Coordinates	Targ. Coord. Corrections	Fluxes	Miscellaneous																																																																																																																																							
(1)	SN1006-NW	RA: 15 02 16.1510 (225.5672958d) Dec: -41 45 2.60 (-41.75072d) Equinox: J2000	Proper Motion RA: -0.015 sec of time/yr Proper Motion Dec: 0.223 arcsec/yr Parallax: 0.0" Epoch of Position: 2013 Radial Velocity: 0.0 km/sec	V=(?) Halpna surface brightness 5.3e-16 erg/s/cm2/arcsec	Reference Frame: ACS image j9c391919_drz																																																																																																																																							
Exposures	<table border="1"> <thead> <tr> <th>#</th> <th>Label</th> <th>Target</th> <th>Config,Mode,Aperture</th> <th>Spectral Els.</th> <th>Opt. Params.</th> <th>Special Reqs.</th> <th>Groups</th> <th>Exp. Time/[Actual Dur.]</th> <th>Orbit</th> </tr> </thead> <tbody> <tr> <td>1</td> <td>(1) SN1006-NW</td> <td>ACS/WFC, ACCUM, WFC</td> <td>F658N POL0V</td> <td></td> <td></td> <td>POS TARG 0.371,0.047</td> <td>Prime + Parallel Group 1-4 in Visit 04</td> <td>765 Secs [==>]</td> <td>[1]</td> </tr> <tr> <td>2</td> <td>(1) SN1006-NW</td> <td>ACS/WFC, ACCUM, WFC</td> <td>F658N POL60V</td> <td></td> <td></td> <td>SAME POS AS 1</td> <td>Prime + Parallel Group 1-4 in Visit 04</td> <td>765 Secs [==>]</td> <td>[1]</td> </tr> <tr> <td>3</td> <td>(1) SN1006-NW</td> <td>ACS/WFC, ACCUM, WFC</td> <td>F658N POL120V</td> <td></td> <td></td> <td>SAME POS AS 1</td> <td>Prime + Parallel Group 1-4 in Visit 04</td> <td>765 Secs [==>]</td> <td>[1]</td> </tr> <tr> <td>4</td> <td>ANY</td> <td>WFC3/IR, MULTIACCUM, IR</td> <td>F128N</td> <td>SAMP-SEQ=SPARS 100; NSAMP=15</td> <td></td> <td></td> <td>Prime + Parallel Group 1-4 in Visit 04</td> <td>[==>(Copy 1)] [==>(Copy 2)]</td> <td>[1]</td> </tr> <tr> <td>5</td> <td>(1) SN1006-NW</td> <td>ACS/WFC, ACCUM, WFC</td> <td>F658N POL0V</td> <td></td> <td></td> <td>POS TARG 0.247,0.185</td> <td>Prime + Parallel Group 5-8 in Visit 04</td> <td>820 Secs [==>]</td> <td>[2]</td> </tr> <tr> <td>6</td> <td>(1) SN1006-NW</td> <td>ACS/WFC, ACCUM, WFC</td> <td>F658N POL60V</td> <td></td> <td></td> <td>SAME POS AS 5</td> <td>Prime + Parallel Group 5-8 in Visit 04</td> <td>820 Secs [==>]</td> <td>[2]</td> </tr> <tr> <td>7</td> <td>(1) SN1006-NW</td> <td>ACS/WFC, ACCUM, WFC</td> <td>F658N POL120V</td> <td></td> <td></td> <td>SAME POS AS 5</td> <td>Prime + Parallel Group 5-8 in Visit 04</td> <td>820 Secs [==>]</td> <td>[2]</td> </tr> <tr> <td>8</td> <td>ANY</td> <td>WFC3/IR, MULTIACCUM, IR</td> <td>F128N</td> <td>SAMP-SEQ=SPARS 100; NSAMP=15</td> <td></td> <td></td> <td>Prime + Parallel Group 5-8 in Visit 04</td> <td>[==>(Copy 1)] [==>(Copy 2)]</td> <td>[2]</td> </tr> <tr> <td>9</td> <td>(1) SN1006-NW</td> <td>ACS/WFC, ACCUM, WFC</td> <td>F658N POL0V</td> <td></td> <td></td> <td>POS TARG 0.0,0.091</td> <td>Prime + Parallel Group 9-12 in Visit 04</td> <td>820 Secs [==>]</td> <td>[3]</td> </tr> <tr> <td>10</td> <td>(1) SN1006-NW</td> <td>ACS/WFC, ACCUM, WFC</td> <td>F658N POL60V</td> <td></td> <td></td> <td>SAME POS AS 9</td> <td>Prime + Parallel Group 9-12 in Visit 04</td> <td>820 Secs [==>]</td> <td>[3]</td> </tr> <tr> <td>11</td> <td>(1) SN1006-NW</td> <td>ACS/WFC, ACCUM, WFC</td> <td>F658N POL120V</td> <td></td> <td></td> <td>SAME POS AS 9</td> <td>Prime + Parallel Group 9-12 in Visit 04</td> <td>820 Secs [==>]</td> <td>[3]</td> </tr> <tr> <td>12</td> <td>ANY</td> <td>WFC3/IR, MULTIACCUM, IR</td> <td>F128N</td> <td>SAMP-SEQ=SPARS 100; NSAMP=15</td> <td></td> <td></td> <td>Prime + Parallel Group 9-12 in Visit 04</td> <td>[==>(Copy 1)] [==>(Copy 2)]</td> <td>[3]</td> </tr> </tbody> </table>										#	Label	Target	Config,Mode,Aperture	Spectral Els.	Opt. Params.	Special Reqs.	Groups	Exp. Time/[Actual Dur.]	Orbit	1	(1) SN1006-NW	ACS/WFC, ACCUM, WFC	F658N POL0V			POS TARG 0.371,0.047	Prime + Parallel Group 1-4 in Visit 04	765 Secs [==>]	[1]	2	(1) SN1006-NW	ACS/WFC, ACCUM, WFC	F658N POL60V			SAME POS AS 1	Prime + Parallel Group 1-4 in Visit 04	765 Secs [==>]	[1]	3	(1) SN1006-NW	ACS/WFC, ACCUM, WFC	F658N POL120V			SAME POS AS 1	Prime + Parallel Group 1-4 in Visit 04	765 Secs [==>]	[1]	4	ANY	WFC3/IR, MULTIACCUM, IR	F128N	SAMP-SEQ=SPARS 100; NSAMP=15			Prime + Parallel Group 1-4 in Visit 04	[==>(Copy 1)] [==>(Copy 2)]	[1]	5	(1) SN1006-NW	ACS/WFC, ACCUM, WFC	F658N POL0V			POS TARG 0.247,0.185	Prime + Parallel Group 5-8 in Visit 04	820 Secs [==>]	[2]	6	(1) SN1006-NW	ACS/WFC, ACCUM, WFC	F658N POL60V			SAME POS AS 5	Prime + Parallel Group 5-8 in Visit 04	820 Secs [==>]	[2]	7	(1) SN1006-NW	ACS/WFC, ACCUM, WFC	F658N POL120V			SAME POS AS 5	Prime + Parallel Group 5-8 in Visit 04	820 Secs [==>]	[2]	8	ANY	WFC3/IR, MULTIACCUM, IR	F128N	SAMP-SEQ=SPARS 100; NSAMP=15			Prime + Parallel Group 5-8 in Visit 04	[==>(Copy 1)] [==>(Copy 2)]	[2]	9	(1) SN1006-NW	ACS/WFC, ACCUM, WFC	F658N POL0V			POS TARG 0.0,0.091	Prime + Parallel Group 9-12 in Visit 04	820 Secs [==>]	[3]	10	(1) SN1006-NW	ACS/WFC, ACCUM, WFC	F658N POL60V			SAME POS AS 9	Prime + Parallel Group 9-12 in Visit 04	820 Secs [==>]	[3]	11	(1) SN1006-NW	ACS/WFC, ACCUM, WFC	F658N POL120V			SAME POS AS 9	Prime + Parallel Group 9-12 in Visit 04	820 Secs [==>]	[3]	12	ANY	WFC3/IR, MULTIACCUM, IR	F128N	SAMP-SEQ=SPARS 100; NSAMP=15			Prime + Parallel Group 9-12 in Visit 04	[==>(Copy 1)] [==>(Copy 2)]	[3]
#	Label	Target	Config,Mode,Aperture	Spectral Els.	Opt. Params.	Special Reqs.	Groups	Exp. Time/[Actual Dur.]	Orbit																																																																																																																																			
1	(1) SN1006-NW	ACS/WFC, ACCUM, WFC	F658N POL0V			POS TARG 0.371,0.047	Prime + Parallel Group 1-4 in Visit 04	765 Secs [==>]	[1]																																																																																																																																			
2	(1) SN1006-NW	ACS/WFC, ACCUM, WFC	F658N POL60V			SAME POS AS 1	Prime + Parallel Group 1-4 in Visit 04	765 Secs [==>]	[1]																																																																																																																																			
3	(1) SN1006-NW	ACS/WFC, ACCUM, WFC	F658N POL120V			SAME POS AS 1	Prime + Parallel Group 1-4 in Visit 04	765 Secs [==>]	[1]																																																																																																																																			
4	ANY	WFC3/IR, MULTIACCUM, IR	F128N	SAMP-SEQ=SPARS 100; NSAMP=15			Prime + Parallel Group 1-4 in Visit 04	[==>(Copy 1)] [==>(Copy 2)]	[1]																																																																																																																																			
5	(1) SN1006-NW	ACS/WFC, ACCUM, WFC	F658N POL0V			POS TARG 0.247,0.185	Prime + Parallel Group 5-8 in Visit 04	820 Secs [==>]	[2]																																																																																																																																			
6	(1) SN1006-NW	ACS/WFC, ACCUM, WFC	F658N POL60V			SAME POS AS 5	Prime + Parallel Group 5-8 in Visit 04	820 Secs [==>]	[2]																																																																																																																																			
7	(1) SN1006-NW	ACS/WFC, ACCUM, WFC	F658N POL120V			SAME POS AS 5	Prime + Parallel Group 5-8 in Visit 04	820 Secs [==>]	[2]																																																																																																																																			
8	ANY	WFC3/IR, MULTIACCUM, IR	F128N	SAMP-SEQ=SPARS 100; NSAMP=15			Prime + Parallel Group 5-8 in Visit 04	[==>(Copy 1)] [==>(Copy 2)]	[2]																																																																																																																																			
9	(1) SN1006-NW	ACS/WFC, ACCUM, WFC	F658N POL0V			POS TARG 0.0,0.091	Prime + Parallel Group 9-12 in Visit 04	820 Secs [==>]	[3]																																																																																																																																			
10	(1) SN1006-NW	ACS/WFC, ACCUM, WFC	F658N POL60V			SAME POS AS 9	Prime + Parallel Group 9-12 in Visit 04	820 Secs [==>]	[3]																																																																																																																																			
11	(1) SN1006-NW	ACS/WFC, ACCUM, WFC	F658N POL120V			SAME POS AS 9	Prime + Parallel Group 9-12 in Visit 04	820 Secs [==>]	[3]																																																																																																																																			
12	ANY	WFC3/IR, MULTIACCUM, IR	F128N	SAMP-SEQ=SPARS 100; NSAMP=15			Prime + Parallel Group 9-12 in Visit 04	[==>(Copy 1)] [==>(Copy 2)]	[3]																																																																																																																																			

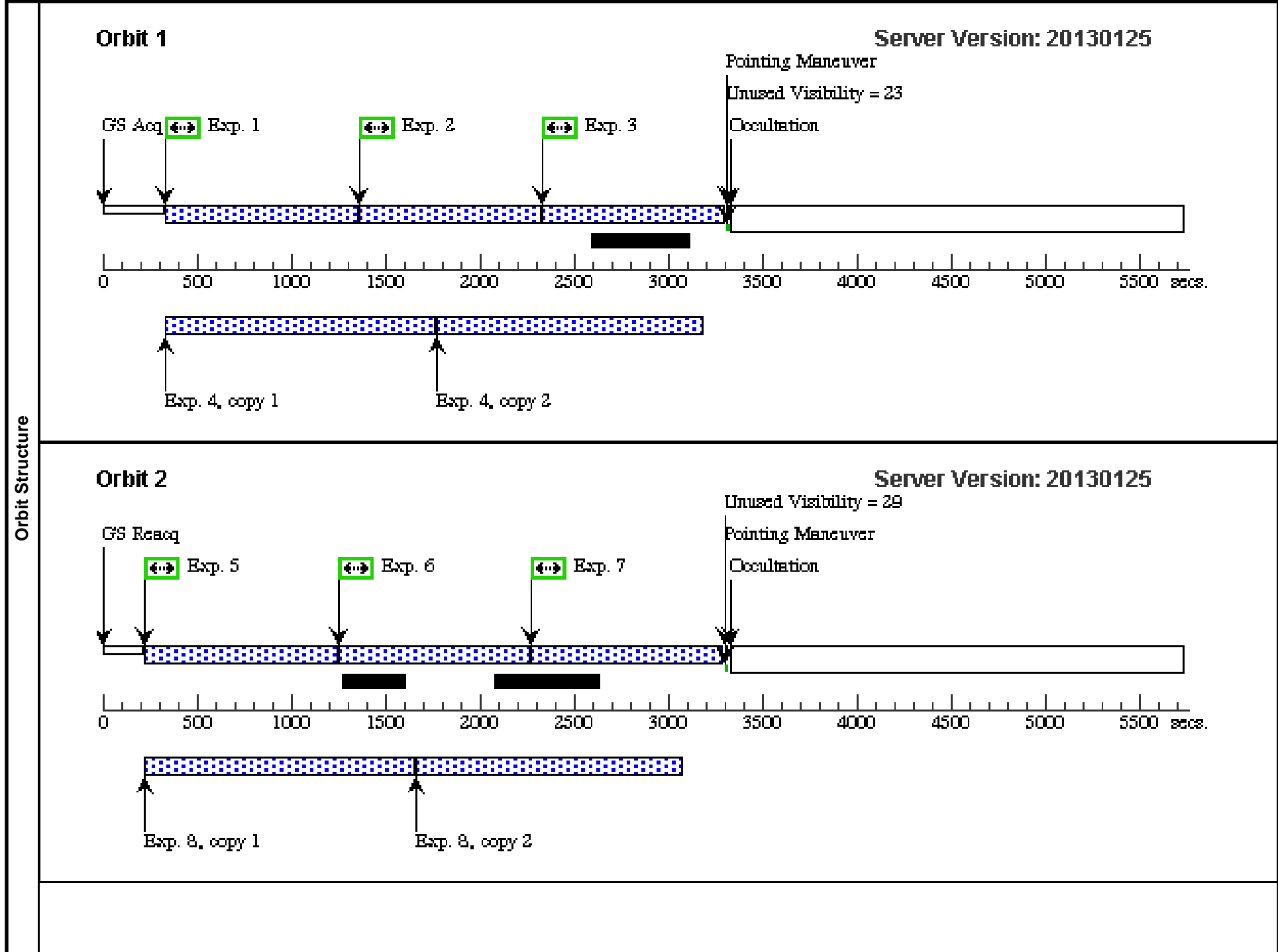

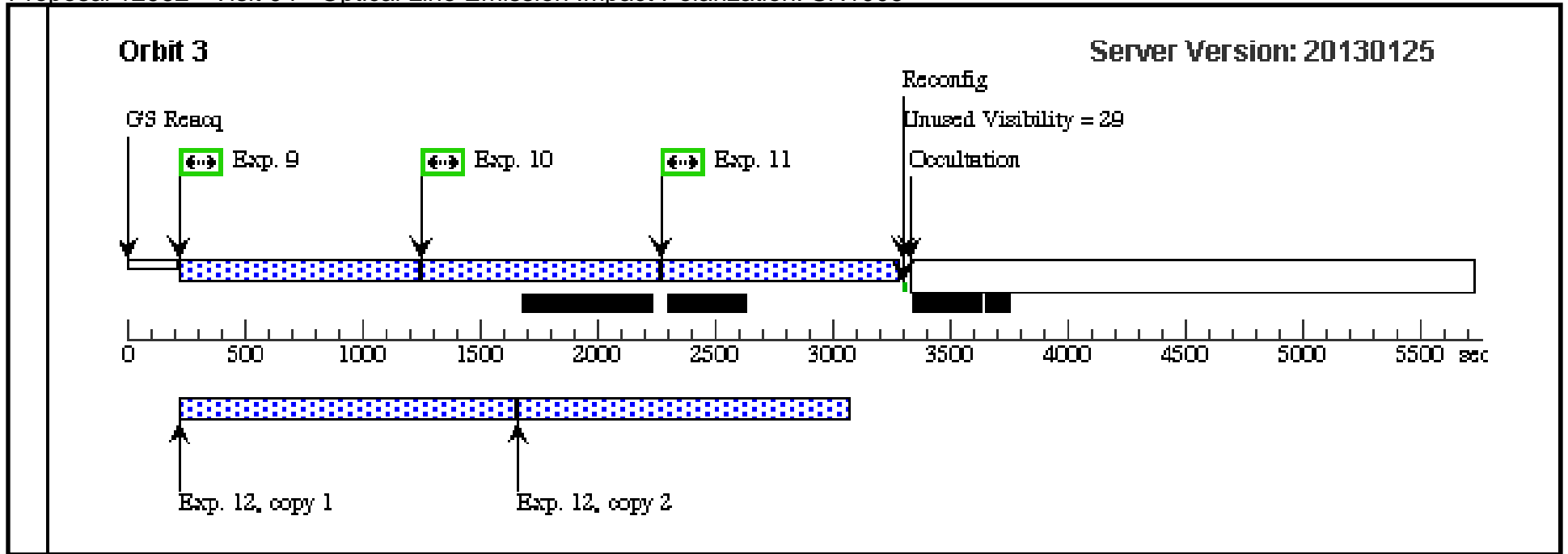

Proposal 12962 - Visit 54 - Optical Line Emission Impact Polarization: SN1006

Sat May 25 01:22:26 GMT 2013

Visit	Proposal 12962, Visit 54, implementation Diagnostic Status: Warning Scientific Instruments: WFC3/IR, ACS/WFC Special Requirements: (none) <i>Comments: Repeat of visit 04 which failed due to guide stars.</i>									
	(Visit 54) Warning (Orbit Planner): SAME POS MAY NOT BE APPROPRIATE (Visit 54) Warning (Orbit Planner): SAME POS MAY NOT BE APPROPRIATE (Visit 54) Warning (Orbit Planner): SAME POS MAY NOT BE APPROPRIATE (Visit 54) Warning (Orbit Planner): SAME POS MAY NOT BE APPROPRIATE (Visit 54) Warning (Orbit Planner): SAME POS MAY NOT BE APPROPRIATE (Visit 54) Warning (Orbit Planner): SAME POS MAY NOT BE APPROPRIATE									
Diagnosics										
Fixed Targets	#	Name	Target Coordinates	Targ. Coord. Corrections		Fluxes	Miscellaneous			
	(1)	SN1006-NW	RA: 15 02 16.1510 (225.5672958d) Dec: -41 45 2.60 (-41.75072d) Equinox: J2000	Proper Motion RA: -0.015 sec of time/yr Proper Motion Dec: 0.223 arcsec/yr Parallax: 0.0" Epoch of Position: 2013 Radial Velocity: 0.0 km/sec	V=(?) Halpna surface brightness 5.3e-16 erg/s/cm2/arcsec	Reference Frame: ACS image j9c391919_drz				
<i>Comments: Proper motion for Region E of Winkler et al 2003 ApJ 585, 324.</i>										
Exposures	#	Label	Target	Config,Mode,Aperture	Spectral Els.	Opt. Params.	Special Reqs.	Groups	Exp. Time/[Actual Dur.]	Orbit
	1		(1) SN1006-NW	ACS/WFC, ACCUM, WFC	F658N POL0V		POS TARG 0.371,0.047	Prime + Parallel Group 1-4 in Visit 54	765 Secs [==>]	[1]
	2		(1) SN1006-NW	ACS/WFC, ACCUM, WFC	F658N POL60V		SAME POS AS 1	Prime + Parallel Group 1-4 in Visit 54	765 Secs [==>]	[1]
	3		(1) SN1006-NW	ACS/WFC, ACCUM, WFC	F658N POL120V		SAME POS AS 1	Prime + Parallel Group 1-4 in Visit 54	765 Secs [==>]	[1]
	4		ANY	WFC3/IR, MULTIACCUM, IR	F128N	SAMP-SEQ=SPARS 100; NSAMP=15		Prime + Parallel Group 1-4 in Visit 54	[==>(Copy 1)] [==>(Copy 2)]	[1]
	5		(1) SN1006-NW	ACS/WFC, ACCUM, WFC	F658N POL0V		POS TARG 0.247,0.185	Prime + Parallel Group 5-8 in Visit 54	820 Secs [==>]	[2]
	6		(1) SN1006-NW	ACS/WFC, ACCUM, WFC	F658N POL60V		SAME POS AS 5	Prime + Parallel Group 5-8 in Visit 54	820 Secs [==>]	[2]
	7		(1) SN1006-NW	ACS/WFC, ACCUM, WFC	F658N POL120V		SAME POS AS 5	Prime + Parallel Group 5-8 in Visit 54	820 Secs [==>]	[2]
	8		ANY	WFC3/IR, MULTIACCUM, IR	F128N	SAMP-SEQ=SPARS 100; NSAMP=15		Prime + Parallel Group 5-8 in Visit 54	[==>(Copy 1)] [==>(Copy 2)]	[2]
	9		(1) SN1006-NW	ACS/WFC, ACCUM, WFC	F658N POL0V		POS TARG 0.0,0.091	Prime + Parallel Group 9-12 in Visit 54	820 Secs [==>]	[3]
	10		(1) SN1006-NW	ACS/WFC, ACCUM, WFC	F658N POL60V		SAME POS AS 9	Prime + Parallel Group 9-12 in Visit 54	820 Secs [==>]	[3]
	11		(1) SN1006-NW	ACS/WFC, ACCUM, WFC	F658N POL120V		SAME POS AS 9	Prime + Parallel Group 9-12 in Visit 54	820 Secs [==>]	[3]
12		ANY	WFC3/IR, MULTIACCUM, IR	F128N	SAMP-SEQ=SPARS 100; NSAMP=15		Prime + Parallel Group 9-12 in Visit 54	[==>(Copy 1)] [==>(Copy 2)]	[3]	

