



# 12971 - Completing the Empirical White Dwarf Cooling Sequence: Hot White Dwarfs in 47 Tucanae

Cycle: 20, Proposal Category: GO  
(Availability Mode: SUPPORTED)

## INVESTIGATORS

<i>Name</i>	<i>Institution</i>	<i>E-Mail</i>
<b>Dr. Harvey B. Richer (PI) (Contact)</b>	<b>University of British Columbia</b>	<b>richer@astro.ubc.ca</b>
Dr. Aaron Dotter (CoI)	Space Telescope Science Institute	dotter@stsci.edu
Mr. Ryan Goldsbury (CoI)	University of British Columbia	rgoldsb@phas.ubc.ca
Dr. Brad M. Hansen (CoI) (AdminUSPI)	University of California - Los Angeles	hansen@astro.ucla.edu
Dr. Jeremy Heyl (CoI)	University of British Columbia	hey1@phas.ubc.ca
Dr. Jason S. Kalirai (CoI)	Space Telescope Science Institute	jkalirai@stsci.edu
Dr. Kristin A. Woodley (CoI)	University of British Columbia	kwoodley@phas.ubc.ca
Dr. Kris Sigurdson (CoI)	University of British Columbia	krs@phas.ubc.ca

## VISITS

<i>Visit</i>	<i>Targets used in Visit</i>	<i>Configurations used in Visit</i>	<i>Orbits Used</i>	<i>Last Orbit Planner Run</i>	<i>OP Current with Visit?</i>
01	(1) 47TUC-FIELD1	ACS/WFC WFC3/UVIS	1	06-Aug-2012 21:53:57.0	yes
02	(2) 47TUC-FIELD2	ACS/WFC WFC3/UVIS	1	06-Aug-2012 21:54:09.0	yes
03	(3) 47TUC-FIELD3	ACS/WFC WFC3/UVIS	1	06-Aug-2012 21:54:19.0	yes

<i>Visit</i>	<i>Targets used in Visit</i>	<i>Configurations used in Visit</i>	<i>Orbits Used</i>	<i>Last Orbit Planner Run</i>	<i>OP Current with Visit?</i>
04	(4) 47TUC-FIELD4	ACS/WFC WFC3/UVIS	1	06-Aug-2012 21:54:29.0	yes
05	(5) 47TUC-FIELD5	ACS/WFC WFC3/UVIS	1	06-Aug-2012 21:54:38.0	yes
06	(6) 47TUC-FIELD6	ACS/WFC WFC3/UVIS	1	06-Aug-2012 21:54:46.0	yes
07	(7) 47TUC-FIELD7	ACS/WFC WFC3/UVIS	1	06-Aug-2012 21:54:55.0	yes
08	(8) 47TUC-FIELD8	ACS/WFC WFC3/UVIS	1	06-Aug-2012 21:55:04.0	yes
09	(9) 47TUC-FIELD9	ACS/WFC WFC3/UVIS	1	06-Aug-2012 21:55:13.0	yes
10	(10) 47TUC-FIELD10	ACS/WFC WFC3/UVIS	1	06-Aug-2012 21:55:21.0	yes

10 Total Orbits Used

### **ABSTRACT**

In HST Cycle 17 we obtained panchromatic imaging data in 47 Tuc covering the UV through to the IR over 60 square arcmins in 14 different fields. From the UV data obtained with WFC3 we were able to construct an empirical white dwarf cooling sequence and compare it with various theoretical models. The data exhibited a sharp break in slope at  $\sim 20,000\text{K}$ . Cooler than this it followed the expected Mestel slope of  $-0.4$  in Log Temperature vs Log Age and above this temperature the slope was somewhat more gentle ( $-0.2$ ). The number of white dwarfs detected with temperatures above  $30,000\text{K}$  (only 10) was too small to constrain the slope of the cooling sequence at the very hot end. This is because hot white dwarfs cool quite quickly and are thus rare objects. This segment of the cooling sequence is of great interest as white dwarfs are expected to cool mainly by neutrino emission at these hot temperatures. An empirical cooling sequence extending well into this region containing  $\sim 100$  white dwarfs above  $30,000\text{K}$ , will allow us to test several predictions of neutrino physics and possibly provide a hint whether axions are produced in processes similar to those that manufacture neutrinos.

## **OBSERVING DESCRIPTION**

Our observing plan allows us to observe with both WFC3/UVIS and ACS/WFC simultaneously.

In order to reach our required depth to include hot WDs greater than 30,000K, we will observe for a total of 1040sec in F225W, followed by 1130sec in F336W with 2 exposures in each filter. This will be similarly done with F475W (981sec) and F555W (982sec) with ACS. The individual exposure times are long enough to allow the buffer to be dumped in parallel to our subsequent exposure. Obtaining just 2 exposures in each filter will not compromise the data as our parallel

exposures with WFC3/UVIS from our Cycle 17 project also only included two exposures in each of the two UVIS filters. With these exposure times, we will be able to reach a  $S/N > 100$  for 30,000K WDs in 47 Tuc,  $E(B-V)=0.04$ , and using a standard HST star spectra of GD71 (32,300K DA WD). In total we observe 10 fields with each camera, 1 orbit each, for a total request of 10 orbits.

Our time estimates in WFC3 include a 6 minute guide star acquisition for each orbit, image overheads of 2.6 minutes for the first exposure and 2.1 minutes for the second exposure in F225W and F336W. In ACS, our time estimates include a 6 minute guide star acquisition, image overheads of 4 minutes for the first exposure and 2.5 minutes for the second exposure in F475W and F555W. Our total observing times are 40.4 minutes in WFC3 and 44 minutes in ACS. Both of these times are well below the reduced visibility of 51 minutes per orbit in Cycle 20 due to our target's right ascension.

Proposal 12971 - Field 1 (01) - Completing the Empirical White Dwarf Cooling Sequence: Hot White Dwarfs in 47 Tucanae

Tue Aug 07 01:55:30 GMT 2012

Visit	<b>Proposal 12971, Field 1 (01), implementation</b> <b>Diagnostic Status: No Diagnostics</b> Scientific Instruments: WFC3/UVIS, ACS/WFC Special Requirements: SCHED 100%; ORIENT 46.D TO 46. D									
	Fixed Targets	#	Name	Target Coordinates	Targ. Coord. Corrections	Fluxes	Miscellaneous			
	(1)	47TUC-FIELD1	RA: 00 24 19.7304 (6.0822100d) Dec: -72 05 39.66 (-72.09435d) Equinox: J2000		V=3.95	Reference Frame: ICRS				
Exposures	#	Label	Target	Config,Mode,Aperture	Spectral Els.	Opt. Params.	Special Reqs.	Groups	Exp. Time/[Actual Dur.]	Orbit
	1	(1) 47TUC-FIELD1		WFC3/UVIS, ACCUM, UVIS	F225W		POS TARG 0,null	Prime + Parallel Group 1-2 in Field 1 (01)	380 Secs [==>]	[1]
	2	(1) 47TUC-FIELD1		ACS/WFC, ACCUM, WFC	F435W			Prime + Parallel Group 1-2 in Field 1 (01)	290 Secs [==>]	[1]
	3	(1) 47TUC-FIELD1		WFC3/UVIS, ACCUM, UVIS	F225W		POS TARG 5,5	Prime + Parallel Group 3-4 in Field 1 (01)	700 Secs [==>]	[1]
	4	(1) 47TUC-FIELD1		ACS/WFC, ACCUM, WFC	F435W			Prime + Parallel Group 3-4 in Field 1 (01)	690 Secs [==>]	[1]
	5	(1) 47TUC-FIELD1		WFC3/UVIS, ACCUM, UVIS	F336W		POS TARG 5,5	Prime + Parallel Group 5-6 in Field 1 (01)	720 Secs [==>]	[1]
	6	(1) 47TUC-FIELD1		ACS/WFC, ACCUM, WFC	F555W			Prime + Parallel Group 5-6 in Field 1 (01)	660 Secs [==>]	[1]
	7	(1) 47TUC-FIELD1		WFC3/UVIS, ACCUM, UVIS	F336W		POS TARG 0,0	Prime + Parallel Group 7-8 in Field 1 (01)	485 Secs [==>]	[1]
	8	(1) 47TUC-FIELD1		ACS/WFC, ACCUM, WFC	F555W			Prime + Parallel Group 7-8 in Field 1 (01)	360 Secs [==>]	[1]

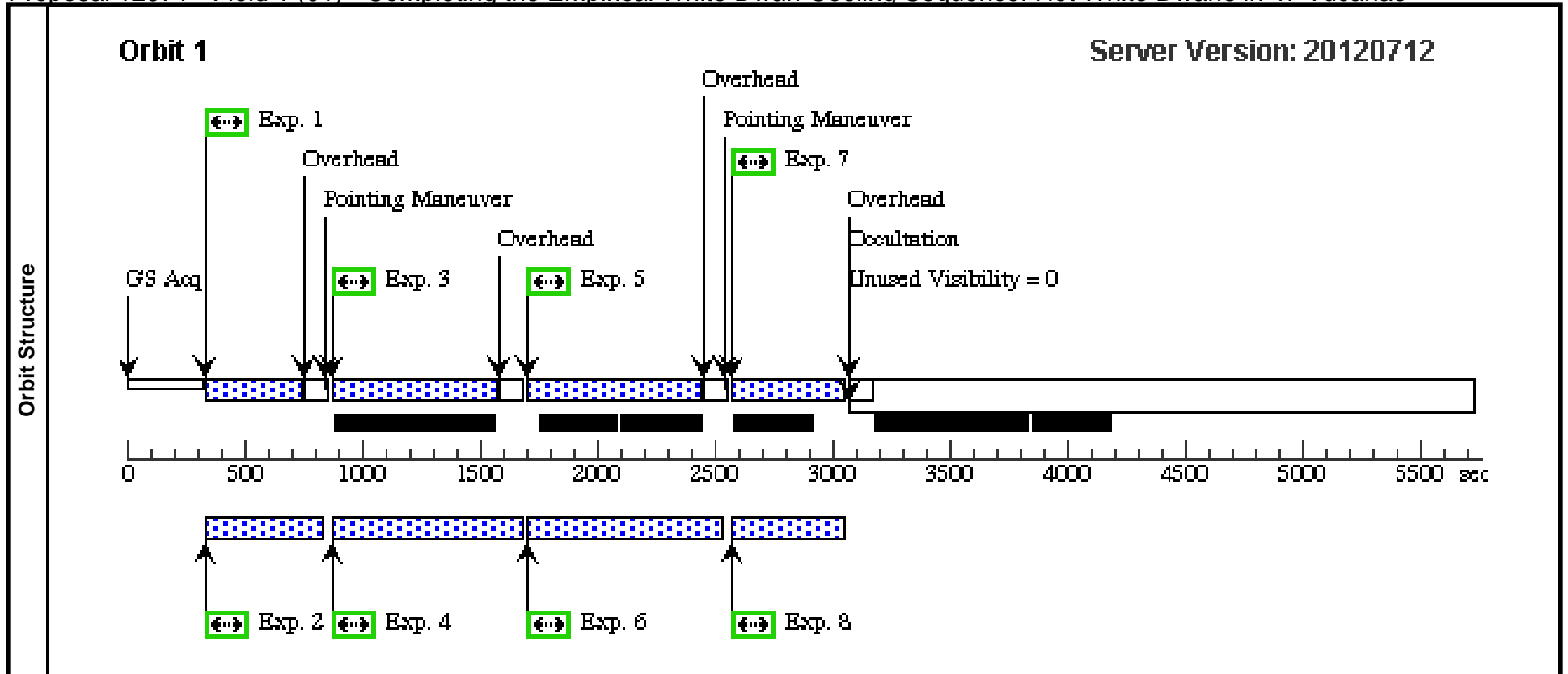

Proposal 12971 - Field 2 (02) - Completing the Empirical White Dwarf Cooling Sequence: Hot White Dwarfs in 47 Tucanae

Tue Aug 07 01:55:32 GMT 2012

Visit	<b>Proposal 12971, Field 2 (02), implementation</b> <b>Diagnostic Status: No Diagnostics</b> Scientific Instruments: WFC3/UVIS, ACS/WFC Special Requirements: SCHED 100%; ORIENT 82.D TO 82. D									
	Fixed Targets	#	Name	Target Coordinates	Targ. Coord. Corrections	Fluxes	Miscellaneous			
	(2)	47TUC-FIELD2	RA: 00 24 11.0616 (6.0460900d) Dec: -72 06 8.71 (-72.10242d) Equinox: J2000		V=3.95	Reference Frame: ICRS				
Exposures	#	Label	Target	Config,Mode,Aperture	Spectral Els.	Opt. Params.	Special Reqs.	Groups	Exp. Time/[Actual Dur.]	Orbit
	1	(2) 47TUC-FIELD2		WFC3/UVIS, ACCUM, UVIS	F225W		POS TARG 0,null	Prime + Parallel Group 1-2 in Field 2 (02)	380 Secs [==>]	[1]
	2	(2) 47TUC-FIELD2		ACS/WFC, ACCUM, WFC	F435W			Prime + Parallel Group 1-2 in Field 2 (02)	290 Secs [==>]	[1]
	3	(2) 47TUC-FIELD2		WFC3/UVIS, ACCUM, UVIS	F225W		POS TARG 5,5	Prime + Parallel Group 3-4 in Field 2 (02)	700 Secs [==>]	[1]
	4	(2) 47TUC-FIELD2		ACS/WFC, ACCUM, WFC	F435W			Prime + Parallel Group 3-4 in Field 2 (02)	690 Secs [==>]	[1]
	5	(2) 47TUC-FIELD2		WFC3/UVIS, ACCUM, UVIS	F336W		POS TARG 5,5	Prime + Parallel Group 5-6 in Field 2 (02)	720 Secs [==>]	[1]
	6	(2) 47TUC-FIELD2		ACS/WFC, ACCUM, WFC	F555W			Prime + Parallel Group 5-6 in Field 2 (02)	660 Secs [==>]	[1]
	7	(2) 47TUC-FIELD2		WFC3/UVIS, ACCUM, UVIS	F336W		POS TARG 0,0	Prime + Parallel Group 7-8 in Field 2 (02)	485 Secs [==>]	[1]
	8	(2) 47TUC-FIELD2		ACS/WFC, ACCUM, WFC	F555W			Prime + Parallel Group 7-8 in Field 2 (02)	360 Secs [==>]	[1]

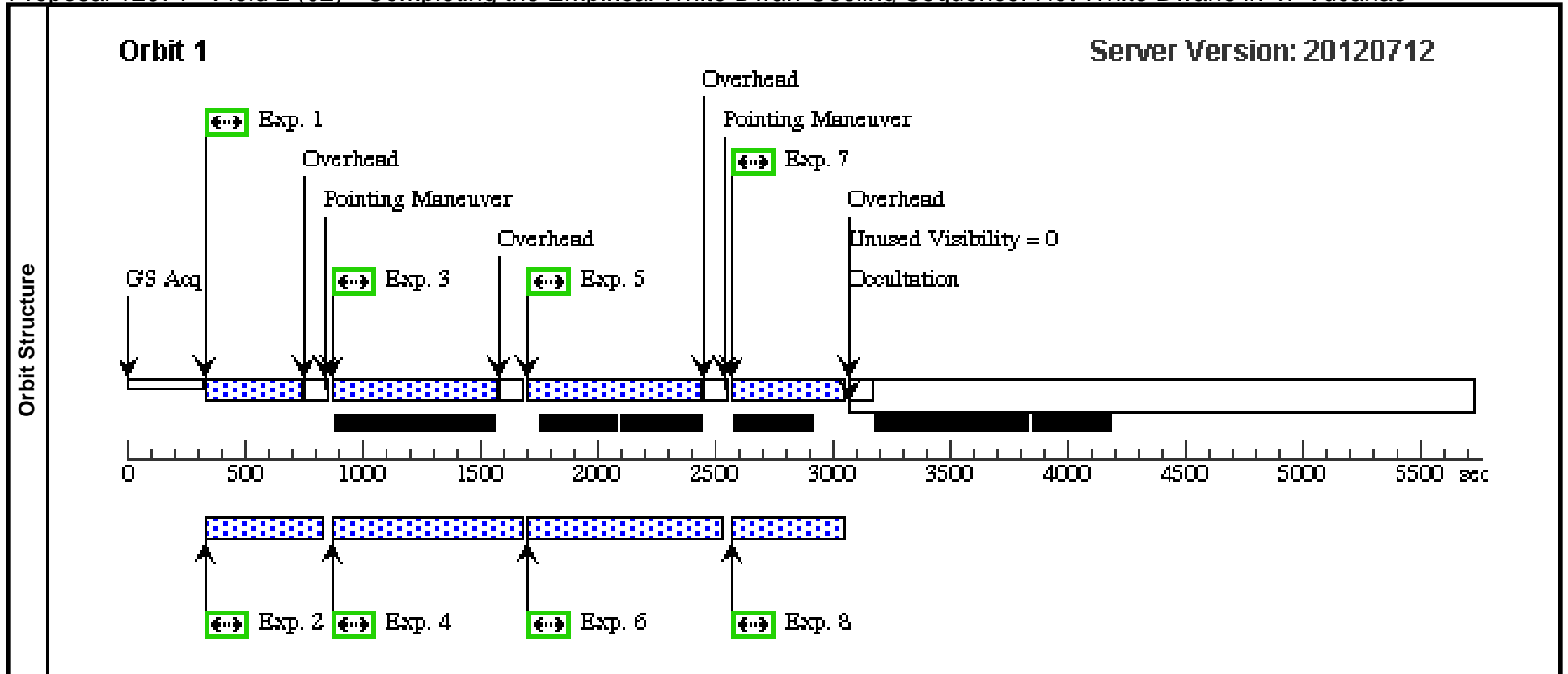

Proposal 12971 - Field 3 (03) - Completing the Empirical White Dwarf Cooling Sequence: Hot White Dwarfs in 47 Tucanae

Tue Aug 07 01:55:33 GMT 2012

Visit	<b>Proposal 12971, Field 3 (03), implementation</b> <b>Diagnostic Status: No Diagnostics</b> Scientific Instruments: WFC3/UVIS, ACS/WFC Special Requirements: SCHED 100%; ORIENT 118.D TO 118. D									
	Fixed Targets	#	Name	Target Coordinates	Targ. Coord. Corrections	Fluxes	Miscellaneous			
	(3)	47TUC-FIELD3	RA: 00 24 0.3504 (6.0014600d) Dec: -72 06 8.71 (-72.10242d) Equinox: J2000		V=3.95	Reference Frame: ICRS				
Exposures	#	Label	Target	Config,Mode,Aperture	Spectral Els.	Opt. Params.	Special Reqs.	Groups	Exp. Time/[Actual Dur.]	Orbit
	1	(3) 47TUC-FIELD3		WFC3/UVIS, ACCUM, UVIS	F225W		POS TARG 0,null	Prime + Parallel Group 1-2 in Field 3 (03)	380 Secs [==>]	[1]
	2	(3) 47TUC-FIELD3		ACS/WFC, ACCUM, WFC	F435W			Prime + Parallel Group 1-2 in Field 3 (03)	290 Secs [==>]	[1]
	3	(3) 47TUC-FIELD3		WFC3/UVIS, ACCUM, UVIS	F225W		POS TARG 5,5	Prime + Parallel Group 3-4 in Field 3 (03)	700 Secs [==>]	[1]
	4	(3) 47TUC-FIELD3		ACS/WFC, ACCUM, WFC	F435W			Prime + Parallel Group 3-4 in Field 3 (03)	690 Secs [==>]	[1]
	5	(3) 47TUC-FIELD3		WFC3/UVIS, ACCUM, UVIS	F336W		POS TARG 5,5	Prime + Parallel Group 5-6 in Field 3 (03)	720 Secs [==>]	[1]
	6	(3) 47TUC-FIELD3		ACS/WFC, ACCUM, WFC	F555W			Prime + Parallel Group 5-6 in Field 3 (03)	660 Secs [==>]	[1]
	7	(3) 47TUC-FIELD3		WFC3/UVIS, ACCUM, UVIS	F336W		POS TARG 0,0	Prime + Parallel Group 7-8 in Field 3 (03)	485 Secs [==>]	[1]
	8	(3) 47TUC-FIELD3		ACS/WFC, ACCUM, WFC	F555W			Prime + Parallel Group 7-8 in Field 3 (03)	360 Secs [==>]	[1]

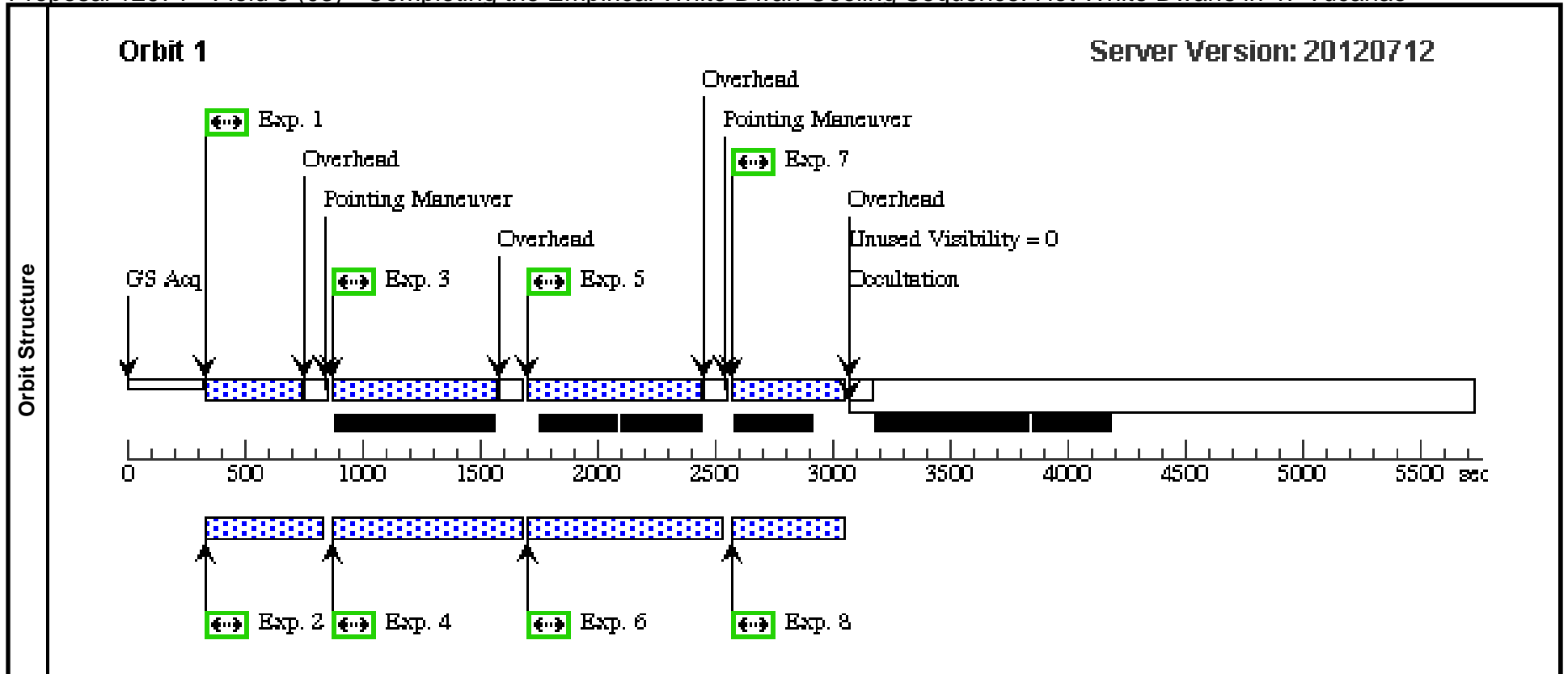

Proposal 12971 - Field 4 (04) - Completing the Empirical White Dwarf Cooling Sequence: Hot White Dwarfs in 47 Tucanae

Tue Aug 07 01:55:34 GMT 2012

Visit	<b>Proposal 12971, Field 4 (04), implementation</b> <b>Diagnostic Status: No Diagnostics</b> Scientific Instruments: WFC3/UVIS, ACS/WFC Special Requirements: SCHED 100%; ORIENT 154.D TO 154. D									
	Fixed Targets	#	Name	Target Coordinates	Targ. Coord. Corrections	Fluxes	Miscellaneous			
	(4)	47TUC-FIELD4	RA: 00 23 51.6816 (5.9653400d) Dec: -72 05 39.66 (-72.09435d) Equinox: J2000		V=3.95	Reference Frame: ICRS				
Exposures	#	Label	Target	Config,Mode,Aperture	Spectral Els.	Opt. Params.	Special Reqs.	Groups	Exp. Time/[Actual Dur.]	Orbit
	1	(4) 47TUC-FIELD4		WFC3/UVIS, ACCUM, UVIS	F225W		POS TARG 0,null	Prime + Parallel Group 1-2 in Field 4 (04)	380 Secs [==>]	[1]
	2	(4) 47TUC-FIELD4		ACS/WFC, ACCUM, WFC	F435W			Prime + Parallel Group 1-2 in Field 4 (04)	290 Secs [==>]	[1]
	3	(4) 47TUC-FIELD4		WFC3/UVIS, ACCUM, UVIS	F225W		POS TARG 5,5	Prime + Parallel Group 3-4 in Field 4 (04)	700 Secs [==>]	[1]
	4	(4) 47TUC-FIELD4		ACS/WFC, ACCUM, WFC	F435W			Prime + Parallel Group 3-4 in Field 4 (04)	690 Secs [==>]	[1]
	5	(4) 47TUC-FIELD4		WFC3/UVIS, ACCUM, UVIS	F336W		POS TARG 5,5	Prime + Parallel Group 5-6 in Field 4 (04)	720 Secs [==>]	[1]
	6	(4) 47TUC-FIELD4		ACS/WFC, ACCUM, WFC	F555W			Prime + Parallel Group 5-6 in Field 4 (04)	660 Secs [==>]	[1]
	7	(4) 47TUC-FIELD4		WFC3/UVIS, ACCUM, UVIS	F336W		POS TARG 0,0	Prime + Parallel Group 7-8 in Field 4 (04)	485 Secs [==>]	[1]
	8	(4) 47TUC-FIELD4		ACS/WFC, ACCUM, WFC	F555W			Prime + Parallel Group 7-8 in Field 4 (04)	360 Secs [==>]	[1]

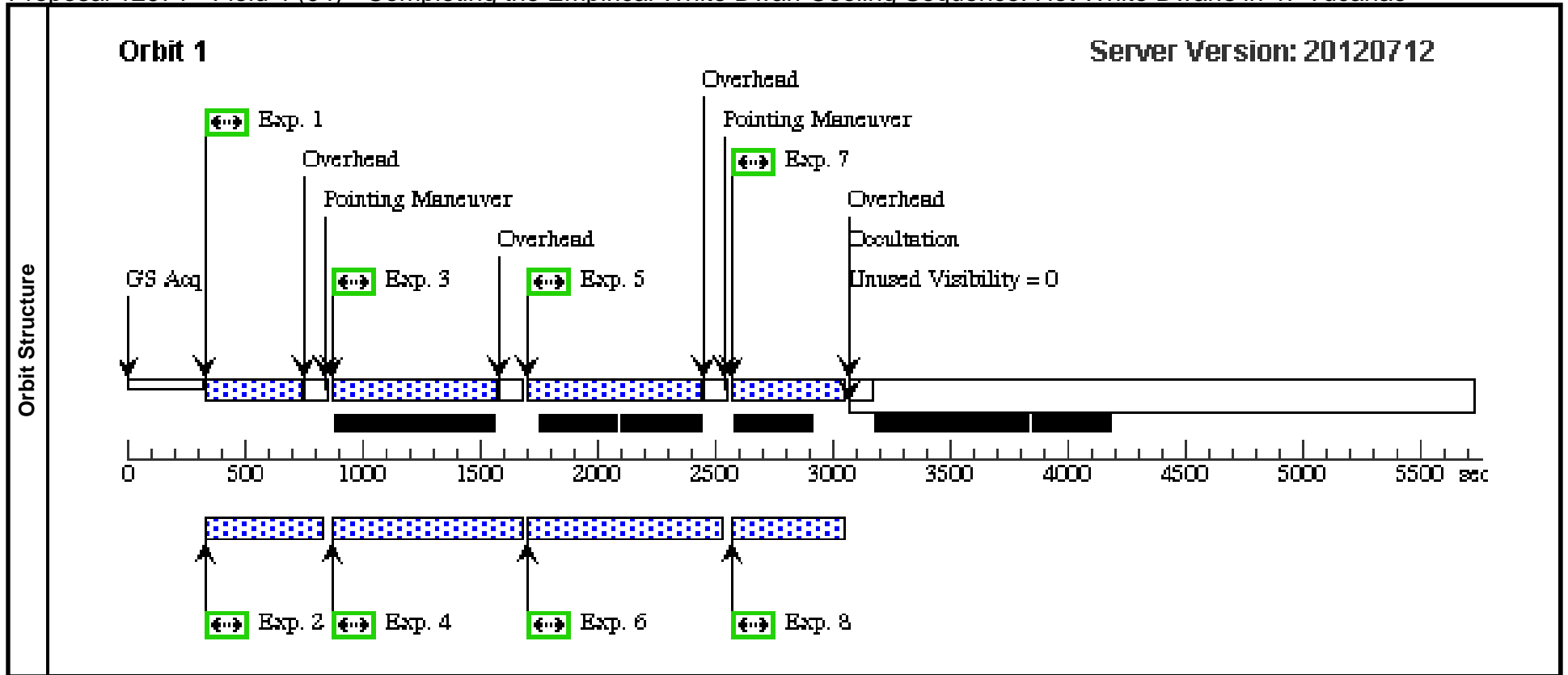

Proposal 12971 - Field 5 (05) - Completing the Empirical White Dwarf Cooling Sequence: Hot White Dwarfs in 47 Tucanae

Tue Aug 07 01:55:35 GMT 2012

Visit	<b>Proposal 12971, Field 5 (05), implementation</b> <b>Diagnostic Status: No Diagnostics</b> Scientific Instruments: WFC3/UVIS, ACS/WFC Special Requirements: SCHED 100%; ORIENT 190.D TO 190. D									
	Fixed Targets	#	Name	Target Coordinates	Targ. Coord. Corrections	Fluxes	Miscellaneous			
	(5)	47TUC-FIELD5	RA: 00 23 48.3720 (5.9515500d) Dec: -72 04 52.64 (-72.08129d) Equinox: J2000		V=3.95	Reference Frame: ICRS				
Exposures	#	Label	Target	Config,Mode,Aperture	Spectral Els.	Opt. Params.	Special Reqs.	Groups	Exp. Time/[Actual Dur.]	Orbit
	1	(5) 47TUC-FIELD5		WFC3/UVIS, ACCUM, UVIS	F225W		POS TARG 0,null	Prime + Parallel Group 1-2 in Field 5 (05)	380 Secs [==>]	[1]
	2	(5) 47TUC-FIELD5		ACS/WFC, ACCUM, WFC	F435W			Prime + Parallel Group 1-2 in Field 5 (05)	290 Secs [==>]	[1]
	3	(5) 47TUC-FIELD5		WFC3/UVIS, ACCUM, UVIS	F225W		POS TARG 5,5	Prime + Parallel Group 3-4 in Field 5 (05)	700 Secs [==>]	[1]
	4	(5) 47TUC-FIELD5		ACS/WFC, ACCUM, WFC	F435W			Prime + Parallel Group 3-4 in Field 5 (05)	690 Secs [==>]	[1]
	5	(5) 47TUC-FIELD5		WFC3/UVIS, ACCUM, UVIS	F336W		POS TARG 5,5	Prime + Parallel Group 5-6 in Field 5 (05)	720 Secs [==>]	[1]
	6	(5) 47TUC-FIELD5		ACS/WFC, ACCUM, WFC	F555W			Prime + Parallel Group 5-6 in Field 5 (05)	660 Secs [==>]	[1]
	7	(5) 47TUC-FIELD5		WFC3/UVIS, ACCUM, UVIS	F336W		POS TARG 0,0	Prime + Parallel Group 7-8 in Field 5 (05)	485 Secs [==>]	[1]
	8	(5) 47TUC-FIELD5		ACS/WFC, ACCUM, WFC	F555W			Prime + Parallel Group 7-8 in Field 5 (05)	360 Secs [==>]	[1]

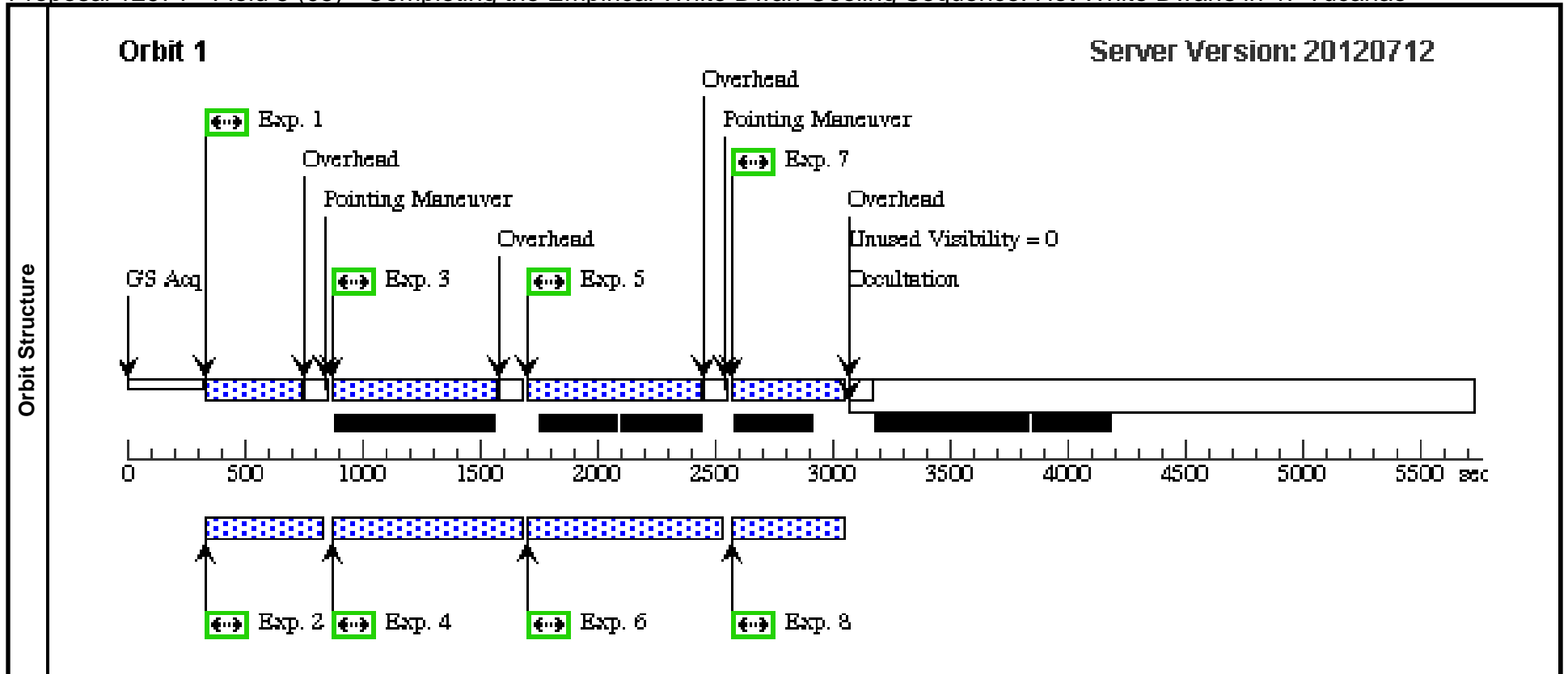

Proposal 12971 - Field 6 (06) - Completing the Empirical White Dwarf Cooling Sequence: Hot White Dwarfs in 47 Tucanae

Tue Aug 07 01:55:36 GMT 2012

Visit	<b>Proposal 12971, Field 6 (06), implementation</b> <b>Diagnostic Status: No Diagnostics</b> Scientific Instruments: WFC3/UVIS, ACS/WFC Special Requirements: SCHED 100%; ORIENT 226.D TO 226. D									
	Fixed Targets	#	Name	Target Coordinates	Targ. Coord. Corrections	Fluxes	Miscellaneous			
	(6)	47TUC-FIELD6	RA: 00 23 51.6816 (5.9653400d) Dec: -72 04 5.63 (-72.06823d) Equinox: J2000		V=3.95	Reference Frame: ICRS				
Exposures	#	Label	Target	Config,Mode,Aperture	Spectral Els.	Opt. Params.	Special Reqs.	Groups	Exp. Time/[Actual Dur.]	Orbit
	1	(6) 47TUC-FIELD6		WFC3/UVIS, ACCUM, UVIS	F225W		POS TARG 0,null	Prime + Parallel Group 1-2 in Field 6 (06)	380 Secs [==>]	[1]
	2	(6) 47TUC-FIELD6		ACS/WFC, ACCUM, WFC	F435W			Prime + Parallel Group 1-2 in Field 6 (06)	290 Secs [==>]	[1]
	3	(6) 47TUC-FIELD6		WFC3/UVIS, ACCUM, UVIS	F225W		POS TARG 5,5	Prime + Parallel Group 3-4 in Field 6 (06)	700 Secs [==>]	[1]
	4	(6) 47TUC-FIELD6		ACS/WFC, ACCUM, WFC	F435W			Prime + Parallel Group 3-4 in Field 6 (06)	690 Secs [==>]	[1]
	5	(6) 47TUC-FIELD6		WFC3/UVIS, ACCUM, UVIS	F336W		POS TARG 5,5	Prime + Parallel Group 5-6 in Field 6 (06)	720 Secs [==>]	[1]
	6	(6) 47TUC-FIELD6		ACS/WFC, ACCUM, WFC	F555W			Prime + Parallel Group 5-6 in Field 6 (06)	660 Secs [==>]	[1]
	7	(6) 47TUC-FIELD6		WFC3/UVIS, ACCUM, UVIS	F336W		POS TARG 0,0	Prime + Parallel Group 7-8 in Field 6 (06)	485 Secs [==>]	[1]
	8	(6) 47TUC-FIELD6		ACS/WFC, ACCUM, WFC	F555W			Prime + Parallel Group 7-8 in Field 6 (06)	360 Secs [==>]	[1]

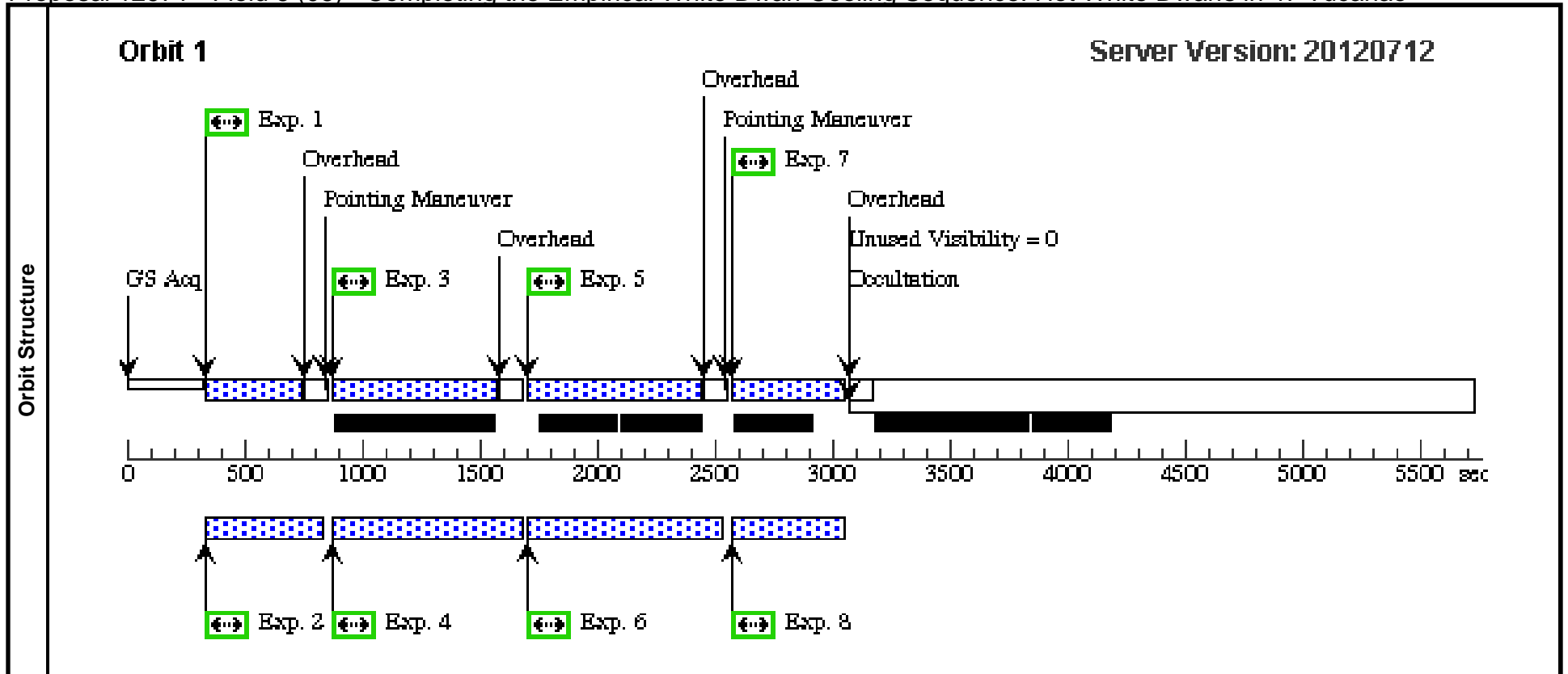

Proposal 12971 - Field 7 (07) - Completing the Empirical White Dwarf Cooling Sequence: Hot White Dwarfs in 47 Tucanae

Tue Aug 07 01:55:37 GMT 2012

Visit	<b>Proposal 12971, Field 7 (07), implementation</b> <b>Diagnostic Status: No Diagnostics</b> Scientific Instruments: WFC3/UVIS, ACS/WFC Special Requirements: SCHED 100%; ORIENT 262.D TO 262. D									
	Fixed Targets	#	Name	Target Coordinates	Targ. Coord. Corrections	Fluxes	Miscellaneous			
	(7)	47TUC-FIELD7	RA: 00 24 0.3504 (6.0014600d) Dec: -72 03 36.58 (-72.06016d) Equinox: J2000		V=3.95	Reference Frame: ICRS				
Exposures	#	Label	Target	Config,Mode,Aperture	Spectral Els.	Opt. Params.	Special Reqs.	Groups	Exp. Time/[Actual Dur.]	Orbit
	1	(7) 47TUC-FIELD7		WFC3/UVIS, ACCUM, UVIS	F225W		POS TARG 0,null	Prime + Parallel Group 1-2 in Field 7 (07)	380 Secs [==>]	[1]
	2	(7) 47TUC-FIELD7		ACS/WFC, ACCUM, WFC	F435W			Prime + Parallel Group 1-2 in Field 7 (07)	290 Secs [==>]	[1]
	3	(7) 47TUC-FIELD7		WFC3/UVIS, ACCUM, UVIS	F225W		POS TARG 5,5	Prime + Parallel Group 3-4 in Field 7 (07)	700 Secs [==>]	[1]
	4	(7) 47TUC-FIELD7		ACS/WFC, ACCUM, WFC	F435W			Prime + Parallel Group 3-4 in Field 7 (07)	690 Secs [==>]	[1]
	5	(7) 47TUC-FIELD7		WFC3/UVIS, ACCUM, UVIS	F336W		POS TARG 5,5	Prime + Parallel Group 5-6 in Field 7 (07)	720 Secs [==>]	[1]
	6	(7) 47TUC-FIELD7		ACS/WFC, ACCUM, WFC	F555W			Prime + Parallel Group 5-6 in Field 7 (07)	660 Secs [==>]	[1]
	7	(7) 47TUC-FIELD7		WFC3/UVIS, ACCUM, UVIS	F336W		POS TARG 0,0	Prime + Parallel Group 7-8 in Field 7 (07)	485 Secs [==>]	[1]
	8	(7) 47TUC-FIELD7		ACS/WFC, ACCUM, WFC	F555W			Prime + Parallel Group 7-8 in Field 7 (07)	360 Secs [==>]	[1]

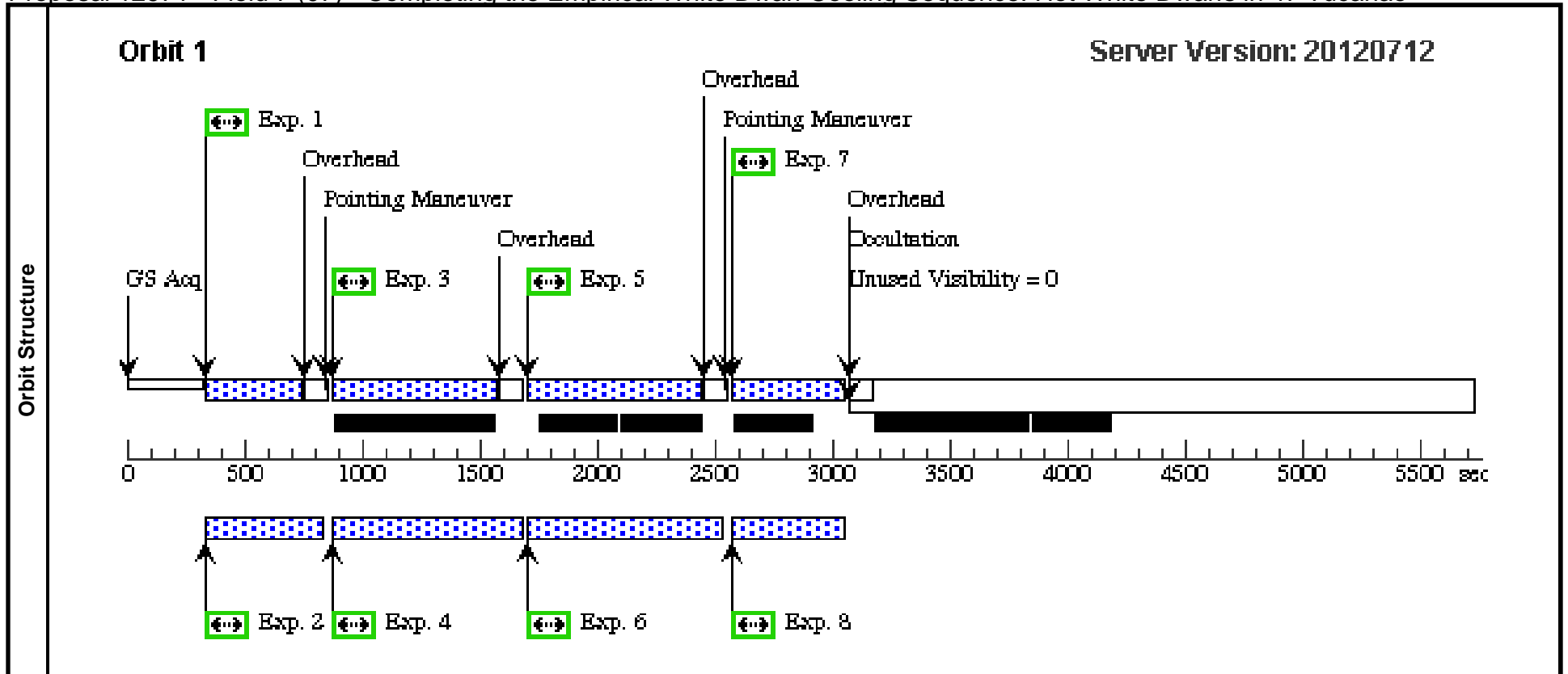

Proposal 12971 - Field 8 (08) - Completing the Empirical White Dwarf Cooling Sequence: Hot White Dwarfs in 47 Tucanae

Tue Aug 07 01:55:38 GMT 2012

Visit	<b>Proposal 12971, Field 8 (08), implementation</b> <b>Diagnostic Status: No Diagnostics</b> Scientific Instruments: WFC3/UVIS, ACS/WFC Special Requirements: SCHED 100%; ORIENT 298.D TO 298. D									
	Fixed Targets	#	Name	Target Coordinates	Targ. Coord. Corrections	Fluxes	Miscellaneous			
	(8)	47TUC-FIELD8	RA: 00 24 11.0616 (6.0460900d) Dec: -72 03 36.58 (-72.06016d) Equinox: J2000		V=3.95	Reference Frame: ICRS				
Exposures	#	Label	Target	Config,Mode,Aperture	Spectral Els.	Opt. Params.	Special Reqs.	Groups	Exp. Time/[Actual Dur.]	Orbit
	1	(8) 47TUC-FIELD8		WFC3/UVIS, ACCUM, UVIS	F225W		POS TARG 0,null	Prime + Parallel Group 1-2 in Field 8 (08)	380 Secs [==>]	[1]
	2	(8) 47TUC-FIELD8		ACS/WFC, ACCUM, WFC	F435W			Prime + Parallel Group 1-2 in Field 8 (08)	290 Secs [==>]	[1]
	3	(8) 47TUC-FIELD8		WFC3/UVIS, ACCUM, UVIS	F225W		POS TARG 5,5	Prime + Parallel Group 3-4 in Field 8 (08)	700 Secs [==>]	[1]
	4	(8) 47TUC-FIELD8		ACS/WFC, ACCUM, WFC	F435W			Prime + Parallel Group 3-4 in Field 8 (08)	690 Secs [==>]	[1]
	5	(8) 47TUC-FIELD8		WFC3/UVIS, ACCUM, UVIS	F336W		POS TARG 5,5	Prime + Parallel Group 5-6 in Field 8 (08)	720 Secs [==>]	[1]
	6	(8) 47TUC-FIELD8		ACS/WFC, ACCUM, WFC	F555W			Prime + Parallel Group 5-6 in Field 8 (08)	660 Secs [==>]	[1]
	7	(8) 47TUC-FIELD8		WFC3/UVIS, ACCUM, UVIS	F336W		POS TARG 0,0	Prime + Parallel Group 7-8 in Field 8 (08)	485 Secs [==>]	[1]
	8	(8) 47TUC-FIELD8		ACS/WFC, ACCUM, WFC	F555W			Prime + Parallel Group 7-8 in Field 8 (08)	360 Secs [==>]	[1]

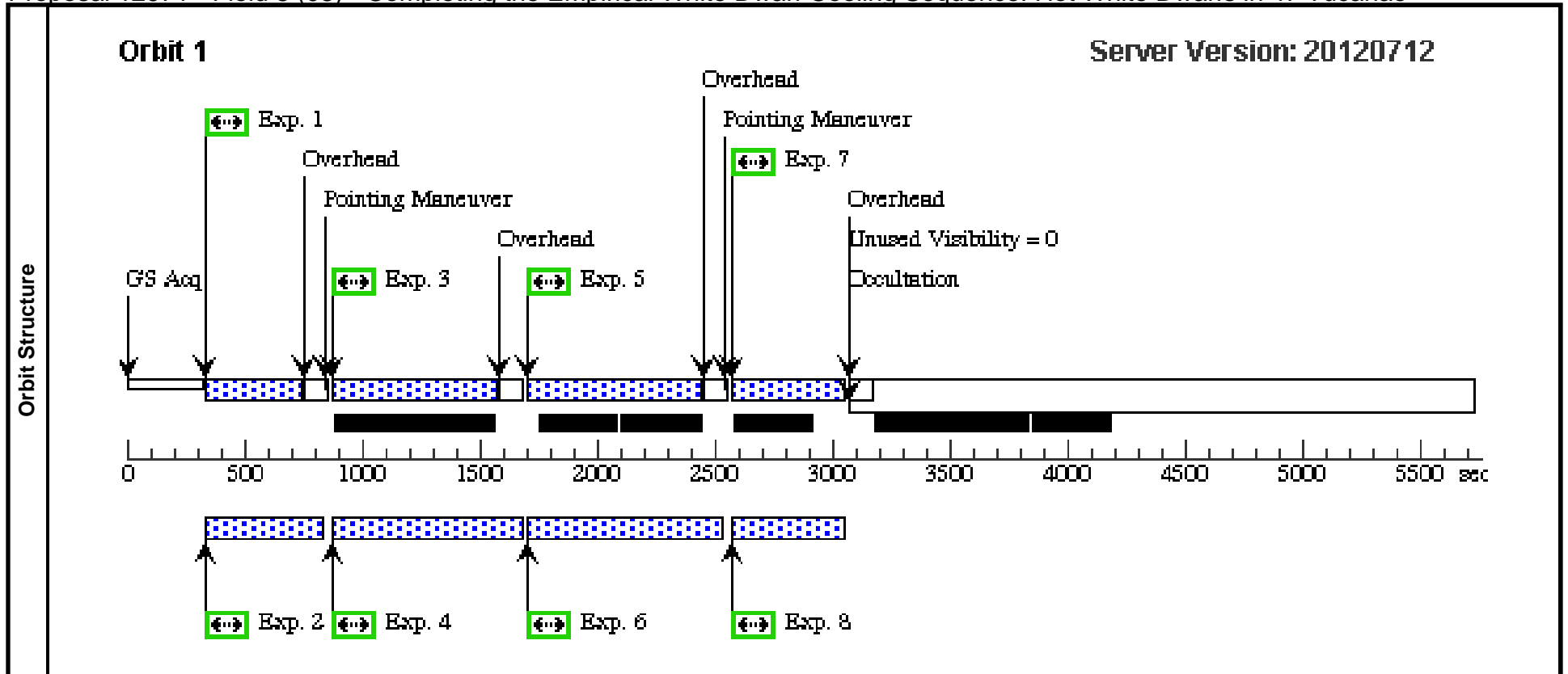

Proposal 12971 - Field 9 (09) - Completing the Empirical White Dwarf Cooling Sequence: Hot White Dwarfs in 47 Tucanae

Tue Aug 07 01:55:39 GMT 2012

Visit	<b>Proposal 12971, Field 9 (09), implementation</b> <b>Diagnostic Status: No Diagnostics</b> Scientific Instruments: WFC3/UVIS, ACS/WFC Special Requirements: SCHED 100%; ORIENT 334.D TO 334. D									
	Fixed Targets	#	Name	Target Coordinates	Targ. Coord. Corrections	Fluxes	Miscellaneous			
	(9)	47TUC-FIELD9	RA: 00 24 19.7304 (6.0822100d) Dec: -72 04 5.63 (-72.06823d) Equinox: J2000		V=3.95	Reference Frame: ICRS				
Exposures	#	Label	Target	Config,Mode,Aperture	Spectral Els.	Opt. Params.	Special Reqs.	Groups	Exp. Time/[Actual Dur.]	Orbit
	1	(9) 47TUC-FIELD9		WFC3/UVIS, ACCUM, UVIS	F225W		POS TARG 0,null	Prime + Parallel Group 1-2 in Field 9 (09)	380 Secs [==>]	[1]
	2	(9) 47TUC-FIELD9		ACS/WFC, ACCUM, WFC	F435W			Prime + Parallel Group 1-2 in Field 9 (09)	290 Secs [==>]	[1]
	3	(9) 47TUC-FIELD9		WFC3/UVIS, ACCUM, UVIS	F225W		POS TARG 5,5	Prime + Parallel Group 3-4 in Field 9 (09)	700 Secs [==>]	[1]
	4	(9) 47TUC-FIELD9		ACS/WFC, ACCUM, WFC	F435W			Prime + Parallel Group 3-4 in Field 9 (09)	690 Secs [==>]	[1]
	5	(9) 47TUC-FIELD9		WFC3/UVIS, ACCUM, UVIS	F336W		POS TARG 5,5	Prime + Parallel Group 5-6 in Field 9 (09)	720 Secs [==>]	[1]
	6	(9) 47TUC-FIELD9		ACS/WFC, ACCUM, WFC	F555W			Prime + Parallel Group 5-6 in Field 9 (09)	660 Secs [==>]	[1]
	7	(9) 47TUC-FIELD9		WFC3/UVIS, ACCUM, UVIS	F336W		POS TARG 0,0	Prime + Parallel Group 7-8 in Field 9 (09)	485 Secs [==>]	[1]
	8	(9) 47TUC-FIELD9		ACS/WFC, ACCUM, WFC	F555W			Prime + Parallel Group 7-8 in Field 9 (09)	360 Secs [==>]	[1]

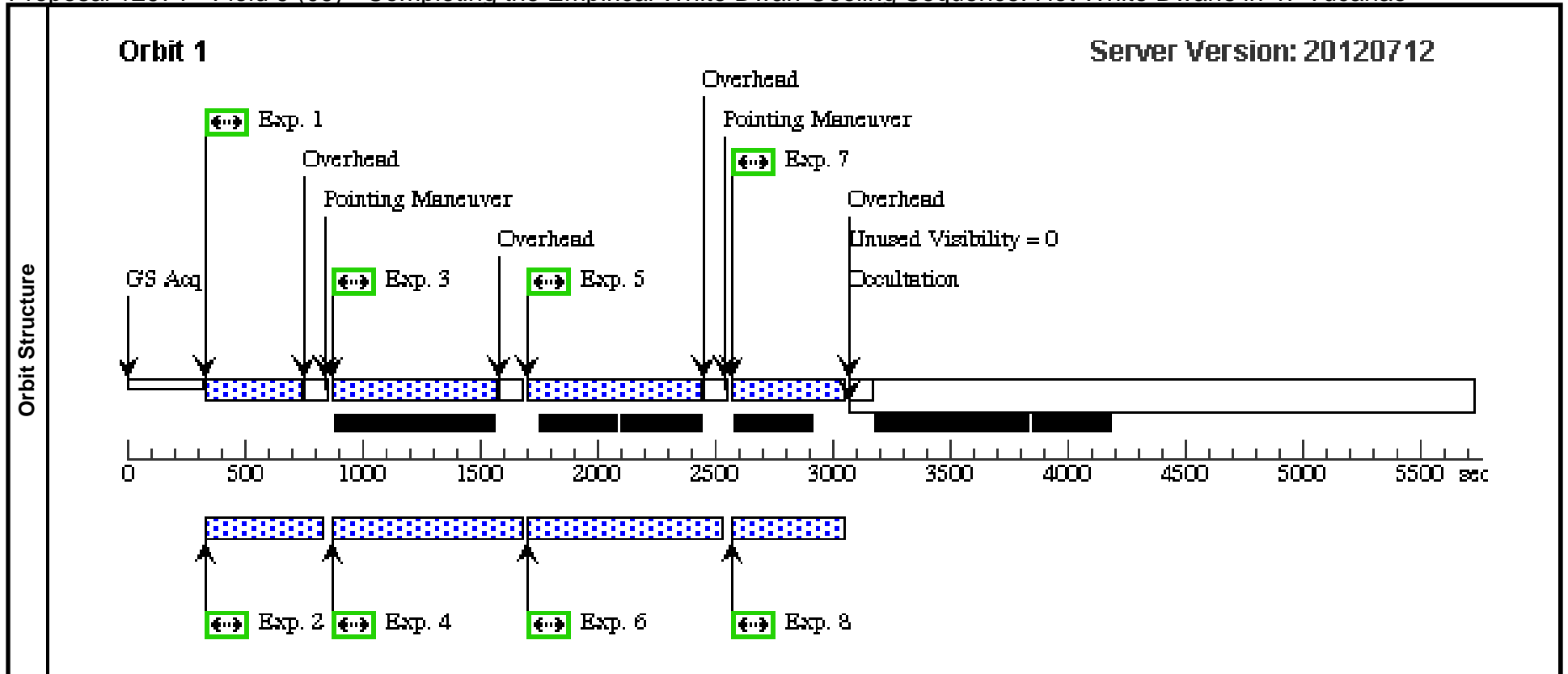

Proposal 12971 - Field 10 (10) - Completing the Empirical White Dwarf Cooling Sequence: Hot White Dwarfs in 47 Tucanae

Tue Aug 07 01:55:40 GMT 2012

Visit	<b>Proposal 12971, Field 10 (10), implementation</b> <b>Diagnostic Status: No Diagnostics</b> Scientific Instruments: WFC3/UVIS, ACS/WFC Special Requirements: SCHED 100%; ORIENT 5.D TO 5. D									
	Fixed Targets	#	Name	Target Coordinates	Targ. Coord. Corrections	Fluxes	Miscellaneous			
	(10)	47TUC-FIELD10	RA: 00 24 23.0400 (6.0960000d) Dec: -72 04 52.64 (-72.08129d) Equinox: J2000		V=3.95	Reference Frame: ICRS				
Exposures	#	Label	Target	Config,Mode,Aperture	Spectral Els.	Opt. Params.	Special Reqs.	Groups	Exp. Time/[Actual Dur.]	Orbit
	1	(10) 47TUC-FIELD10	(10) 47TUC-FIELD10	WFC3/UVIS, ACCUM, UVIS	F225W		POS TARG 0,null	Prime + Parallel Group 1-2 in Field 10 (10)	380 Secs [==>]	[1]
	2	(10) 47TUC-FIELD10	(10) 47TUC-FIELD10	ACS/WFC, ACCUM, WFC	F435W			Prime + Parallel Group 1-2 in Field 10 (10)	290 Secs [==>]	[1]
	3	(10) 47TUC-FIELD10	(10) 47TUC-FIELD10	WFC3/UVIS, ACCUM, UVIS	F225W		POS TARG 5,5	Prime + Parallel Group 3-4 in Field 10 (10)	700 Secs [==>]	[1]
	4	(10) 47TUC-FIELD10	(10) 47TUC-FIELD10	ACS/WFC, ACCUM, WFC	F435W			Prime + Parallel Group 3-4 in Field 10 (10)	690 Secs [==>]	[1]
	5	(10) 47TUC-FIELD10	(10) 47TUC-FIELD10	WFC3/UVIS, ACCUM, UVIS	F336W		POS TARG 5,5	Prime + Parallel Group 5-6 in Field 10 (10)	720 Secs [==>]	[1]
	6	(10) 47TUC-FIELD10	(10) 47TUC-FIELD10	ACS/WFC, ACCUM, WFC	F555W			Prime + Parallel Group 5-6 in Field 10 (10)	660 Secs [==>]	[1]
	7	(10) 47TUC-FIELD10	(10) 47TUC-FIELD10	WFC3/UVIS, ACCUM, UVIS	F336W		POS TARG 0,0	Prime + Parallel Group 7-8 in Field 10 (10)	485 Secs [==>]	[1]
	8	(10) 47TUC-FIELD10	(10) 47TUC-FIELD10	ACS/WFC, ACCUM, WFC	F555W			Prime + Parallel Group 7-8 in Field 10 (10)	360 Secs [==>]	[1]

