



# 13828 - Late nebular stage high resolution UV spectroscopy of classical Galactic novae: a benchmark panchromatic archive for nova evolution

Cycle: 22, Proposal Category: GO

(UV Initiative)

(Availability Mode: SUPPORTED)

## INVESTIGATORS

<i>Name</i>	<i>Institution</i>	<i>E-Mail</i>
<b>Dr. Steve Shore (PI) (ESA Member) (Contact)</b>	<b>Universita di Pisa</b>	<b>shore@df.unipi.it</b>
Dr. Gregory James Schwarz (CoI) (AdminUSPI) (Contact)	American Astronomical Society	greg.schwarz@aaas.org
Dr. Elena Mason (CoI) (ESA Member)	INAF, Osservatorio Astronomico di Trieste	emason@oats.inaf.it
Dr. Charles E. Woodward (CoI)	University of Minnesota - Twin Cities	chelsea@astro.umn.edu
Dr. Jan-Uwe Ness (CoI) (ESA Member)	European Space Agency - ESTEC	jness@sciops.esa.int
Dr. Robert D. Gehrz (CoI)	University of Minnesota - Twin Cities	gehrz@astro.umn.edu
Dr. Sumner G. Starrfield (CoI)	Arizona State University	sumner.starrfield@asu.edu
Dr. Kim Page (CoI) (ESA Member)	University of Leicester	kpa@star.le.ac.uk
Dr. Robert E. Williams (CoI)	Space Telescope Science Institute	wms@stsci.edu
Prof. Michael F. Bode (CoI) (ESA Member)	Liverpool John Moores University	mfb@astro.livjm.ac.uk
Dr. Julian P. Osborne (CoI) (ESA Member)	University of Leicester	julo@star.le.ac.uk
Dr. Jordi Jose' (CoI) (ESA Member)	Universitat Politecnica de Catalunya	jordi.jose@upc.edu
Dr. Massimo Della Valle (CoI) (ESA Member)	INAF, Osservatorio Astronomico di Capodimonte	dellavalle@na.astro.it
Dr. Luca Izzo (CoI) (ESA Member)	Universita di Roma La Sapienza	luca.izzo@gmail.com

## VISITS

<i>Visit</i>	<i>Targets used in Visit</i>	<i>Configurations used in Visit</i>	<i>Orbits Used</i>	<i>Last Orbit Planner Run</i>	<i>OP Current with Visit?</i>
01	(1) V959-MON	STIS/CCD STIS/FUV-MAMA	3	19-Nov-2015 21:07:22.0	yes
02	(1) V959-MON	STIS/CCD STIS/NUV-MAMA	2	19-Nov-2015 21:07:23.0	yes
03	(1) V959-MON	STIS/CCD STIS/FUV-MAMA STIS/NUV-MAMA	2	19-Nov-2015 21:07:25.0	yes
04	(3) V1369-CEN-2013	STIS/CCD STIS/FUV-MAMA STIS/NUV-MAMA	1	19-Nov-2015 21:07:26.0	yes
05	(3) V1369-CEN-2013	STIS/CCD STIS/FUV-MAMA STIS/NUV-MAMA	1	19-Nov-2015 21:07:27.0	yes
06	(3) V1369-CEN-2013	STIS/CCD STIS/FUV-MAMA STIS/NUV-MAMA	1	19-Nov-2015 21:07:28.0	yes
08	(2) V339-DEL	STIS/CCD STIS/FUV-MAMA STIS/NUV-MAMA	2	19-Nov-2015 21:07:30.0	yes
09	(2) V339-DEL	STIS/CCD STIS/FUV-MAMA STIS/NUV-MAMA	2	19-Nov-2015 21:07:31.0	yes
59	(2) V339-DEL	STIS/CCD STIS/FUV-MAMA STIS/NUV-MAMA	2	19-Nov-2015 21:07:33.0	yes

16 Total Orbits Used

**ABSTRACT**

The major obstacle to understanding the classical nova phenomenon is the lack of systematic observations, primarily spectroscopic, through the various stages of the ejecta and white dwarf evolution. Progress is only possible if long term, coordinated multi-wavelength spectroscopic data at high spectral resolution and high signal to noise are available. Our objective is to use HST/STIS spectra, along with coordinated space- and ground-based observations, to fully characterize three bright recent Galactic classical novae within a panchromatic framework. This proposed data set will be a benchmark sample for any future modeling efforts. All three, V959 Mon (ONe type), V339 Del (CO-type), and V1369 Cen (CO-type), were detected in gamma-rays by Fermi/LAT and well observed in the first months after outburst. We propose to use these data to address fundamental unsolved problems, such as: the origin of the large-scale bipolar structure, the origin and time development of the fragmentation detected in the ejecta, the uniformity of the abundances among the emission knots, and the determination of filling factors and masses for the ejecta. All are essential for understanding the thermonuclear explosion on the white dwarf and its related hydrodynamic events.

## **OBSERVING DESCRIPTION**

Multiple UV visits are required to observe the changes as the ejecta expand and the central source evolves. One E140M and two E230M (c: 1978 A and 2707 A) exposures will provide the continuous UV coverage (1123 A to 3111 A) we require for the spectral sequence. The E140M provides access to resonance transitions of many ionization stages, e.g., C II - C IV, N IV-V, O III], and Ne IV]-V], along with the He II 1640 A and other excited state lines. The E230M short wavelength will provide C II, N III] and C III] emission, and the E230M long will provide Mg II, O III, and the Fe II lines.

For V1369 Cen we request four (4) separate one-orbit HST/STIS visits during cycles 22 and 23 to capture the same epochs obtained with V339 Del. Two exposures will be obtained in the current cycle 21 ending just before the start of the next cycle. We expect that during cycle 22 the brightness will still be sufficient in the UV, without risk to the detectors, to obtain a medium resolution sequence within a single orbit based on our experience with V339 Del. At the moment the source is still increasing in X-rays so we do not yet know when the SSS phase will either start or end. Thus, we request the longest possible period for the sequence. We expect this source to be observable with STIS for at least two years (to the end of Cycle 23), permitting an extraordinary view of the later stages with only modest observing times.

For V959 Mon, since the nova is now at a steady stage, we request a single epoch/visit with all three settings of the echelle gratings, each lasting two orbits (i.e. a total of 6 orbits). Since HST operation imposes a limit of 5 orbits per visit, the V959 Mon observation can be split into 2 or 3 relatively closely timed visits increasing to 7 the number of requested orbits (due to the extra acquisition). The exposure time is based on scaling from the T Pyx sequence after Day 600 scaled to the higher UV reddening ( $E(B-V) \sim 0.8$  compared to  $E(B-V) \sim 0.5$  for T Pyx). Only one sequence is requested,

Proposal 13828 (STScI Edit Number: 0, Created: Thursday, November 19, 2015 9:07:34 PM EST) - Overview

this will suffice to provide a baseline similar to that obtained in T Pyx after outburst. The previous STIS sequence, taken on Day 151, provides a sufficient comparison and baseline, especially for the interstellar spectrum.

For V339 Del, request two (2) additional visits. The period of invisibility of the source should occur in the first half of cycle 22 so we request one immediately after the first appearance (Feb-Mar 2015) and one near the end of the cycle. We expect that at the rate of decline of the nova each sequence will require two orbits for a total of four (4) orbits.

Proposal 13828 - Mon EPOCH 1a (01) - Late nebular stage high resolution UV spectroscopy of classical Galactic novae: a benchmark...

Fri Nov 20 02:07:34 GMT 2015

<b>Visit</b>	<b>Proposal 13828, Mon EPOCH 1a (01), completed</b> <b>Diagnostic Status: Warning</b> Scientific Instruments: STIS/CCD, STIS/FUV-MAMA Special Requirements: BETWEEN 14-JAN-2015:00:00:00 AND 16-APR-2015:00:00:00: GROUP 01,02,03 WITHIN 5D											
	(Mon EPOCH 1a (01)) Warning (Orbit Planner): ORBITAL VISIBILITY OVERRUN (Mon EPOCH 1a (01)) Warning (Orbit Planner): ORBITAL VISIBILITY OVERRUN (Mon EPOCH 1a (01)) Warning (Orbit Planner): ORBITAL VISIBILITY OVERRUN											
<b>Fixed Targets</b>	<b>#</b>	<b>Name</b>	<b>Target Coordinates</b>		<b>Targ. Coord. Corrections</b>		<b>Fluxes</b>	<b>Miscellaneous</b>				
	(1)	V959-MON	RA: 06 39 38.7400 (99.9114167d) Dec: +05 53 52.00 (5.89778d) Equinox: J2000				V=16.2+/-0.5	Reference Frame: ICRS				
<i>Comments: This object was generated by the targetselector and retrieved from the SIMBAD database.</i>												
<b>Exposures</b>	<b>#</b>	<b>Label (ETC Run)</b>	<b>Target</b>	<b>Config,Mode,Aperture</b>	<b>Spectral Els.</b>	<b>Opt. Params.</b>	<b>Special Reqs.</b>	<b>Groups</b>	<b>Exp. Time (Total)/[Actual Dur.]</b>		<b>Orbit</b>	
	1		(1) V959-MON	STIS/CCD, ACQ, 50CCD	MIRROR				2 Secs (2 Secs)			
									[==>]		[1]	
	2	(626022)	(1) V959-MON	STIS/FUV-MAMA, ACCUM, 0.2X0.2	E140M 1425 A					2441 Secs (2441 Secs)		
									[==>]		[1]	
	<i>Comments: the input spectrum in the ETC simulation is nova Mon itslef observed with STIS (same setup) when much brighter (V~10.5 on Nov 2012). The nova will be much fainter a the time of the cycle 22 observations (currently Jul 24 2014 it is at V~15.4 mag).</i>											
3	(626022)	(1) V959-MON	STIS/FUV-MAMA, ACCUM, 0.2X0.2	E140M 1425 A					2970 Secs (2970 Secs)			
								[==>]		[2]		
<i>Comments: the input spectrum in the ETC simulation is nova Mon itslef observed with STIS (same setup) when much brighter (V~10.5 on Nov 2012). The nova will be much fainter a the time of the cycle 22 observations (currently Jul 24 2014 it is at V~15.4 mag).</i>												
4	(626022)	(1) V959-MON	STIS/FUV-MAMA, ACCUM, 0.2X0.2	E140M 1425 A					2970 Secs (2970 Secs)			
								[==>]		[3]		
<i>Comments: the input spectrum in the ETC simulation is nova Mon itslef observed with STIS (same setup) when much brighter (V~10.5 on Nov 2012). The nova will be much fainter a the time of the cycle 22 observations (currently Jul 24 2014 it is at V~15.4 mag).</i>												

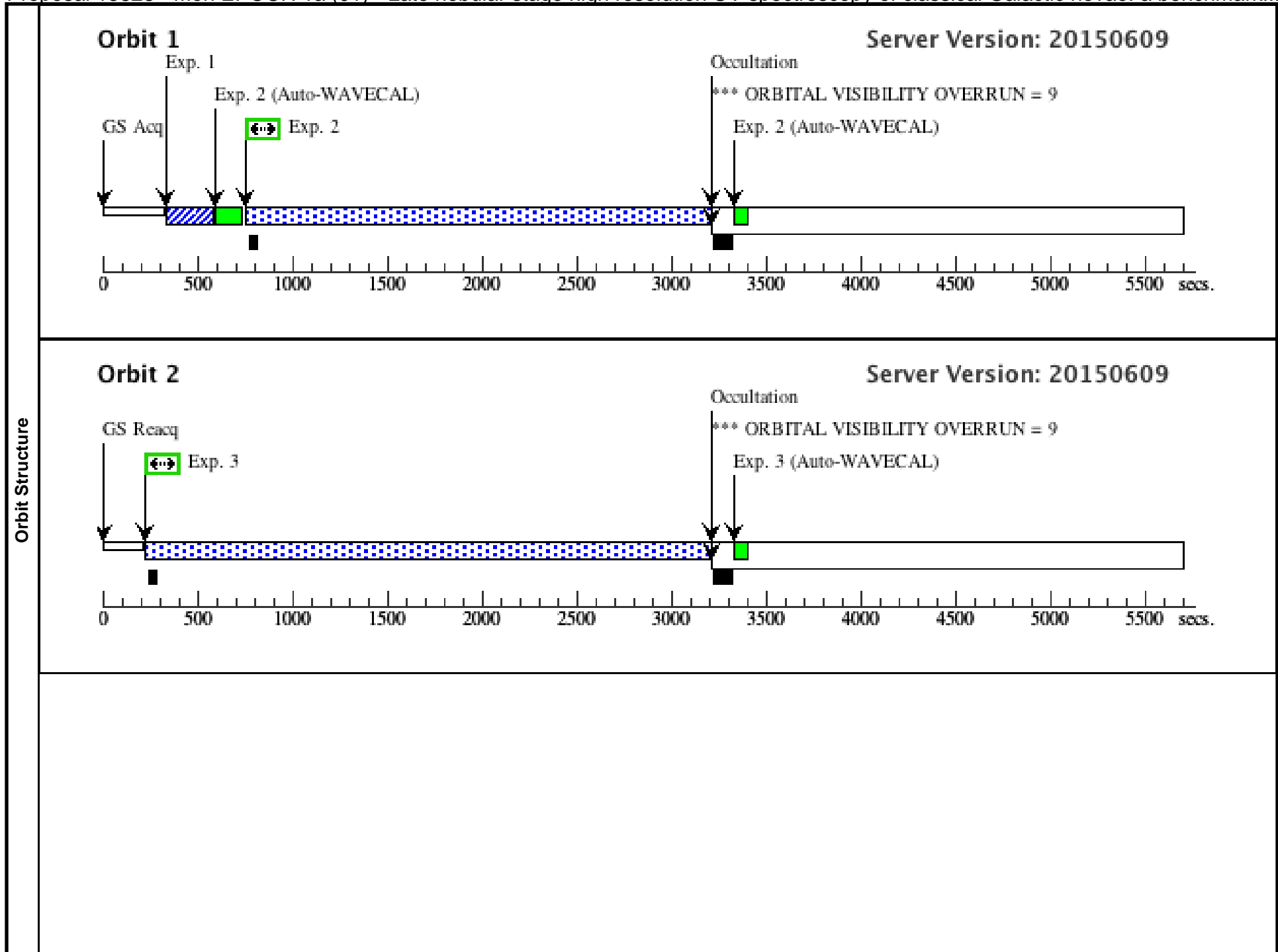

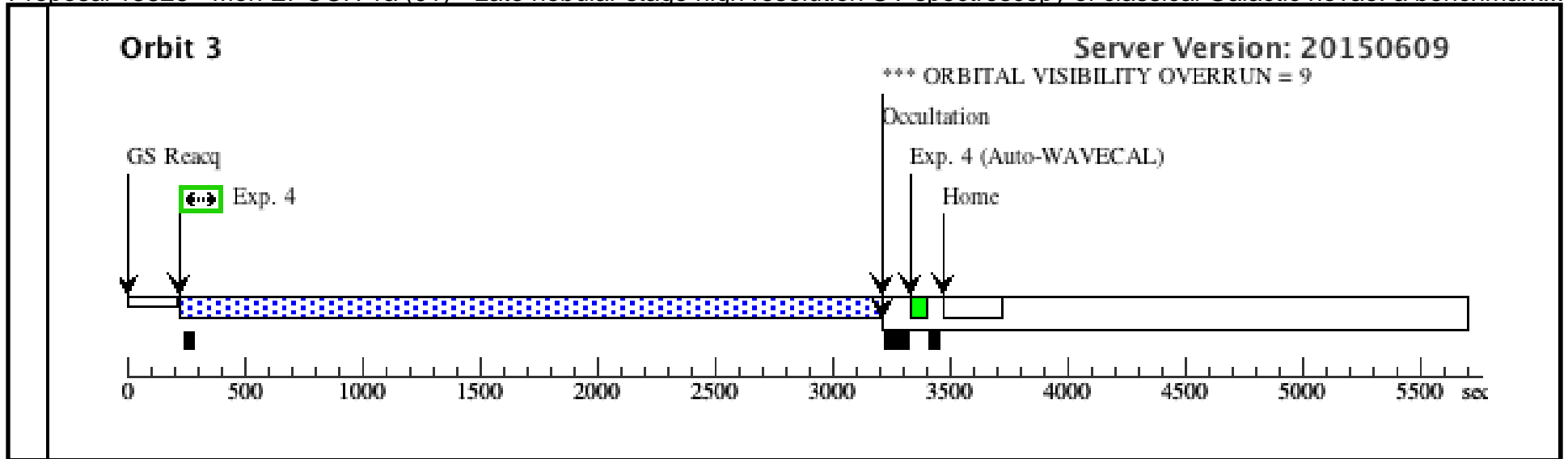

Proposal 13828 - Mon EPOCH 1b (02) - Late nebular stage high resolution UV spectroscopy of classical Galactic novae: a benchmark...

Fri Nov 20 02:07:34 GMT 2015

<b>Visit</b>	<b>Proposal 13828, Mon EPOCH 1b (02), completed</b> <b>Diagnostic Status: Warning</b> Scientific Instruments: STIS/NUV-MAMA, STIS/CCD Special Requirements: BETWEEN 14-JAN-2015:00:00:00 AND 16-APR-2015:00:00:00: GROUP 02,01,03 WITHIN 5D									
	(Mon EPOCH 1b (02)) Warning (Orbit Planner): ORBITAL VISIBILITY OVERRUN (Mon EPOCH 1b (02)) Warning (Orbit Planner): ORBITAL VISIBILITY OVERRUN									
<b>Diagnosics</b>										
<b>Fixed Targets</b>	<b>#</b>	<b>Name</b>	<b>Target Coordinates</b>	<b>Targ. Coord. Corrections</b>	<b>Fluxes</b>	<b>Miscellaneous</b>				
	(1)	V959-MON	RA: 06 39 38.7400 (99.9114167d) Dec: +05 53 52.00 (5.89778d) Equinox: J2000		V=16.2+/-0.5	Reference Frame: ICRS				
<i>Comments: This object was generated by the targetselector and retrieved from the SIMBAD database.</i>										
<b>Exposures</b>	<b>#</b>	<b>Label (ETC Run)</b>	<b>Target</b>	<b>Config,Mode,Aperture</b>	<b>Spectral Els.</b>	<b>Opt. Params.</b>	<b>Special Reqs.</b>	<b>Groups</b>	<b>Exp. Time (Total)/[Actual Dur.]</b>	<b>Orbit</b>
	1		(1) V959-MON	STIS/CCD, ACQ, 50CCD	MIRROR				2 Secs (2 Secs)	
									[==>]	[1]
	2	(626026)	(1) V959-MON	STIS/NUV-MAMA, ACCUM, 0.2X0.2	E230M 1978 A				2411 Secs (2411 Secs)	
									[==>]	[1]
<i>Comments: the input spectrum in the ETC simulation is nova Mon itslef observed with STIS (same setup) when much brighter (V~10.5 on Nov 2012). The nova will be much fainter a the time of the cycle 22 observations (currently Jul 24 2014 it is at V~15.4 mag.</i>										
	3	(626026)	(1) V959-MON	STIS/NUV-MAMA, ACCUM, 0.2X0.2	E230M 1978 A				2970 Secs (2970 Secs)	
								[==>]	[2]	
<i>Comments: the input spectrum in the ETC simulation is nova Mon itslef observed with STIS (same setup) when much brighter (V~10.5 on Nov 2012). The nova will be much fainter a the time of the cycle 22 observations (currently Jul 24 2014 it is at V~15.4 mag.</i>										

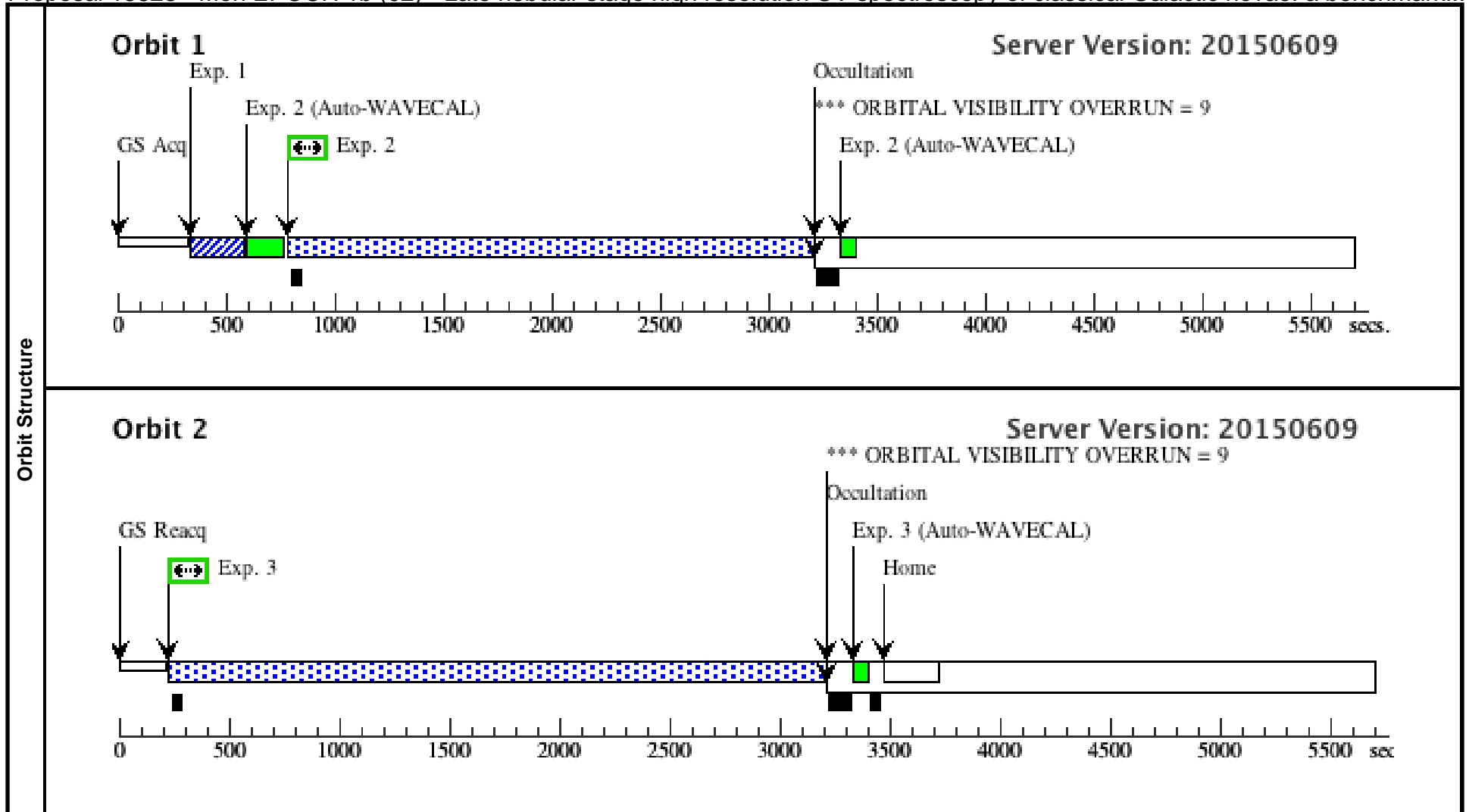

Proposal 13828 - Mon EPOCH 1c (03) - Late nebular stage high resolution UV spectroscopy of classical Galactic novae: a benchmark...

Fri Nov 20 02:07:34 GMT 2015

<b>Visit</b>	<b>Proposal 13828, Mon EPOCH 1c (03), completed</b> <b>Diagnostic Status: Warning</b> Scientific Instruments: STIS/NUV-MAMA, STIS/CCD, STIS/FUV-MAMA Special Requirements: BETWEEN 14-JAN-2015:00:00:00 AND 16-APR-2015:00:00:00: GROUP 03.01.02 WITHIN 5D									
	(Mon EPOCH 1c (03)) Warning (Orbit Planner): ORBITAL VISIBILITY OVERRUN (Mon EPOCH 1c (03)) Warning (Orbit Planner): ORBITAL VISIBILITY OVERRUN									
<b>Diagnosics</b>										
<b>Fixed Targets</b>	<b>#</b>	<b>Name</b>	<b>Target Coordinates</b>	<b>Targ. Coord. Corrections</b>	<b>Fluxes</b>	<b>Miscellaneous</b>				
	(1)	V959-MON	RA: 06 39 38.7400 (99.9114167d) Dec: +05 53 52.00 (5.89778d) Equinox: J2000		V=16.2+/-0.5	Reference Frame: ICRS				
<i>Comments: This object was generated by the targetselector and retrieved from the SIMBAD database.</i>										
<b>Exposures</b>	<b>#</b>	<b>Label (ETC Run)</b>	<b>Target</b>	<b>Config,Mode,Aperture</b>	<b>Spectral Els.</b>	<b>Opt. Params.</b>	<b>Special Reqs.</b>	<b>Groups</b>	<b>Exp. Time (Total)/[Actual Dur.]</b>	<b>Orbit</b>
	1		(1) V959-MON	STIS/CCD, ACQ, 50CCD	MIRROR				2 Secs (2 Secs)	
									[==>]	[1]
	2	(626022)	(1) V959-MON	STIS/FUV-MAMA, ACCUM, 0.2X0.2	E140M 1425 A				2441 Secs (2441 Secs)	
									[==>]	[1]
<i>Comments: the input spectrum in the ETC simulation is nova Mon itslef observed with STIS (same setup) when much brighter (V~10.5 on Nov 2012). The nova will be much fainter a the time of the cycle 22 observations (currently Jul 24 2014 it is at V~15.4 mag.</i>										
	3	(626027)	(1) V959-MON	STIS/NUV-MAMA, ACCUM, 0.2X0.2	E230M 2707 A				2970 Secs (2970 Secs)	
								[==>]	[2]	
<i>Comments: the input spectrum in the ETC simulation is nova Mon itslef observed with STIS (same setup) when much brighter (V~10.5 on Nov 2012). The nova will be much fainter a the time of the cycle 22 observations (currently Jul 24 2014 it is at V~15.4 mag.</i>										

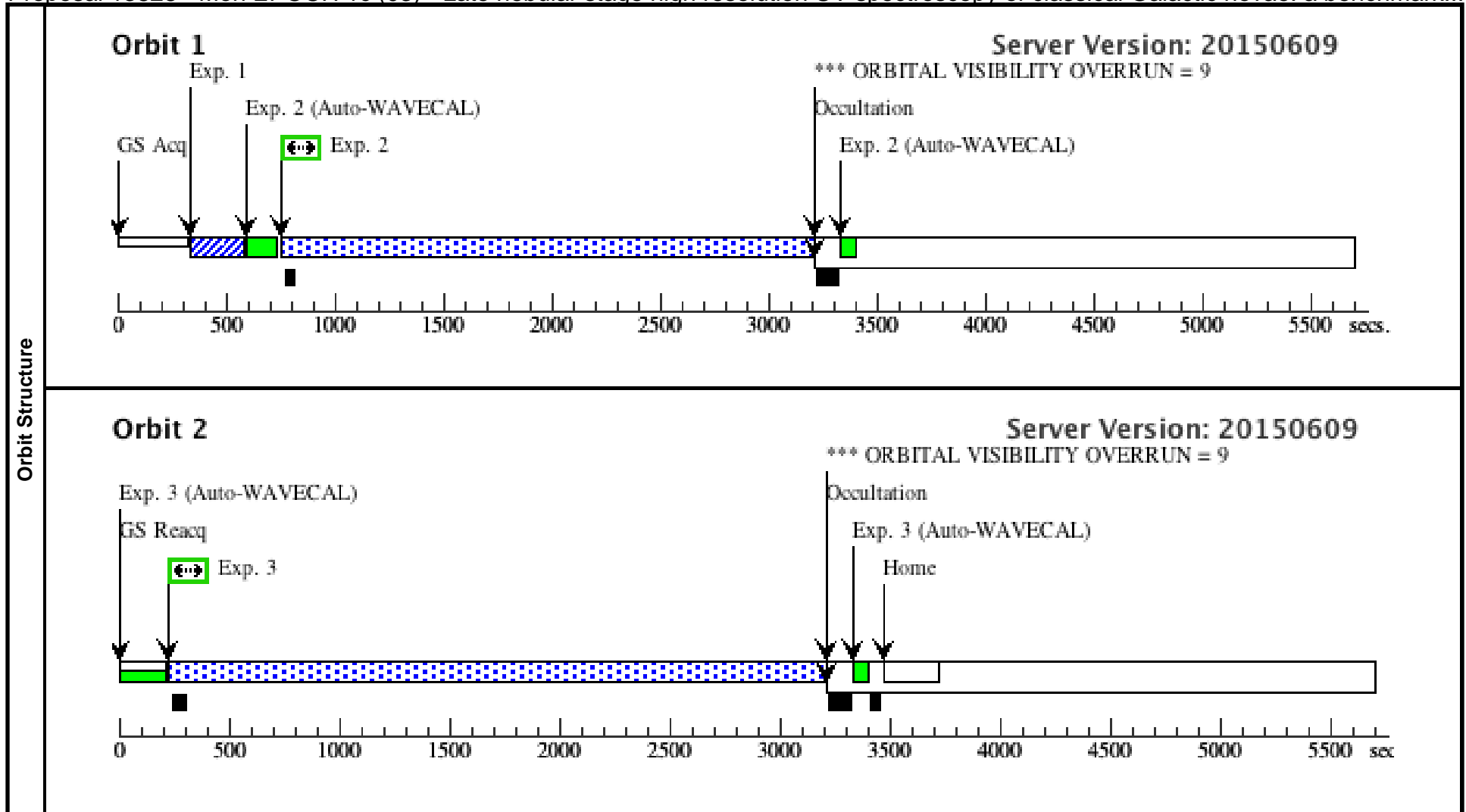

Proposal 13828 - Cen 1st EPOCH (04) - Late nebular stage high resolution UV spectroscopy of classical Galactic novae: a benchmark...

Fri Nov 20 02:07:34 GMT 2015

<b>Visit</b>	<b>Proposal 13828, Cen 1st EPOCH (04), completed</b> <b>Diagnostic Status: Warning</b> Scientific Instruments: STIS/NUV-MAMA, STIS/CCD, STIS/FUV-MAMA Special Requirements: BETWEEN 27-FEB-2015:00:00:00 AND 15-MAR-2015:00:00:00									
	(Cen 1st EPOCH (04)) Warning (Orbit Planner): ORBITAL VISIBILITY OVERRUN									
<b>Diagnosics</b>										
<b>Fixed Targets</b>	<b>#</b>	<b>Name</b>	<b>Target Coordinates</b>	<b>Targ. Coord. Corrections</b>	<b>Fluxes</b>	<b>Miscellaneous</b>				
	(3)	V1369-CEN-2013	RA: 13 54 45.3400 (208.6889167d) Dec: -59 09 4.20 (-59.15117d) Equinox: J2000		V=9.5+/-0.5	Reference Frame: ICRS				
<b>Exposures</b>	<b>#</b>	<b>Label (ETC Run)</b>	<b>Target</b>	<b>Config,Mode,Aperture</b>	<b>Spectral Els.</b>	<b>Opt. Params.</b>	<b>Special Reqs.</b>	<b>Groups</b>	<b>Exp. Time (Total)/[Actual Dur.]</b>	<b>Orbit</b>
	1		(3) V1369-CEN-2013	STIS/CCD, ACQ, 50CCD	MIRROR				1 Secs (1 Secs)	
									[==>]	[1]
	2	(625971)	(3) V1369-CEN-2013	STIS/FUV-MAMA, ACCUM, 0.2X0.2	E140M 1425 A				800 Secs (800 Secs)	
									[==>]	[1]
	<i>Comments: the input spectrum in the ETC is the stis/FUV/E140M spectrum of nova Del 2013 when at 11 mag. Cen 2013 and Del 2013 are two very alike noave in type (CO-WD) and spectral evolution. Cen is suppose d to be at the same mag in Dec 2014. Our first obs is in Feb 2015, when it will be even fainter.</i>									
3	(626117)	(3) V1369-CEN-2013	STIS/NUV-MAMA, ACCUM, 0.2X0.2	E230M 1978 A				602 Secs (602 Secs)		
								[==>]	[1]	
<i>Comments: the input spectrum in the ETC is the stis/NUV/E230M/1978 spectrum of nova Del 2013 when at 11 mag. Cen 2013 and Del 2013 are two very alike noave in type (CO-WD) and spectral evolution. Cen is supposed to be at the same mag in Dec 2014. Our first obs is in Feb 2015, when it will be even fainter.</i>										
4	(626030)	(3) V1369-CEN-2013	STIS/NUV-MAMA, ACCUM, 0.2X0.2	E230M 2707 A				601 Secs (601 Secs)		
								[==>]	[1]	
<i>Comments: the input spectrum in the ETC is the stis/NUV/E230M/2070 spectrum of nova Del 2013 when at 11 mag. Cen 2013 and Del 2013 are two very alike noave in type (CO-WD) and spectral evolution. Cen is supposed to be at the same mag in Dec 2014. Our first obs is in Feb 2015, when it will be even fainter.</i>										

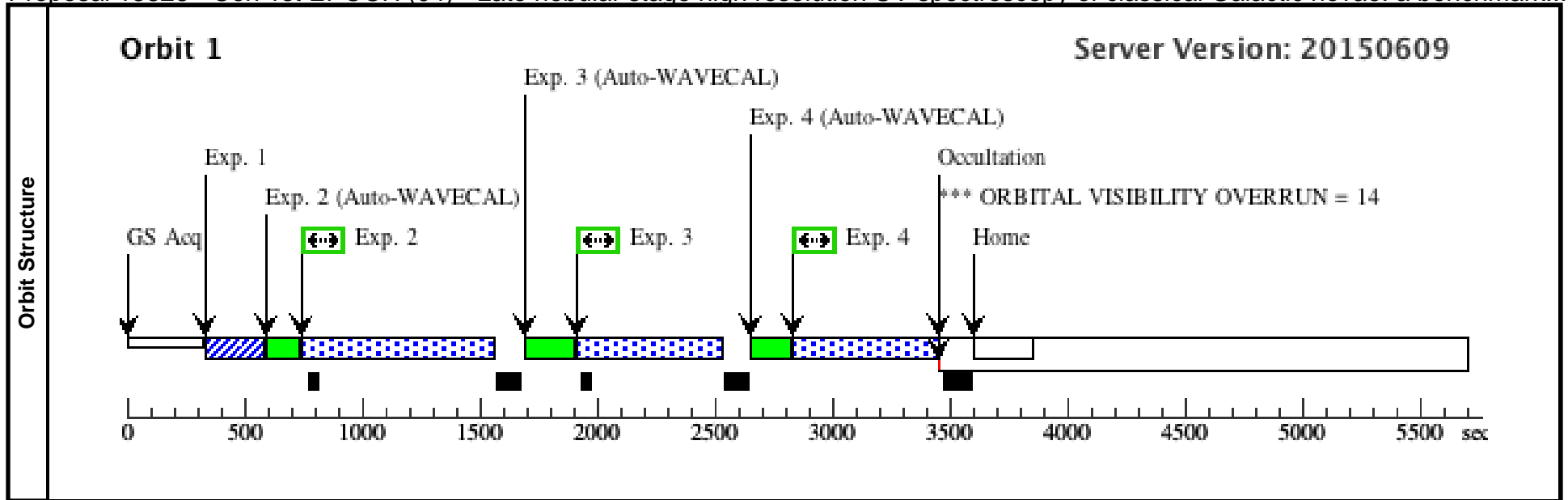

Proposal 13828 - Cen 2nd EPOCH (05) - Late nebular stage high resolution UV spectroscopy of classical Galactic novae: a benchmark...

Fri Nov 20 02:07:34 GMT 2015

<b>Visit</b>	<b>Proposal 13828, Cen 2nd EPOCH (05), completed</b> <b>Diagnostic Status: Warning</b> Scientific Instruments: STIS/NUV-MAMA, STIS/CCD, STIS/FUV-MAMA Special Requirements: BETWEEN 06-JUN-2015:00:00:00 AND 27-JUN-2015:00:00:00									
	(Cen 2nd EPOCH (05)) Warning (Orbit Planner): ORBITAL VISIBILITY OVERRUN									
<b>Diagnosics</b>										
<b>Fixed Targets</b>	<b>#</b>	<b>Name</b>	<b>Target Coordinates</b>	<b>Targ. Coord. Corrections</b>	<b>Fluxes</b>	<b>Miscellaneous</b>				
	(3)	V1369-CEN-2013	RA: 13 54 45.3400 (208.6889167d) Dec: -59 09 4.20 (-59.15117d) Equinox: J2000		V=9.5+/-0.5	Reference Frame: ICRS				
<b>Exposures</b>	<b>#</b>	<b>Label (ETC Run)</b>	<b>Target</b>	<b>Config,Mode,Aperture</b>	<b>Spectral Els.</b>	<b>Opt. Params.</b>	<b>Special Reqs.</b>	<b>Groups</b>	<b>Exp. Time (Total)/[Actual Dur.]</b>	<b>Orbit</b>
	1		(3) V1369-CEN-2013	STIS/CCD, ACQ, 50CCD	MIRROR				1 Secs (1 Secs)	
									[==>]	[1]
	2	(625971)	(3) V1369-CEN-2013	STIS/FUV-MAMA, ACCUM, 0.2X0.2	E140M 1425 A				800 Secs (800 Secs)	
									[==>]	[1]
	<i>Comments: the input spectrum in the ETC is the stis/FUV/E140M spectrum of nova Del 2013 when at 11 mag. Cen 2013 and Del 2013 are two very alike noave in type (CO-WD) and spectral evolution. Cen is suppose d to be at the same mag in Dec 2014. Our first obs is in Feb 2015, when it will be even fainter.</i>									
3	(626117)	(3) V1369-CEN-2013	STIS/NUV-MAMA, ACCUM, 0.2X0.2	E230M 1978 A				602 Secs (602 Secs)		
								[==>]	[1]	
<i>Comments: the input spectrum in the ETC is the stis/NUV/E230M/1978 spectrum of nova Del 2013 when at 11 mag. Cen 2013 and Del 2013 are two very alike noave in type (CO-WD) and spectral evolution. Cen is supposed to be at the same mag in Dec 2014. Our first obs is in Feb 2015, when it will be even fainter.</i>										
4	(626030)	(3) V1369-CEN-2013	STIS/NUV-MAMA, ACCUM, 0.2X0.2	E230M 2707 A				601 Secs (601 Secs)		
								[==>]	[1]	
<i>Comments: the input spectrum in the ETC is the stis/NUV/E230M/2070 spectrum of nova Del 2013 when at 11 mag. Cen 2013 and Del 2013 are two very alike noave in type (CO-WD) and spectral evolution. Cen is supposed to be at the same mag in Dec 2014. Our first obs is in Feb 2015, when it will be even fainter.</i>										

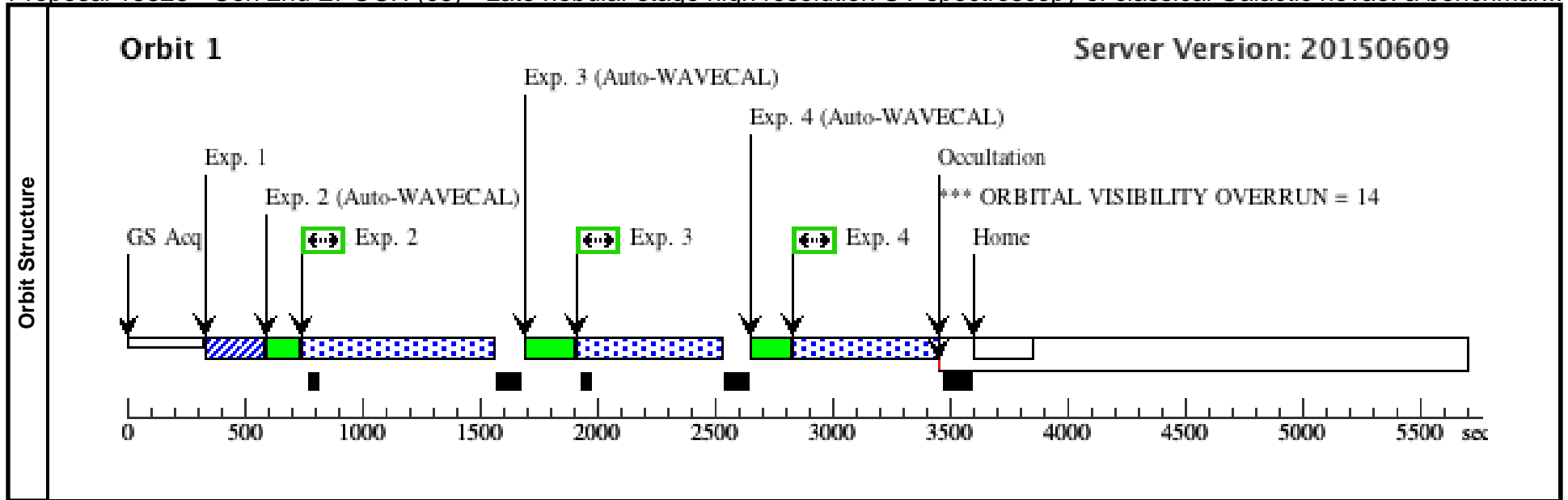

Proposal 13828 - Cen 3rd EPOCH (06) - Late nebular stage high resolution UV spectroscopy of classical Galactic novae: a benchmark...

Fri Nov 20 02:07:35 GMT 2015

<b>Visit</b>	<b>Proposal 13828, Cen 3rd EPOCH (06), withdrawn</b> <b>Diagnostic Status: Warning</b> Scientific Instruments: STIS/NUV-MAMA, STIS/CCD, STIS/FUV-MAMA Special Requirements: BETWEEN 01-FEB-2016:00:00:00 AND 31-MAR-2016:00:00:00										
	(Cen 3rd EPOCH (06)) Warning (Orbit Planner): ORBITAL VISIBILITY OVERRUN										
<b>Diagnosics</b>											
<b>Fixed Targets</b>	<b>#</b>	<b>Name</b>	<b>Target Coordinates</b>	<b>Targ. Coord. Corrections</b>	<b>Fluxes</b>	<b>Miscellaneous</b>					
	(3)	V1369-CEN-2013	RA: 13 54 45.3400 (208.6889167d) Dec: -59 09 4.20 (-59.15117d) Equinox: J2000		V=9.5+/-0.5	Reference Frame: ICRS					
<b>Exposures</b>	<b>#</b>	<b>Label (ETC Run)</b>	<b>Target</b>	<b>Config,Mode,Aperture</b>	<b>Spectral Els.</b>	<b>Opt. Params.</b>	<b>Special Reqs.</b>	<b>Groups</b>	<b>Exp. Time (Total)/[Actual Dur.]</b>	<b>Orbit</b>	
	1		(3) V1369-CEN-2013	STIS/CCD, ACQ, 50CCD	MIRROR				1 Secs (1 Secs)		
									[==>]	[1]	
	2	(625971)	(3) V1369-CEN-2013	STIS/FUV-MAMA, ACCUM, 0.2X0.2	E140M 1425 A				800 Secs (800 Secs)		
									[==>]	[1]	
	<i>Comments: the input spectrum in the ETC is the stis/FUV/E140M spectrum of nova Del 2013 when at 11 mag. Cen 2013 and Del 2013 are two very alike noave in type (CO-WD) and spectral evolution. Cen is suppose d to be at the same mag in Dec 2014. Our first obs is in Feb 2015, when it will be even fainter.</i>										
	3	(626117)	(3) V1369-CEN-2013	STIS/NUV-MAMA, ACCUM, 0.2X0.2	E230M 1978 A				602 Secs (602 Secs)		
									[==>]	[1]	
	<i>Comments: the input spectrum in the ETC is the stis/NUV/E230M/1978 spectrum of nova Del 2013 when at 11 mag. Cen 2013 and Del 2013 are two very alike noave in type (CO-WD) and spectral evolution. Cen is supposed to be at the same mag in Dec 2014. Our first obs is in Feb 2015, when it will be even fainter.</i>										
	4	(626030)	(3) V1369-CEN-2013	STIS/NUV-MAMA, ACCUM, 0.2X0.2	E230M 2707 A				601 Secs (601 Secs)		
								[==>]	[1]		
<i>Comments: the input spectrum in the ETC is the stis/NUV/E230M/2070 spectrum of nova Del 2013 when at 11 mag. Cen 2013 and Del 2013 are two very alike noave in type (CO-WD) and spectral evolution. Cen is supposed to be at the same mag in Dec 2014. Our first obs is in Feb 2015, when it will be even fainter.</i>											

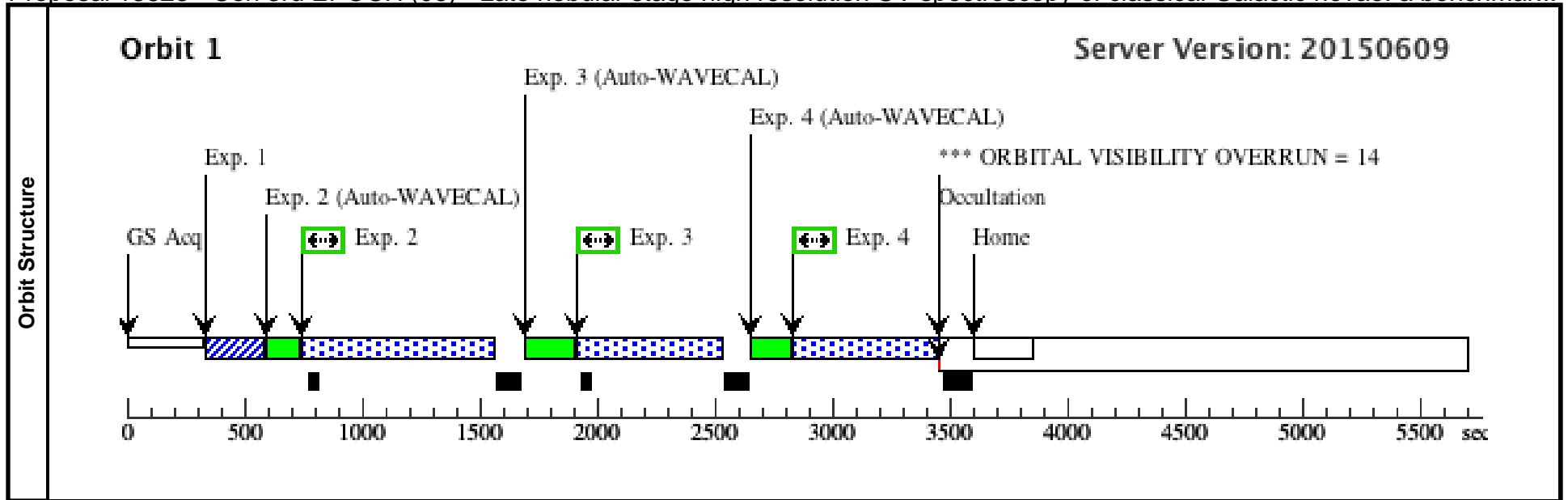

Proposal 13828 - Del 1st EPOCH (08) - Late nebular stage high resolution UV spectroscopy of classical Galactic novae: a benchmark ...

Fri Nov 20 02:07:35 GMT 2015

<b>Visit</b>	<b>Proposal 13828, Del 1st EPOCH (08), completed</b> <b>Diagnostic Status: Warning</b> Scientific Instruments: STIS/NUV-MAMA, STIS/CCD, STIS/FUV-MAMA Special Requirements: BETWEEN 03-MAY-2015:00:00:00 AND 18-MAY-2015:00:00:00									
	(Del 1st EPOCH (08)) Warning (Orbit Planner): ORBITAL VISIBILITY OVERRUN (Del 1st EPOCH (08)) Warning (Orbit Planner): ORBITAL VISIBILITY OVERRUN									
<b>Diagnosics</b>										
<b>Fixed Targets</b>	<b>#</b>	<b>Name</b>	<b>Target Coordinates</b>	<b>Targ. Coord. Corrections</b>	<b>Fluxes</b>	<b>Miscellaneous</b>				
	(2)	V339-DEL	RA: 20 23 30.6800 (305.8778333d) Dec: +20 46 3.80 (20.76772d) Equinox: J2000		V=13.2+/-0.5	Reference Frame: ICRS				
<i>Comments: This object was generated by the targetselector and retrieved from the SIMBAD database.</i>										
<b>Exposures</b>	<b>#</b>	<b>Label (ETC Run)</b>	<b>Target</b>	<b>Config,Mode,Aperture</b>	<b>Spectral Els.</b>	<b>Opt. Params.</b>	<b>Special Reqs.</b>	<b>Groups</b>	<b>Exp. Time (Total)/[Actual Dur.]</b>	<b>Orbit</b>
	1		(2) V339-DEL	STIS/CCD, ACQ, 50CCD	MIRROR				1 Secs (1 Secs)	
									[==>]	[1]
	2	(625971)	(2) V339-DEL	STIS/FUV-MAMA, ACCUM, 0.2X0.2	E140M 1425 A				2455 Secs (2455 Secs)	
									[==>]	[1]
	<i>Comments: the input spectrum in the ETC is the stis/FUV/E140M spectrum of nova Del 2013 when at 11 mag. Del is currently (Jul 24 2014) V~12.5 and will keep fading.</i>									
3	(626117)	(2) V339-DEL	STIS/NUV-MAMA, ACCUM, 0.2X0.2	E230M 1978 A				1328 Secs (1328 Secs)		
								[==>]	[2]	
<i>Comments: the input spectrum in the ETC simulation is nova Del observed with STIS (same setup) when at about V~11 mag. Now it is ~1.5 mag fainter and will keep fading.</i>										
4	(626030)	(2) V339-DEL	STIS/NUV-MAMA, ACCUM, 0.2X0.2	E230M 2707 A				1327 Secs (1327 Secs)		
								[==>]	[2]	
<i>Comments: the input spectrum in the ETC simulation is nova Del observed with STIS (same setup) when at about V~11 mag. Now it is ~1.5 mag fainter and will keep fading.</i>										

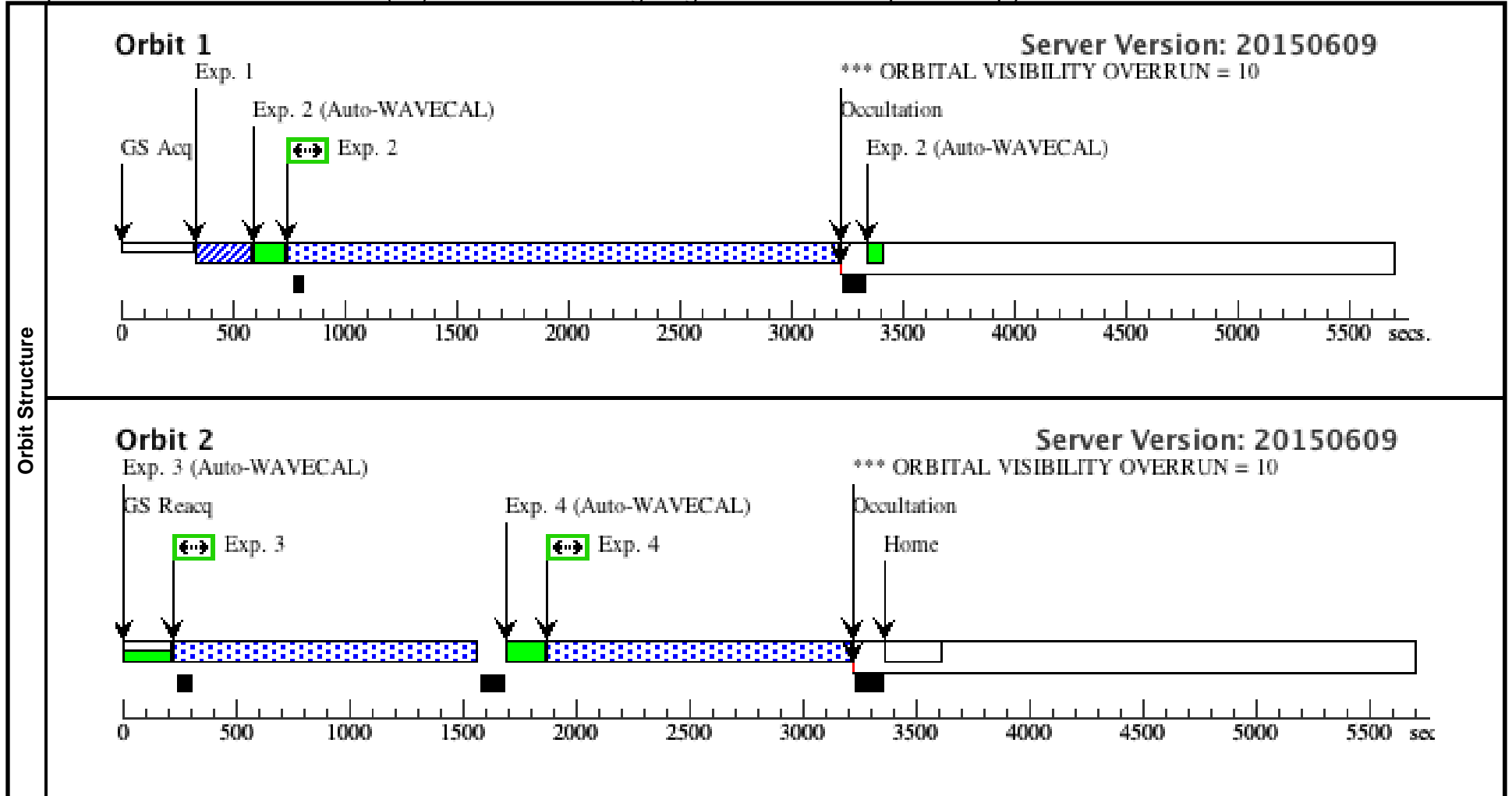

Proposal 13828 - Del 2nd EPOCH (09) - Late nebular stage high resolution UV spectroscopy of classical Galactic novae: a benchmark...

Fri Nov 20 02:07:35 GMT 2015

<b>Visit</b>	<b>Proposal 13828, Del 2nd EPOCH (09), failed</b> <b>Diagnostic Status: Warning</b> Scientific Instruments: STIS/NUV-MAMA, STIS/CCD, STIS/FUV-MAMA Special Requirements: BETWEEN 01-SEP-2015:00:00:00 AND 30-OCT-2015:00:00:00									
	(Del 2nd EPOCH (09)) Warning (Orbit Planner): ORBITAL VISIBILITY OVERRUN (Del 2nd EPOCH (09)) Warning (Orbit Planner): ORBITAL VISIBILITY OVERRUN									
<b>Diagnosics</b>										
<b>Fixed Targets</b>	<b>#</b>	<b>Name</b>	<b>Target Coordinates</b>	<b>Targ. Coord. Corrections</b>	<b>Fluxes</b>	<b>Miscellaneous</b>				
	(2)	V339-DEL	RA: 20 23 30.6800 (305.8778333d) Dec: +20 46 3.80 (20.76772d) Equinox: J2000		V=13.2+/-0.5	Reference Frame: ICRS				
<i>Comments: This object was generated by the targetselector and retrieved from the SIMBAD database.</i>										
<b>Exposures</b>	<b>#</b>	<b>Label (ETC Run)</b>	<b>Target</b>	<b>Config,Mode,Aperture</b>	<b>Spectral Els.</b>	<b>Opt. Params.</b>	<b>Special Reqs.</b>	<b>Groups</b>	<b>Exp. Time (Total)/[Actual Dur.]</b>	<b>Orbit</b>
	1		(2) V339-DEL	STIS/CCD, ACQ, 50CCD	MIRROR				1 Secs (1 Secs)	
									[==>]	[1]
	2	(625971)	(2) V339-DEL	STIS/FUV-MAMA, ACCUM, 0.2X0.2	E140M 1425 A				2455 Secs (2455 Secs)	
									[==>]	[1]
	<i>Comments: the input spectrum in the ETC is the stis/FUV/E140M spectrum of nova Del 2013 when at 11 mag. Del is currently (Jul 24 2014) V~12.5 and will keep fading.</i>									
3	(626117)	(2) V339-DEL	STIS/NUV-MAMA, ACCUM, 0.2X0.2	E230M 1978 A				1328 Secs (1328 Secs)		
								[==>]	[2]	
<i>Comments: the input spectrum in the ETC simulation is nova Del observed with STIS (same setup) when at about V~11 mag. Now it is ~1.5 mag fainter and will keep fading.</i>										
4	(626030)	(2) V339-DEL	STIS/NUV-MAMA, ACCUM, 0.2X0.2	E230M 2707 A				1327 Secs (1327 Secs)		
								[==>]	[2]	
<i>Comments: the input spectrum in the ETC simulation is nova Del observed with STIS (same setup) when at about V~11 mag. Now it is ~1.5 mag fainter and will keep fading.</i>										

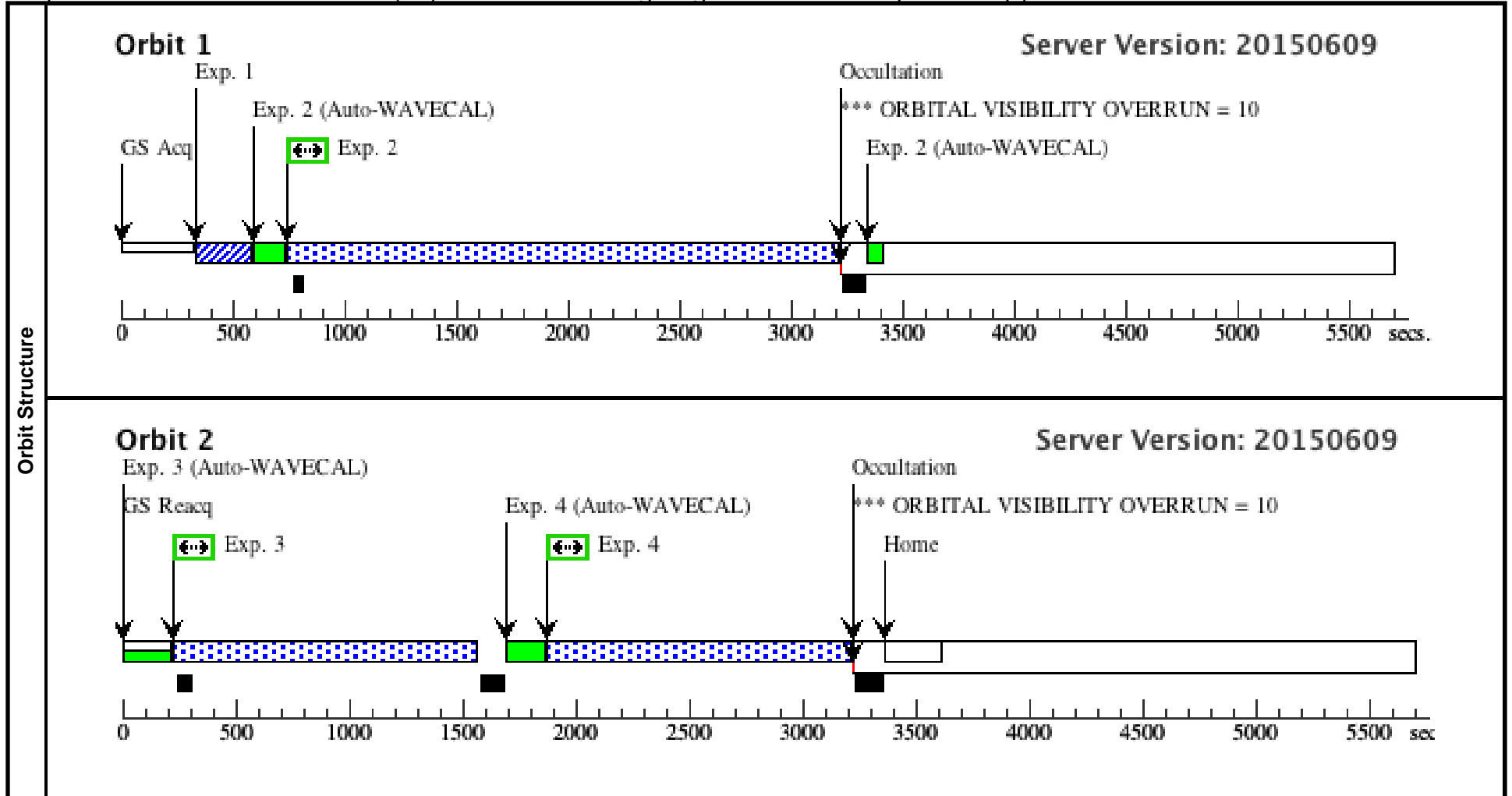

Proposal 13828 - Del 2nd EPOCH Repeat (59) - Late nebular stage high resolution UV spectroscopy of classical Galactic novae: a be...

Fri Nov 20 02:07:35 GMT 2015

<b>Visit</b>	<b>Proposal 13828, Del 2nd EPOCH Repeat (59)</b> <b>Diagnostic Status: Warning</b> Scientific Instruments: STIS/NUV-MAMA, STIS/CCD, STIS/FUV-MAMA Special Requirements: (none)									
	(Del 2nd EPOCH Repeat (59)) Warning (Orbit Planner): ORBITAL VISIBILITY OVERRUN (Del 2nd EPOCH Repeat (59)) Warning (Orbit Planner): ORBITAL VISIBILITY OVERRUN									
<b>Diagnosics</b>										
<b>Fixed Targets</b>	<b>#</b>	<b>Name</b>	<b>Target Coordinates</b>	<b>Targ. Coord. Corrections</b>	<b>Fluxes</b>	<b>Miscellaneous</b>				
	(2)	V339-DEL	RA: 20 23 30.6800 (305.8778333d) Dec: +20 46 3.80 (20.76772d) Equinox: J2000		V=13.2+/-0.5	Reference Frame: ICRS				
<i>Comments: This object was generated by the targetselector and retrieved from the SIMBAD database.</i>										
<b>Exposures</b>	<b>#</b>	<b>Label (ETC Run)</b>	<b>Target</b>	<b>Config,Mode,Aperture</b>	<b>Spectral Els.</b>	<b>Opt. Params.</b>	<b>Special Reqs.</b>	<b>Groups</b>	<b>Exp. Time (Total)/[Actual Dur.]</b>	<b>Orbit</b>
	1		(2) V339-DEL	STIS/CCD, ACQ, 50CCD	MIRROR				1 Secs (1 Secs)	
									[==>]	[1]
	2	(625971)	(2) V339-DEL	STIS/FUV-MAMA, ACCUM, 0.2X0.2	E140M 1425 A				2455 Secs (2455 Secs)	
									[==>]	[1]
	<i>Comments: the input spectrum in the ETC is the stis/FUV/E140M spectrum of nova Del 2013 when at 11 mag. Del is currently (Jul 24 2014) V~12.5 and will keep fading.</i>									
3	(626117)	(2) V339-DEL	STIS/NUV-MAMA, ACCUM, 0.2X0.2	E230M 1978 A				1328 Secs (1328 Secs)		
								[==>]	[2]	
<i>Comments: the input spectrum in the ETC simulation is nova Del observed with STIS (same setup) when at about V~11 mag. Now it is ~1.5 mag fainter and will keep fading.</i>										
4	(626030)	(2) V339-DEL	STIS/NUV-MAMA, ACCUM, 0.2X0.2	E230M 2707 A				1327 Secs (1327 Secs)		
								[==>]	[2]	
<i>Comments: the input spectrum in the ETC simulation is nova Del observed with STIS (same setup) when at about V~11 mag. Now it is ~1.5 mag fainter and will keep fading.</i>										

