



14602 - The Perseus Project: Probing Metal Mixing, Dust Destruction, and Kinematics in the Vertical Extension of the Perseus Arm

Cycle: 24, Proposal Category: GO

(UV Initiative)

(Availability Mode: SUPPORTED)

INVESTIGATORS

<i>Name</i>	<i>Institution</i>	<i>E-Mail</i>
Prof. Jay Christopher Howk (PI) (Contact)	University of Notre Dame	jhowk@nd.edu
Dr. Nicolas Lehner (CoI)	University of Notre Dame	nlehner@nd.edu
Dr. Andrew J. Fox (CoI) (ESA Member)	Space Telescope Science Institute - ESA	afox@stsci.edu
Prof. Todd M. Tripp (CoI)	University of Massachusetts - Amherst	tripp@astro.umass.edu
Dr. Felix J. Lockman (CoI)	Associated Universities, Inc.	jlockman@nrao.edu
Erin Boettcher (CoI)	University of Wisconsin - Madison	boettche@astro.wisc.edu

VISITS

<i>Visit</i>	<i>Targets used in Visit</i>	<i>Configurations used in Visit</i>	<i>Orbits Used</i>	<i>Last Orbit Planner Run</i>	<i>OP Current with Visit?</i>
01	(1) HD15137	STIS/CCD STIS/NUV-MAMA	1	16-Dec-2016 21:03:10.0	yes
02	(2) HD14633	STIS/CCD STIS/FUV-MAMA STIS/NUV-MAMA	2	16-Dec-2016 21:03:11.0	yes
03	(4) HD242926	STIS/CCD STIS/FUV-MAMA STIS/NUV-MAMA	3	16-Dec-2016 21:03:13.0	yes

<i>Visit</i>	<i>Targets used in Visit</i>	<i>Configurations used in Visit</i>	<i>Orbits Used</i>	<i>Last Orbit Planner Run</i>	<i>OP Current with Visit?</i>
04	(5) HD233622	STIS/CCD STIS/FUV-MAMA STIS/NUV-MAMA	3	16-Dec-2016 21:03:15.0	yes
05	(3) PG0122+214	STIS/CCD STIS/FUV-MAMA STIS/NUV-MAMA	4	16-Dec-2016 21:03:17.0	yes

13 Total Orbits Used

ABSTRACT

We propose to use high-resolution STIS absorption spectroscopy of bright stars to probe the vertical structure of gas in the Perseus arm of the Milky Way. We will target 5 stars in 2 vertical stripes, probing the high-z extension of the Perseus arm to $z \sim 1.7$ kpc. Our proposed observations will provide the first measurement of vertical abundance gradients in the gas of the Milky Way -- which will constrain the mixture of fountain-driven outflows compared with cooled gas from the metal-poor Galactic corona. We will quantify changes in the dust composition and kinematics with z -height in the Perseus arm, and we will quantify the relative masses of the cool, warm (neutral and ionized), and warm-hot phases of the ISM with height. Our proposed program will provide direct measurements of the vertical metal mixing scales in the Milky Way, and it will limit the degree to which the Milky Way is tapping its corona for new material for star formation, both important in the larger context of galaxy evolution.

OBSERVING DESCRIPTION

*Target selection and Experimental Design:

Our goal is to measure gas-phase abundances of volatile elements in the Perseus arm and its extension along two stripes oriented perpendicular to the plane. In particular, our aim is to measure the gas-phase column densities of Zn II, P II, and S II at differing heights in Perseus. These are all only mildly incorporated into dust grains if at all, so they provide a good measure of the metallicity of the gas. Zn II is the critical ion for several reasons: 1) it is very lightly depleted if at all (Jenkins 2009); 2) it is strong enough to be detected at low columns, and it is a doublet, allowing for saturation determinations and corrections at higher columns; 3) it (seems) not as susceptible to ionization issues as other ions (Sembach et al. 2000). Given its high ionization potential, S II can be contaminated by ionized gas, biasing metallicities (although it is an important tracer of the total ionized gas content and ionization level; Howk & Consiglio 2012, Howk et al. 2006). P II is weak and difficult to detect well. We will also assess the dust

depletion signature with height, comparing these volatiles with refractory elements (Mg II, Si II, Fe II, Cr II) and study the ionized gas content and kinematics (using S III, Al III, Si III, Si IV, C IV, N V and in some cases O VI from FUSE). While the dust depletion measures can be affected by ionization effects, the error involved is likely not great.

We identified at 2+ stars aligned within a few degrees in longitude in two stripes at longitudes where the Perseus arm is well-separated in velocity from local absorption (Kepner 1970). We feel it is critical to have at least two vertical samples in order to confirm any apparent metallicity gradients. We used MAST to search for O stars previously observed by UV spectrographs in order to identify stars that were within the brightness limits for high-resolution STIS spectroscopy, whose spectra were not too complicated, and that also resided well behind the Perseus arm. This included verifying that they were not too bright for STIS; in a few cases we make use of the 0.025 arcsec ("Jenkins") slits due to the brightness (but these have the advantage of providing $R \sim 200,000$). In all cases, UV flux measurements were available through IUE or archival HST data. We paid careful attention to the existing HST data and preferred stars for which a significant fraction of the data is already in hand (e.g., the star HD 15137 which already has exquisite E140H data at $R \sim 200,000$ and $S/N > 40$). When HST data were available, we confirmed that Perseus arm absorption is seen in the existing spectra, even if they did not meet all of our S/N goals.

*Observational Design:

Our limiting goal is to measure the column densities of Zn II (2026/2062) and S II (1250/1253/1259) at $>7-10$ sigma to provide robust measures of any vertical variations. The required sensitivity and the need to accurately separate local from Perseus absorption push us in most cases to the E140H/E230H gratings. In the NUV, the trade-off between the E230H and E230M gratings is clear: the limiting column density scales inversely with resolution for unresolved (E230M) lines, and we can do $>50\%$ better in comparable time by using the E230H grating. For the high-latitude stars, the existing E140M observations demonstrate that grating can provide good measurements with more exposure time.

To achieve our goals at Zn II, we aim for $S/N(2026) \sim 25$ with the E230H grating. We are not concerned only with detecting Zn II along the higher-latitude sight lines, but also with having good enough S/N to fit simultaneously the 2026 and 2062 profiles for the low-latitude sight lines to assess and account for potential saturation. For the S II triplet we aim for $S/N(1250) \sim 25$ with the E140H gratings, $S/N(1250) > 30$ with E140M. In all cases we use either the 0.06"/0.09" or 0.025" slits. These provide a significantly better-behaved LSF compared with the 0.2" apertures (which have significant broad wings resulting from the PSF of the telescope). This is important in our case since we will be using detailed profile fitting techniques to measure the column densities and separate components from one another. We have estimated the required exposure times for each star using the online ETC, accounting for data that are already in hand. We note that this program cannot be done using COS. There are several COS

sight lines in this direction (e.g., Lehner & Howk 2010); however, the resolution of COS is insufficient for deriving precise ionic column densities and accurately separating Local from Perseus arm gas.

*Abundance determinations:

We will use our observations of low-ion absorption from Zn II, S II, and P II to determine absolute metallicities of Perseus gas by comparison with H I 21-cm observations. Zn II is critical, as it does not suffer from the same potential ionization issues as S II. However, S II is required to understand the ionization and total gas column (H I+H II; Howk et al. 2006). We request coordinated time on the 100-m Green Bank Telescope to acquire the best measures of H I column densities in these directions. We have experience using the GBT to follow-up other recent HST programs. We will also make use of the newly-released Effelsberg H I Survey (EBHIS; Winkel et al. 2016) for mapping the H I over larger scales. Both the GBT and Effelsberg have a 9' primary beam; the GBT has slightly better control for stray radiation in its unblocked beam. While the radio and UV observations probe different beams through the ISM, Wakker et al. (2012) have shown that GBT 21-cm emission and UV Ly-alpha absorption measurements of N(H I) give very good agreement, with a typical uncertainty associated with this mismatch of order ~6% in N(H I), well below our requirements. All of our low-latitude targets have available FUSE data for deriving H₂ to complete the H census required for low ion abundance determinations. We will also use the EBHIS to understand the large-scale structure of the Perseus arm in the directions of our vertical slices. We also note that we will be able to pursue the same program for the Outer Arm toward PG0122+214 (ID#3) using the archival sight line to HD 232522 [(l,b)=(130.7, -6.7)], d=6.1 kpc]. PG0122+214 intercepts the Outer Arm extension at z~-4.3 kpc; although it isn't yet clear if it will be detected at that height, it is seen at z~3.3 kpc toward H1821+643 (Tripp & Song 2012).

All our stars in our sample have a visibility between about 54-58 minutes. Including overheads due to target acquisition/peak-up and instrument setting changes (when applicable), we estimated using the online STIS ETC and observed UV fluxes (available at MAST for all the stars) that 1 to 2 orbits per setting depending on the UV flux level will provide the minimum S/N >= 25 per resolution element near SII 1250 and/or ZnII 2026, 2062 to model these lines at the required 7-10 sigma level. For brighter disk targets, we use separate set-ups to cover C IV 1548, 1550 and Si II 1808 (these ions are covered for the higher-latitude stars by existing data).

Visit	Proposal 14602, HD15137 (01), implementation				
	Diagnostic Status: No Diagnostics				
	Scientific Instruments: STIS/NUV-MAMA, STIS/CCD				
	Special Requirements: (none)				

Fixed Targets	#	Name	Target Coordinates	Targ. Coord. Corrections	Fluxes	Miscellaneous
	(1)	HD15137	RA: 02 27 59.8117 (36.9992154d) Dec: +52 32 57.59 (52.54933d) Equinox: J2000	Proper Motion RA: 1.02 mas/yr Proper Motion Dec: -4.54 mas/yr Parallax: 0" Epoch of Position: 1991.25	V=7.86 STIS FUV[1250]=2.0e-11, NUV[2025]=1.0e-11	Reference Frame: ICRS
	<i>Comments: This object was generated by the targetselector and retrieved from the SIMBAD database, which agree with Hipparcos positions. Proper motions from Hipparcos.</i>					
	**Stellar parameters: *Sp Type: O9.5 II-III [Sota+ 2011] *BV = 7.92, 7.86; J=7.796 *E(B-V) = 0.31 [DS94 for O9.5 II-III, B-V=0.01]; = 0.24 [Bowen+ (2008) for O9.5 II-III]					

Exposures	#	Label (ETC Run)	Target	Config,Mode,Aperture	Spectral Els.	Opt. Params.	Special Reqs.	Groups	Exp. Time (Total)/[Actual Dur.]	Orbit
	1	ACQ (STIS.ta.827 364)	(1) HD15137	STIS/CCD, ACQ, F25ND3	MIRROR	ACQTYPE=POINT			0.6 Secs (0.6 Secs) [==>]	[1]
	2	PEAK/0.09 (STIS.sp.82 7399)	(1) HD15137	STIS/CCD, ACQ/PEAK, 0.2X0.09	G230LB 2375 A				2.0 Secs (2 Secs) [==>]	[1]
	3	PEAK/0.03 (STIS.sp.82 7397)	(1) HD15137	STIS/CCD, ACQ/PEAK, 0.1X0.03	G230LB 2375 A				3.0 Secs (3 Secs) [==>]	[1]
	4	E230H (STIS.sp.82 7417)	(1) HD15137	STIS/NUV-MAMA, ACCUM, 0.1X0.03	E230H 2113 A				1525 Secs (1536 Secs) [==>1536.0 Secs]	[1]

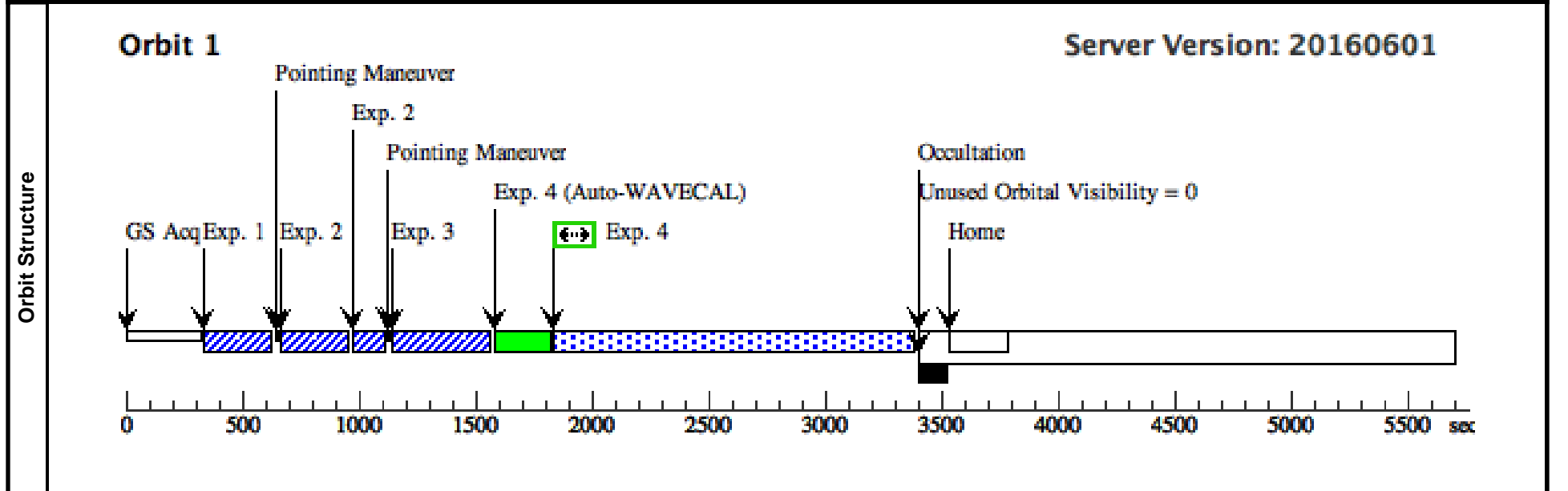

Visit	Proposal 14602, HD14633 (02), implementation Diagnostic Status: No Diagnostics Scientific Instruments: STIS/NUV-MAMA, STIS/CCD, STIS/FUV-MAMA Special Requirements: (none)												
	Fixed Targets	<table border="1"> <thead> <tr> <th>#</th> <th>Name</th> <th>Target Coordinates</th> <th>Targ. Coord. Corrections</th> <th>Fluxes</th> <th>Miscellaneous</th> </tr> </thead> <tbody> <tr> <td>(2)</td> <td>HD14633</td> <td> RA: 02 22 54.2828 (35.7261783d) Dec: +41 28 47.73 (41.47993d) Equinox: J2000 </td> <td> Proper Motion RA: 0.19 mas/yr Proper Motion Dec: -6.24 mas/yr Epoch of Position: 1991.25 </td> <td> V=7.47 IUE FUV[1250]=1.9e-10, NUV[2025]=3.8e-11 </td> <td>Reference Frame: ICRS</td> </tr> </tbody> </table> <p><i>Comments: This object was generated by the target selector and retrieved from the SIMBAD database, which agree with Hipparcos positions. Proper motions from Hipparcos.</i></p> <p><i>**Stellar parameters: Sp Type: ON8.5 V [Sota+ 2011] B,V = 7.26, 7.47; J=7.922 E(B-V) = 0.1 [Diplas & Savage 1994 for O8.0 Vn]</i></p> <p><i>The BOT provides a global count rate warning on the target HD 14633 . Detailed calculations with the ETC using measured UV fluxes from this object (IUE + large aperture) do not give cause for concern.</i></p> <p><i>The ETC calculations in question are: STIS.sp.827679, STIS.sp.827696, STIS.sp.827693.</i></p> <p><i>Some warnings are thrown about the object's brightness if it is irregularly variable. This source seems to be quite stable, with UV measurements over the past 30 years:</i></p> <p>2415A: IUE 1980/03/03 4.2e-11 IUE 1980/08/28 4.2e-11</p> <p>2025A: IUE 1980/03/03 6.6e-11 IUE 1980/08/28 6.6e-11</p> <p>1360A: IUE 1980/03/03 1.7e-10 IUE 1980/08/28 1.7e-10 TUES 1996/12/02 1.6e-10</p> <p>1148A: TUES 1996/12/02 2.0e-10 BEFS 1993/09/18 2.1e-10</p> <p>1046A: TUES 1996/12/02 2.6e-10 FUSE 2003/12/03 2.5e-10</p>	#	Name	Target Coordinates	Targ. Coord. Corrections	Fluxes	Miscellaneous	(2)	HD14633	RA: 02 22 54.2828 (35.7261783d) Dec: +41 28 47.73 (41.47993d) Equinox: J2000	Proper Motion RA: 0.19 mas/yr Proper Motion Dec: -6.24 mas/yr Epoch of Position: 1991.25	V=7.47 IUE FUV[1250]=1.9e-10, NUV[2025]=3.8e-11
#	Name	Target Coordinates	Targ. Coord. Corrections	Fluxes	Miscellaneous								
(2)	HD14633	RA: 02 22 54.2828 (35.7261783d) Dec: +41 28 47.73 (41.47993d) Equinox: J2000	Proper Motion RA: 0.19 mas/yr Proper Motion Dec: -6.24 mas/yr Epoch of Position: 1991.25	V=7.47 IUE FUV[1250]=1.9e-10, NUV[2025]=3.8e-11	Reference Frame: ICRS								

Proposal 14602 - HD14633 (02) - The Perseus Project: Probing Metal Mixing, Dust Destruction, and Kinematics in the Vertical Extensi...

Exposures	#	Label (ETC Run)	Target	Config,Mode,Aperture	Spectral Els.	Opt. Params.	Special Reqs.	Groups	Exp. Time (Total)/[Actual Dur.]	Orbit
	1	ACQ (STIS.sp.82 7625)	(2) HD14633	STIS/CCD, ACQ, F25ND3	MIRROR	ACQTYPE=POINT			1.0 Secs (1 Secs) [==>]	[1]
	2	PEAK/0.09 (STIS.sp.82 7628)	(2) HD14633	STIS/CCD, ACQ/PEAK, 0.2X0.09	G230LB 2375 A				1.0 Secs (1 Secs) [==>]	[1]
	3	PEAK/0.03 (STIS.sp.82 7625)	(2) HD14633	STIS/CCD, ACQ/PEAK, 0.1X0.03	G230LB 2375 A				1.0 Secs (1 Secs) [==>]	[1]
	4	E230H (STIS.sp.82 7930)	(2) HD14633	STIS/NUV-MAMA, ACCUM, 0.1X0.03	E230H 2113 A				900 Secs (900 Secs) [==>]	[1]
	5	E230H (STIS.sp.82 7696)	(2) HD14633	STIS/NUV-MAMA, ACCUM, 0.1X0.03	E230H 1813 A				200 Secs (200 Secs) [==>]	[1]
	6	E230H (STIS.sp.82 7696)	(2) HD14633	STIS/NUV-MAMA, ACCUM, 0.1X0.03	E230H 1813 A				700 Secs (697 Secs) [==>697.0 Secs]	[2]
	7	E140H (STIS.sp.82 7693)	(2) HD14633	STIS/FUV-MAMA, ACCUM, 0.1X0.03	E140H 1234 A				900 Secs (897 Secs) [==>897.0 Secs]	[2]
	8	E140H (STIS.sp.82 7679)	(2) HD14633	STIS/FUV-MAMA, ACCUM, 0.1X0.03	E140H 1489 A				600 Secs (597 Secs) [==>597.0 Secs]	[2]

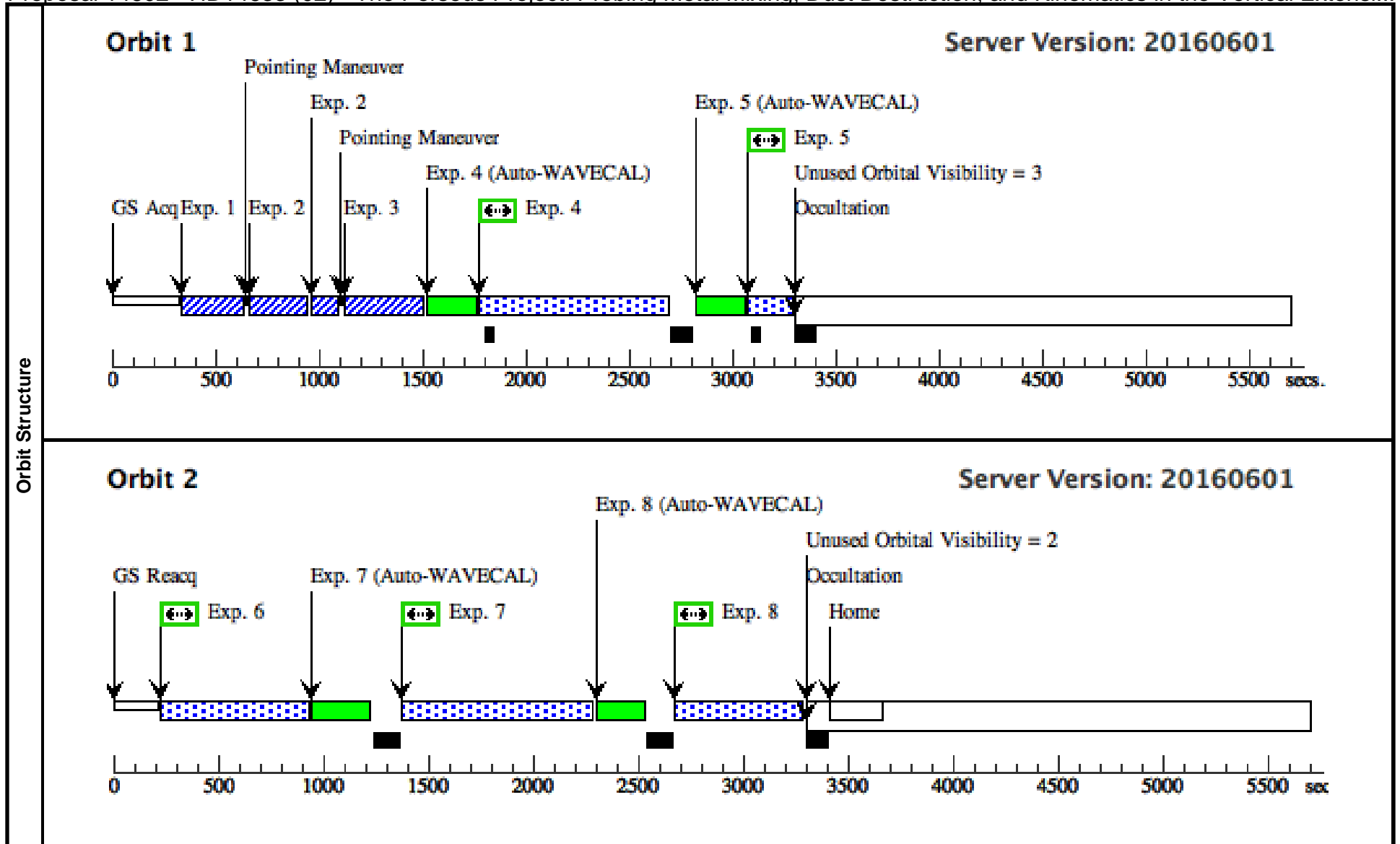

Proposal 14602 - HD242926 (03) - The Perseus Project: Probing Metal Mixing, Dust Destruction, and Kinematics in the Vertical Exten...

Sat Dec 17 02:03:18 GMT 2016

Visit	Proposal 14602, HD242926 (03), implementation Diagnostic Status: No Diagnostics Scientific Instruments: STIS/NUV-MAMA, STIS/CCD, STIS/FUV-MAMA Special Requirements: (none)																											
	Fixed Targets	<table border="1"> <thead> <tr> <th>#</th> <th>Name</th> <th>Target Coordinates</th> <th>Targ. Coord. Corrections</th> <th>Fluxes</th> <th>Miscellaneous</th> </tr> </thead> <tbody> <tr> <td>(4)</td> <td>HD242926</td> <td>RA: 05 22 40.0984 (80.6670767d) Dec: +33 19 9.37 (33.31927d) Equinox: J2000</td> <td></td> <td>V=9.4 IUE FUV[1250]=2.6e-12, NUV[2025]=1.2e-12</td> <td>Reference Frame: ICRS</td> </tr> <tr> <td colspan="6"><i>Comments: This object was generated by the targetselector and retrieved from the SIMBAD database.</i></td> </tr> </tbody> </table>										#	Name	Target Coordinates	Targ. Coord. Corrections	Fluxes	Miscellaneous	(4)	HD242926	RA: 05 22 40.0984 (80.6670767d) Dec: +33 19 9.37 (33.31927d) Equinox: J2000		V=9.4 IUE FUV[1250]=2.6e-12, NUV[2025]=1.2e-12	Reference Frame: ICRS	<i>Comments: This object was generated by the targetselector and retrieved from the SIMBAD database.</i>				
#	Name	Target Coordinates	Targ. Coord. Corrections	Fluxes	Miscellaneous																							
(4)	HD242926	RA: 05 22 40.0984 (80.6670767d) Dec: +33 19 9.37 (33.31927d) Equinox: J2000		V=9.4 IUE FUV[1250]=2.6e-12, NUV[2025]=1.2e-12	Reference Frame: ICRS																							
<i>Comments: This object was generated by the targetselector and retrieved from the SIMBAD database.</i>																												
Exposures	#	Label (ETC Run)	Target	Config,Mode,Aperture	Spectral Els.	Opt. Params.	Special Reqs.	Groups	Exp. Time (Total)/[Actual Dur.]	Orbit																		
	1	ACQ (STIS.ta.827 391)	(4) HD242926	STIS/CCD, ACQ, F28X500II	MIRROR	ACQTYPE=POINT			1 Secs (1 Secs) [==>]	[1]																		
	2	PEAK/0.09 (STIS.sp.82 7705)	(4) HD242926	STIS/CCD, ACQ/PEAK, 0.2X0.09	G230LB 2375 A				5 Secs (5 Secs) [==>]	[1]																		
	3	E230H (STIS.sp.82 7853)	(4) HD242926	STIS/NUV-MAMA, ACCUM, 0.2X0.09	E230H 1963 A				1800 Secs (1826 Secs) [==>1826.0 Secs]	[1]																		
	4	E230H (STIS.sp.82 7853)	(4) HD242926	STIS/NUV-MAMA, ACCUM, 0.2X0.09	E230H 1963 A				1500 Secs (1500 Secs) [==>]	[2]																		
	5	E230H (STIS.sp.82 7853)	(4) HD242926	STIS/NUV-MAMA, ACCUM, 0.2X0.09	E230H 1963 A				1250 Secs (1250 Secs) [==>]	[2]																		
	6	E140H (STIS.sp.82 7851)	(4) HD242926	STIS/FUV-MAMA, ACCUM, 0.2X0.09	E140H 1234 A				1500 Secs (1500 Secs) [==>]	[3]																		
	7	E140H (STIS.sp.82 7851)	(4) HD242926	STIS/FUV-MAMA, ACCUM, 0.2X0.09	E140H 1234 A				1350 Secs (1350 Secs) [==>]	[3]																		

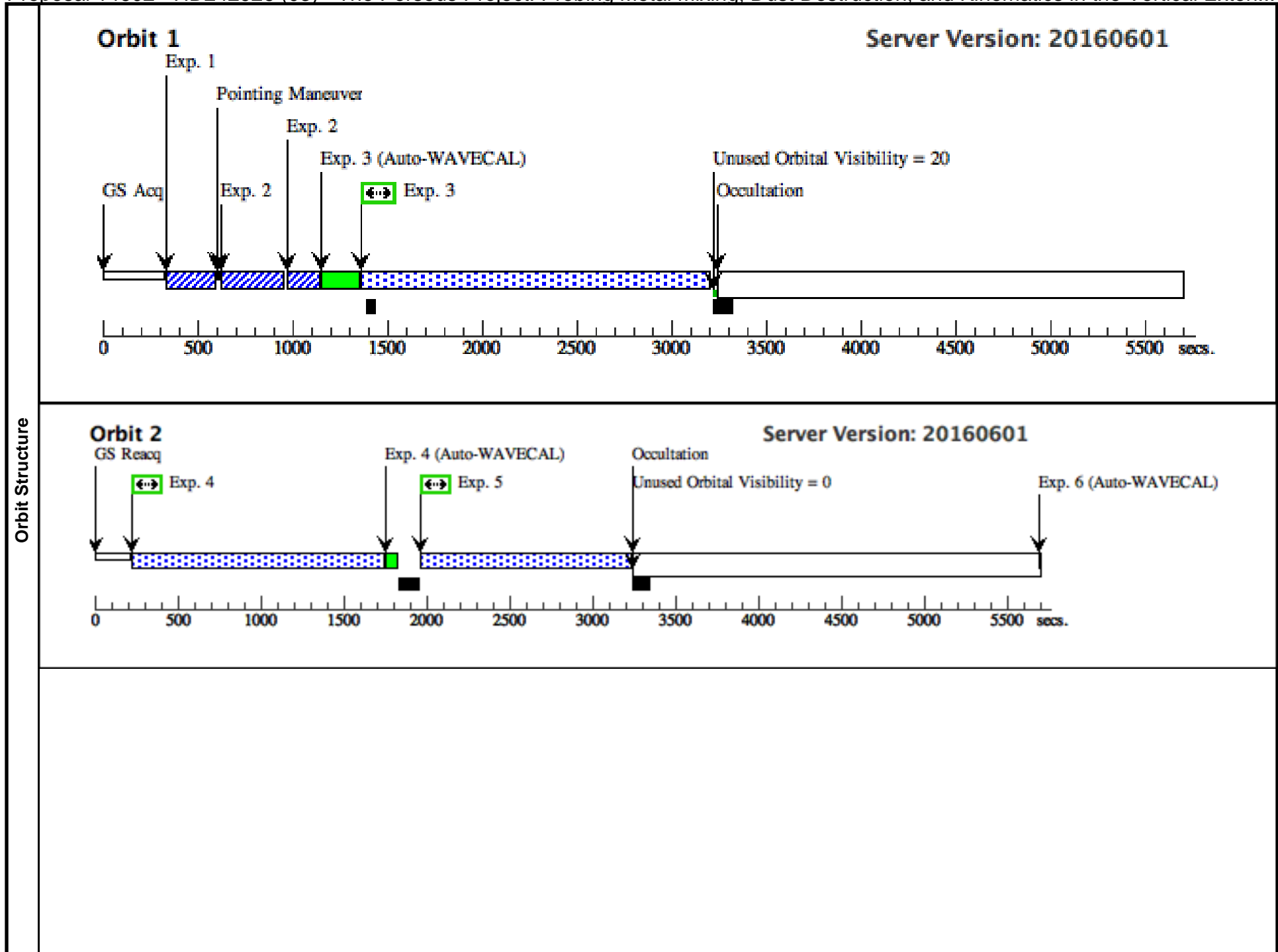

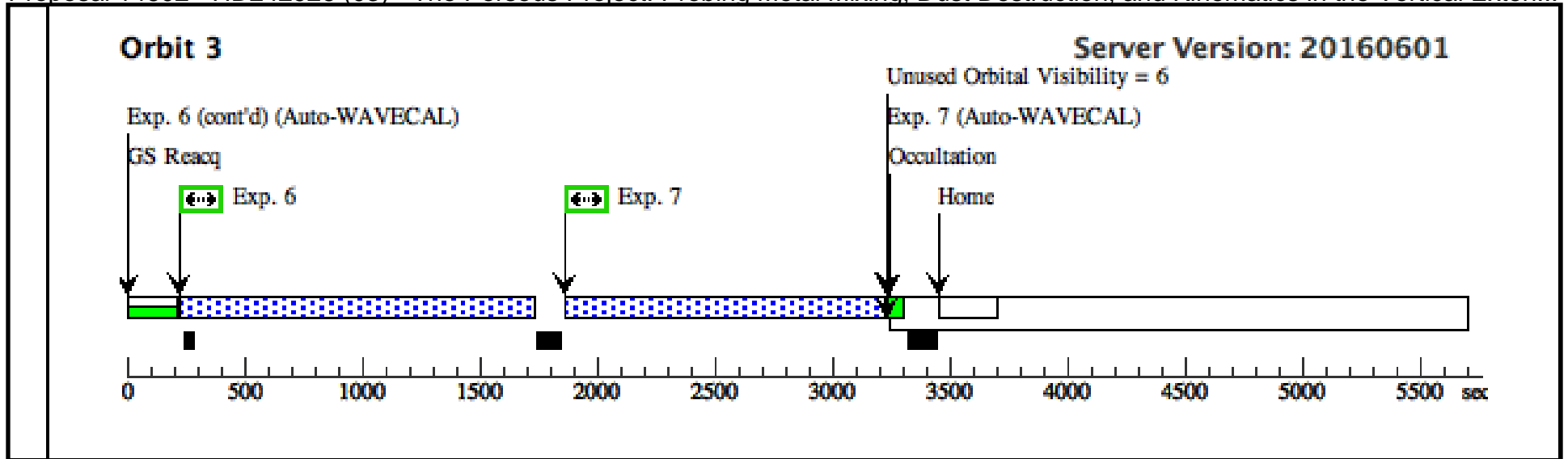

Proposal 14602 - HD233622 (04) - The Perseus Project: Probing Metal Mixing, Dust Destruction, and Kinematics in the Vertical Exten...

Sat Dec 17 02:03:18 GMT 2016

Visit	Proposal 14602, HD233622 (04), implementation Diagnostic Status: No Diagnostics Scientific Instruments: STIS/NUV-MAMA, STIS/CCD, STIS/FUV-MAMA Special Requirements: (none)									
	Fixed Targets	#	Name	Target Coordinates	Targ. Coord. Corrections	Fluxes	Miscellaneous			
	(5)	HD233622	RA: 09 21 33.6007 (140.3900029d) Dec: +50 05 56.36 (50.09899d) Equinox: J2000		V=9.91 STIS FUV=6.0e-12, NUV_est=2.0e-12	Reference Frame: ICRS				
	<i>Comments: This object was generated by the targetselector and retrieved from the SIMBAD database.</i>									
Exposures	#	Label (ETC Run)	Target	Config,Mode,Aperture	Spectral Els.	Opt. Params.	Special Reqs.	Groups	Exp. Time (Total)/[Actual Dur.]	Orbit
	1	ACQ (STIS.ta.827 863)	(5) HD233622	STIS/CCD, ACQ, F28X500II	MIRROR	ACQTYPE=POINT			2 Secs (2 Secs) [==>]	[1]
	2	PEAK/0.06 (STIS.sp.82 7705)	(5) HD233622	STIS/CCD, ACQ/PEAK, 0.2X0.06	G230LB 2375 A				10 Secs (10 Secs) [==>]	[1]
	3	E140H1 (STIS.sp.84 4876)	(5) HD233622	STIS/FUV-MAMA, ACCUM, 0.2X0.09	E140H 1234 A				1880 Secs (1880 Secs) [==>]	[1]
	4	E140H2 (STIS.sp.84 4880)	(5) HD233622	STIS/FUV-MAMA, ACCUM, 0.2X0.09	E140H 1489 A				1450 Secs (1428 Secs) [==>1428.0 Secs]	[2]
	5	E140H3 (STIS.sp.84 5012)	(5) HD233622	STIS/FUV-MAMA, ACCUM, 0.2X0.09	E140H 1562 A				1400 Secs (1378 Secs) [==>1378.0 Secs]	[2]
	6	E230H (STIS.sp.84 5010)	(5) HD233622	STIS/NUV-MAMA, ACCUM, 0.2X0.09	E230H 1963 A				1300 Secs (1357 Secs) [==>1357.0 Secs]	[3]
	7	E230H (STIS.sp.84 5010)	(5) HD233622	STIS/NUV-MAMA, ACCUM, 0.2X0.09	E230H 1963 A				1600 Secs (1657 Secs) [==>1657.0 Secs]	[3]

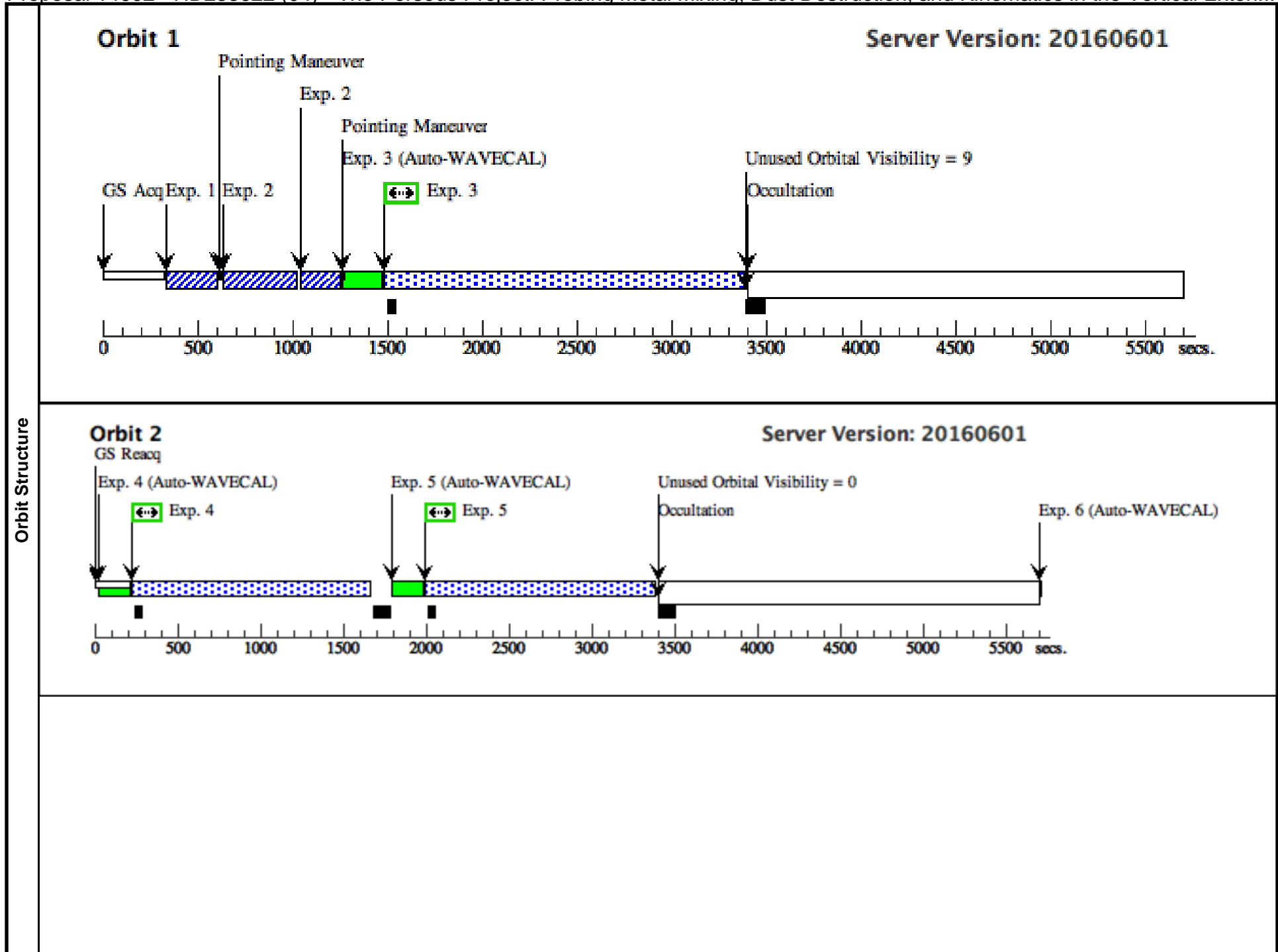

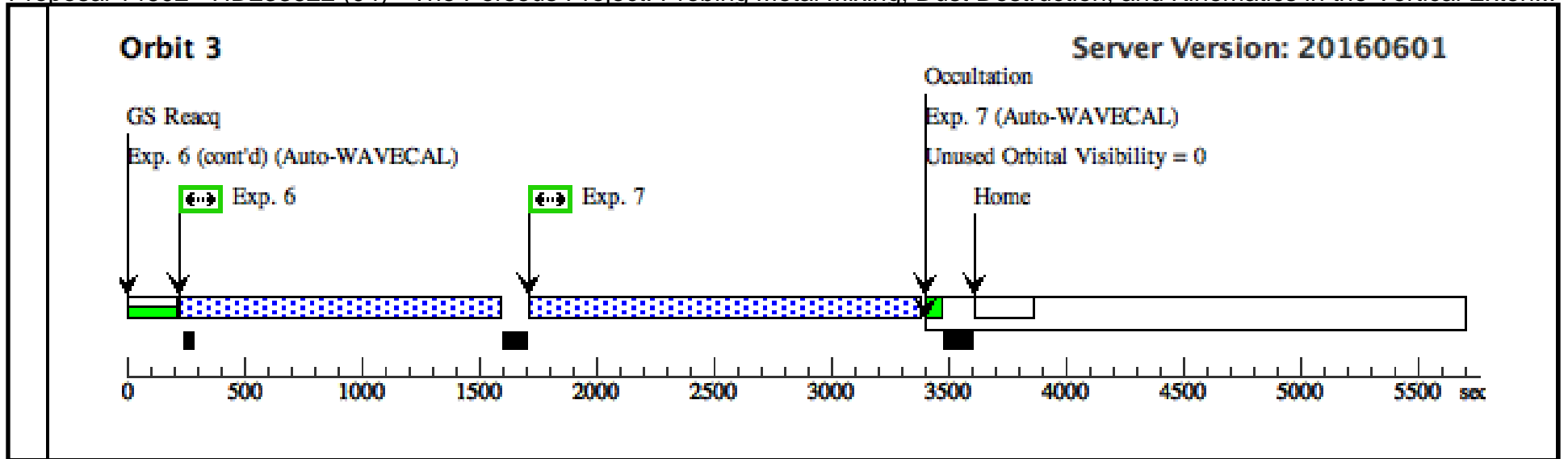

Proposal 14602 - PG0122+214 (05) - The Perseus Project: Probing Metal Mixing, Dust Destruction, and Kinematics in the Vertical Ext...

Sat Dec 17 02:03:18 GMT 2016

Visit	Proposal 14602, PG0122+214 (05), implementation Diagnostic Status: No Diagnostics Scientific Instruments: STIS/NUV-MAMA, STIS/CCD, STIS/FUV-MAMA Special Requirements: (none)									
	Fixed Targets	# Name Target Coordinates Targ. Coord. Corrections Fluxes Miscellaneous (3) PG0122+214 RA: 01 25 29.5200 (21.3730000d) Dec: +21 36 31.00 (21.60861d) Equinox: J2000 <i>Comments: This object was generated by the targetselector and retrieved from the SIMBAD database.</i>								
Exposures	#	Label (ETC Run)	Target	Config,Mode,Aperture	Spectral Els.	Opt. Params.	Special Reqs.	Groups	Exp. Time (Total)/[Actual Dur.]	Orbit
	1	ACQ (STIS.ta.827 996)	(3) PG0122+214	STIS/CCD, ACQ, F28X500II	MIRROR	ACQTYPE=POINT			2 Secs (2 Secs) [==>]	[1]
	2	PEAK/0.06 (STIS.sp.82 8006)	(3) PG0122+214	STIS/CCD, ACQ/PEAK, 0.2X0.06	G230LB 2375 A				10 Secs (10 Secs) [==>]	[1]
	3	E140M (STIS.sp.82 8011)	(3) PG0122+214	STIS/FUV-MAMA, ACCUM, 0.2X0.06	E140M 1425 A				1725 Secs (1725 Secs) [==>]	[1]
	4	E140M (STIS.sp.82 8011)	(3) PG0122+214	STIS/FUV-MAMA, ACCUM, 0.2X0.06	E140M 1425 A				1250 Secs (1255 Secs) [==>1255.0 Secs]	[2]
	5	E230H (STIS.sp.82 8013)	(3) PG0122+214	STIS/NUV-MAMA, ACCUM, 0.2X0.09	E230H 1963 A				1230 Secs (1235 Secs) [==>1235.0 Secs]	[2]
	6	E230H (STIS.sp.82 8013)	(3) PG0122+214	STIS/NUV-MAMA, ACCUM, 0.2X0.09	E230H 1963 A				1400 Secs (1413 Secs) [==>1413.0 Secs]	[3]
	7	E230H (STIS.sp.82 8013)	(3) PG0122+214	STIS/NUV-MAMA, ACCUM, 0.2X0.09	E230H 1963 A				1300 Secs (1313 Secs) [==>1313.0 Secs]	[3]
	8	E230H (STIS.sp.82 8013)	(3) PG0122+214	STIS/NUV-MAMA, ACCUM, 0.2X0.09	E230H 1963 A				1300 Secs (1313 Secs) [==>1313.0 Secs]	[4]
	9	E230H (STIS.sp.82 8013)	(3) PG0122+214	STIS/NUV-MAMA, ACCUM, 0.2X0.09	E230H 1963 A				1400 Secs (1413 Secs) [==>1413.0 Secs]	[4]

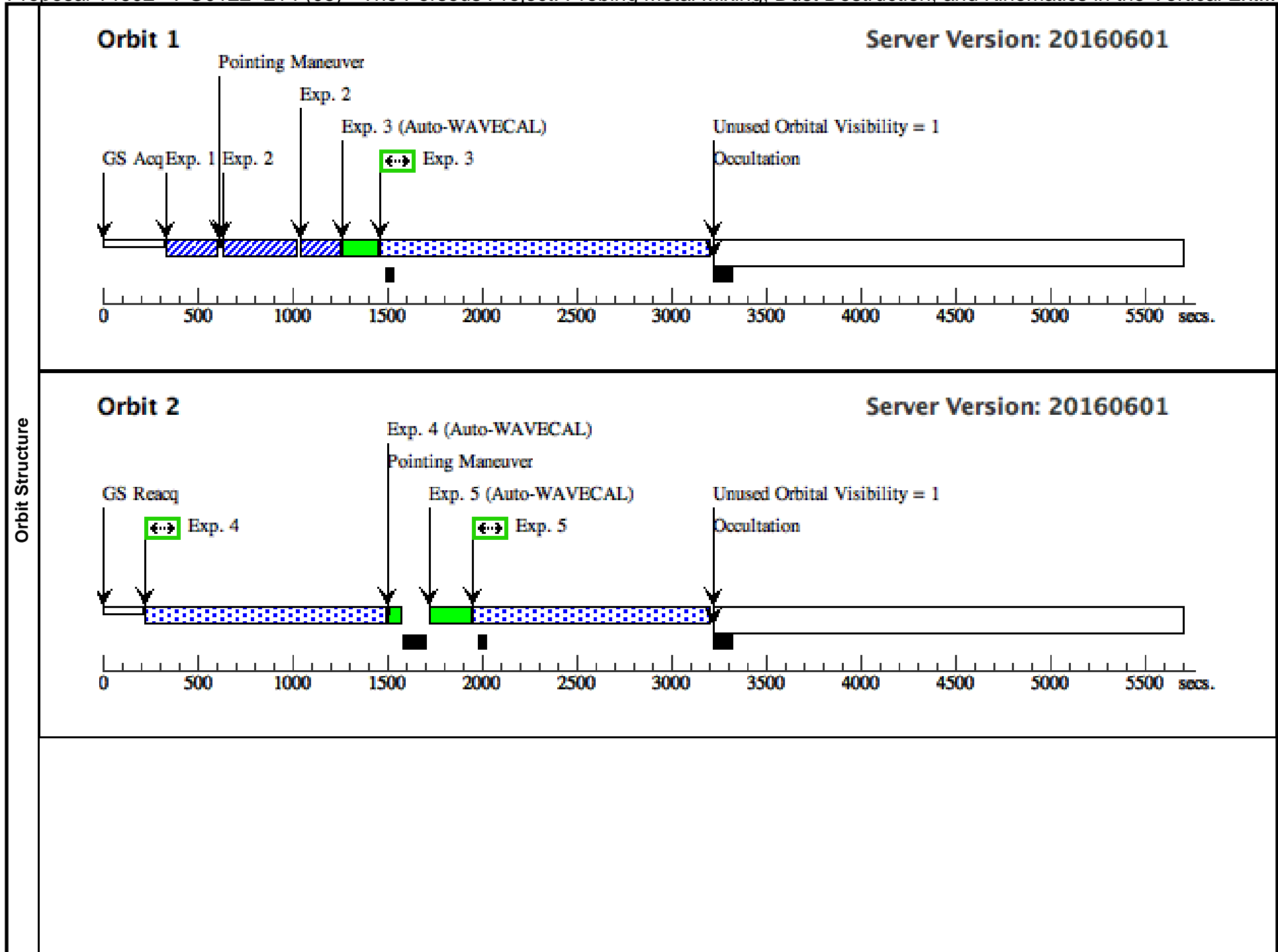

Orbit 3

Server Version: 20160601

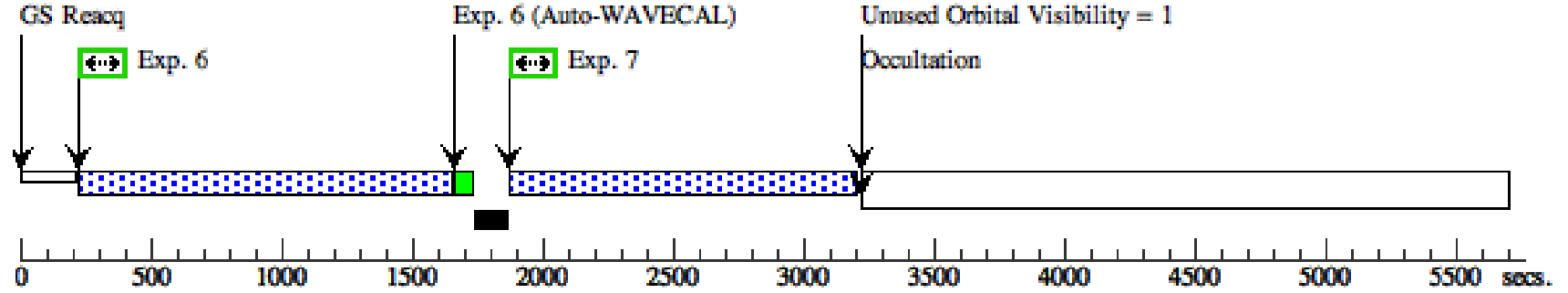

Orbit 4

Server Version: 20160601

