



## 14631 - Resolving the Nuclear Structure of the Canonical Radio Galaxy M87

Cycle: 24, Proposal Category: GO

(UV Initiative)

(Availability Mode: SUPPORTED)

### INVESTIGATORS

<i>Name</i>	<i>Institution</i>	<i>E-Mail</i>
<b>Dr. Charles W. Danforth (PI) (Contact)</b>	<b>University of Colorado at Boulder</b>	<b>danforth@colorado.edu</b>
Prof. John Thomas Stocke (CoI)	University of Colorado at Boulder	stocke@casa.colorado.edu
Prof. Mitchell C. Begelman (CoI)	University of Colorado at Boulder	mitch@jila.colorado.edu
Dr. Kevin France (CoI)	University of Colorado at Boulder	kevin.france@colorado.edu
Prof. Eric S. Perlman (CoI)	Florida Institute of Technology	eperlman@fit.edu

### VISITS

<i>Visit</i>	<i>Targets used in Visit</i>	<i>Configurations used in Visit</i>	<i>Orbits Used</i>	<i>Last Orbit Planner Run</i>	<i>OP Current with Visit?</i>
01	(1) M-87	COS/FUV	1	27-Mar-2017 21:00:25.0	yes
05	(1) M-87	COS/FUV	1	27-Mar-2017 21:00:26.0	yes
02	(1) M-87	STIS/CCD STIS/FUV-MAMA	4	27-Mar-2017 21:00:29.0	yes
03	(1) M-87	COS/FUV	1	27-Mar-2017 21:00:30.0	yes
04	(1) M-87	STIS/CCD STIS/FUV-MAMA	4	27-Mar-2017 21:00:32.0	yes

11 Total Orbits Used

## **ABSTRACT**

The nearby galaxy M87 is the prototype for low-power radio-loud FR1-type AGN, the parent population of BL Lac type blazars. Despite its proximity, brightness, and nearly a century of observations, the physical picture of how the AGN emission is fueled and what is causing the bright and variable emission in the core of M87 is still mysterious. Recent COS observations show a complex and variable line profile and weak UV continuum with hints of spatial structure (Danforth et al. 2016). Consistent with recent X-ray observations, we find little accreting gas inside the Bondi radius. We propose to resolve and precisely locate the ionizing continuum and Ly alpha line-emitting structures with long-slit far-UV STIS spectra of the nucleus. These observations will also allow us to confirm (or not) the density-bounded nature of the line emission. Along with the spatially-resolved spectroscopy, we will use multi-epoch, high-S/N COS aperture spectroscopy to address the mystery of what powers this common yet poorly-understood class of active galaxies.

## **OBSERVING DESCRIPTION**

We request two visits of five orbits each to observe the nucleus of M87. The two visits will be planned such that the STIS slit is placed along the axis of the relativistic jet during one visit and perpendicular to it on the other. Four orbits of each five-orbit visit will be devoted to spatially-resolved STIS/G140M spectroscopy with the 52x0.2" slit. The final orbit for each case will acquire sensitive COS/G130M data to obtain high-S/N measurements of the Ly $\alpha$  profile and wings as well as metal-line emission.

We base our exposure time requirements on the lowest flux component of the Cycle 21 COS spectrum. In that spectra (as well as those obtained by FOS in 1997), the continuum flux was approximately  $10^{-15}$  erg/cm<sup>2</sup>/Ang. The STIS ETC gives a S/N~4 per unbinned pixel for a 10 ksec exposure (~4 orbits). The red and blue Ly $\alpha$  emission components were observed at  $(3-5) \times 10^{-15}$  in 2014. Four orbits at this level should provide S/N=7-10 per unbinned resel. Even if the line emission varies considerably, we will have usable data. The data will be extracted at full spatial and spectral resolution though for some applications, we will resample the line spread function to better match the COS/G130M resolution. Line profile fitting will be accomplished in much the same manner as was used for our Cycle 21 COS data.

Based on the observed continuum and line fluxes from our Cycle 21 COS observations, a single exposure of ~2500 seconds with the sensitive COS/G130M grating will give S/N~5 per resolution element.

Proposal 14631 - Disk axis - COS (01) - Resolving the Nuclear Structure of the Canonical Radio Galaxy M87

Tue Mar 28 01:00:34 GMT 2017

<b>Visit</b>	<b>Proposal 14631, Disk axis - COS (01), failed</b>				
	<b>Diagnostic Status: No Diagnostics</b>				
	Scientific Instruments: COS/FUV				
	Special Requirements: (none)				

<b>Fixed Targets</b>	#	Name	Target Coordinates	Targ. Coord. Corrections	Fluxes	Miscellaneous
	(1)	M-87	RA: 12 30 49.4234 (187.7059308d) Dec: +12 23 28.04 (12.39112d) Equinox: J2000		V=8.63	Reference Frame: ICRS
	<i>Comments: This object was generated by the target selector and retrieved from the SIMBAD database. Coords from VLBI centroid.</i>					
	<i>Extended=NO</i>					

<b>Exposures</b>	#	Label (ETC Run)	Target	Config, Mode, Aperture	Spectral Els.	Opt. Params.	Special Reqs.	Groups	Exp. Time (Total)/[Actual Dur.]	Orbit	
	1	(COS.sa.535 570)	(1) M-87	COS/FUV, ACQ/PEAKXD, PSA	G130M 1309 A				57 Secs (57 Secs) [==>]	[1]	
	<i>Comments: Steve Penton's recommended approach from Cy22/13489 Updated per de Rosa email 11/21/16</i>										
	2	(COS.sa.535 570)	(1) M-87	COS/FUV, ACQ/PEAKD, PSA	G130M 1309 A		NUM-POS=5; STEP-SIZE=1		37 Secs (37 Secs) [==>]	[1]	
	<i>Comments: Updated per de Rosa email 11/21/16</i>										
	3	(COS.sp.510 442)	(1) M-87	COS/FUV, TIME-TAG, PSA	G130M 1309 A		BUFFER-TIME=60 0; FP-POS=1		500 Secs (443 Secs) [==>443.0 Secs ]	[1]	
	4	(COS.sp.510 442)	(1) M-87	COS/FUV, TIME-TAG, PSA	G130M 1309 A		BUFFER-TIME=60 0; FP-POS=2		500 Secs (443 Secs) [==>443.0 Secs ]	[1]	
	5	(COS.sp.510 442)	(1) M-87	COS/FUV, TIME-TAG, PSA	G130M 1309 A		BUFFER-TIME=60 0; FP-POS=3		500 Secs (443 Secs) [==>443.0 Secs ]	[1]	
	6	(COS.sp.510 442)	(1) M-87	COS/FUV, TIME-TAG, PSA	G130M 1309 A		BUFFER-TIME=60 0; FP-POS=4		500 Secs (443 Secs) [==>443.0 Secs ]	[1]	

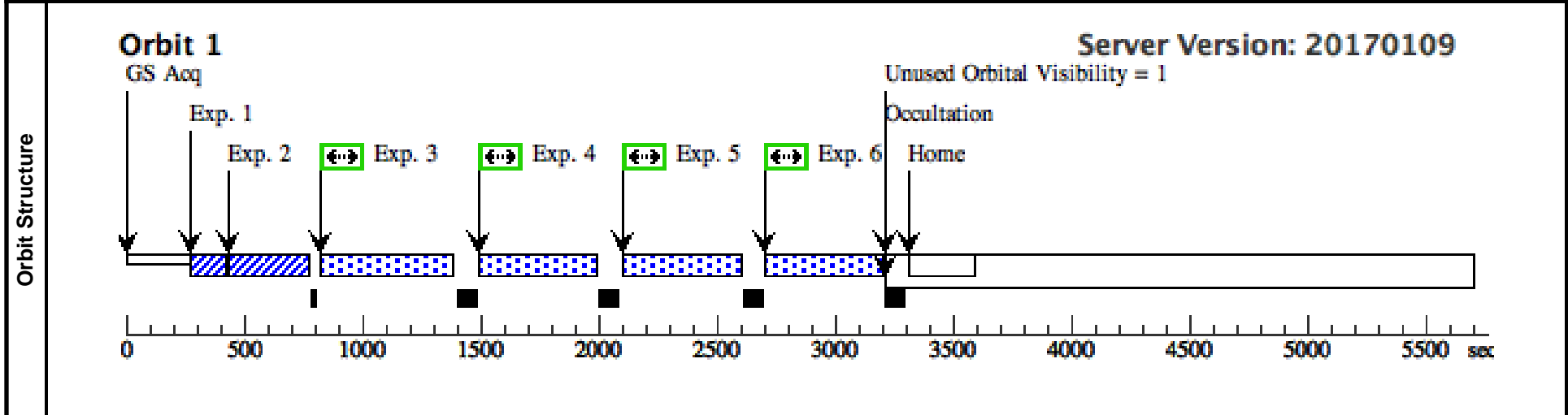

Proposal 14631 - Disk axis - COS (05) - Resolving the Nuclear Structure of the Canonical Radio Galaxy M87

Tue Mar 28 01:00:34 GMT 2017

Visit	<b>Proposal 14631, Disk axis - COS (05), completed</b> <b>Diagnostic Status: No Diagnostics</b> Scientific Instruments: COS/FUV Special Requirements: (none) <i>Comments: Repeat of visit 01. Visit 01 lost due to SIC &amp; DH safing event on Jan 13, 2017.</i>																					
	Fixed Targets	<table border="1"> <thead> <tr> <th>#</th> <th>Name</th> <th>Target Coordinates</th> <th>Targ. Coord. Corrections</th> <th>Fluxes</th> <th>Miscellaneous</th> </tr> </thead> <tbody> <tr> <td>(1)</td> <td>M-87</td> <td>RA: 12 30 49.4234 (187.7059308d) Dec: +12 23 28.04 (12.39112d) Equinox: J2000</td> <td></td> <td>V=8.63</td> <td>Reference Frame: ICRS</td> </tr> </tbody> </table> <i>Comments: This object was generated by the target selector and retrieved from the SIMBAD database. Coords from VLBI centroid.</i> Extended=NO										#	Name	Target Coordinates	Targ. Coord. Corrections	Fluxes	Miscellaneous	(1)	M-87	RA: 12 30 49.4234 (187.7059308d) Dec: +12 23 28.04 (12.39112d) Equinox: J2000		V=8.63
#	Name	Target Coordinates	Targ. Coord. Corrections	Fluxes	Miscellaneous																	
(1)	M-87	RA: 12 30 49.4234 (187.7059308d) Dec: +12 23 28.04 (12.39112d) Equinox: J2000		V=8.63	Reference Frame: ICRS																	
Exposures	#	Label (ETC Run)	Target	Config,Mode,Aperture	Spectral Els.	Opt. Params.	Special Reqs.	Groups	Exp. Time (Total)/[Actual Dur.]	Orbit												
	1	(COS.sa.535 570)	(1) M-87	COS/FUV, ACQ/PEAKXD, PSA	G130M 1309 A				57 Secs (57 Secs) [==>]	[1]												
	<i>Comments: Steve Penton's recommended approach from Cy22/13489</i>																					
	<i>Updated per de Rosa email 11/21/16</i>																					
	2	(COS.sa.535 570)	(1) M-87	COS/FUV, ACQ/PEAKD, PSA	G130M 1309 A		NUM-POS=5; STEP-SIZE=1			37 Secs (37 Secs) [==>]	[1]											
	<i>Comments: Updated per de Rosa email 11/21/16</i>																					
	3	(COS.sp.510 442)	(1) M-87	COS/FUV, TIME-TAG, PSA	G130M 1309 A		BUFFER-TIME=60 0; FP-POS=1			500 Secs (443 Secs) [==>443.0 Secs ]	[1]											
4	(COS.sp.510 442)	(1) M-87	COS/FUV, TIME-TAG, PSA	G130M 1309 A		BUFFER-TIME=60 0; FP-POS=2			500 Secs (443 Secs) [==>443.0 Secs ]	[1]												
5	(COS.sp.510 442)	(1) M-87	COS/FUV, TIME-TAG, PSA	G130M 1309 A		BUFFER-TIME=60 0; FP-POS=3			500 Secs (443 Secs) [==>443.0 Secs ]	[1]												
6	(COS.sp.510 442)	(1) M-87	COS/FUV, TIME-TAG, PSA	G130M 1309 A		BUFFER-TIME=60 0; FP-POS=4			500 Secs (443 Secs) [==>443.0 Secs ]	[1]												

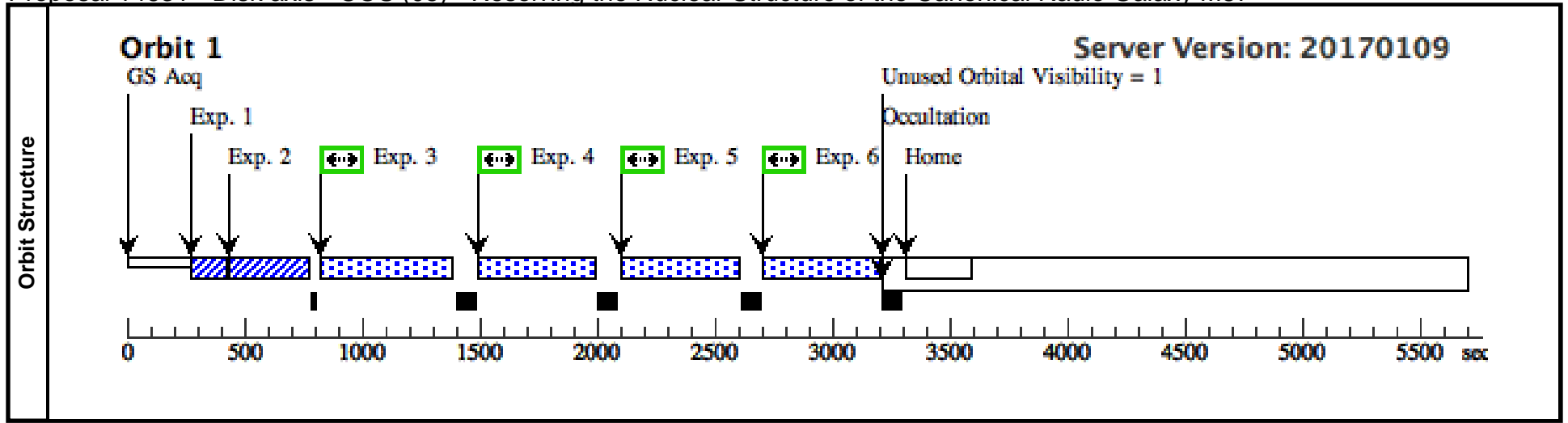

Proposal 14631 - Disk axis - STIS (02) - Resolving the Nuclear Structure of the Canonical Radio Galaxy M87

Tue Mar 28 01:00:34 GMT 2017

Visit	<b>Proposal 14631, Disk axis - STIS (02), completed</b> <b>Diagnostic Status: No Diagnostics</b> Scientific Instruments: STIS/CCD, STIS/FUV-MAMA Special Requirements: ORIENT 45D TO 85 D; ORIENT 225D TO 265 D; GROUP 02,01 WITHIN 12H <i>Comments: Slit position parallel to M87 Jet axis.</i>									
	Fixed Targets	#	Name	Target Coordinates	Targ. Coord. Corrections	Fluxes	Miscellaneous			
	(1)	M-87	RA: 12 30 49.4234 (187.7059308d) Dec: +12 23 28.04 (12.39112d) Equinox: J2000		V=8.63	Reference Frame: ICRS				
	<i>Comments: This object was generated by the target selector and retrieved from the SIMBAD database. Coords from VLBI centroid. Extended=NO</i>									
Exposures	#	Label (ETC Run)	Target	Config,Mode,Aperture	Spectral Els.	Opt. Params.	Special Reqs.	Groups	Exp. Time (Total)/[Actual Dur.]	Orbit
	1	(STIS.ta.825 088)	(1) M-87	STIS/CCD, ACQ, F28X500II	MIRROR	ACQTYPE=DIFFUSE; CHECKBOX=11; DIFFUSE-CENTER=FLUX-CENTROID	GS ACQ SCENARIO BASE1B3		2.0 Secs (2 Secs) [==>]	[1]
	<i>Comments: Nucleus is close to a point source, but may be extended. I'm using checkbox=11 (0.5 arcsec box) to avoid possible confusion by HST knot 1. Assuming V=9 here. Can I get away with using ACQTYPE=POINT here? PC image shows marginally-resolved source.</i>									
	2	(STIS.sp.82 5090)	(1) M-87	STIS/FUV-MAMA, TIME-TAG, 52X0.2	G140M 1222 A	BUFFER-TIME=10 00			2000 Secs (2226 Secs) [==>2226.0 Secs ]	[1]
	3	(STIS.sp.82 5090)	(1) M-87	STIS/FUV-MAMA, TIME-TAG, 52X0.2	G140M 1222 A	BUFFER-TIME=10 00			2500 Secs (2966 Secs) [==>2966.0 Secs ]	[2]
	4	(STIS.sp.82 5090)	(1) M-87	STIS/FUV-MAMA, TIME-TAG, 52X0.2	G140M 1222 A	BUFFER-TIME=10 00			2500 Secs (2966 Secs) [==>2966.0 Secs ]	[3]
5	(STIS.sp.82 5090)	(1) M-87	STIS/FUV-MAMA, TIME-TAG, 52X0.2	G140M 1222 A	BUFFER-TIME=10 00			2500 Secs (2966 Secs) [==>2966.0 Secs ]	[4]	

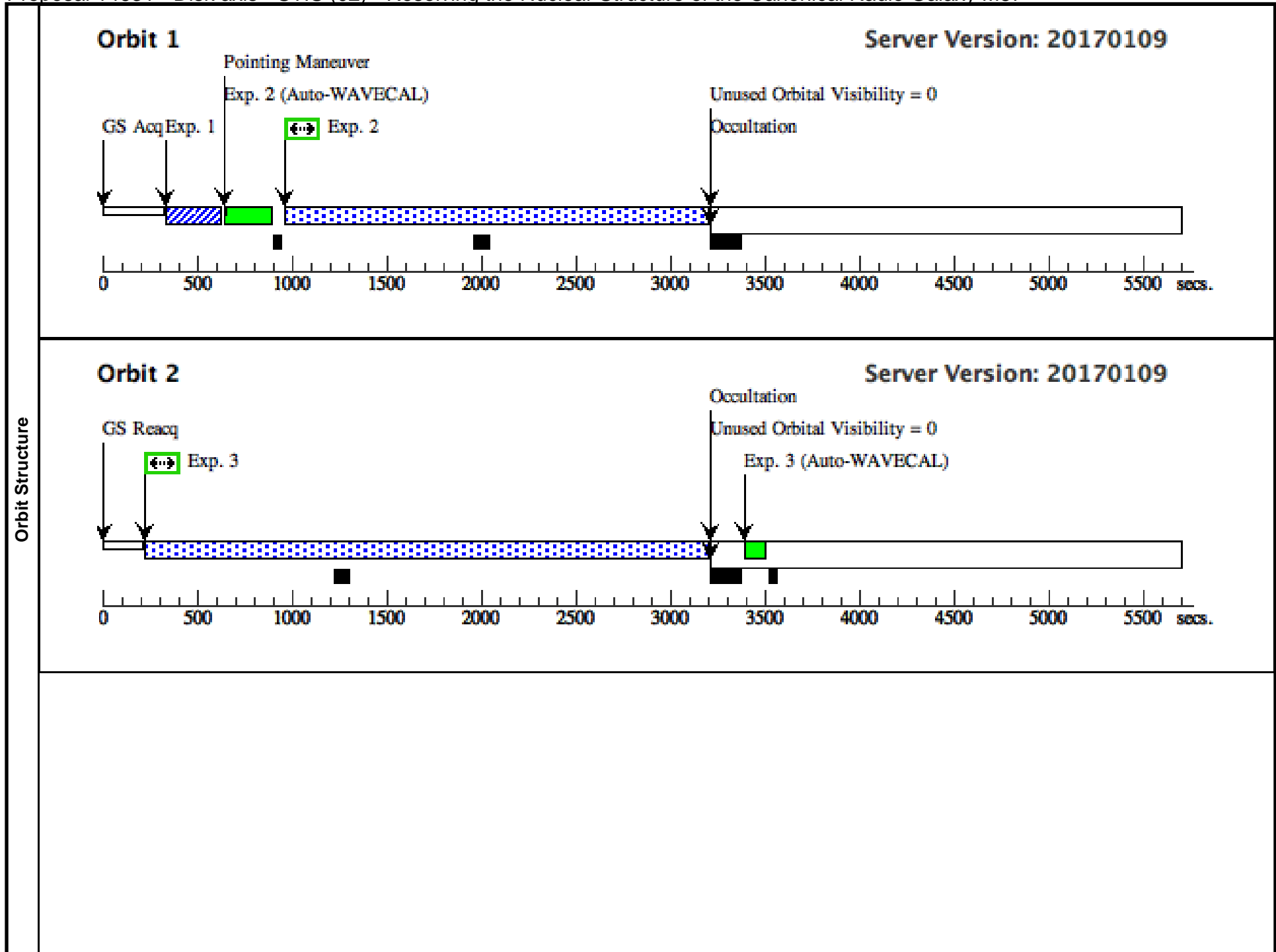

### Orbit 3

Server Version: 20170109

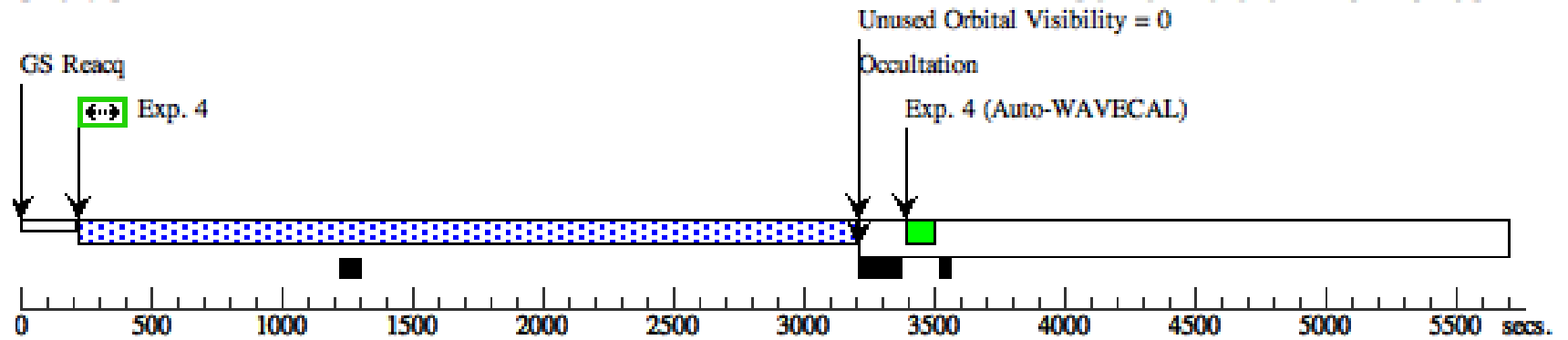

### Orbit 4

Server Version: 20170109

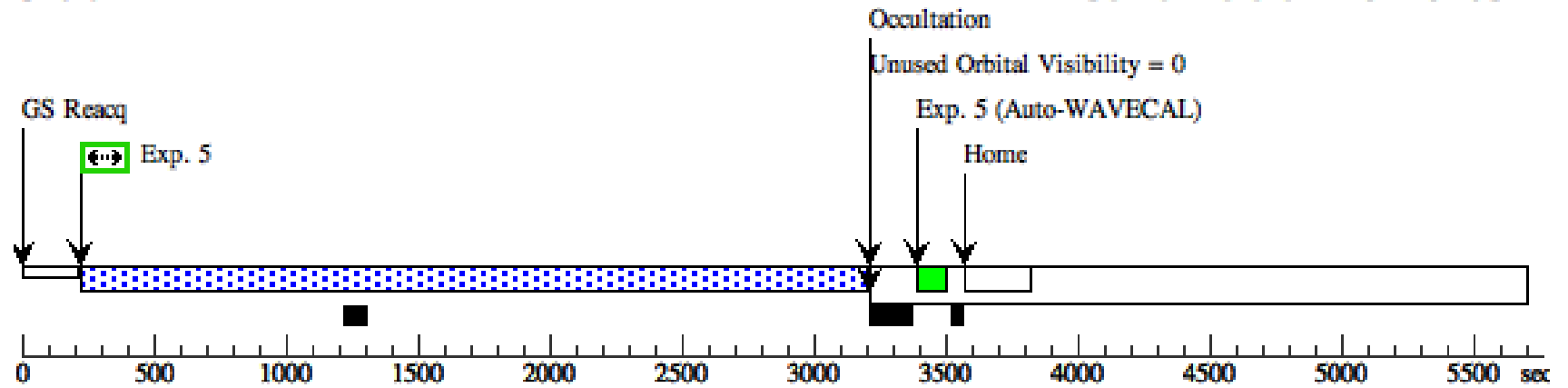

Proposal 14631 - Jet axis - COS (03) - Resolving the Nuclear Structure of the Canonical Radio Galaxy M87

Tue Mar 28 01:00:34 GMT 2017

<b>Visit</b>	<b>Proposal 14631, Jet axis - COS (03), implementation</b>				
	<b>Diagnostic Status: No Diagnostics</b>				
	Scientific Instruments: COS/FUV				
	Special Requirements: (none)				

<b>Fixed Targets</b>	#	Name	Target Coordinates	Targ. Coord. Corrections	Fluxes	Miscellaneous
	(1)	M-87	RA: 12 30 49.4234 (187.7059308d) Dec: +12 23 28.04 (12.39112d) Equinox: J2000		V=8.63	Reference Frame: ICRS
	<i>Comments: This object was generated by the target selector and retrieved from the SIMBAD database. Coords from VLBI centroid.</i>					
	<i>Extended=NO</i>					

<b>Exposures</b>	#	Label (ETC Run)	Target	Config,Mode,Aperture	Spectral Els.	Opt. Params.	Special Reqs.	Groups	Exp. Time (Total)/[Actual Dur.]	Orbit	
	1	(COS.sa.535 570)	(1) M-87	COS/FUV, ACQ/PEAKXD, PSA	G130M 1309 A				57 Secs (57 Secs) [==>]	[1]	
	<i>Comments: Steve Penton's recommended approach from Cy22/13489 Updated per de Rosa email 11/21/16</i>										
	2	(COS.sa.535 570)	(1) M-87	COS/FUV, ACQ/PEAKD, PSA	G130M 1309 A		NUM-POS=5; STEP-SIZE=1		37 Secs (37 Secs) [==>]	[1]	
	<i>Comments: Updated per de Rosa email 11/21/16</i>										
	3	(COS.sp.510 442)	(1) M-87	COS/FUV, TIME-TAG, PSA	G130M 1309 A		BUFFER-TIME=60 0; FP-POS=1		600 Secs (443 Secs) [==>443.0 Secs ]	[1]	
	4	(COS.sp.510 442)	(1) M-87	COS/FUV, TIME-TAG, PSA	G130M 1309 A		BUFFER-TIME=60 0; FP-POS=2		600 Secs (443 Secs) [==>443.0 Secs ]	[1]	
	5	(COS.sp.510 442)	(1) M-87	COS/FUV, TIME-TAG, PSA	G130M 1309 A		BUFFER-TIME=60 0; FP-POS=3		600 Secs (443 Secs) [==>443.0 Secs ]	[1]	
	6	(COS.sp.510 442)	(1) M-87	COS/FUV, TIME-TAG, PSA	G130M 1309 A		BUFFER-TIME=60 0; FP-POS=4		600 Secs (443 Secs) [==>443.0 Secs ]	[1]	

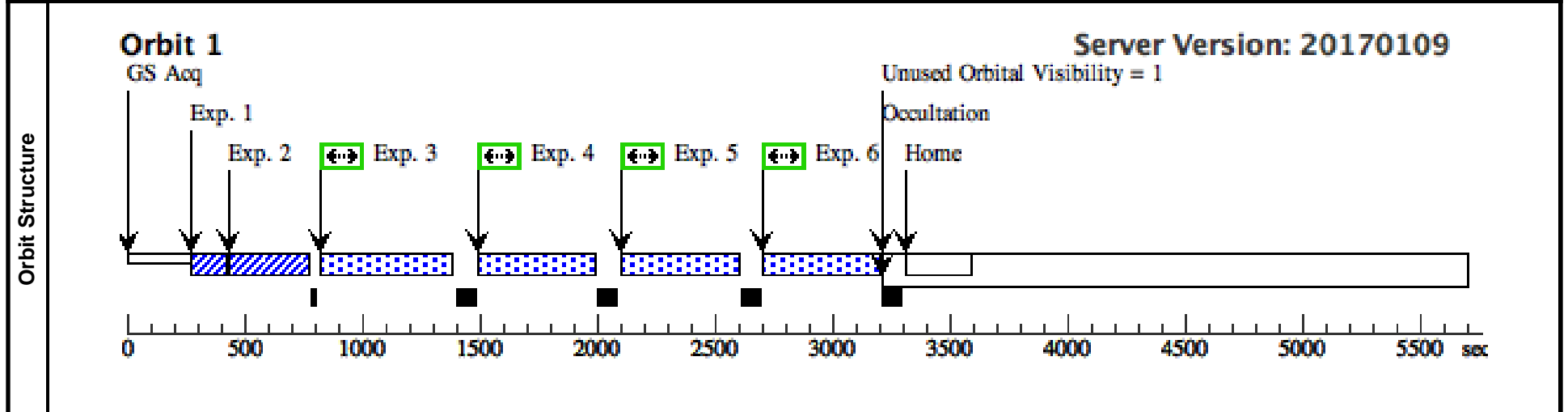

Proposal 14631 - Jet axis - STIS (04) - Resolving the Nuclear Structure of the Canonical Radio Galaxy M87

<b>Visit</b>	<b>Proposal 14631, Jet axis - STIS (04), implementation</b> <span style="float: right;">Tue Mar 28 01:00:34 GMT 2017</span> <b>Diagnostic Status: No Diagnostics</b> Scientific Instruments: STIS/CCD, STIS/FUV-MAMA Special Requirements: ORIENT 148.0D TO 156.5 D; ORIENT 333.5D TO 336.5 D; GROUP 04,03 WITHIN 24H <i>Comments: Slit position parallel to M87 Jet axis.</i>					
	<b>Fixed Targets</b>	<b>#</b>	<b>Name</b>	<b>Target Coordinates</b>	<b>Targ. Coord. Corrections</b>	<b>Fluxes</b>
	(1)	M-87	RA: 12 30 49.4234 (187.7059308d) Dec: +12 23 28.04 (12.39112d) Equinox: J2000		V=8.63	Reference Frame: ICRS
	<i>Comments: This object was generated by the target selector and retrieved from the SIMBAD database. Coords from VLBI centroid.                  Extended=NO</i>					

Proposal 14631 - Jet axis - STIS (04) - Resolving the Nuclear Structure of the Canonical Radio Galaxy M87

#	Label (ETC Run)	Target	Config,Mode,Aperture	Spectral Els.	Opt. Params.	Special Reqs.	Groups	Exp. Time (Total)/[Actual Dur.]	Orbit	
Exposures	1	(STIS.ta.908 (1) M-87 565)	STIS/CCD, ACQ, F28X50LP	MIRROR	ACQTYPE=DIFFU SE; CHECKBOX=5; DIFFUSE-CENTER =FLUX-CENTROID	GS ACQ SCENARI O SINGLE		10.0 Secs (10 Secs) [==>]	[1]	
	<p><i>Comments: Nucleus is close to a point source, but may be extended. Can I get away with using ACQTYPE=POINT? PC image shows marginally-resolved source.</i></p> <p><i>Based on advice from STIS team, I'm choosing a 5x5 pix search box.</i></p> <p><i>Assuming F(5500)=4e-16 erg/cm/s/Ang</i></p>									
	2	(STIS.sp.82 (1) M-87 5090)	STIS/FUV-MAMA, TIME-TAG, 52X0.2	G140M 1222 A	BUFFER-TIME=10 00			2000 Secs (2337 Secs) [==>2337.0 Secs ]	[1]	
	3	(STIS.ta.908 (1) M-87 565)	STIS/CCD, ACQ, F28X50LP	MIRROR	ACQTYPE=DIFFU SE; CHECKBOX=5; DIFFUSE-CENTER =FLUX-CENTROID			10.0 Secs (10 Secs) [==>]	[2]	
	<p><i>Comments: Nucleus is close to a point source, but may be extended. Can I get away with using ACQTYPE=POINT? PC image shows marginally-resolved source.</i></p> <p><i>Based on advice from STIS team, I'm choosing a 5x5 pix search box.</i></p> <p><i>Assuming F(5500)=4e-16 erg/cm/s/Ang</i></p>									
	4	(STIS.sp.82 (1) M-87 5090)	STIS/FUV-MAMA, TIME-TAG, 52X0.2	G140M 1222 A	BUFFER-TIME=10 00			2500 Secs (2244 Secs) [==>2244.0 Secs ]	[2]	
	5	(STIS.ta.908 (1) M-87 565)	STIS/CCD, ACQ, F28X50LP	MIRROR	ACQTYPE=DIFFU SE; CHECKBOX=5; DIFFUSE-CENTER =FLUX-CENTROID			10.0 Secs (10 Secs) [==>]	[3]	
	<p><i>Comments: Nucleus is close to a point source, but may be extended. Can I get away with using ACQTYPE=POINT? PC image shows marginally-resolved source.</i></p> <p><i>Based on advice from STIS team, I'm choosing a 5x5 pix search box.</i></p> <p><i>Assuming F(5500)=4e-16 erg/cm/s/Ang</i></p>									
6	(STIS.sp.82 (1) M-87 5090)	STIS/FUV-MAMA, TIME-TAG, 52X0.2	G140M 1222 A	BUFFER-TIME=10 00			2500 Secs (2244 Secs) [==>2244.0 Secs ]	[3]		
7	(STIS.ta.908 (1) M-87 565)	STIS/CCD, ACQ, F28X50LP	MIRROR	ACQTYPE=DIFFU SE; CHECKBOX=5; DIFFUSE-CENTER =FLUX-CENTROID			10.0 Secs (10 Secs) [==>]	[4]		
<p><i>Comments: Nucleus is close to a point source, but may be extended. Can I get away with using ACQTYPE=POINT? PC image shows marginally-resolved source.</i></p> <p><i>Based on advice from STIS team, I'm choosing a 5x5 pix search box.</i></p> <p><i>Assuming F(5500)=4e-16 erg/cm/s/Ang</i></p>										
8	(STIS.sp.82 (1) M-87 5090)	STIS/FUV-MAMA, TIME-TAG, 52X0.2	G140M 1222 A	BUFFER-TIME=10 00			2500 Secs (2244 Secs) [==>2244.0 Secs ]	[4]		

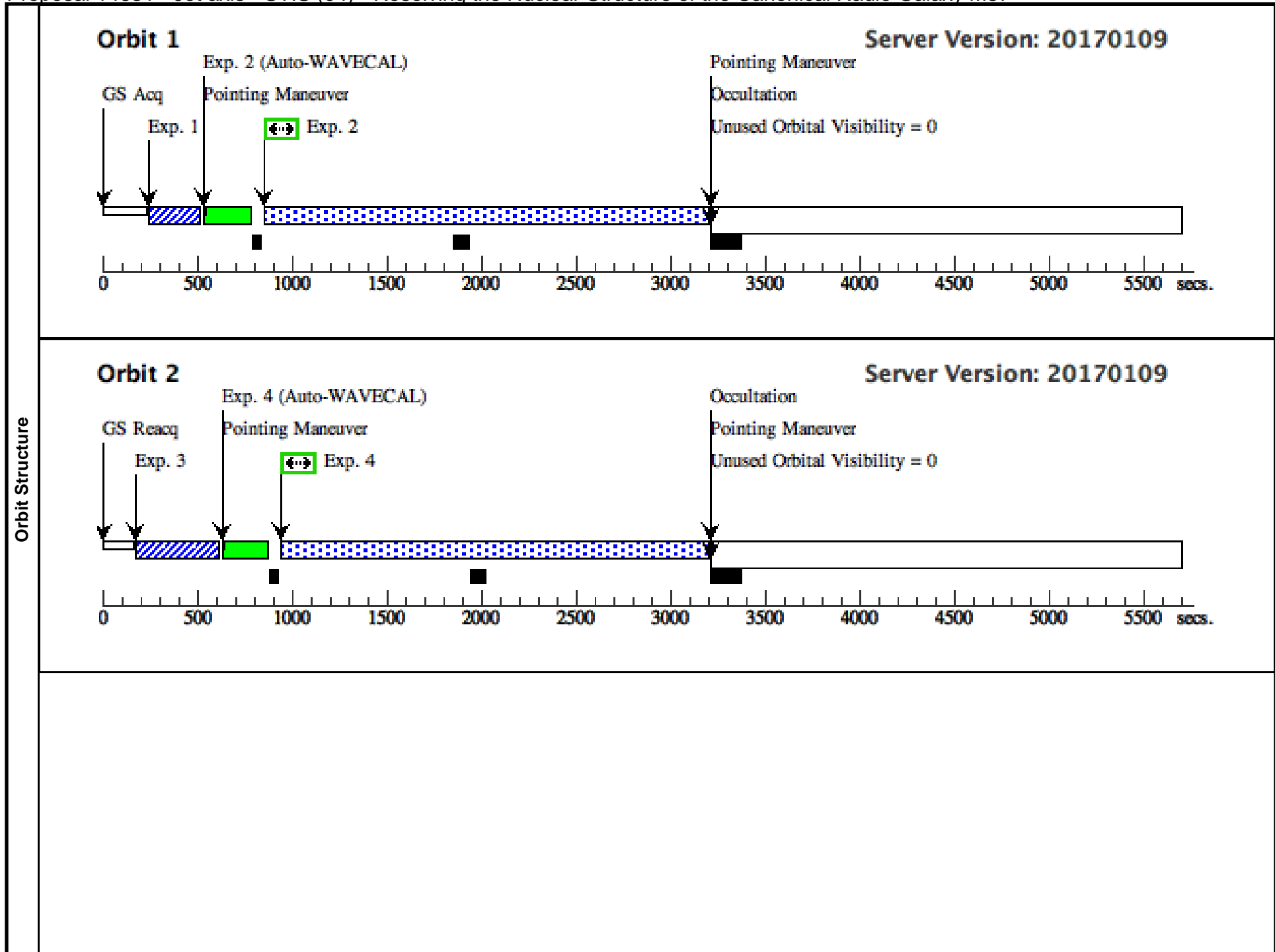

**Orbit 3**

Server Version: 20170109

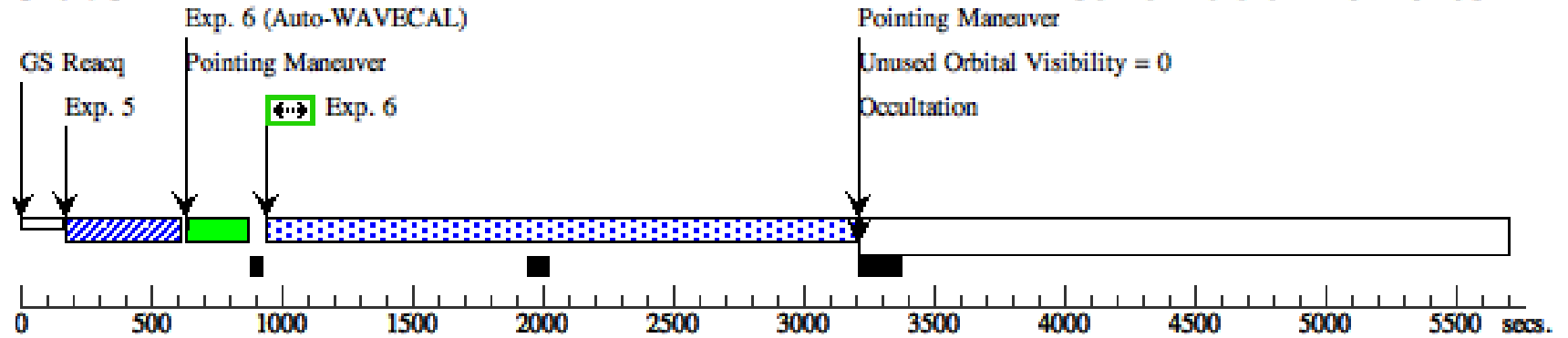

**Orbit 4**

Server Version: 20170109

