



14741 - MY Cam: can homogeneous evolution produce gravitational-wave progenitors?

Cycle: 24, Proposal Category: GO

(Availability Mode: SUPPORTED)

INVESTIGATORS

<i>Name</i>	<i>Institution</i>	<i>E-Mail</i>
Dr. Ignacio Negueruela (PI) (ESA Member) (Contact)	Universidad de Alicante, Dpto de Fisica	ignacio@disc.ua.es
Dr. Miriam Garcia (CoI) (ESA Member) (Contact)	Centro de Astrobiologia (CSIC/INTA) Inst. Nac. de Tec. Aero.	mgg@cab.inta-csic.es
Dr. Javier Lorenzo (CoI) (ESA Member)	Universidad de Alicante, Dpto de Fisica	javihd64315@gmail.com
Dr. Paco Najarro (CoI) (ESA Member)	Centro de Astrobiologia (CSIC/INTA) Inst. Nac. de Tec. Aero.	najarro@cab.inta-csic.es
Dr. Jesus Maiz Apellaniz (CoI) (ESA Member)	Centro de Astrobiologia (CSIC/INTA) Inst. Nac. de Tec. Aero.	jmaiz@cab.inta-csic.es
Dr. Sergio Simon-Diaz (CoI) (ESA Member)	Instituto de Astrofisica de Canarias	ssimon@iac.es
Dr. Amparo Marco (CoI) (ESA Member)	Universidad de Alicante, Dpto de Fisica	tobarra@dfists.ua.es
Prof. Artemio Herrero (CoI) (ESA Member)	Instituto de Astrofisica de Canarias	ahd@ll.iac.es

VISITS

<i>Visit</i>	<i>Targets used in Visit</i>	<i>Configurations used in Visit</i>	<i>Orbits Used</i>	<i>Last Orbit Planner Run</i>	<i>OP Current with Visit?</i>
01	(1) MY-CAM	STIS/CCD STIS/FUV-MAMA	1	29-Jul-2016 15:10:10.0	yes
02	(1) MY-CAM	STIS/CCD STIS/FUV-MAMA STIS/NUV-MAMA	1	29-Jul-2016 15:10:11.0	yes

Proposal 14741 (STScI Edit Number: 0, Created: Friday, July 29, 2016 2:10:18 PM EST) - Overview

<i>Visit</i>	<i>Targets used in Visit</i>	<i>Configurations used in Visit</i>	<i>Orbits Used</i>	<i>Last Orbit Planner Run</i>	<i>OP Current with Visit?</i>
03	(1) MY-CAM	STIS/CCD STIS/FUV-MAMA	1	29-Jul-2016 15:10:12.0	yes
04	(1) MY-CAM	STIS/CCD STIS/FUV-MAMA STIS/NUV-MAMA	1	29-Jul-2016 15:10:13.0	yes
05	(1) MY-CAM	STIS/CCD STIS/FUV-MAMA	1	29-Jul-2016 15:10:14.0	yes
06	(1) MY-CAM	STIS/CCD STIS/FUV-MAMA STIS/NUV-MAMA	1	29-Jul-2016 15:10:15.0	yes
07	(2) ALS7833	STIS/CCD STIS/FUV-MAMA STIS/NUV-MAMA	2	29-Jul-2016 15:10:17.0	yes

8 Total Orbits Used

ABSTRACT

Besides opening the era of gravitational-wave astrophysics, GW150914 has revolutionized the field of massive stars. GW150914 proves the existence of stellar-mass black holes in a configuration that current models for stellar evolution can only reproduce in special conditions of homogeneous evolution and/or low metallicity.

Only a handful of very-massive binaries that could lead to a binary black hole are known. We request UV spectroscopy of MY Cam (38Msun+32Msun), the best laboratory to test several predictions by current models, in order to derive stellar abundances and wind parameters that are inaccessible from the ground. Together with our previous photometric and spectroscopic exhaustive coverage, the STIS spectra will be key to characterize the pre-common envelope phase and test the homogeneous evolution hypothesis, critical ingredients of the different progenitor scenarios proposed to explain GW15091.

OBSERVING DESCRIPTION

Summary:

The observations consist on 6 visits on MY Cam, 1 orbit long each, and 1 visit on ALS 7833 with a 2 orbit duration.

Goal: ensure $\text{SNR} \geq 10$ at the spectral transitions of interest.

Instrument configurations: STIS-E140M, and STIS-E230M with $\lambda_{\text{central}} = 1978\text{\AA}$. Standard 0.2×0.2 echelle aperture.

Details:

Full UV coverage (1150-2381Å), high resolution spectra ($R \geq 30000$) of the doubled-line binary system MY Cam and the control star ALS 7833.

Both are bright targets and are located in the Milky Way.

High spectral resolution is needed to de-blend the photospheric lines of MY Cam and measure abundances.

Typical observing sequence for 1 orbit:

- CCD imaging acquisition ACQ
- (since we are using the standard 0.2×0.2 aperture, we do not request ACQ/PEAK acquisition).
- E140M spectroscopy
- E230M spectroscopy (only in half of the orbits)

Relevant lines:

- NV 1238.8, 1242.8, SiIV 1393.8, 1402.8, CIV 1548.2, 1550.8, NIV 1718.0, 1718.5.
- CIV 1168.8, 1169, CIII 1175.7, NIII 1182, 1184, OIV 1339, 1343 and OV 1371.
- Fe and Fe-group lines in the ~ 1250 - 1530\AA range.
- The full E140M+230M coverage of 1150-2381Å will additionally yield the extinction law towards MY CAM and ALS 7833. This point is crucial to accurately determine stellar luminosities, again crucial to the program.

Exposure times:

Calculated with the online STIS spectroscopic ETC v24.2

Proposal 14741 (STScI Edit Number: 0, Created: Friday, July 29, 2016 2:10:18 PM EST) - Overview

- UV flux simulated with observed Vmags, EBV, Rv. Castelli & Kurucz models
- Average zodiacal, Earth-shine and air-glow
- E140M setting: we expect signal to noise ratio SNR=30 at 1450A
- E230M : SNR=10 at NIV1718.0,1718.5 .

Time constraints:

We request observations of MY Cam at three epochs: quadrature and the 2 eclipses.

We have accurate orbital parameters for MY Cam .

Considering its short period (~1.2 days), we have broken all observations into separate visits to ensure observation of the required phases.

We set a Timing requirement around the required phases, with asymmetric tolerance: 0.02*period before (to account for time spent in acquisition) and 0.015*period after.

This should be enough to enclose all the spectroscopic science exposures.

The control star ALS 7833 is only requested in 1 epoch.

Safety checks:

- There exist no FUV spectra of any of the targets.
- FUV flux estimated with ETC, spectral types, V-mags and extinction
- > This produces no warning regarding local or global count rates

The BOT reports GALEX unknowns, but they must actually be our targets.

I have checked this in GALEXVIEW.

MYCAM and ALS7833 are in the field GALEX-AIS-52, and they are the brightest UV sources with in a 2arcmin diameter.

Proposal 14741 (STScI Edit Number: 0, Created: Friday, July 29, 2016 2:10:18 PM EST) - Overview

- FUV magnitudes from GALEX AIS: $m_{\text{FUV}}=12.025$ (MY Cam) and 12.13 (ALS 7833).
- Safe for our spectroscopic observations.
- Acquisition: neutral filter F25ND3.

MY Cam's photometric variability:

- Amplitude of only 0.3 magnitudes in the optical range
- No reported flares.
- No detection in X-rays or the high-energy domain
- > Short time-scale, hard-luminosity outbursts unlikely.

Proposal 14741 - MYCAM-FUV-PHI0 (01) - MY Cam: can homogeneous evolution produce gravitational-wave progenitors?

Fri Jul 29 19:10:18 GMT 2016

Visit	Proposal 14741, MYCAM-FUV-PHI0 (01)				
	Diagnostic Status: No Diagnostics				
	Scientific Instruments: STIS/CCD, STIS/FUV-MAMA				
	Special Requirements: Period 1.175392507 D AND ZERO-PHASE HJD2456948.292197				

#	Name	Target Coordinates	Targ. Coord. Corrections	Fluxes	Miscellaneous
(1)	MY-CAM	RA: 03 59 18.2925 (59.8262188d) Dec: +57 14 13.72 (57.23714d) Equinox: J2000		V=9.67+/-0.15 TYPE=O5.5V+O6.5V; B-V=0.2 8; Rv=2.74; E(B-V)=0.56; F-CO NT(1450)=1.2E-12; mFUV=12. 025pm0.003 (GALEX)	Reference Frame: ICRS
<i>Comments: Coordinates from Tycho-2 catalog. MY Cam is also in GSC2.3, with ID: NATB000186. Optical photometric data and extinction from Negueruela+Marco (2008) and Haug (1970). UV flux [erg/cm2/s/A] estimated by the ETC, using a O7V template, LMC2-law applied before normalization, and average airglow, zodiacal and earthshine. Extended=NO</i>					

#	Label (ETC Run)	Target	Config,Mode,Aperture	Spectral Els.	Opt. Params.	Special Reqs.	Groups	Exp. Time (Total)/[Actual Dur.]	Orbit
1	MYCAM-A CQ (STIS.ta.826 462)	(1) MY-CAM	STIS/CCD, ACQ, F25ND3	MIRROR	ACQTYPE=POINT	PHASE 0.98 TO 0.0 15		3 Secs (3 Secs) [==>]	[1]
2	MYCAM-F UV-1 (STIS.sp.82 6451)	(1) MY-CAM	STIS/FUV-MAMA, TIME-TAG, 0.2X0.2	E140M 1425 A	BUFFER-TIME=25 5.			2564. Secs (2564 Secs) [==>]	[1]

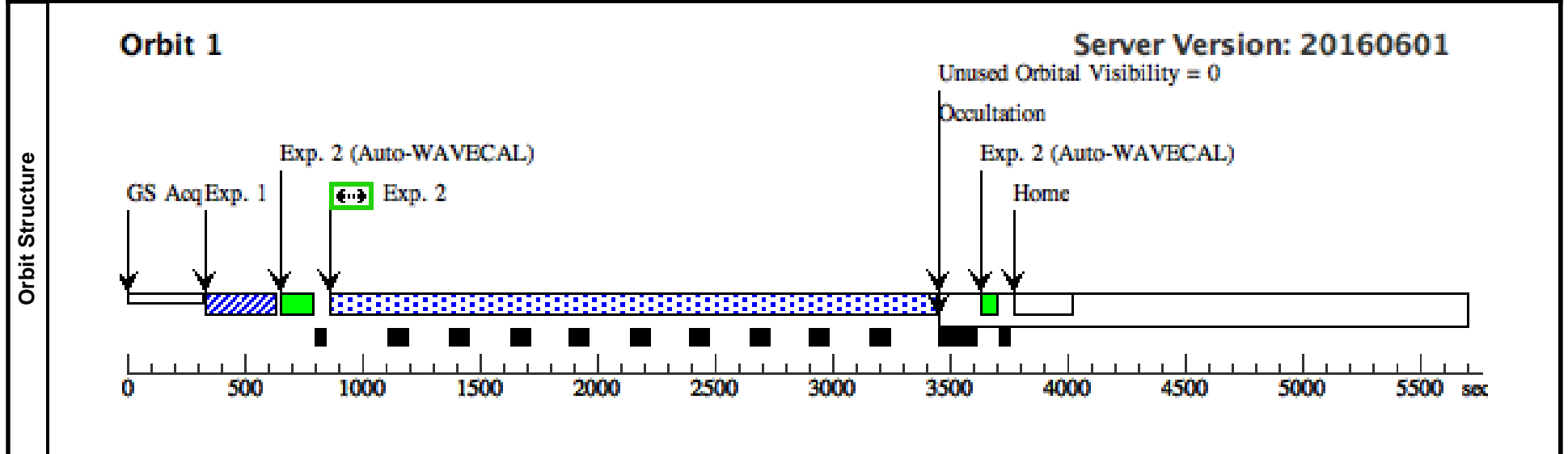

Proposal 14741 - MYCAM-NUV-PHI0 (02) - MY Cam: can homogeneous evolution produce gravitational-wave progenitors?

Fri Jul 29 19:10:18 GMT 2016

Visit	Proposal 14741, MYCAM-NUV-PHI0 (02)				
	Diagnostic Status: No Diagnostics				
	Scientific Instruments: STIS/NUV-MAMA, STIS/CCD, STIS/FUV-MAMA				
	Special Requirements: Period 1.175392507 D AND ZERO-PHASE HJD2456948.292197				

#	Name	Target Coordinates	Targ. Coord. Corrections	Fluxes	Miscellaneous
(1)	MY-CAM	RA: 03 59 18.2925 (59.8262188d)		V=9.67+/-0.15	Reference Frame: ICRS
	Alt Name1: TYC-3725-498-1	Dec: +57 14 13.72 (57.23714d)		TYPE=O5.5V+O6.5V; B-V=0.2	
	Alt Name2: BD+56D864	Equinox: J2000		8; Rv=2.74; E(B-V)=0.56; F-CO	
				NT(1450)=1.2E-12; mFUV=12.025pm0.003 (GALEX)	
<i>Comments: Coordinates from Tycho-2 catalog. MY Cam is also in GSC2.3, with ID: NATB000186. Optical photometric data and extinction from Negueruela+Marco (2008) and Haug (1970). UV flux [erg/cm2/s/A] estimated by the ETC, using a O7V template, LMC2-law applied before normalization, and average airglow, zodiacal and earthshine. Extended=NO</i>					

#	Label (ETC Run)	Target	Config,Mode,Aperture	Spectral Els.	Opt. Params.	Special Reqs.	Groups	Exp. Time (Total)/[Actual Dur.]	Orbit
1	MYCAM-A CQ (STIS.ta.826462)	(1) MY-CAM	STIS/CCD, ACQ, F25ND3	MIRROR	ACQTYPE=POINT	PHASE 0.98 TO 0.015		3 Secs (3 Secs) [==>]	[1]
2	MYCAM-F UV-2 (STIS.sp.826451)	(1) MY-CAM	STIS/FUV-MAMA, TIME-TAG, 0.2X0.2	E140M 1425 A	BUFFER-TIME=25 5.			1000. Secs (1000 Secs) [==>]	[1]
3	MYCAM-N UV (STIS.sp.826455)	(1) MY-CAM	STIS/NUV-MAMA, TIME-TAG, 0.2X0.2	E230M 1978 A	BUFFER-TIME=13 3			1077 Secs (1077 Secs) [==>]	[1]

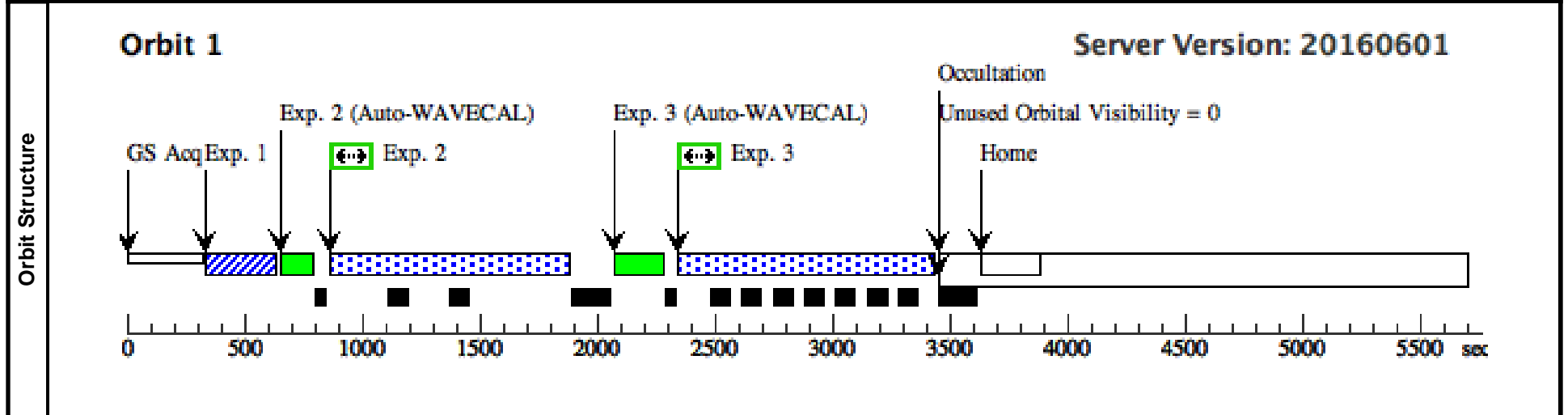

Proposal 14741 - MYCAM-FUV-PHI025 (03) - MY Cam: can homogeneous evolution produce gravitational-wave progenitors?

Fri Jul 29 19:10:18 GMT 2016

Visit	Proposal 14741, MYCAM-FUV-PHI025 (03)				
	Diagnostic Status: No Diagnostics				
	Scientific Instruments: STIS/CCD, STIS/FUV-MAMA				
	Special Requirements: Period 1.175392507 D AND ZERO-PHASE HJD2456948.292197				

#	Name	Target Coordinates	Targ. Coord. Corrections	Fluxes	Miscellaneous
(1)	MY-CAM	RA: 03 59 18.2925 (59.8262188d) Dec: +57 14 13.72 (57.23714d) Equinox: J2000		V=9.67+/-0.15 TYPE=O5.5V+O6.5V; B-V=0.2 8; Rv=2.74; E(B-V)=0.56; F-CO NT(1450)=1.2E-12; mFUV=12. 025pm0.003 (GALEX)	Reference Frame: ICRS
<i>Comments: Coordinates from Tycho-2 catalog. MY Cam is also in GSC2.3, with ID: NATB000186. Optical photometric data and extinction from Negueruela+Marco (2008) and Haug (1970). UV flux [erg/cm2/s/A] estimated by the ETC, using a O7V template, LMC2-law applied before normalization, and average airglow, zodiacal and earthshine. Extended=NO</i>					

#	Label (ETC Run)	Target	Config,Mode,Aperture	Spectral Els.	Opt. Params.	Special Reqs.	Groups	Exp. Time (Total)/[Actual Dur.]	Orbit
1	MYCAM-A CQ (STIS.ta.826 462)	(1) MY-CAM	STIS/CCD, ACQ, F25ND3	MIRROR	ACQTYPE=POINT	PHASE 0.23 TO 0.2 65		3 Secs (3 Secs) [==>]	[1]
2	MYCAM-F UV-1 (STIS.sp.82 6451)	(1) MY-CAM	STIS/FUV-MAMA, TIME-TAG, 0.2X0.2	E140M 1425 A	BUFFER-TIME=25 5.			2564. Secs (2564 Secs) [==>]	[1]

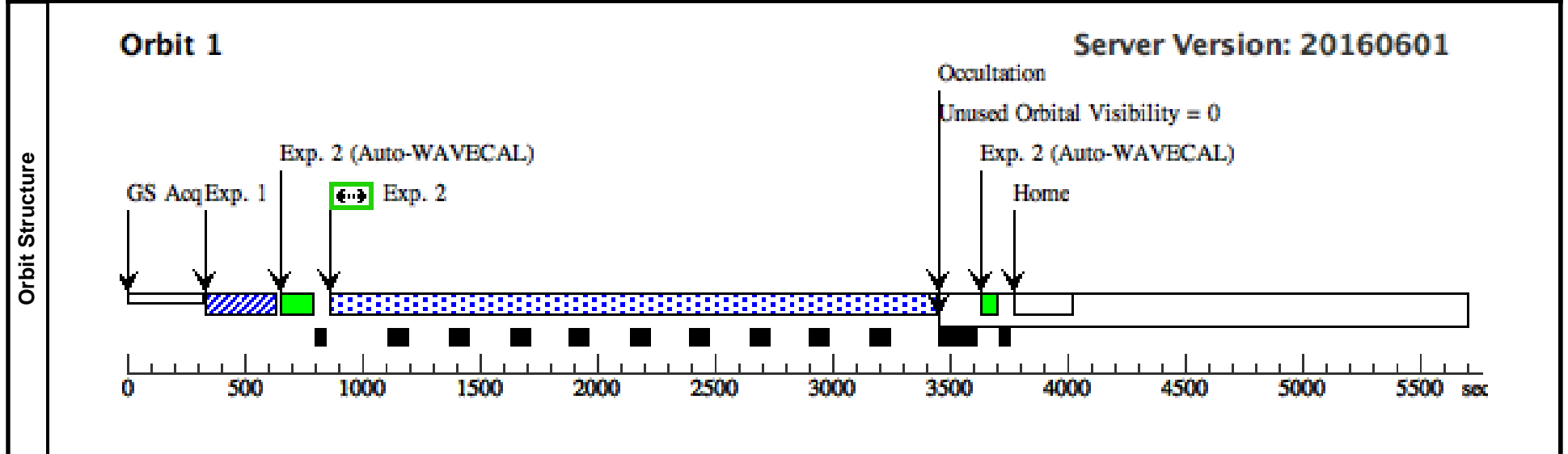

Proposal 14741 - MYCAM-NUV-PHI025 (04) - MY Cam: can homogeneous evolution produce gravitational-wave progenitors?

Fri Jul 29 19:10:18 GMT 2016

Visit	Proposal 14741, MYCAM-NUV-PHI025 (04)				
	Diagnostic Status: No Diagnostics				
	Scientific Instruments: STIS/NUV-MAMA, STIS/CCD, STIS/FUV-MAMA				
	Special Requirements: Period 1.175392507 D AND ZERO-PHASE HJD2456948.292197				

#	Name	Target Coordinates	Targ. Coord. Corrections	Fluxes	Miscellaneous
(1)	MY-CAM	RA: 03 59 18.2925 (59.8262188d)		V=9.67+/-0.15	Reference Frame: ICRS
	Alt Name1: TYC-3725-498-1	Dec: +57 14 13.72 (57.23714d)		TYPE=O5.5V+O6.5V; B-V=0.2	
	Alt Name2: BD+56D864	Equinox: J2000		8; Rv=2.74; E(B-V)=0.56; F-CO	
				NT(1450)=1.2E-12; mFUV=12.025pm0.003 (GALEX)	
<i>Comments: Coordinates from Tycho-2 catalog. MY Cam is also in GSC2.3, with ID: NATB000186. Optical photometric data and extinction from Negueruela+Marco (2008) and Haug (1970). UV flux [erg/cm2/s/A] estimated by the ETC, using a O7V template, LMC2-law applied before normalization, and average airglow, zodiacal and earthshine. Extended=NO</i>					

#	Label (ETC Run)	Target	Config,Mode,Aperture	Spectral Els.	Opt. Params.	Special Reqs.	Groups	Exp. Time (Total)/[Actual Dur.]	Orbit
1	MYCAM-A CQ (STIS.ta.826462)	(1) MY-CAM	STIS/CCD, ACQ, F25ND3	MIRROR	ACQTYPE=POINT	PHASE 0.23 TO 0.265		3 Secs (3 Secs) [==>]	[1]
2	MYCAM-F UV-2 (STIS.sp.826451)	(1) MY-CAM	STIS/FUV-MAMA, TIME-TAG, 0.2X0.2	E140M 1425 A	BUFFER-TIME=25 5.			1000. Secs (1000 Secs) [==>]	[1]
3	MYCAM-N UV (STIS.sp.826455)	(1) MY-CAM	STIS/NUV-MAMA, TIME-TAG, 0.2X0.2	E230M 1978 A	BUFFER-TIME=13 3			1077 Secs (1077 Secs) [==>]	[1]

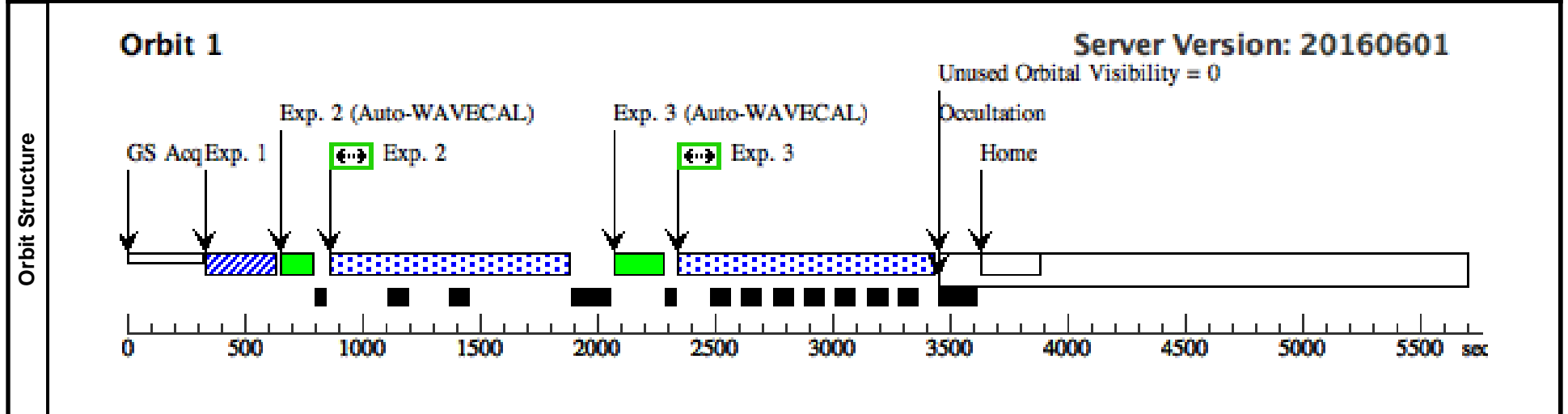

Proposal 14741 - MYCAM-FUV-PHI05 (05) - MY Cam: can homogeneous evolution produce gravitational-wave progenitors?

Fri Jul 29 19:10:18 GMT 2016

Visit	Proposal 14741, MYCAM-FUV-PHI05 (05)				
	Diagnostic Status: No Diagnostics				
	Scientific Instruments: STIS/CCD, STIS/FUV-MAMA				
	Special Requirements: Period 1.175392507 D AND ZERO-PHASE HJD2456948.292197				

#	Name	Target Coordinates	Targ. Coord. Corrections	Fluxes	Miscellaneous
(1)	MY-CAM	RA: 03 59 18.2925 (59.8262188d) Dec: +57 14 13.72 (57.23714d) Equinox: J2000		V=9.67+/-0.15 TYPE=O5.5V+O6.5V; B-V=0.2 8; Rv=2.74; E(B-V)=0.56; F-CO NT(1450)=1.2E-12; mFUV=12. 025pm0.003 (GALEX)	Reference Frame: ICRS
<i>Alt Name1: TYC-3725-498-1</i> <i>Alt Name2: BD+56D864</i>					
<i>Comments: Coordinates from Tycho-2 catalog.</i> <i>MY Cam is also in GSC2.3, with ID: NATB000186.</i> <i>Optical photometric data and extinction from Negueruela+Marco (2008) and Haug (1970).</i> <i>UV flux [erg/cm2/s/A] estimated by the ETC, using a O7V template, LMC2-law applied before normalization, and average airglow, zodiacal and earthshine.</i> <i>Extended=NO</i>					

#	Label (ETC Run)	Target	Config,Mode,Aperture	Spectral Els.	Opt. Params.	Special Reqs.	Groups	Exp. Time (Total)/[Actual Dur.]	Orbit
1	MYCAM-A CQ (STIS.ta.826 462)	(1) MY-CAM	STIS/CCD, ACQ, F25ND3	MIRROR	ACQTYPE=POINT	PHASE 0.48 TO 0.5 15		3 Secs (3 Secs) [==>]	[1]
2	MYCAM-F UV-1 (STIS.sp.82 6451)	(1) MY-CAM	STIS/FUV-MAMA, TIME-TAG, 0.2X0.2	E140M 1425 A	BUFFER-TIME=25 5.			2564. Secs (2564 Secs) [==>]	[1]

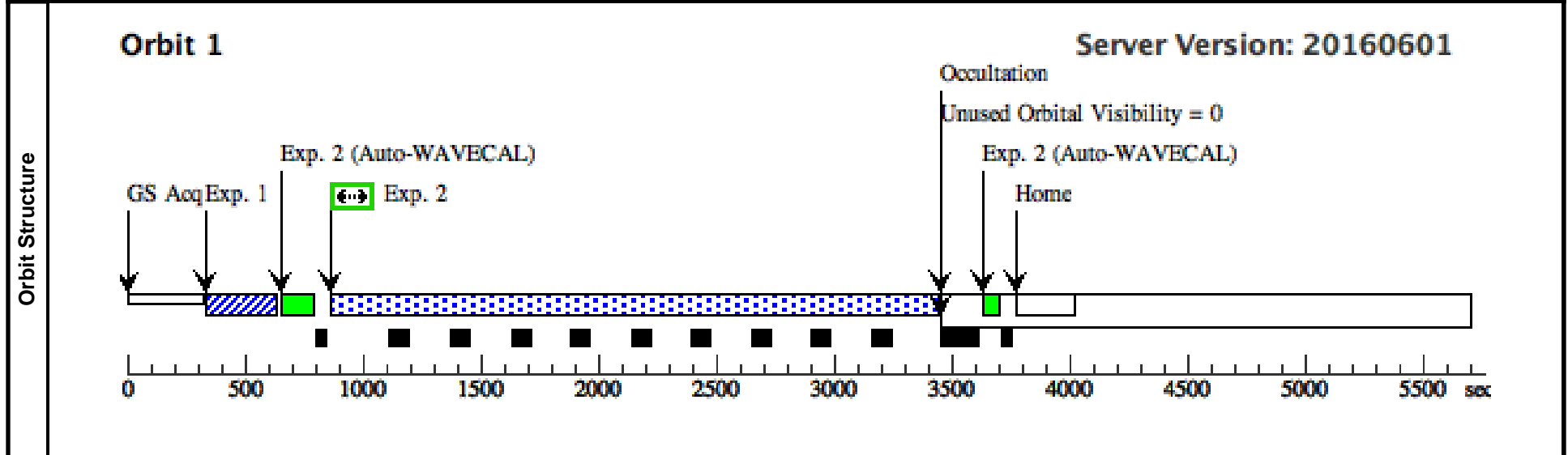

Proposal 14741 - MYCAM-NUV-PHI05 (06) - MY Cam: can homogeneous evolution produce gravitational-wave progenitors?

Fri Jul 29 19:10:18 GMT 2016

Visit	Proposal 14741, MYCAM-NUV-PHI05 (06)				
	Diagnostic Status: No Diagnostics				
	Scientific Instruments: STIS/NUV-MAMA, STIS/CCD, STIS/FUV-MAMA				
	Special Requirements: Period 1.175392507 D AND ZERO-PHASE HJD2456948.292197				

#	Name	Target Coordinates	Targ. Coord. Corrections	Fluxes	Miscellaneous
(1)	MY-CAM	RA: 03 59 18.2925 (59.8262188d)		V=9.67+/-0.15	Reference Frame: ICRS
	Alt Name1: TYC-3725-498-1	Dec: +57 14 13.72 (57.23714d)		TYPE=O5.5V+O6.5V; B-V=0.2	
	Alt Name2: BD+56D864	Equinox: J2000		8; Rv=2.74; E(B-V)=0.56; F-CO	
	<i>Comments: Coordinates from Tycho-2 catalog. MY Cam is also in GSC2.3, with ID: NATB000186. Optical photometric data and extinction from Negueruela+Marco (2008) and Haug (1970). UV flux [erg/cm2/s/A] estimated by the ETC, using a O7V template, LMC2-law applied before normalization, and average airglow, zodiacal and earthshine. Extended=NO</i>				

#	Label (ETC Run)	Target	Config,Mode,Aperture	Spectral Els.	Opt. Params.	Special Reqs.	Groups	Exp. Time (Total)/[Actual Dur.]	Orbit
1	MYCAM-A CQ (STIS.ta.826462)	(1) MY-CAM	STIS/CCD, ACQ, F25ND3	MIRROR	ACQTYPE=POINT	PHASE 0.48 TO 0.515		3 Secs (3 Secs) [==>]	[1]
2	MYCAM-F UV-2 (STIS.sp.826451)	(1) MY-CAM	STIS/FUV-MAMA, TIME-TAG, 0.2X0.2	E140M 1425 A	BUFFER-TIME=25 5.			1000. Secs (1000 Secs) [==>]	[1]
3	MYCAM-N UV (STIS.sp.826455)	(1) MY-CAM	STIS/NUV-MAMA, TIME-TAG, 0.2X0.2	E230M 1978 A	BUFFER-TIME=13 3			1077 Secs (1077 Secs) [==>]	[1]

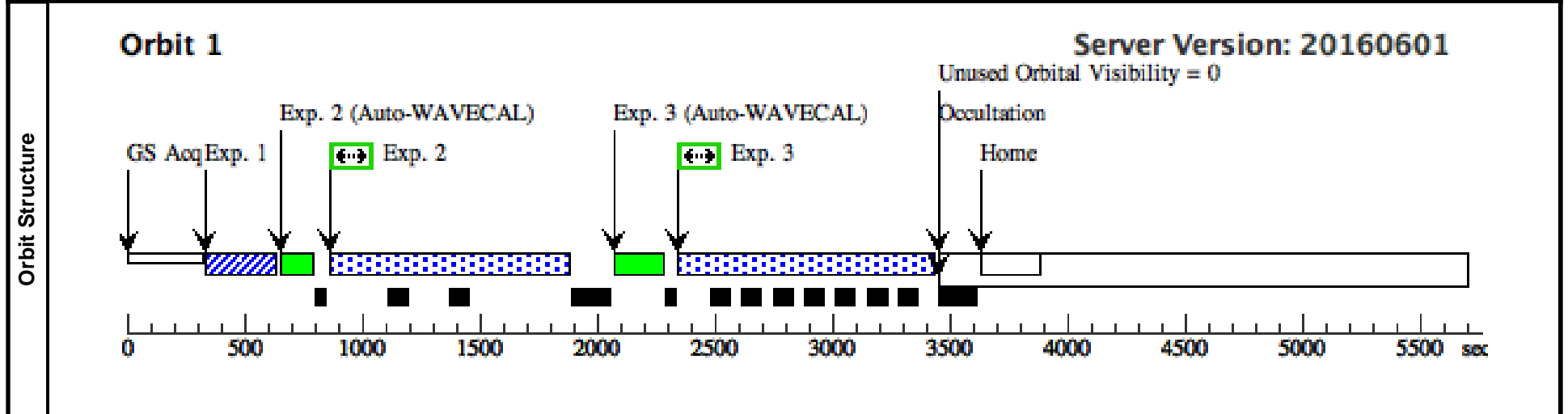

Proposal 14741 - ALS7833 (07) - MY Cam: can homogeneous evolution produce gravitational-wave progenitors?

Fri Jul 29 19:10:18 GMT 2016

Visit	Proposal 14741, ALS7833 (07) Diagnostic Status: No Diagnostics Scientific Instruments: STIS/NUV-MAMA, STIS/CCD, STIS/FUV-MAMA Special Requirements: (none)									
	Fixed Targets	#	Name	Target Coordinates	Targ. Coord. Corrections	Fluxes	Miscellaneous			
		(2)	ALS7833 Alt Name1: TYC-3725-866-1 Alt Name2: LSI+57-138	RA: 03 59 7.4917 (59.7812154d) Dec: +57 14 11.68 (57.23658d) Equinox: J2000		V=10.09+/-0.02 TYPE=O7V; B-V=0.28; Rv=3.2 ; E(B-V)=0.56; F-CONT(1450)=1.5E-12; mFUV=12.13pm0.003 (GALEX)	Reference Frame: ICRS			
	<i>Comments: Coordinates from Tycho-2 catalog. ALS7833 is also in GSC2.3, with ID: NATB000188 . Optical photometric data and extinction from Negueruela+Marco (2008) and Haug (1970). UV flux [erg/cm2/s/A] estimated by the ETC, using a O7V template, MW-law applied before normalization, and average airglow, zodiacal and earthshine. Extended=NO</i>									
Exposures	#	Label (ETC Run)	Target	Config,Mode,Aperture	Spectral Els.	Opt. Params.	Special Reqs.	Groups	Exp. Time (Total)/[Actual Dur.]	Orbit
	1	ALS7833-A CQ (STIS.ta.826 464)	(2) ALS7833	STIS/CCD, ACQ, F25ND3	MIRROR	ACQTYPE=POINT			4 Secs (4 Secs) [==>]	[1]
	2	ALS7833-F UV1 (STIS.sp.82 6457)	(2) ALS7833	STIS/FUV-MAMA, TIME-TAG, 0.2X0.2	E140M 1425 A	BUFFER-TIME=21 0.			2560. Secs (2560 Secs) [==>]	[1]
	3	ALS7833-F UV2 (STIS.sp.82 6457)	(2) ALS7833	STIS/FUV-MAMA, TIME-TAG, 0.2X0.2	E140M 1425 A	BUFFER-TIME=21 0.			717 Secs (717 Secs) [==>]	[2]
	4	ALS7833-N UV (STIS.sp.82 6456)	(2) ALS7833	STIS/NUV-MAMA, TIME-TAG, 0.2X0.2	E230M 1978 A	BUFFER-TIME=23 7			2000 Secs (2000 Secs) [==>]	[2]

