



# 15081 - Revealing the circum-nuclear torus: HST imaging of active galaxies observed during a Spitzer reverberation mapping campaign

Cycle: 25, Proposal Category: GO

(Availability Mode: SUPPORTED)

## INVESTIGATORS

<i>Name</i>	<i>Institution</i>	<i>E-Mail</i>
<b>Dr. Andrew Robinson (PI) (Contact)</b>	<b>Rochester Institute of Technology</b>	<b>axrsps@rit.edu</b>
Dr. Michael W. Richmond (CoI)	Rochester Institute of Technology	mwrps@rit.edu
Triana Almeyda (CoI) (ESA Member)	University of Southampton	tra3595@rit.edu
Dr. Billy Vazquez (CoI)	Rochester Institute of Technology	bxvsps@rit.edu

## VISITS

<i>Visit</i>	<i>Targets used in Visit</i>	<i>Configurations used in Visit</i>	<i>Orbits Used</i>	<i>Last Orbit Planner Run</i>	<i>OP Current with Visit?</i>
01	(1) NGC-6418	WFC3/UVIS	1	08-Sep-2017 20:01:38.0	yes
02	(2) IRAS17552+6209	WFC3/UVIS	1	08-Sep-2017 20:01:39.0	yes
03	(3) KAZ102	WFC3/UVIS	1	08-Sep-2017 20:01:40.0	yes
04	(4) KAZ163	WFC3/UVIS	1	08-Sep-2017 20:01:41.0	yes
05	(5) MRK-507	WFC3/UVIS	1	08-Sep-2017 20:01:42.0	yes
06	(6) MRK-876	WFC3/UVIS	1	08-Sep-2017 20:01:43.0	yes
07	(7) MRK-885	WFC3/UVIS	1	08-Sep-2017 20:01:44.0	yes
08	(8) UGC-10697	WFC3/UVIS	1	08-Sep-2017 20:01:45.0	yes

8 Total Orbits Used

## **ABSTRACT**

We are currently analyzing data from a recently completed ~2.5 year monitoring campaign, during which 12 low-redshift broad-line AGN were observed at 3.6 and 4.5 microns with the Spitzer Space Telescope, with supporting optical observations from several ground-based telescopes.

The objective is to "reverberation map" the circumnuclear torus of dusty molecular gas that is a key element of the AGN unification scheme; that is, infer its size and structure from the temporal response of the dusty torus IR emission to changes in the AGN optical luminosity. However, a critical unknown is the contribution of host galaxy starlight to the measured optical luminosity.

The objective of this proposal is to obtain WFC3/UVIS images of 8 of our Spitzer galaxies in order to decompose the host galaxy and AGN contributions within the photometric apertures used for the monitoring campaign. Removing the host galaxy contribution is an essential step in the analysis and interpretation of this unique time-series dataset, since it will allow the intrinsic luminosity and variability amplitude of the AGN optical continuum to be determined. This, in turn, will yield more precise measurements of the optical-IR lags and better estimates of the dust sublimation radius and undiluted optical light curves. These are essential for our torus reverberation simulations, since the amplitude of the luminosity variations can strongly modify the torus response through the effects of dust sublimation.

## **OBSERVING DESCRIPTION**

We propose to obtain WFC3/UVIS images of 8 nearby active galaxies observed during our Spitzer Space Telescope torus reverberation-mapping campaign, using the F621M filter. We will require a single orbit for each of the 8 targets.

The images will allow us to determine the constant host galaxy starlight contribution to the measured optical flux. For the redshift range spanned by our targets, the F621M filter samples the spectrum in a region which is free of strong emission lines, between the strong H $\beta$  and [OIII]4959, 5007 lines to the blue and H $\alpha$  + [NII]6548,83 lines to red, ensuring that the images will be dominated by continuum light. It is important, in particular, that the variable broad H $\alpha$  and H $\beta$  lines are excluded so that we can recover the constant host galaxy contribution. Note that after reviewing the filter pass bands, it was decided that F621M is a better choice for our targets than the F547M filter, which was selected for the phase I proposal.

As relatively large photometric apertures (5") were necessarily used for many of our ground-based measurements (with typical seeing  $\sim$ 1" and for some instruments, low angular resolution), the starlight contribution to the measured optical fluxes is substantial for all 8 AGNs, but it is not possible to accurately quantify this contribution using our existing data. Removing this host galaxy contribution to the measured fluxes is an essential step in the analysis and interpretation of this unique time-series dataset, since it will allow the intrinsic luminosity and variability amplitude of the AGN optical continuum to be determined. Our goal is to measure the integrated host starlight flux to  $\sim$ 10%, which requires the high-resolution and stable PSF of WFC3/UVIS images.

The observing strategy and analysis methodology adopted here follows that of Bentz et al. (2013, ApJ 767, 149; GO-11662). We will maximize the dynamic range of the data by obtaining two sequences of 3 exposures of approximately 40s, 400s and 800s for each of our targets. The short ( $\sim$ 40s) exposure is below the saturation point for all our targets as estimated by the ETC, while the 400s and 800s exposures will maximize the S/N of the host galaxy and the wings of the nuclear PSF. We will replace saturated pixels in and around the nucleus in the long exposure images using corresponding pixels from the shallower, unsaturated exposures, scaling the counts by the exposure time ratio. We will use a 2-point dither pattern to improve the WFC3 point spread function (PSF), with a sequence of 3 exposures being executed at each dither position. The short exposure times differ slightly between objects to ensure that the nuclear point sources in the brightest objects will not saturate. The target having the brightest nucleus is M876, for which  $B \sim 14.4$ . The ETC indicates a time to saturation of 49s. This is a lower limit, since we assumed that the nucleus emits all the light. However, to allow for possible variability we limited the exposure to 30s. We use 40 - 44s exposures for the remaining targets, which have  $B \sim 16-17$ .

The ETC indicates that the short, medium and long exposures require different post-flash levels to mitigate CTE losses. We therefore implement the dither pattern as two sets of individual exposures, with the second set having a POS-TARG offset of 0.099,0.106, equivalent to the standard WFC3 UVIS 2-point line dither pattern. We will use the UVIS2 aperture. As all our targets comfortably fit into the CCD 2 field of view, it is not necessary to perform a larger dither to fill in the chip gap. The exposures have been ordered so that the 668s and 352s buffer dumps occur in parallel with long

and intermediate exposures respectively.

On the recommendation of the contact scientist, we have adjusted the post flash level for each exposure so as to reach a background level of 15 electrons/pix to reduce CTE losses.

The GALFIT 2-D image decomposition software (Peng et al. 2002, 2010) will be used to model the surface brightness distribution of each target, in order to separate the host galaxy and AGN components. We will use TinyTim (Krist, 1993) to model the unresolved AGN PSF. Each target image also contains 2-4 field stars comparable in brightness to the AGN. These will be used to estimate color corrections and can also be combined to construct an alternative PSF model. The end product will be an intrinsic, host galaxy subtracted, light curve for each of the AGN in our sample.

Proposal 15081 - NGC6418 (01) - Revealing the circum-nuclear torus: HST imaging of active galaxies observed during a Spitzer rever...

Sat Sep 09 00:01:47 GMT 2017

<b>Visit</b>	<b>Proposal 15081, NGC6418 (01), scheduling</b> <b>Diagnostic Status: Warning</b> Scientific Instruments: WFC3/UVIS Special Requirements: (none)									
	(NGC6418 short, dither pos 1 (01.003)) Warning (Form): FLASH level may be too high for this exposure or a long subexposure. See extended explanation in the diagnostic browser (NGC6418 short, dither pos 2 (01.006)) Warning (Form): FLASH level may be too high for this exposure or a long subexposure. See extended explanation in the diagnostic browser									
<b>Diagnos</b>										
<b>Fixed Targets</b>	<b>#</b>	<b>Name</b>	<b>Target Coordinates</b>	<b>Targ. Coord. Corrections</b>	<b>Fluxes</b>	<b>Miscellaneous</b>				
	(1)	NGC-6418	RA: 17 38 9.3100 (264.5387917d) Dec: +58 42 53.60 (58.71489d) Equinox: J2000		V=16.84	Reference Frame: SIMBAD				
<i>Comments: This object was generated by the targetselector and retrieved from the SIMBAD database.</i> Extended=YES										
<b>Exposures</b>	<b>#</b>	<b>Label</b>	<b>Target</b>	<b>Config,Mode,Aperture</b>	<b>Spectral Els.</b>	<b>Opt. Params.</b>	<b>Special Reqs.</b>	<b>Groups</b>	<b>Exp. Time (Total)/[Actual Dur.]</b>	<b>Orbit</b>
	1	NGC6418 long, dither pos 1	(1) NGC-6418	WFC3/UVIS, ACCUM, UVIS2	F621M	FLASH=3	POS TARG 0.0,0.0		800 Secs (800 Secs)	
									[==>]	[1]
	2	NGC6418 med, dither pos 1	(1) NGC-6418	WFC3/UVIS, ACCUM, UVIS2	F621M	FLASH=10	POS TARG 0.0,0.0		376 Secs (376 Secs)	
									[==>]	[1]
	3	NGC6418 short, dither pos 1	(1) NGC-6418	WFC3/UVIS, ACCUM, UVIS2	F621M	FLASH=15	POS TARG 0.0,0.0		43 Secs (43 Secs)	
									[==>]	[1]
	4	NGC6418 long, dither pos 2	(1) NGC-6418	WFC3/UVIS, ACCUM, UVIS2	F621M	FLASH=3	POS TARG 0.099,0.106		800 Secs (800 Secs)	
								[==>]	[1]	
5	NGC6418 med, dither pos 2	(1) NGC-6418	WFC3/UVIS, ACCUM, UVIS2	F621M	FLASH=10	POS TARG 0.099,0.106		376 Secs (376 Secs)		
								[==>]	[1]	
6	NGC6418 short, dither pos 2	(1) NGC-6418	WFC3/UVIS, ACCUM, UVIS2	F621M	FLASH=15	POS TARG 0.099,0.106		43 Secs (43 Secs)		
								[==>]	[1]	

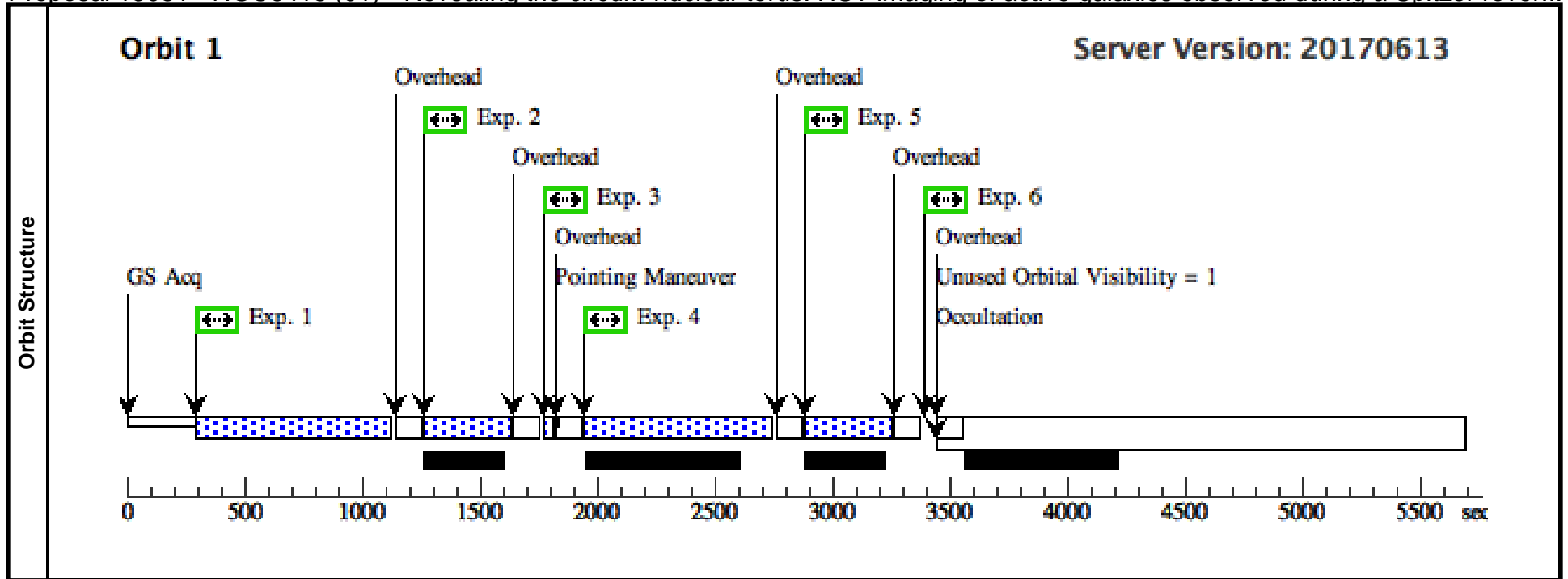

Proposal 15081 - IRAS17552 (02) - Revealing the circum-nuclear torus: HST imaging of active galaxies observed during a Spitzer rev...

Sat Sep 09 00:01:47 GMT 2017

<b>Visit</b>	<b>Proposal 15081, IRAS17552 (02), scheduling</b> <b>Diagnostic Status: Warning</b> Scientific Instruments: WFC3/UVIS Special Requirements: (none)									
	(IRAS17552 short, dither pos 1 (02.003)) Warning (Form): FLASH level may be too high for this exposure or a long subexposure. See extended explanation in the diagnostic browser (IRAS17552 short, dither pos 2 (02.006)) Warning (Form): FLASH level may be too high for this exposure or a long subexposure. See extended explanation in the diagnostic browser									
<b>Diagnosics</b>										
<b>Fixed Targets</b>	<b>#</b>	<b>Name</b>	<b>Target Coordinates</b>	<b>Targ. Coord. Corrections</b>	<b>Fluxes</b>	<b>Miscellaneous</b>				
	(2)	IRAS17552+6209	RA: 17 55 40.4590 (268.9185792d) Dec: +62 09 40.63 (62.16129d) Equinox: J2000		V=15.0	Reference Frame: SIMBAD				
<i>Comments: This object was generated by the targetselector and retrieved from the SIMBAD database. Extended=YES</i>										
<b>Exposures</b>	<b>#</b>	<b>Label</b>	<b>Target</b>	<b>Config,Mode,Aperture</b>	<b>Spectral Els.</b>	<b>Opt. Params.</b>	<b>Special Reqs.</b>	<b>Groups</b>	<b>Exp. Time (Total)/[Actual Dur.]</b>	<b>Orbit</b>
	1	IRAS17552 long, dither pos 1	(2) IRAS17552+6209 9	WFC3/UVIS, ACCUM, UVIS2	F621M	FLASH=3	POS TARG 0.0,0.0		800 Secs (800 Secs) [==>]	[1]
	2	IRAS17552 med, dither pos 1	(2) IRAS17552+6209 9	WFC3/UVIS, ACCUM, UVIS2	F621M	FLASH=10	POS TARG 0.0,0.0		386 Secs (386 Secs) [==>]	[1]
	3	IRAS17552 short, dither pos 1	(2) IRAS17552+6209 9	WFC3/UVIS, ACCUM, UVIS2	F621M	FLASH=15	POS TARG 0.0,0.0		44 Secs (44 Secs) [==>]	[1]
	4	IRAS17552 long, dither pos 2	(2) IRAS17552+6209 9	WFC3/UVIS, ACCUM, UVIS2	F621M	FLASH=3	POS TARG 0.099,0.106		800 Secs (800 Secs) [==>]	[1]
	5	IRAS17552 med, dither pos 2	(2) IRAS17552+6209 9	WFC3/UVIS, ACCUM, UVIS2	F621M	FLASH=10	POS TARG 0.099,0.106		386 Secs (386 Secs) [==>]	[1]
	6	IRAS17552 short, dither pos 2	(2) IRAS17552+6209 9	WFC3/UVIS, ACCUM, UVIS2	F621M	FLASH=15	POS TARG 0.099,0.106		44 Secs (44 Secs) [==>]	[1]

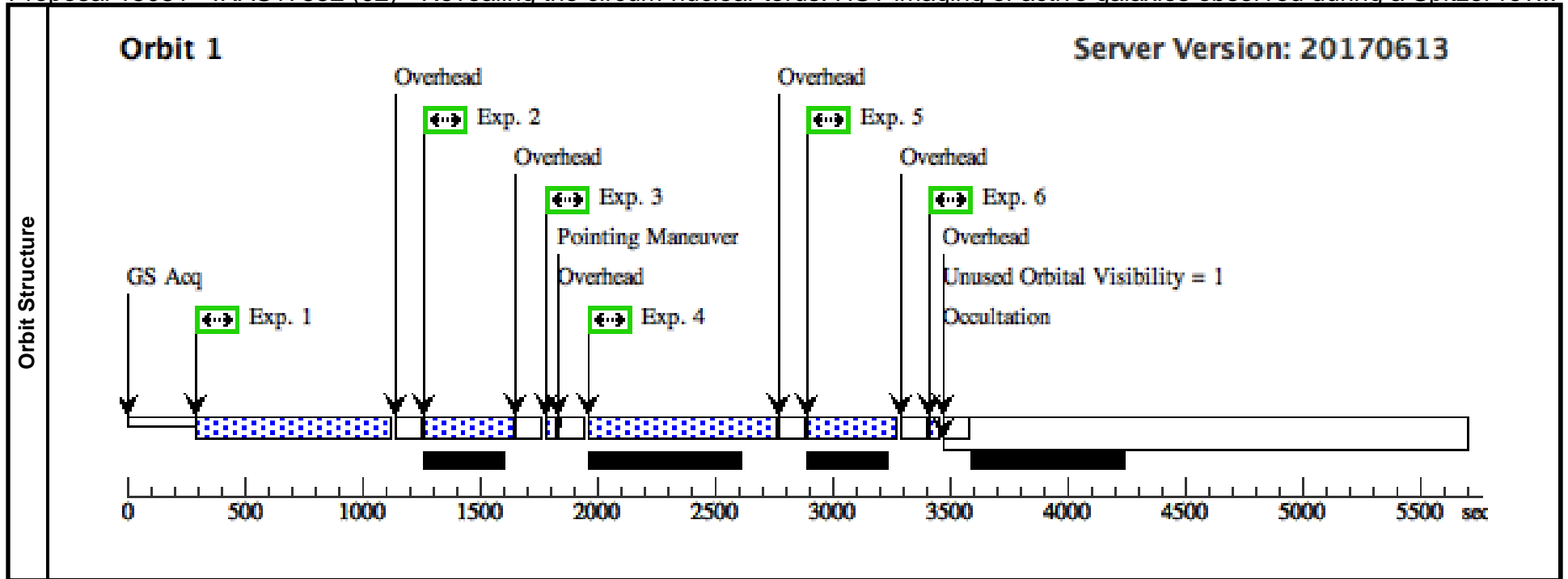

Proposal 15081 - KAZ 102 (03) - Revealing the circum-nuclear torus: HST imaging of active galaxies observed during a Spitzer reverb...

Sat Sep 09 00:01:47 GMT 2017

<b>Visit</b>	<b>Proposal 15081, KAZ 102 (03), scheduling</b> <b>Diagnostic Status: Warning</b> Scientific Instruments: WFC3/UVIS Special Requirements: (none)									
	(KAZ102 short, dither pos 1 (03.003)) Warning (Form): FLASH level may be too high for this exposure or a long subexposure. See extended explanation in the diagnostic browser (KAZ102 short, dither pos 2 (03.006)) Warning (Form): FLASH level may be too high for this exposure or a long subexposure. See extended explanation in the diagnostic browser									
<b>Diagnosics</b>										
<b>Fixed Targets</b>	<b>#</b>	<b>Name</b>	<b>Target Coordinates</b>	<b>Targ. Coord. Corrections</b>	<b>Fluxes</b>	<b>Miscellaneous</b>				
	(3)	KAZ102	RA: 18 03 28.9037 (270.8704321d) Dec: +67 38 10.53 (67.63626d) Equinox: J2000		V=15.78	Reference Frame: SIMBAD				
<i>Comments: This object was generated by the targetselector and retrieved from the SIMBAD database. Extended=YES</i>										
<b>Exposures</b>	<b>#</b>	<b>Label</b>	<b>Target</b>	<b>Config,Mode,Aperture</b>	<b>Spectral Els.</b>	<b>Opt. Params.</b>	<b>Special Reqs.</b>	<b>Groups</b>	<b>Exp. Time (Total)/[Actual Dur.]</b>	<b>Orbit</b>
	1	KAZ102 long, dither pos 1	(3) KAZ102	WFC3/UVIS, ACCUM, UVIS2	F621M	FLASH=3	POS TARG 0.0,0.0		800 Secs (800 Secs) [==>]	[1]
	2	KAZ102 med, dither pos 1	(3) KAZ102	WFC3/UVIS, ACCUM, UVIS2	F621M	FLASH=8	POS TARG 0.0,0.0		428 Secs (428 Secs) [==>]	[1]
	3	KAZ102 short, dither pos 1	(3) KAZ102	WFC3/UVIS, ACCUM, UVIS2	F621M	FLASH=15	POS TARG 0.0,0.0		40 Secs (40 Secs) [==>]	[1]
	4	KAZ102 long, dither pos 2	(3) KAZ102	WFC3/UVIS, ACCUM, UVIS2	F621M	FLASH=3	POS TARG 0.099,0.106		800 Secs (800 Secs) [==>]	[1]
	5	KAZ102 med, dither pos 2	(3) KAZ102	WFC3/UVIS, ACCUM, UVIS2	F621M	FLASH=8	POS TARG 0.099,0.106		428 Secs (428 Secs) [==>]	[1]
	6	KAZ102 short, dither pos 2	(3) KAZ102	WFC3/UVIS, ACCUM, UVIS2	F621M	FLASH=15	POS TARG 0.099,0.106		40 Secs (40 Secs) [==>]	[1]

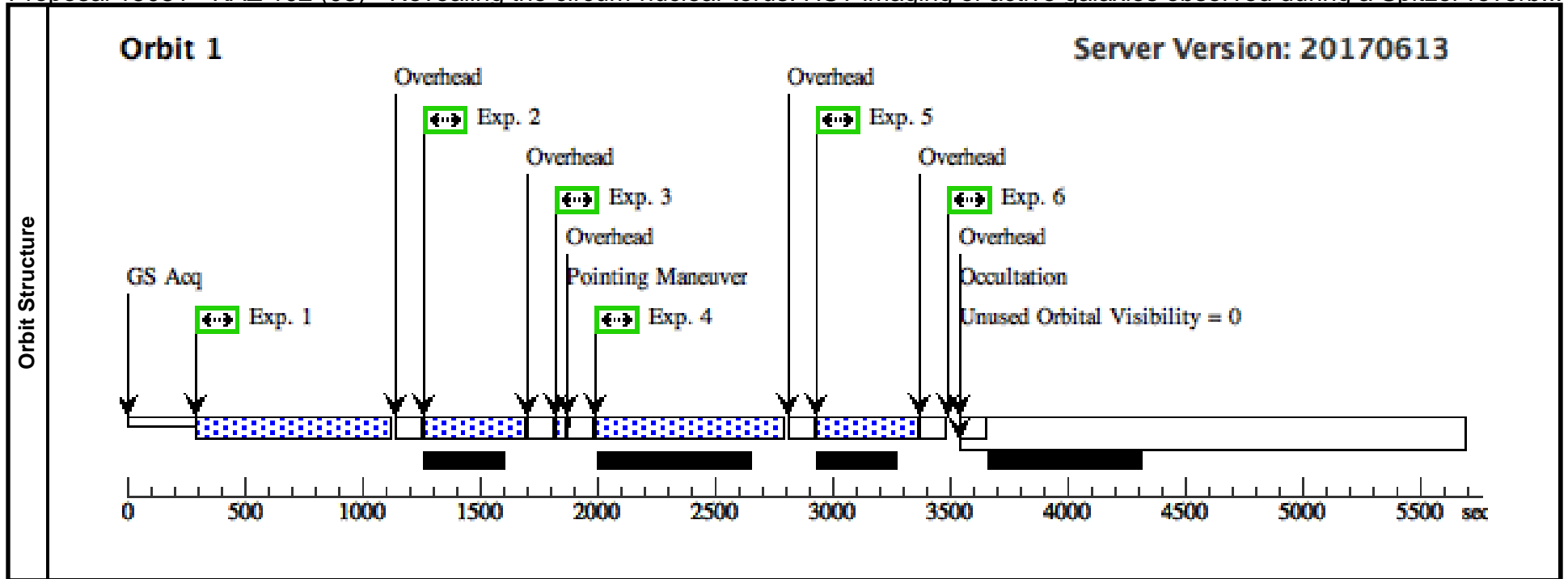

Proposal 15081 - KAZ 163 (04) - Revealing the circum-nuclear torus: HST imaging of active galaxies observed during a Spitzer reverb...

Sat Sep 09 00:01:47 GMT 2017

<b>Visit</b>	<b>Proposal 15081, KAZ 163 (04), scheduling</b> <b>Diagnostic Status: Warning</b> Scientific Instruments: WFC3/UVIS Special Requirements: (none)									
	(KAZ163 short, dither pos 1 (04.003)) Warning (Form): FLASH level may be too high for this exposure or a long subexposure. See extended explanation in the diagnostic browser (KAZ163 short, dither pos 2 (04.006)) Warning (Form): FLASH level may be too high for this exposure or a long subexposure. See extended explanation in the diagnostic browser									
<b>Diagnosics</b>										
<b>Fixed Targets</b>	<b>#</b>	<b>Name</b>	<b>Target Coordinates</b>	<b>Targ. Coord. Corrections</b>	<b>Fluxes</b>	<b>Miscellaneous</b>				
	(4)	KAZ163	RA: 17 46 59.9410 (266.7497542d) Dec: +68 36 39.22 (68.61089d) Equinox: J2000		V=15.01	Reference Frame: SIMBAD				
<i>Comments: This object was generated by the targetselector and retrieved from the SIMBAD database. Extended=YES</i>										
<b>Exposures</b>	<b>#</b>	<b>Label</b>	<b>Target</b>	<b>Config,Mode,Aperture</b>	<b>Spectral Els.</b>	<b>Opt. Params.</b>	<b>Special Reqs.</b>	<b>Groups</b>	<b>Exp. Time (Total)/[Actual Dur.]</b>	<b>Orbit</b>
	1	KAZ163 long, dither pos 1	(4) KAZ163	WFC3/UVIS, ACCUM, UVIS2	F621M	FLASH=3	POS TARG 0.0,0.0		800 Secs (800 Secs) [==>]	[1]
	2	KAZ163 med, dither pos 1	(4) KAZ163	WFC3/UVIS, ACCUM, UVIS2	F621M	FLASH=8	POS TARG 0.0,0.0		428 Secs (428 Secs) [==>]	[1]
	3	KAZ163 short, dither pos 1	(4) KAZ163	WFC3/UVIS, ACCUM, UVIS2	F621M	FLASH=15	POS TARG 0.0,0.0		40 Secs (40 Secs) [==>]	[1]
	4	KAZ163 long, dither pos 2	(4) KAZ163	WFC3/UVIS, ACCUM, UVIS2	F621M	FLASH=3	POS TARG 0.099,0.106		800 Secs (800 Secs) [==>]	[1]
	5	KAZ163 med, dither pos 2	(4) KAZ163	WFC3/UVIS, ACCUM, UVIS2	F621M	FLASH=8	POS TARG 0.099,0.106		428 Secs (428 Secs) [==>]	[1]
	6	KAZ163 short, dither pos 2	(4) KAZ163	WFC3/UVIS, ACCUM, UVIS2	F621M	FLASH=15	POS TARG 0.099,0.106		40 Secs (40 Secs) [==>]	[1]

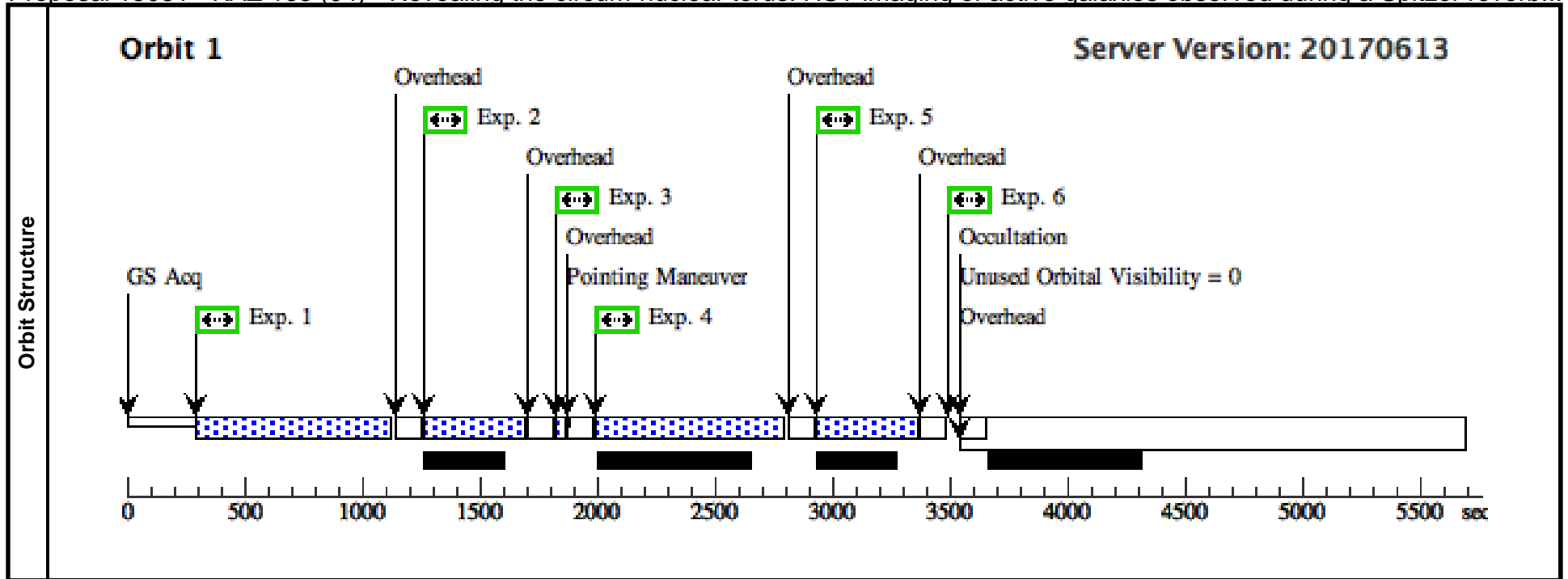

Proposal 15081 - MRK 507 (05) - Revealing the circum-nuclear torus: HST imaging of active galaxies observed during a Spitzer rever...

Sat Sep 09 00:01:47 GMT 2017

<b>Visit</b>	<b>Proposal 15081, MRK 507 (05), scheduling</b> <b>Diagnostic Status: Warning</b> Scientific Instruments: WFC3/UVIS Special Requirements: (none)									
	(MRK507 short, dither pos 1 (05.003)) Warning (Form): FLASH level may be too high for this exposure or a long subexposure. See extended explanation in the diagnostic browser (MRK507 short, dither pos 2 (05.006)) Warning (Form): FLASH level may be too high for this exposure or a long subexposure. See extended explanation in the diagnostic browser									
<b>Diagnos</b>										
<b>Fixed Targets</b>	<b>#</b>	<b>Name</b>	<b>Target Coordinates</b>	<b>Targ. Coord. Corrections</b>	<b>Fluxes</b>	<b>Miscellaneous</b>				
	(5)	MRK-507	RA: 17 48 38.4230 (267.1600958d) Dec: +68 42 16.06 (68.70446d) Equinox: J2000		V=15.45	Reference Frame: SIMBAD				
<i>Comments: This object was generated by the targetselector and retrieved from the SIMBAD database.</i> Extended=YES										
<b>Exposures</b>	<b>#</b>	<b>Label</b>	<b>Target</b>	<b>Config,Mode,Aperture</b>	<b>Spectral Els.</b>	<b>Opt. Params.</b>	<b>Special Reqs.</b>	<b>Groups</b>	<b>Exp. Time (Total)/[Actual Dur.]</b>	<b>Orbit</b>
	1	MRK507 long, dither pos 1	(5) MRK-507	WFC3/UVIS, ACCUM, UVIS2	F621M	FLASH=3	POS TARG 0.0,0.0		800 Secs (800 Secs) [==>]	[1]
	2	MRK507 med, dither pos 1	(5) MRK-507	WFC3/UVIS, ACCUM, UVIS2	F621M	FLASH=8	POS TARG 0.0,0.0		428 Secs (428 Secs) [==>]	[1]
	3	MRK507 short, dither pos 1	(5) MRK-507	WFC3/UVIS, ACCUM, UVIS2	F621M	FLASH=15	POS TARG 0.0,0.0		40 Secs (40 Secs) [==>]	[1]
	4	MRK507 long, dither pos 2	(5) MRK-507	WFC3/UVIS, ACCUM, UVIS2	F621M	FLASH=3	POS TARG 0.099,0.106		800 Secs (800 Secs) [==>]	[1]
	5	MRK507 med, dither pos 2	(5) MRK-507	WFC3/UVIS, ACCUM, UVIS2	F621M	FLASH=8	POS TARG 0.099,0.106		428 Secs (428 Secs) [==>]	[1]
	6	MRK507 short, dither pos 2	(5) MRK-507	WFC3/UVIS, ACCUM, UVIS2	F621M	FLASH=15	POS TARG 0.099,0.106		40 Secs (40 Secs) [==>]	[1]

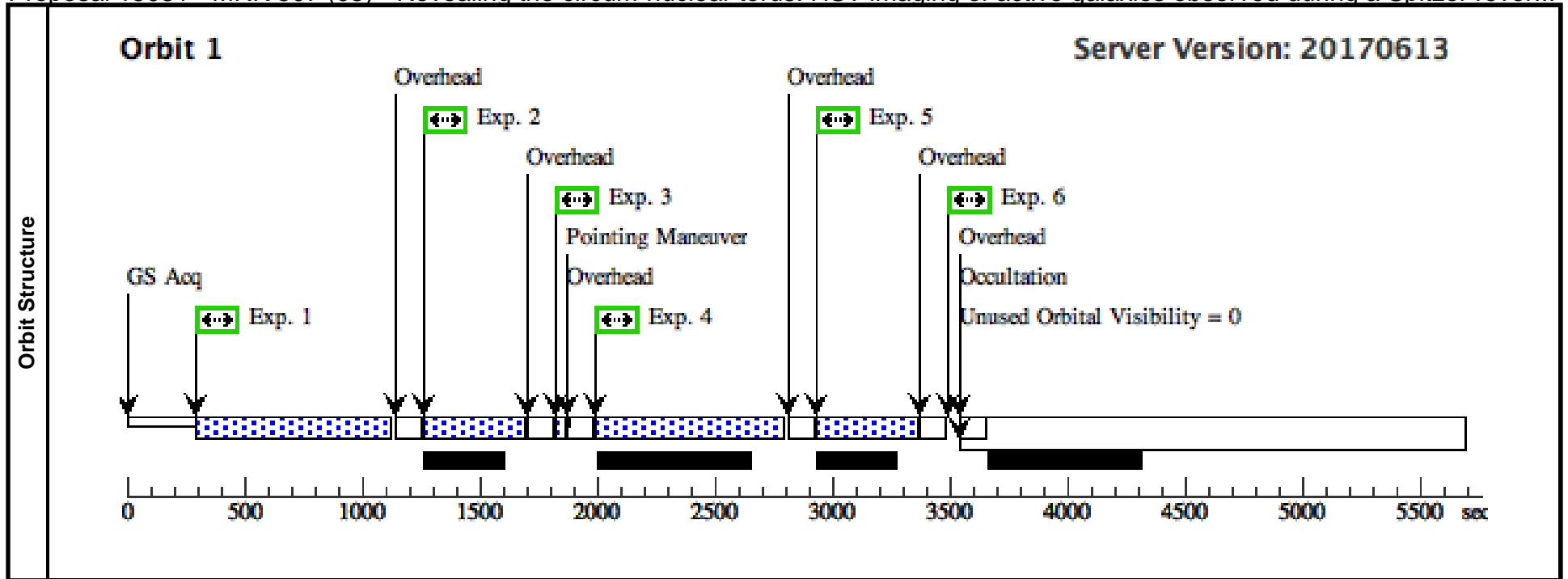

Proposal 15081 - MRK 876 (06) - Revealing the circum-nuclear torus: HST imaging of active galaxies observed during a Spitzer rever...

Sat Sep 09 00:01:47 GMT 2017

Visit	<b>Proposal 15081, MRK 876 (06), scheduling</b> <b>Diagnostic Status: Warning</b> Scientific Instruments: WFC3/UVIS Special Requirements: (none)									
	Diagnostics	(MRK876 short, dither pos 1 (06.003)) Warning (Form): FLASH level may be too high for this exposure or a long subexposure. See extended explanation in the diagnostic browser (MRK876 short, dither pos 2 (06.006)) Warning (Form): FLASH level may be too high for this exposure or a long subexposure. See extended explanation in the diagnostic browser								
Fixed Targets		#	Name	Target Coordinates	Targ. Coord. Corrections	Fluxes	Miscellaneous			
		(6)	MRK-876	RA: 16 13 57.2067 (243.4883612d) Dec: +65 43 10.67 (65.71963d) Equinox: J2000		V=15.49	Reference Frame: SIMBAD			
	<i>Comments: This object was generated by the targetselector and retrieved from the SIMBAD database.</i> Extended=YES									
Exposures	#	Label	Target	Config,Mode,Aperture	Spectral Els.	Opt. Params.	Special Reqs.	Groups	Exp. Time (Total)/[Actual Dur.]	Orbit
	1	MRK876 long, dither pos 1	(6) MRK-876	WFC3/UVIS, ACCUM, UVIS2	F621M	FLASH=3	POS TARG 0.0,0.0		810 Secs (810 Secs)	
									[==>]	[1]
	2	MRK876 med, dither pos 1	(6) MRK-876	WFC3/UVIS, ACCUM, UVIS2	F621M	FLASH=8	POS TARG 0.0,0.0		428 Secs (428 Secs)	
									[==>]	[1]
	3	MRK876 short, dither pos 1	(6) MRK-876	WFC3/UVIS, ACCUM, UVIS2	F621M	FLASH=15	POS TARG 0.0,0.0		30 Secs (30 Secs)	
									[==>]	[1]
	4	MRK876 long, dither pos 2	(6) MRK-876	WFC3/UVIS, ACCUM, UVIS2	F621M	FLASH=3	POS TARG 0.099,0.106		810 Secs (810 Secs)	
								[==>]	[1]	
5	MRK876 med, dither pos 2	(6) MRK-876	WFC3/UVIS, ACCUM, UVIS2	F621M	FLASH=8	POS TARG 0.099,0.106		428 Secs (428 Secs)		
								[==>]	[1]	
6	MRK876 short, dither pos 2	(6) MRK-876	WFC3/UVIS, ACCUM, UVIS2	F621M	FLASH=15	POS TARG 0.099,0.106		30 Secs (30 Secs)		
								[==>]	[1]	

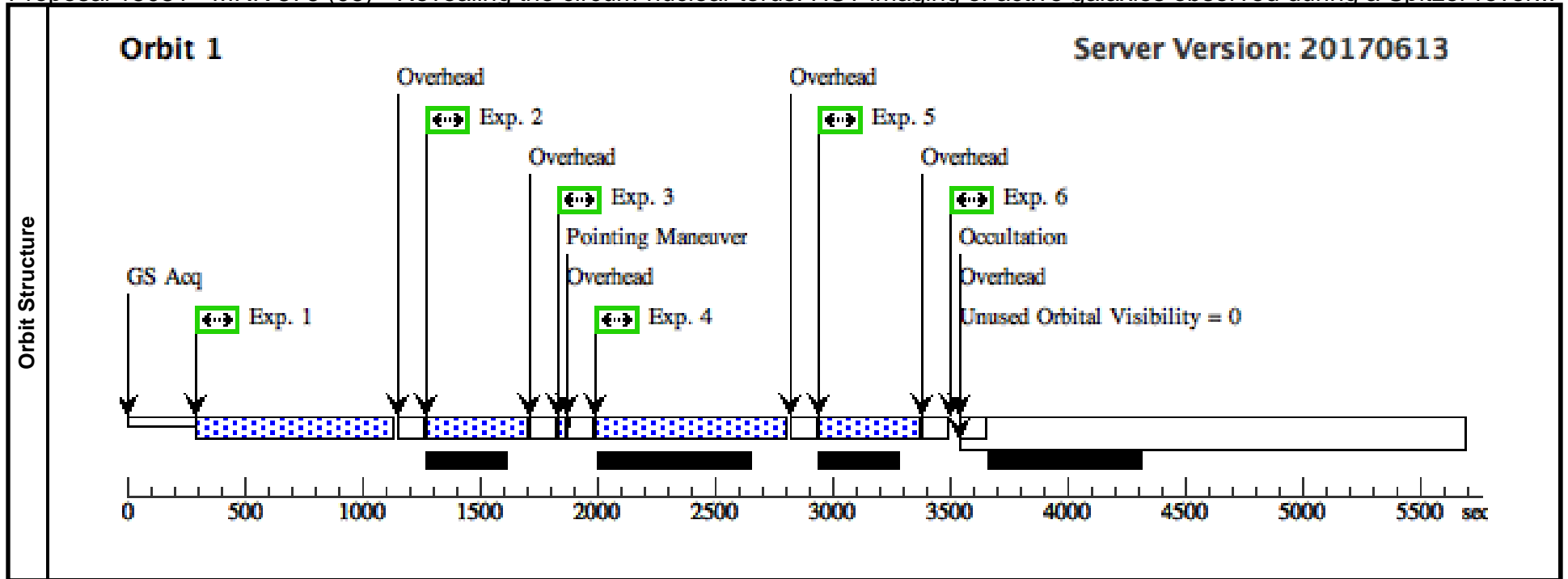

Proposal 15081 - MRK 885 (07) - Revealing the circum-nuclear torus: HST imaging of active galaxies observed during a Spitzer rever...

Sat Sep 09 00:01:47 GMT 2017

<b>Visit</b>	<b>Proposal 15081, MRK 885 (07), implementation</b> <b>Diagnostic Status: Warning</b> Scientific Instruments: WFC3/UVIS Special Requirements: ORIENT 15D TO 40 D; ORIENT 60D TO 130 D; ORIENT 150D TO 175 D; ORIENT 195D TO 220 D; ORIENT 240D TO 310 D; ORIENT 330D TO 355 D <i>Comments: Orientation ranges defined to avoid bleeding and diffraction spikes from bright star at PA ~ 230, ~20 arcsec from target.</i>																																																																														
	(MRK885 short, dither pos 1 (07.003)) Warning (Form): FLASH level may be too high for this exposure or a long subexposure. See extended explanation in the diagnostic browser (MRK885 short, dither pos 2 (07.006)) Warning (Form): FLASH level may be too high for this exposure or a long subexposure. See extended explanation in the diagnostic browser																																																																														
<b>Diagnos</b>																																																																															
<b>Fixed Targets</b>	<table border="1"> <thead> <tr> <th>#</th> <th>Name</th> <th>Target Coordinates</th> <th>Targ. Coord. Corrections</th> <th>Fluxes</th> <th>Miscellaneous</th> </tr> </thead> <tbody> <tr> <td>(7)</td> <td>MRK-885</td> <td>RA: 16 29 48.3140 (247.4513083d) Dec: +67 22 41.87 (67.37830d) Equinox: J2000</td> <td></td> <td>V=14.56</td> <td>Reference Frame: SIMBAD</td> </tr> </tbody> </table>	#	Name	Target Coordinates	Targ. Coord. Corrections	Fluxes	Miscellaneous	(7)	MRK-885	RA: 16 29 48.3140 (247.4513083d) Dec: +67 22 41.87 (67.37830d) Equinox: J2000		V=14.56	Reference Frame: SIMBAD	<i>Comments: This object was generated by the targetselector and retrieved from the SIMBAD database. Extended=YES</i>																																																																	
	#	Name	Target Coordinates	Targ. Coord. Corrections	Fluxes	Miscellaneous																																																																									
(7)	MRK-885	RA: 16 29 48.3140 (247.4513083d) Dec: +67 22 41.87 (67.37830d) Equinox: J2000		V=14.56	Reference Frame: SIMBAD																																																																										
<b>Exposures</b>	<table border="1"> <thead> <tr> <th>#</th> <th>Label</th> <th>Target</th> <th>Config,Mode,Aperture</th> <th>Spectral Els.</th> <th>Opt. Params.</th> <th>Special Reqs.</th> <th>Groups</th> <th>Exp. Time (Total)/[Actual Dur.]</th> <th>Orbit</th> </tr> </thead> <tbody> <tr> <td>1</td> <td>MRK885 long, dither pos 1</td> <td>(7) MRK-885</td> <td>WFC3/UVIS, ACCUM, UVIS2</td> <td>F621M</td> <td>FLASH=3</td> <td>POS TARG 0.0,0.0</td> <td></td> <td>800 Secs (800 Secs) [==&gt;]</td> <td>[1]</td> </tr> <tr> <td>2</td> <td>MRK885 med, dither pos 1</td> <td>(7) MRK-885</td> <td>WFC3/UVIS, ACCUM, UVIS2</td> <td>F621M</td> <td>FLASH=8</td> <td>POS TARG 0.0,0.0</td> <td></td> <td>428 Secs (428 Secs) [==&gt;]</td> <td>[1]</td> </tr> <tr> <td>3</td> <td>MRK885 short, dither pos 1</td> <td>(7) MRK-885</td> <td>WFC3/UVIS, ACCUM, UVIS2</td> <td>F621M</td> <td>FLASH=15</td> <td>POS TARG 0.0,0.0</td> <td></td> <td>40 Secs (40 Secs) [==&gt;]</td> <td>[1]</td> </tr> <tr> <td>4</td> <td>MRK885 long, dither pos 2</td> <td>(7) MRK-885</td> <td>WFC3/UVIS, ACCUM, UVIS2</td> <td>F621M</td> <td>FLASH=3</td> <td>POS TARG 0.099,0.106</td> <td></td> <td>800 Secs (800 Secs) [==&gt;]</td> <td>[1]</td> </tr> <tr> <td>5</td> <td>MRK885 med, dither pos 2</td> <td>(7) MRK-885</td> <td>WFC3/UVIS, ACCUM, UVIS2</td> <td>F621M</td> <td>FLASH=8</td> <td>POS TARG 0.099,0.106</td> <td></td> <td>428 Secs (428 Secs) [==&gt;]</td> <td>[1]</td> </tr> <tr> <td>6</td> <td>MRK885 short, dither pos 2</td> <td>(7) MRK-885</td> <td>WFC3/UVIS, ACCUM, UVIS2</td> <td>F621M</td> <td>FLASH=15</td> <td>POS TARG 0.099,0.106</td> <td></td> <td>40 Secs (40 Secs) [==&gt;]</td> <td>[1]</td> </tr> </tbody> </table>									#	Label	Target	Config,Mode,Aperture	Spectral Els.	Opt. Params.	Special Reqs.	Groups	Exp. Time (Total)/[Actual Dur.]	Orbit	1	MRK885 long, dither pos 1	(7) MRK-885	WFC3/UVIS, ACCUM, UVIS2	F621M	FLASH=3	POS TARG 0.0,0.0		800 Secs (800 Secs) [==>]	[1]	2	MRK885 med, dither pos 1	(7) MRK-885	WFC3/UVIS, ACCUM, UVIS2	F621M	FLASH=8	POS TARG 0.0,0.0		428 Secs (428 Secs) [==>]	[1]	3	MRK885 short, dither pos 1	(7) MRK-885	WFC3/UVIS, ACCUM, UVIS2	F621M	FLASH=15	POS TARG 0.0,0.0		40 Secs (40 Secs) [==>]	[1]	4	MRK885 long, dither pos 2	(7) MRK-885	WFC3/UVIS, ACCUM, UVIS2	F621M	FLASH=3	POS TARG 0.099,0.106		800 Secs (800 Secs) [==>]	[1]	5	MRK885 med, dither pos 2	(7) MRK-885	WFC3/UVIS, ACCUM, UVIS2	F621M	FLASH=8	POS TARG 0.099,0.106		428 Secs (428 Secs) [==>]	[1]	6	MRK885 short, dither pos 2	(7) MRK-885	WFC3/UVIS, ACCUM, UVIS2	F621M	FLASH=15	POS TARG 0.099,0.106		40 Secs (40 Secs) [==>]	[1]
	#	Label	Target	Config,Mode,Aperture	Spectral Els.	Opt. Params.	Special Reqs.	Groups	Exp. Time (Total)/[Actual Dur.]	Orbit																																																																					
1	MRK885 long, dither pos 1	(7) MRK-885	WFC3/UVIS, ACCUM, UVIS2	F621M	FLASH=3	POS TARG 0.0,0.0		800 Secs (800 Secs) [==>]	[1]																																																																						
2	MRK885 med, dither pos 1	(7) MRK-885	WFC3/UVIS, ACCUM, UVIS2	F621M	FLASH=8	POS TARG 0.0,0.0		428 Secs (428 Secs) [==>]	[1]																																																																						
3	MRK885 short, dither pos 1	(7) MRK-885	WFC3/UVIS, ACCUM, UVIS2	F621M	FLASH=15	POS TARG 0.0,0.0		40 Secs (40 Secs) [==>]	[1]																																																																						
4	MRK885 long, dither pos 2	(7) MRK-885	WFC3/UVIS, ACCUM, UVIS2	F621M	FLASH=3	POS TARG 0.099,0.106		800 Secs (800 Secs) [==>]	[1]																																																																						
5	MRK885 med, dither pos 2	(7) MRK-885	WFC3/UVIS, ACCUM, UVIS2	F621M	FLASH=8	POS TARG 0.099,0.106		428 Secs (428 Secs) [==>]	[1]																																																																						
6	MRK885 short, dither pos 2	(7) MRK-885	WFC3/UVIS, ACCUM, UVIS2	F621M	FLASH=15	POS TARG 0.099,0.106		40 Secs (40 Secs) [==>]	[1]																																																																						

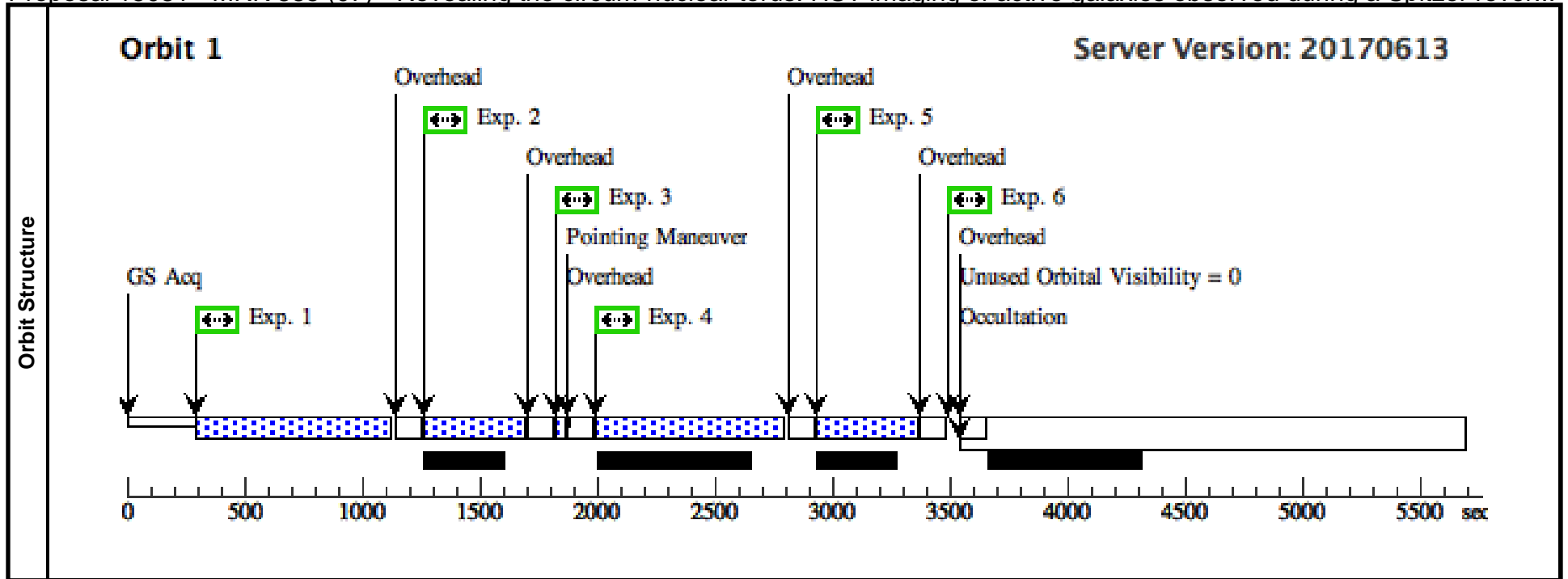

Proposal 15081 - UGC 10697 (08) - Revealing the circum-nuclear torus: HST imaging of active galaxies observed during a Spitzer rev...

Sat Sep 09 00:01:47 GMT 2017

<b>Visit</b>	<b>Proposal 15081, UGC 10697 (08), scheduling</b> <b>Diagnostic Status: Warning</b> Scientific Instruments: WFC3/UVIS Special Requirements: (none)									
	(UGC10697 short, dither pos 1 (08.003)) Warning (Form): FLASH level may be too high for this exposure or a long subexposure. See extended explanation in the diagnostic browser (UGC10697 short, dither pos 2 (08.006)) Warning (Form): FLASH level may be too high for this exposure or a long subexposure. See extended explanation in the diagnostic browser									
<b>Diagnos</b>										
<b>Fixed Targets</b>	<b>#</b>	<b>Name</b>	<b>Target Coordinates</b>	<b>Targ. Coord. Corrections</b>	<b>Fluxes</b>	<b>Miscellaneous</b>				
	(8)	UGC-10697	RA: 17 02 44.2310 (255.6842958d) Dec: +72 53 29.79 (72.89161d) Equinox: J2000		V=16.4	Reference Frame: SIMBAD				
<i>Comments: This object was generated by the targetselector and retrieved from the SIMBAD database.</i> Extended=YES										
<b>Exposures</b>	<b>#</b>	<b>Label</b>	<b>Target</b>	<b>Config,Mode,Aperture</b>	<b>Spectral Els.</b>	<b>Opt. Params.</b>	<b>Special Reqs.</b>	<b>Groups</b>	<b>Exp. Time (Total)/[Actual Dur.]</b>	<b>Orbit</b>
	1	UGC10697 1 ong, dither p os 1	(8) UGC-10697	WFC3/UVIS, ACCUM, UVIS2	F621M	FLASH=3	POS TARG 0.0,0.0		800 Secs (800 Secs) [==>]	[1]
	2	UGC10697 med, dither pos 1	(8) UGC-10697	WFC3/UVIS, ACCUM, UVIS2	F621M	FLASH=8	POS TARG 0.0,0.0		447 Secs (447 Secs) [==>]	[1]
	3	UGC10697 short, dither pos 1	(8) UGC-10697	WFC3/UVIS, ACCUM, UVIS2	F621M	FLASH=15	POS TARG 0.0,0.0		40 Secs (40 Secs) [==>]	[1]
	4	UGC10697 1 ong, dither p os 2	(8) UGC-10697	WFC3/UVIS, ACCUM, UVIS2	F621M	FLASH=3	POS TARG 0.099,0.106		800 Secs (800 Secs) [==>]	[1]
	5	UGC10697 med, dither pos 2	(8) UGC-10697	WFC3/UVIS, ACCUM, UVIS2	F621M	FLASH=8	POS TARG 0.099,0.106		447 Secs (447 Secs) [==>]	[1]
	6	UGC10697 short, dither pos 2	(8) UGC-10697	WFC3/UVIS, ACCUM, UVIS2	F621M	FLASH=15	POS TARG 0.099,0.106		40 Secs (40 Secs) [==>]	[1]

