



15168 - The Nature of the Star-Grazing Bodies in a System at the Age of the Late Heavy Bombardment

Cycle: 25, Proposal Category: GO
(Availability Mode: SUPPORTED)

INVESTIGATORS

<i>Name</i>	<i>Institution</i>	<i>E-Mail</i>
Dr. Carol A. Grady (PI) (Contact)	Eureka Scientific Inc.	carol.a.grady@nasa.gov
Dr. Barry Y. Welsh (CoI)	Eureka Scientific Inc.	bwelsh@ssl.berkeley.edu
Dr. Alexander Brown (CoI)	University of Colorado at Boulder	alexander.brown@colorado.edu
Dr. Aki Roberge (CoI)	NASA Goddard Space Flight Center	aki.roberge@nasa.gov
Dr. Pablo Riviere Marichalar (CoI) (ESA Member)	Instituto de Ciencia de Materiales de Madrid	pablo.riviere.m@gmail.com
Dr. Carlos Eiroa (CoI) (ESA Member)	Universidad Autonoma de Madrid (UAM)	carlos.eiroa@uam.es
Dr. Eva Villaver (CoI) (ESA Member)	Universidad Autonoma de Madrid (UAM)	eva.villaver@uam.es
Isabel Rebollido (CoI) (ESA Member)	Universidad Autonoma de Madrid (UAM)	isabel.rebollido@uam.es

VISITS

<i>Visit</i>	<i>Targets used in Visit</i>	<i>Configurations used in Visit</i>	<i>Orbits Used</i>	<i>Last Orbit Planner Run</i>	<i>OP Current with Visit?</i>
01	(1) -PHI-LEO	STIS/CCD STIS/FUV-MAMA STIS/NUV-MAMA	4	18-Dec-2018 13:01:08.0	yes
02	(2) -ALF-CEP	STIS/CCD STIS/FUV-MAMA	1	18-Dec-2018 13:01:09.0	yes
03	(1) -PHI-LEO	COS/FUV	2	18-Dec-2018 13:01:10.0	yes

<i>Visit</i>	<i>Targets used in Visit</i>	<i>Configurations used in Visit</i>	<i>Orbits Used</i>	<i>Last Orbit Planner Run</i>	<i>OP Current with Visit?</i>
04	(1) -PHI-LEO	STIS/CCD STIS/FUV-MAMA STIS/NUV-MAMA	4	18-Dec-2018 13:01:12.0	yes
05	(1) -PHI-LEO	COS/FUV	2	18-Dec-2018 13:01:14.0	yes
51	(1) -PHI-LEO	STIS/CCD STIS/FUV-MAMA STIS/NUV-MAMA	4	18-Dec-2018 13:01:16.0	yes
53	(1) -PHI-LEO	COS/FUV	2	18-Dec-2018 13:01:17.0	yes
54	(1) -PHI-LEO	STIS/CCD STIS/FUV-MAMA STIS/NUV-MAMA	4	18-Dec-2018 13:01:20.0	yes
55	(1) -PHI-LEO	COS/FUV	2	18-Dec-2018 13:01:21.0	yes
56	(1) -PHI-LEO	STIS/CCD STIS/FUV-MAMA STIS/NUV-MAMA	4	18-Dec-2018 13:01:23.0	yes

29 Total Orbits Used

ABSTRACT

Studies of bodies exhibiting redshifted gaseous absorption features associated with star-grazing planetesimals offer unique data on the composition of the bodies, as well as the presence of planetesimal belt analogs and giant planets in systems throughout the stellar lifecycle. Studies of young systems, such as the A stars in the beta Pictoris moving group, suggest that the star grazing bodies contain abundant carbon and water dissociation products, indicating a cometary origin. A recent analysis of another system, phi Leo (A7 IV, age=400-900 Myr) shows similar infall features in Ca II and Ti II, with what may be a 15-year cycle. This system is similar in age to the Late Heavy Bombardment in our system, a time when terrestrial planets in our system are thought to have been veneered in organics and water. The available data indicate frequent infall events interpreted as transiting exo-comets, but sample only lithophile to super-refractory elements. Archival IUE data lack the FUV S/N to establish high carbon abundance or the presence of water dissociation products. We therefore seek COS and STIS spectra to sample the volatile gas dat, and constrain the origin of the star-grazing bodies. The FUV data will be augmented with NUV data sampling siderophiles and lithophiles.

OBSERVING DESCRIPTION

The Target: Phi Leo has archival IUE high dispersion spectra consistent with an A7 V star with $T_{\text{eff}}=7500$ K. Interstellar absorption (not seen in Ca II) is predicted to be at +1.75 km/s assuming that the star is at the centroid velocity for the Leo cloud (Redfield & Linsky 2008). At A7, $(B-V)_0=0.191$, so $E(B-V)=0.007$, and $N(\text{H}) = 2.52\text{E}19$. Given the uncertainty in spectral type, we scale integration times from our GO-13798 observations of HD 172555 by ΔV and assuming no extinction.

STIS TA: We will use F25ND5 for ACQ, and G430M, center 5471 for ACQ/PEAKUP.

STIS Spectral Observations: We propose obtaining a STIS G140M long-slit spectrum with central wavelength 1222 Å, to provide simultaneous measurement of airglow emission and circumstellar Lyman alpha. Scaling from HD 172555, this will require 4 ks or 2 orbits and will yield $S/N=2.5$ for the photosphere with chromospheric emission expected to be a factor of 2 above that. We will augment this observation with a STIS E140M observation providing coverage of Si II (2), C IV, Fe II 1608 Å. The S/N will be ~ 5 at 1543 assuming an F0V type, and >20 assuming A5V (STIS.sp.905753, STIS.sp.905752). We will also obtain 3 E230H segments, centered at 2762, 2513, and 1763 Å (STIS.sp.921476 for 2513 Å). Estimates were calculated using an A5V Kurucz model scaled to the peak continuum flux $3\text{E}-11$ erg cm^{-2} s^{-1} / Å seen in IUE LWP 27901 near 3000 Å, and are expected to be conservative since the spectral type is A7V. The longer wavelength exposures have warnings due to irregular variable count rate compared to global limit, which does not apply for a continuum source such as phi Leo with variable absorption. The 1763 setting has no warning for count rates. There are short buffer time warnings for the E230H exposures. The E230H observations will fit in the same orbit as acquisition and peakup observations. The E140M data will require 1 orbit, while the G140M needs 2 orbits.

COS TA: We will use an ACQ/SEARCH, ACQ/PEAKXD and ACQ/PEAKD.

COS Observations: We propose obtaining a COS G130M spectrum with the gap between the A and B segments set at 1291 Å, but plan to readout only the A segment, per operations at LP4. (COS.sp.92275). This will require at least 3.5 ks (2 orbits), but will provide coverage of O I, C I, C II and Si IV. The observation should be made during orbital night, ensuring minimal geocoronal contamination of O I and N I. If the star more closely resembles beta Pic, we anticipate $S/N=26$ (COS.sp.1007139), while if the star is closer to F0V, we expect $S/N=6.2$ in 2000 s, or 8.88 in 4000 s. Our COS observation will require 2 orbits each (COS.sp.92275) to yield photospheric S/N assuming A7V. We break the observations into 2 visits, STIS 4 orbits, and COS

Proposal 15168 (STScI Edit Number: 7, Created: Tuesday, December 18, 2018 at 1:01:24 PM Eastern Standard Time) - Overview

2 orbits with an after constraint to ensure that they are observed together. We request a second visit be scheduled 10 to 15 days after the first visit to permit us to assess variability in the transiting material.

Need for a spectral comparison object: We expect that, like Beta Pic and HD 172555, phi Leo will have chromospheric emission. For HD 172555, identification of emission in transitions of C II and O I required use of archival GHRS spectra as a photospheric model, and is particularly critical when the chromospheric emission distorts the blue wing of the line profile, but does not produce net emission in the observed spectrum. We currently lack suitable comparison object data at C IV, with alpha Cep as the comparison object, and O I. For coverage of the C IV region, we propose STIS G140M with a wavelength center of 1550 Å. Assuming an F0V Kurucz model for alpha Cep, we will achieve $18 < \text{SNR} < 26$ with no warnings in 900s (STIS.sp.905758). At O I, there is no moderate resolution GHRS data, and the archival GHRS G140L data are too coarsely sampled to provide a useful photospheric template. To cover O I, we propose obtaining a STIS G140M observation, centered at 13214 Å, and covering 1294-1348 Å. We obtain $S/N=30.7$ in 800s with no warnings and a peak count rate of 0.4c/s at 1345 Å [STIS.sp.901509]. The alpha Cep observations will add 1 orbit to our total orbit request, bringing our total orbit request to 13 orbits. The comparison object spectra can be used to interpret data for HD 172555 and beta Pic, HD 169142, and HD 32297 in addition to phi Leo.

Total Time Request: We request a total of 13 orbits for this program.

Scheduling Constraints: The COS G130M phi Leo observations should be carried out within 2 months of opposition to eliminate airglow contamination of N I and O I transitions. phi Leo has one visibility window during this period, from 28 Mar-25 April 2018. alpha Cep has numerous visibility windows throughout cycle 25.

Planned Analysis: COS data: We will first verify that all observing segments have no airglow contamination in the x1d spectral files, or obvious spectral variability. Absent variability, we will merge data from the individual FP-SPLIT settings into 1 spectrum per visit, binning as necessary. Our analysis will include: identification of the photospheric continuum using the comparison star data, fitting chromospheric emission with Gaussian profiles, and then normalization of the observed profiles by the photosphere+chromosphere, following our treatment of HD 172555.

STIS G140M/E140M: STIS G140M data centered at 1222 Å provides coverage of NI, Si III, and H I Lyman alpha, and using the 52x0.2" slit restricts airglow contamination to +/-40 km/s of the telluric value and offers sky data in the same observation. Our analysis will include a) search for emission in the pipeline processed but non-sky subtracted x2d spectrum, extract a sky spectrum and subtract the sky data from the source. Next we will follow studies of Lyman alpha profiles in nearby stars, model the line-of-sight N(H I) and corresponding extinction, search for asymmetric

Proposal 15168 (STScI Edit Number: 7, Created: Tuesday, December 18, 2018 at 1:01:24 PM Eastern Standard Time) - Overview
absorption wings (see Wilson et al. 2016), and place limits on the presence or absence of circumstellar H I absorption. An H I detection, in tandem with O I, would indicate that the star-grazing bodies in this system have water, and therefore resemble outer asteroid belt to cometary bodies. We will next search both the COS and STIS data for infalling N I features, if the S/N in the STIS data are sufficiently high. Their presence would indicate parent bodies with an origin in a putative Kuiper Belt analog, while the absence would be consistent with an origin in a warmer debris belt. The remainder of our analysis will follow studies of beta Pic and HD 172555. A byproduct of this analysis will be a more complete chromospheric to transition region line inventory for this system, and a study of the dependence of chromospheric emission on the stellar equatorial velocity.

Special Requirements: Wilson et al. (2016) demonstrated that observations made within 2 months of opposition result in no airglow contamination of COS G130M/PSA spectra at O I or N I, and minimize contamination of H I Lyman alpha. Opposition for phi Leo is in early March, so observations from January through early May would meet this requirement. There is one month-long visibility window for phi Leo 28 March-25 April 2018. We will make use of the BETWEEN special requirement to ensure that observations are made near opposition. Apart from that we will require that the COS and STIS G140M observations of phi Leo take place on back to back orbits using the AFTER special requirement. COS data will be taken in Time-Tag mode and using FP-SPLIT=4, but only with the single central wavelength.

Coordinated Observations: We will seek coordinated observations of phi Leo at Ca II, but these should not drive scheduling of the HST observations.

Justify Duplications: No duplications. phi Leo has no HST UV spectroscopy. alpha Cep has no moderate resolution data at O I or C IV.

BOT Concerns: Our science target, Phi Leo, is flagged as a health and safety concern under the assumption that its spectral type is 05V. IUE spectral data for the star clearly indicate that the spectral type is A7-8V with at most a small amount of extinction (<0.01 in $E(B-V)$). We expect a drop-off in flux similar to HD 172555 (5 orders of magnitude in flux shortward of 1800 Å). The long wavelength portion of this drop off can be seen in SWP 15504. This star is the brightest object in the field of view, by a large margin. It is not flagged as photometrically variable, and should present as a continuum source with variable absorption features.

Proposal 15168 - Visit 01 - The Nature of the Star-Grazing Bodies in a System at the Age of the Late Heavy Bombardment

Tue Dec 18 18:01:24 GMT 2018

Visit	Proposal 15168, Visit 01, failed Diagnostic Status: Warning Scientific Instruments: STIS/NUV-MAMA, STIS/CCD, STIS/FUV-MAMA Special Requirements: BETWEEN 10-JAN-2018 AND 10-MAY-2018																																																																																																													
	(Visit 01) Warning (Orbit Planner): ORBITAL VISIBILITY OVERRUN (Visit 01) Warning (Orbit Planner): ORBITAL VISIBILITY OVERRUN (Visit 01) Warning (Orbit Planner): ORBITAL VISIBILITY OVERRUN (Visit 01) Warning (Orbit Planner): ORBITAL VISIBILITY OVERRUN																																																																																																													
Fixed Targets	<table border="1"> <thead> <tr> <th>#</th> <th>Name</th> <th>Target Coordinates</th> <th>Targ. Coord. Corrections</th> <th>Fluxes</th> <th>Miscellaneous</th> </tr> </thead> <tbody> <tr> <td>(1)</td> <td>-PHI-LEO Alt Name1: HD-98058 Alt Name2: HIP-55084</td> <td>RA: 11 16 39.6996 (169.1654150d) Dec: -03 39 5.78 (-3.65161d) Equinox: J2000</td> <td>Proper Motion RA: -110.37 mas/yr Proper Motion Dec: -37.16 mas/yr Parallax: 0.01771" Epoch of Position: 2000 Radial Velocity: -3.0 km/sec</td> <td>V=4.45+/-0.009 F(2655)=3E-11 erg/cm/cm/s/A (IUE LWP 27899)</td> <td>Reference Frame: ICRS</td> </tr> </tbody> </table> <p><i>Comments: This object was generated by the targetselector and retrieved from the SIMBAD database.</i></p> <p><i>IUE data exist, for both the FUV and NUV, but large aperture data are available only in the NUV.</i></p> <p><i>Category=STAR</i></p> <p><i>Description=[A4-A9 V-IV, CIRCUMSTELLAR MATTER, CORONA, DISK, EXTRA-SOLAR PLANETARY SYSTEM]</i></p> <p><i>Extended=NO</i></p>										#	Name	Target Coordinates	Targ. Coord. Corrections	Fluxes	Miscellaneous	(1)	-PHI-LEO Alt Name1: HD-98058 Alt Name2: HIP-55084	RA: 11 16 39.6996 (169.1654150d) Dec: -03 39 5.78 (-3.65161d) Equinox: J2000	Proper Motion RA: -110.37 mas/yr Proper Motion Dec: -37.16 mas/yr Parallax: 0.01771" Epoch of Position: 2000 Radial Velocity: -3.0 km/sec	V=4.45+/-0.009 F(2655)=3E-11 erg/cm/cm/s/A (IUE LWP 27899)	Reference Frame: ICRS																																																																																								
	#	Name	Target Coordinates	Targ. Coord. Corrections	Fluxes	Miscellaneous																																																																																																								
(1)	-PHI-LEO Alt Name1: HD-98058 Alt Name2: HIP-55084	RA: 11 16 39.6996 (169.1654150d) Dec: -03 39 5.78 (-3.65161d) Equinox: J2000	Proper Motion RA: -110.37 mas/yr Proper Motion Dec: -37.16 mas/yr Parallax: 0.01771" Epoch of Position: 2000 Radial Velocity: -3.0 km/sec	V=4.45+/-0.009 F(2655)=3E-11 erg/cm/cm/s/A (IUE LWP 27899)	Reference Frame: ICRS																																																																																																									
Exposures	<table border="1"> <thead> <tr> <th>#</th> <th>Label (ETC Run)</th> <th>Target</th> <th>Config,Mode,Aperture</th> <th>Spectral Els.</th> <th>Opt. Params.</th> <th>Special Reqs.</th> <th>Groups</th> <th>Exp. Time (Total)/[Actual Dur.]</th> <th>Orbit</th> </tr> </thead> <tbody> <tr> <td>1</td> <td>(STIS.ta.100 5473)</td> <td>(1) -PHI-LEO</td> <td>STIS/CCD, ACQ, F25ND5</td> <td>MIRROR</td> <td></td> <td></td> <td></td> <td>1.5 Secs (1.5 Secs) [==>]</td> <td>[1]</td> </tr> <tr> <td>2</td> <td>(STIS.sp.10 05483)</td> <td>(1) -PHI-LEO</td> <td>STIS/CCD, ACQ/PEAK, 0.2X0.09</td> <td>G430M 5471 A</td> <td></td> <td></td> <td></td> <td>0.3 Secs (0.3 Secs) [==>]</td> <td>[1]</td> </tr> <tr> <td>3</td> <td>(STIS.sp.10 05483)</td> <td>(1) -PHI-LEO</td> <td>STIS/CCD, ACQ/PEAK, 0.1X0.03</td> <td>G430M 5471 A</td> <td></td> <td></td> <td></td> <td>0.3 Secs (0.3 Secs) [==>]</td> <td>[1]</td> </tr> <tr> <td>4</td> <td>(STIS.sp.10 05542)</td> <td>(1) -PHI-LEO</td> <td>STIS/NUV-MAMA, ACCUM, 0.1X0.03</td> <td>E230H 2762 A</td> <td></td> <td></td> <td></td> <td>190 Secs (190 Secs) [==>]</td> <td>[1]</td> </tr> <tr> <td>5</td> <td>(STIS.sp.10 05543)</td> <td>(1) -PHI-LEO</td> <td>STIS/NUV-MAMA, ACCUM, 0.1X0.03</td> <td>E230H 2513 A</td> <td></td> <td></td> <td></td> <td>199 Secs (199 Secs) [==>]</td> <td>[1]</td> </tr> <tr> <td>6</td> <td>(STIS.sp.10 05545)</td> <td>(1) -PHI-LEO</td> <td>STIS/NUV-MAMA, ACCUM, 0.1X0.03</td> <td>E230H 1763 A</td> <td></td> <td></td> <td></td> <td>199 Secs (199 Secs) [==>]</td> <td>[1]</td> </tr> <tr> <td>7</td> <td>(STIS.sp.90 5752)</td> <td>(1) -PHI-LEO</td> <td>STIS/FUV-MAMA, ACCUM, 0.2X0.2</td> <td>E140M 1425 A</td> <td></td> <td></td> <td></td> <td>2900 Secs (2900 Secs) [==>]</td> <td>[2]</td> </tr> <tr> <td>8</td> <td>(STIS.sp.90 5752)</td> <td>(1) -PHI-LEO</td> <td>STIS/FUV-MAMA, ACCUM, 52X0.2</td> <td>G140M 1222 A</td> <td></td> <td></td> <td></td> <td>2950 Secs (2950 Secs) [==>]</td> <td>[3]</td> </tr> <tr> <td>9</td> <td>(STIS.sp.10 06634)</td> <td>(1) -PHI-LEO</td> <td>STIS/FUV-MAMA, ACCUM, 52X0.2</td> <td>G140M 1222 A</td> <td></td> <td></td> <td></td> <td>2900 Secs (2900 Secs) [==>]</td> <td>[4]</td> </tr> </tbody> </table>										#	Label (ETC Run)	Target	Config,Mode,Aperture	Spectral Els.	Opt. Params.	Special Reqs.	Groups	Exp. Time (Total)/[Actual Dur.]	Orbit	1	(STIS.ta.100 5473)	(1) -PHI-LEO	STIS/CCD, ACQ, F25ND5	MIRROR				1.5 Secs (1.5 Secs) [==>]	[1]	2	(STIS.sp.10 05483)	(1) -PHI-LEO	STIS/CCD, ACQ/PEAK, 0.2X0.09	G430M 5471 A				0.3 Secs (0.3 Secs) [==>]	[1]	3	(STIS.sp.10 05483)	(1) -PHI-LEO	STIS/CCD, ACQ/PEAK, 0.1X0.03	G430M 5471 A				0.3 Secs (0.3 Secs) [==>]	[1]	4	(STIS.sp.10 05542)	(1) -PHI-LEO	STIS/NUV-MAMA, ACCUM, 0.1X0.03	E230H 2762 A				190 Secs (190 Secs) [==>]	[1]	5	(STIS.sp.10 05543)	(1) -PHI-LEO	STIS/NUV-MAMA, ACCUM, 0.1X0.03	E230H 2513 A				199 Secs (199 Secs) [==>]	[1]	6	(STIS.sp.10 05545)	(1) -PHI-LEO	STIS/NUV-MAMA, ACCUM, 0.1X0.03	E230H 1763 A				199 Secs (199 Secs) [==>]	[1]	7	(STIS.sp.90 5752)	(1) -PHI-LEO	STIS/FUV-MAMA, ACCUM, 0.2X0.2	E140M 1425 A				2900 Secs (2900 Secs) [==>]	[2]	8	(STIS.sp.90 5752)	(1) -PHI-LEO	STIS/FUV-MAMA, ACCUM, 52X0.2	G140M 1222 A				2950 Secs (2950 Secs) [==>]	[3]	9	(STIS.sp.10 06634)	(1) -PHI-LEO	STIS/FUV-MAMA, ACCUM, 52X0.2	G140M 1222 A				2900 Secs (2900 Secs) [==>]	[4]
	#	Label (ETC Run)	Target	Config,Mode,Aperture	Spectral Els.	Opt. Params.	Special Reqs.	Groups	Exp. Time (Total)/[Actual Dur.]	Orbit																																																																																																				
	1	(STIS.ta.100 5473)	(1) -PHI-LEO	STIS/CCD, ACQ, F25ND5	MIRROR				1.5 Secs (1.5 Secs) [==>]	[1]																																																																																																				
	2	(STIS.sp.10 05483)	(1) -PHI-LEO	STIS/CCD, ACQ/PEAK, 0.2X0.09	G430M 5471 A				0.3 Secs (0.3 Secs) [==>]	[1]																																																																																																				
	3	(STIS.sp.10 05483)	(1) -PHI-LEO	STIS/CCD, ACQ/PEAK, 0.1X0.03	G430M 5471 A				0.3 Secs (0.3 Secs) [==>]	[1]																																																																																																				
	4	(STIS.sp.10 05542)	(1) -PHI-LEO	STIS/NUV-MAMA, ACCUM, 0.1X0.03	E230H 2762 A				190 Secs (190 Secs) [==>]	[1]																																																																																																				
	5	(STIS.sp.10 05543)	(1) -PHI-LEO	STIS/NUV-MAMA, ACCUM, 0.1X0.03	E230H 2513 A				199 Secs (199 Secs) [==>]	[1]																																																																																																				
	6	(STIS.sp.10 05545)	(1) -PHI-LEO	STIS/NUV-MAMA, ACCUM, 0.1X0.03	E230H 1763 A				199 Secs (199 Secs) [==>]	[1]																																																																																																				
	7	(STIS.sp.90 5752)	(1) -PHI-LEO	STIS/FUV-MAMA, ACCUM, 0.2X0.2	E140M 1425 A				2900 Secs (2900 Secs) [==>]	[2]																																																																																																				
	8	(STIS.sp.90 5752)	(1) -PHI-LEO	STIS/FUV-MAMA, ACCUM, 52X0.2	G140M 1222 A				2950 Secs (2950 Secs) [==>]	[3]																																																																																																				
9	(STIS.sp.10 06634)	(1) -PHI-LEO	STIS/FUV-MAMA, ACCUM, 52X0.2	G140M 1222 A				2900 Secs (2900 Secs) [==>]	[4]																																																																																																					

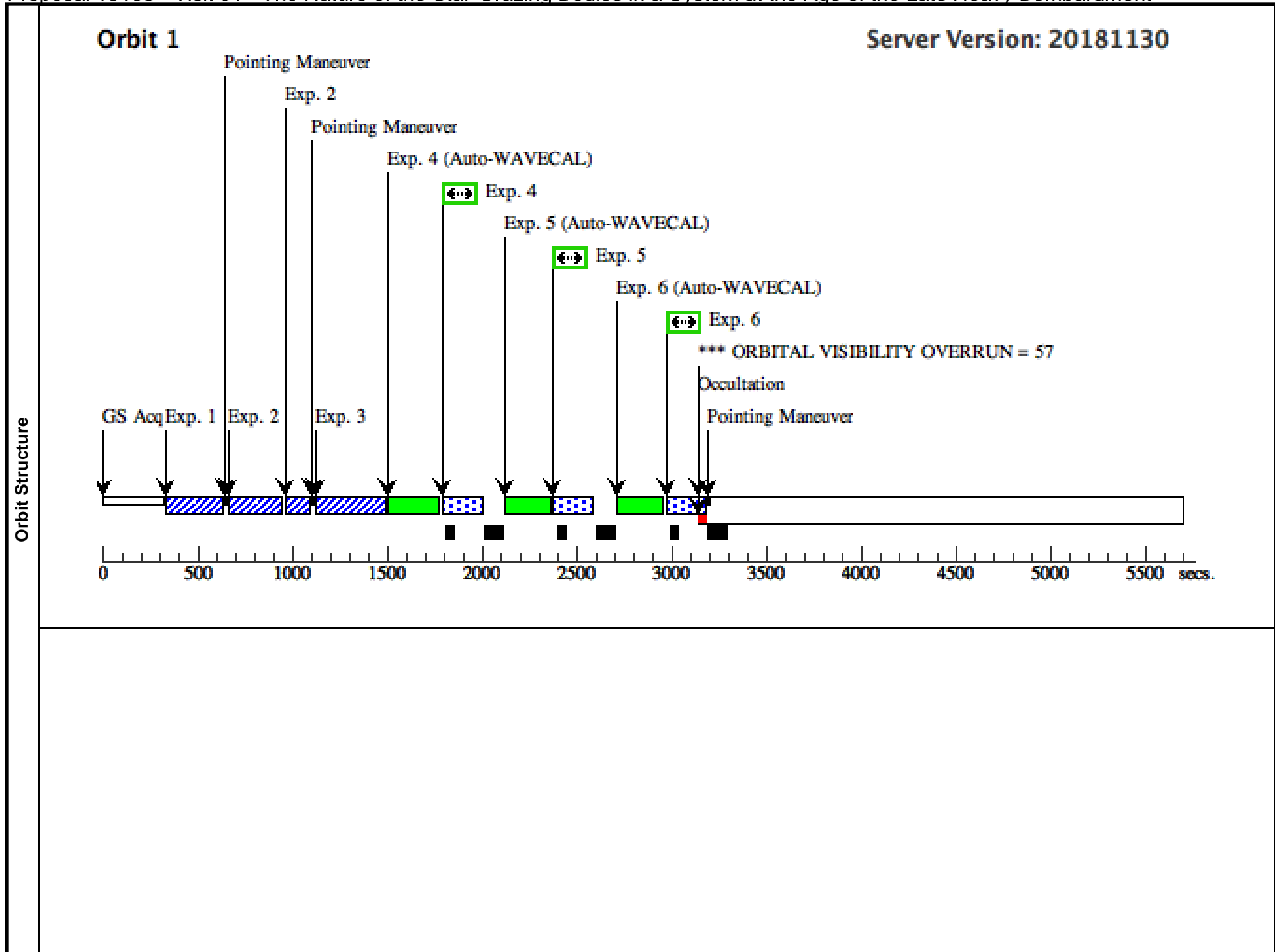

Orbit 2

Server Version: 20181130

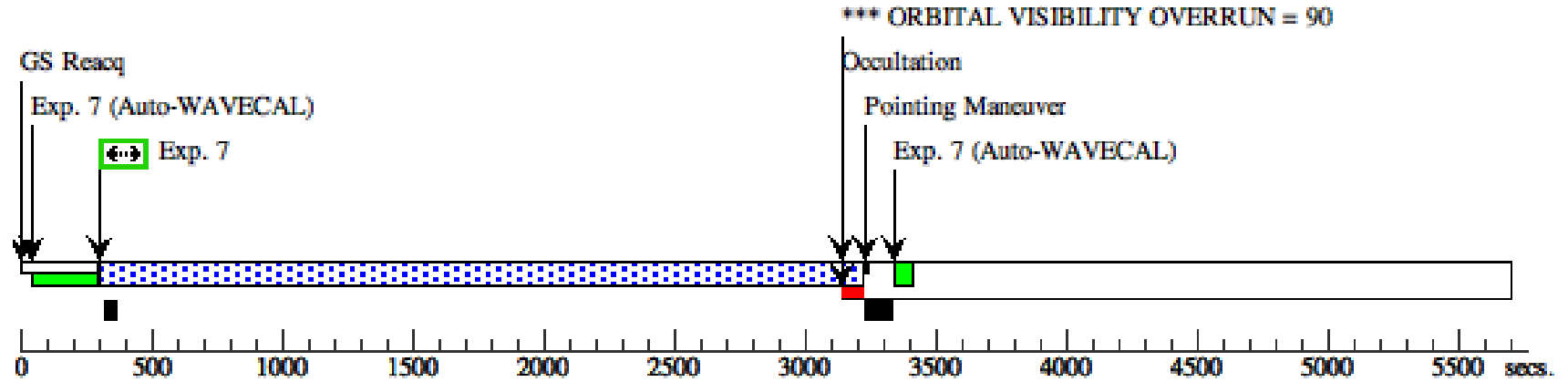

Orbit 3

Server Version: 20181130

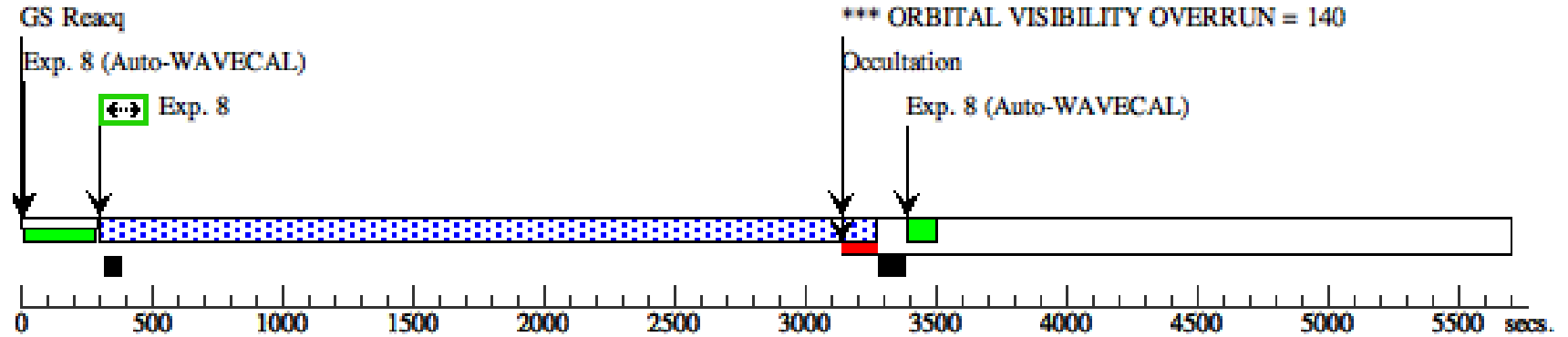

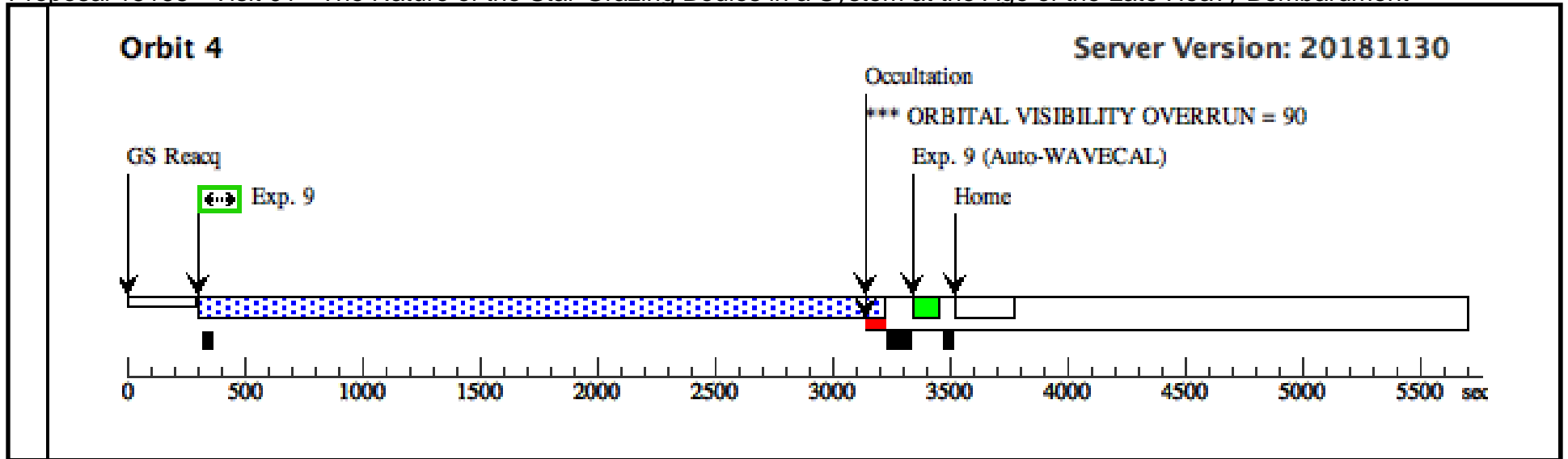

Proposal 15168 - Visit 02 - The Nature of the Star-Grazing Bodies in a System at the Age of the Late Heavy Bombardment

Tue Dec 18 18:01:24 GMT 2018

Visit	Proposal 15168, Visit 02, completed				
	Diagnostic Status: No Diagnostics				
	Scientific Instruments: STIS/CCD, STIS/FUV-MAMA				
	Special Requirements: (none)				

Fixed Targets	#	Name	Target Coordinates	Targ. Coord. Corrections	Fluxes	Miscellaneous
	(2)	-ALF-CEP	RA: 21 18 34.7723 (319.6448846d) Dec: +62 35 8.07 (62.58558d) Equinox: J2000	Proper Motion RA: 150.55 mas/yr Proper Motion Dec: 49.09 mas/yr Parallax: 0.0665" Epoch of Position: 2000 Radial Velocity: -15.80 km/sec	V=2.46+/-0.009 F(2650.1)=2.1E-10, F(1298)=3.7E-13 erg/cm/cm/s/A	Reference Frame: ICRS
	<i>Comments: This object was generated by the targetselector and retrieved from the SIMBAD database.</i>					
	Category=STAR Description=[A4-A9 V-IV, CORONA] Extended=NO					

Exposures	#	Label (ETC Run)	Target	Config,Mode,Aperture	Spectral Els.	Opt. Params.	Special Reqs.	Groups	Exp. Time (Total)/[Actual Dur.]	Orbit
	1	(STIS.TA.1 005849)	(2) -ALF-CEP	STIS/CCD, ACQ, F25ND5	MIRROR				0.2 Secs (0.2 Secs) [==>]	[1]
	2	(STIS.sp.10 05860)	(2) -ALF-CEP	STIS/FUV-MAMA, ACCUM, 52X0.2	G140M 1540 A				900 Secs (900 Secs) [==>]	[1]
	3	(STIS.sp.10 05861)	(2) -ALF-CEP	STIS/FUV-MAMA, ACCUM, 52X0.2	G140M 1321 A				900 Secs (900 Secs) [==>]	[1]

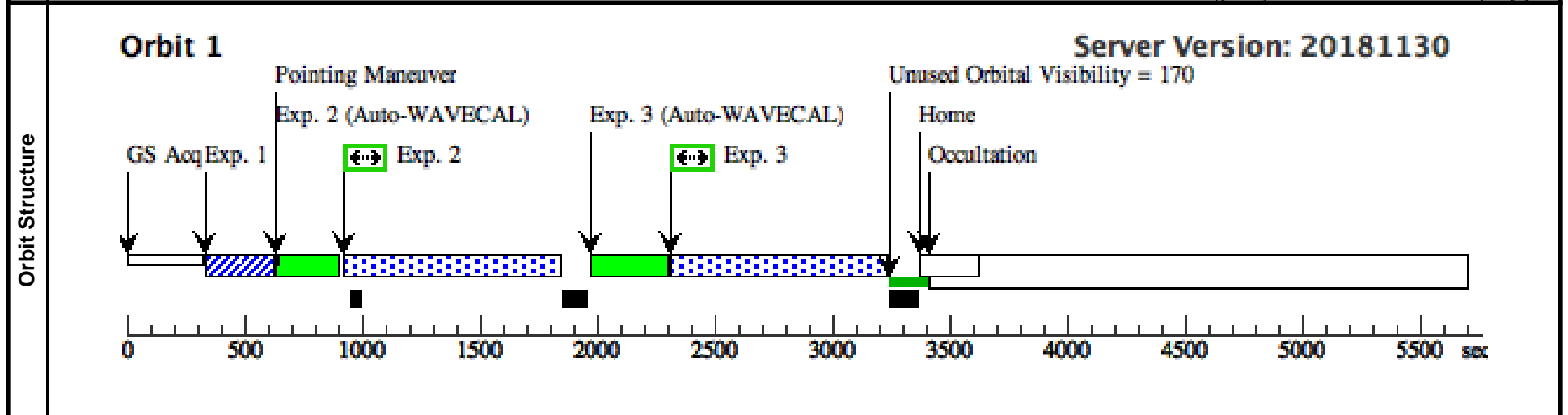

Proposal 15168 - Visit 03 - The Nature of the Star-Grazing Bodies in a System at the Age of the Late Heavy Bombardment

Tue Dec 18 18:01:24 GMT 2018

Visit	Proposal 15168, Visit 03, failed Diagnostic Status: Warning Scientific Instruments: COS/FUV Special Requirements: AFTER 01 BY 0 Orbits TO 4.1 Orbits									
	(Visit 03) Warning (Form): For the best data quality, it is strongly recommended that the maximum number of allowed FP-POS positions is used when observing at a given COS CENWAVE setting. See full description for details. (Visit 03) Warning (Orbit Planner): ORBITAL VISIBILITY OVERRUN (Visit 03) Warning (Orbit Planner): ORBITAL VISIBILITY OVERRUN									
Diagnosics										
Fixed Targets	#	Name	Target Coordinates	Targ. Coord. Corrections	Fluxes	Miscellaneous				
	(1)	-PHI-LEO Alt Name1: HD-98058 Alt Name2: HIP-55084	RA: 11 16 39.6996 (169.1654150d) Dec: -03 39 5.78 (-3.65161d) Equinox: J2000	Proper Motion RA: -110.37 mas/yr Proper Motion Dec: -37.16 mas/yr Parallax: 0.01771" Epoch of Position: 2000 Radial Velocity: -3.0 km/sec	V=4.45+/-0.009 F(2655)=3E-11 erg/cm/cm/s/A (IUE LWP 27899)	Reference Frame: ICRS				
<i>Comments: This object was generated by the targetselector and retrieved from the SIMBAD database.</i> IUE data exist, for both the FUV and NUV, but large aperture data are available only in the NUV. Category=STAR Description=[A4-A9 V-IV, CIRCUMSTELLAR MATTER, CORONA, DISK, EXTRA-SOLAR PLANETARY SYSTEM] Extended=NO										
Exposures	#	Label (ETC Run)	Target	Config,Mode,Aperture	Spectral Els.	Opt. Params.	Special Reqs.	Groups	Exp. Time (Total)/[Actual Dur.]	Orbit
	1	(COS.sa.100 7540)	(1) -PHI-LEO	COS/FUV, ACQ/SEARCH, PSA	G130M 1291 A	SCAN-SIZE=2			4 Secs (4 Secs) [==>]	[1]
	2	(COS.sa.100 7540)	(1) -PHI-LEO	COS/FUV, ACQ/PEAKXD, PSA	G130M 1291 A	NUM-POS=5			4 Secs (4 Secs) [==>]	[1]
	3	(COS.sa.100 7540)	(1) -PHI-LEO	COS/FUV, ACQ/PEAKD, PSA	G130M 1291 A	NUM-POS=5; STEP-SIZE=0.9			4 Secs (4 Secs) [==>]	[1]
	4	(COS.sp.100 7962)	(1) -PHI-LEO	COS/FUV, TIME-TAG, PSA	G130M 1291 A	BUFFER-TIME=70 0; FP-POS=3			2100 Secs (2218 Secs) [==>2218.0 Secs]	[1]
	5	(COS.sp.100 7962)	(1) -PHI-LEO	COS/FUV, TIME-TAG, PSA	G130M 1291 A	BUFFER-TIME=70 0; FP-POS=4			2900 Secs (2916 Secs) [==>2916.0 Secs]	[2]

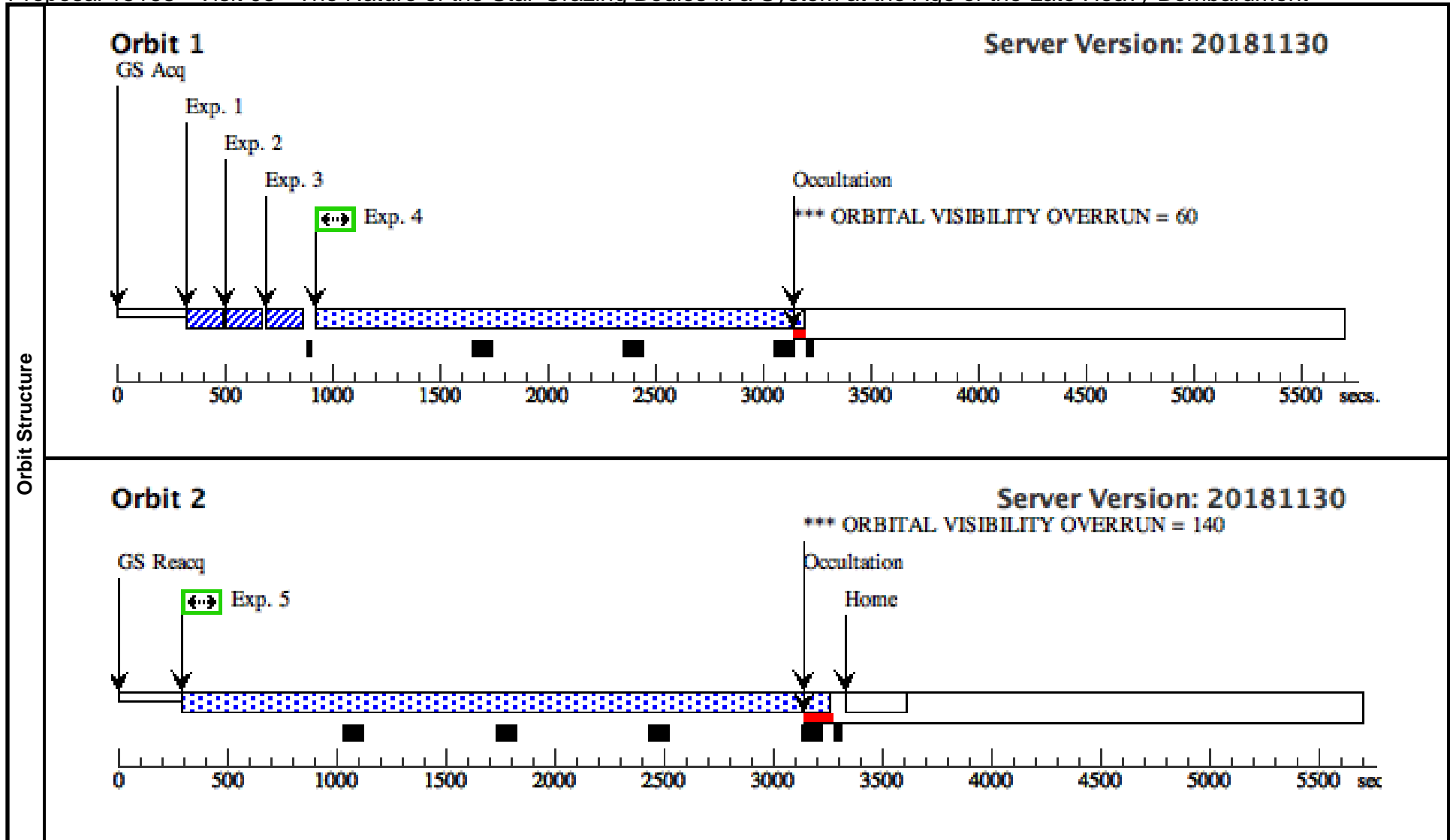

Proposal 15168 - Visit 04 - The Nature of the Star-Grazing Bodies in a System at the Age of the Late Heavy Bombardment

Tue Dec 18 18:01:24 GMT 2018

Visit	Proposal 15168, Visit 04, failed Diagnostic Status: Warning Scientific Instruments: STIS/NUV-MAMA, STIS/CCD, STIS/FUV-MAMA Special Requirements: AFTER 01 BY 14 D TO 20 D; BETWEEN 10-JAN-2018 AND 10-MAY-2018																																																																																																												
	(Visit 04) Warning (Orbit Planner): ORBITAL VISIBILITY OVERRUN (Visit 04) Warning (Orbit Planner): ORBITAL VISIBILITY OVERRUN (Visit 04) Warning (Orbit Planner): ORBITAL VISIBILITY OVERRUN (Visit 04) Warning (Orbit Planner): ORBITAL VISIBILITY OVERRUN																																																																																																												
Fixed Targets	<table border="1"> <thead> <tr> <th>#</th> <th>Name</th> <th>Target Coordinates</th> <th>Targ. Coord. Corrections</th> <th>Fluxes</th> <th>Miscellaneous</th> </tr> </thead> <tbody> <tr> <td>(1)</td> <td>-PHI-LEO Alt Name1: HD-98058 Alt Name2: HIP-55084</td> <td>RA: 11 16 39.6996 (169.1654150d) Dec: -03 39 5.78 (-3.65161d) Equinox: J2000</td> <td>Proper Motion RA: -110.37 mas/yr Proper Motion Dec: -37.16 mas/yr Parallax: 0.01771" Epoch of Position: 2000 Radial Velocity: -3.0 km/sec</td> <td>V=4.45+/-0.009 F(2655)=3E-11 erg/cm/s/A (IUE LWP 27899)</td> <td>Reference Frame: ICRS</td> </tr> </tbody> </table> <p><i>Comments: This object was generated by the targetselector and retrieved from the SIMBAD database.</i></p> <p><i>IUE data exist, for both the FUV and NUV, but large aperture data are available only in the NUV.</i></p> <p><i>Category=STAR</i></p> <p><i>Description=[A4-A9 V-IV, CIRCUMSTELLAR MATTER, CORONA, DISK, EXTRA-SOLAR PLANETARY SYSTEM]</i></p> <p><i>Extended=NO</i></p>										#	Name	Target Coordinates	Targ. Coord. Corrections	Fluxes	Miscellaneous	(1)	-PHI-LEO Alt Name1: HD-98058 Alt Name2: HIP-55084	RA: 11 16 39.6996 (169.1654150d) Dec: -03 39 5.78 (-3.65161d) Equinox: J2000	Proper Motion RA: -110.37 mas/yr Proper Motion Dec: -37.16 mas/yr Parallax: 0.01771" Epoch of Position: 2000 Radial Velocity: -3.0 km/sec	V=4.45+/-0.009 F(2655)=3E-11 erg/cm/s/A (IUE LWP 27899)	Reference Frame: ICRS																																																																																							
	#	Name	Target Coordinates	Targ. Coord. Corrections	Fluxes	Miscellaneous																																																																																																							
(1)	-PHI-LEO Alt Name1: HD-98058 Alt Name2: HIP-55084	RA: 11 16 39.6996 (169.1654150d) Dec: -03 39 5.78 (-3.65161d) Equinox: J2000	Proper Motion RA: -110.37 mas/yr Proper Motion Dec: -37.16 mas/yr Parallax: 0.01771" Epoch of Position: 2000 Radial Velocity: -3.0 km/sec	V=4.45+/-0.009 F(2655)=3E-11 erg/cm/s/A (IUE LWP 27899)	Reference Frame: ICRS																																																																																																								
<table border="1"> <thead> <tr> <th>#</th> <th>Label (ETC Run)</th> <th>Target</th> <th>Config,Mode,Aperture</th> <th>Spectral Els.</th> <th>Opt. Params.</th> <th>Special Reqs.</th> <th>Groups</th> <th>Exp. Time (Total)/[Actual Dur.]</th> <th>Orbit</th> </tr> </thead> <tbody> <tr> <td>1</td> <td>(STIS.ta.100 5473)</td> <td>(1) -PHI-LEO</td> <td>STIS/CCD, ACQ, F25ND5</td> <td>MIRROR</td> <td></td> <td></td> <td></td> <td>1.5 Secs (1.5 Secs) [=>]</td> <td>[1]</td> </tr> <tr> <td>2</td> <td>(STIS.sp.10 05483)</td> <td>(1) -PHI-LEO</td> <td>STIS/CCD, ACQ/PEAK, 0.2X0.09</td> <td>G430M 5471 A</td> <td></td> <td></td> <td></td> <td>0.3 Secs (0.3 Secs) [=>]</td> <td>[1]</td> </tr> <tr> <td>3</td> <td>(STIS.sp.10 05483)</td> <td>(1) -PHI-LEO</td> <td>STIS/CCD, ACQ/PEAK, 0.1X0.03</td> <td>G430M 5471 A</td> <td></td> <td></td> <td></td> <td>0.3 Secs (0.3 Secs) [=>]</td> <td>[1]</td> </tr> <tr> <td>4</td> <td>(STIS.sp.10 05542)</td> <td>(1) -PHI-LEO</td> <td>STIS/NUV-MAMA, ACCUM, 0.1X0.03</td> <td>E230H 2762 A</td> <td></td> <td></td> <td></td> <td>190 Secs (190 Secs) [=>]</td> <td>[1]</td> </tr> <tr> <td>5</td> <td>(STIS.sp.10 05543)</td> <td>(1) -PHI-LEO</td> <td>STIS/NUV-MAMA, ACCUM, 0.1X0.03</td> <td>E230H 2513 A</td> <td></td> <td></td> <td></td> <td>199 Secs (199 Secs) [=>]</td> <td>[1]</td> </tr> <tr> <td>6</td> <td>(STIS.sp.10 05545)</td> <td>(1) -PHI-LEO</td> <td>STIS/NUV-MAMA, ACCUM, 0.1X0.03</td> <td>E230H 1763 A</td> <td></td> <td></td> <td></td> <td>199 Secs (199 Secs) [=>]</td> <td>[1]</td> </tr> <tr> <td>7</td> <td>(STIS.sp.90 5752)</td> <td>(1) -PHI-LEO</td> <td>STIS/FUV-MAMA, ACCUM, 0.2X0.2</td> <td>E140M 1425 A</td> <td></td> <td></td> <td></td> <td>2900 Secs (2900 Secs) [=>]</td> <td>[2]</td> </tr> <tr> <td>8</td> <td>(STIS.sp.90 5752)</td> <td>(1) -PHI-LEO</td> <td>STIS/FUV-MAMA, ACCUM, 52X0.2</td> <td>G140M 1222 A</td> <td></td> <td></td> <td></td> <td>2950 Secs (2950 Secs) [=>]</td> <td>[3]</td> </tr> <tr> <td>9</td> <td>(STIS.sp.10 06634)</td> <td>(1) -PHI-LEO</td> <td>STIS/FUV-MAMA, ACCUM, 52X0.2</td> <td>G140M 1222 A</td> <td></td> <td></td> <td></td> <td>2900 Secs (2900 Secs) [=>]</td> <td>[4]</td> </tr> </tbody> </table>										#	Label (ETC Run)	Target	Config,Mode,Aperture	Spectral Els.	Opt. Params.	Special Reqs.	Groups	Exp. Time (Total)/[Actual Dur.]	Orbit	1	(STIS.ta.100 5473)	(1) -PHI-LEO	STIS/CCD, ACQ, F25ND5	MIRROR				1.5 Secs (1.5 Secs) [=>]	[1]	2	(STIS.sp.10 05483)	(1) -PHI-LEO	STIS/CCD, ACQ/PEAK, 0.2X0.09	G430M 5471 A				0.3 Secs (0.3 Secs) [=>]	[1]	3	(STIS.sp.10 05483)	(1) -PHI-LEO	STIS/CCD, ACQ/PEAK, 0.1X0.03	G430M 5471 A				0.3 Secs (0.3 Secs) [=>]	[1]	4	(STIS.sp.10 05542)	(1) -PHI-LEO	STIS/NUV-MAMA, ACCUM, 0.1X0.03	E230H 2762 A				190 Secs (190 Secs) [=>]	[1]	5	(STIS.sp.10 05543)	(1) -PHI-LEO	STIS/NUV-MAMA, ACCUM, 0.1X0.03	E230H 2513 A				199 Secs (199 Secs) [=>]	[1]	6	(STIS.sp.10 05545)	(1) -PHI-LEO	STIS/NUV-MAMA, ACCUM, 0.1X0.03	E230H 1763 A				199 Secs (199 Secs) [=>]	[1]	7	(STIS.sp.90 5752)	(1) -PHI-LEO	STIS/FUV-MAMA, ACCUM, 0.2X0.2	E140M 1425 A				2900 Secs (2900 Secs) [=>]	[2]	8	(STIS.sp.90 5752)	(1) -PHI-LEO	STIS/FUV-MAMA, ACCUM, 52X0.2	G140M 1222 A				2950 Secs (2950 Secs) [=>]	[3]	9	(STIS.sp.10 06634)	(1) -PHI-LEO	STIS/FUV-MAMA, ACCUM, 52X0.2	G140M 1222 A				2900 Secs (2900 Secs) [=>]	[4]
#	Label (ETC Run)	Target	Config,Mode,Aperture	Spectral Els.	Opt. Params.	Special Reqs.	Groups	Exp. Time (Total)/[Actual Dur.]	Orbit																																																																																																				
1	(STIS.ta.100 5473)	(1) -PHI-LEO	STIS/CCD, ACQ, F25ND5	MIRROR				1.5 Secs (1.5 Secs) [=>]	[1]																																																																																																				
2	(STIS.sp.10 05483)	(1) -PHI-LEO	STIS/CCD, ACQ/PEAK, 0.2X0.09	G430M 5471 A				0.3 Secs (0.3 Secs) [=>]	[1]																																																																																																				
3	(STIS.sp.10 05483)	(1) -PHI-LEO	STIS/CCD, ACQ/PEAK, 0.1X0.03	G430M 5471 A				0.3 Secs (0.3 Secs) [=>]	[1]																																																																																																				
4	(STIS.sp.10 05542)	(1) -PHI-LEO	STIS/NUV-MAMA, ACCUM, 0.1X0.03	E230H 2762 A				190 Secs (190 Secs) [=>]	[1]																																																																																																				
5	(STIS.sp.10 05543)	(1) -PHI-LEO	STIS/NUV-MAMA, ACCUM, 0.1X0.03	E230H 2513 A				199 Secs (199 Secs) [=>]	[1]																																																																																																				
6	(STIS.sp.10 05545)	(1) -PHI-LEO	STIS/NUV-MAMA, ACCUM, 0.1X0.03	E230H 1763 A				199 Secs (199 Secs) [=>]	[1]																																																																																																				
7	(STIS.sp.90 5752)	(1) -PHI-LEO	STIS/FUV-MAMA, ACCUM, 0.2X0.2	E140M 1425 A				2900 Secs (2900 Secs) [=>]	[2]																																																																																																				
8	(STIS.sp.90 5752)	(1) -PHI-LEO	STIS/FUV-MAMA, ACCUM, 52X0.2	G140M 1222 A				2950 Secs (2950 Secs) [=>]	[3]																																																																																																				
9	(STIS.sp.10 06634)	(1) -PHI-LEO	STIS/FUV-MAMA, ACCUM, 52X0.2	G140M 1222 A				2900 Secs (2900 Secs) [=>]	[4]																																																																																																				

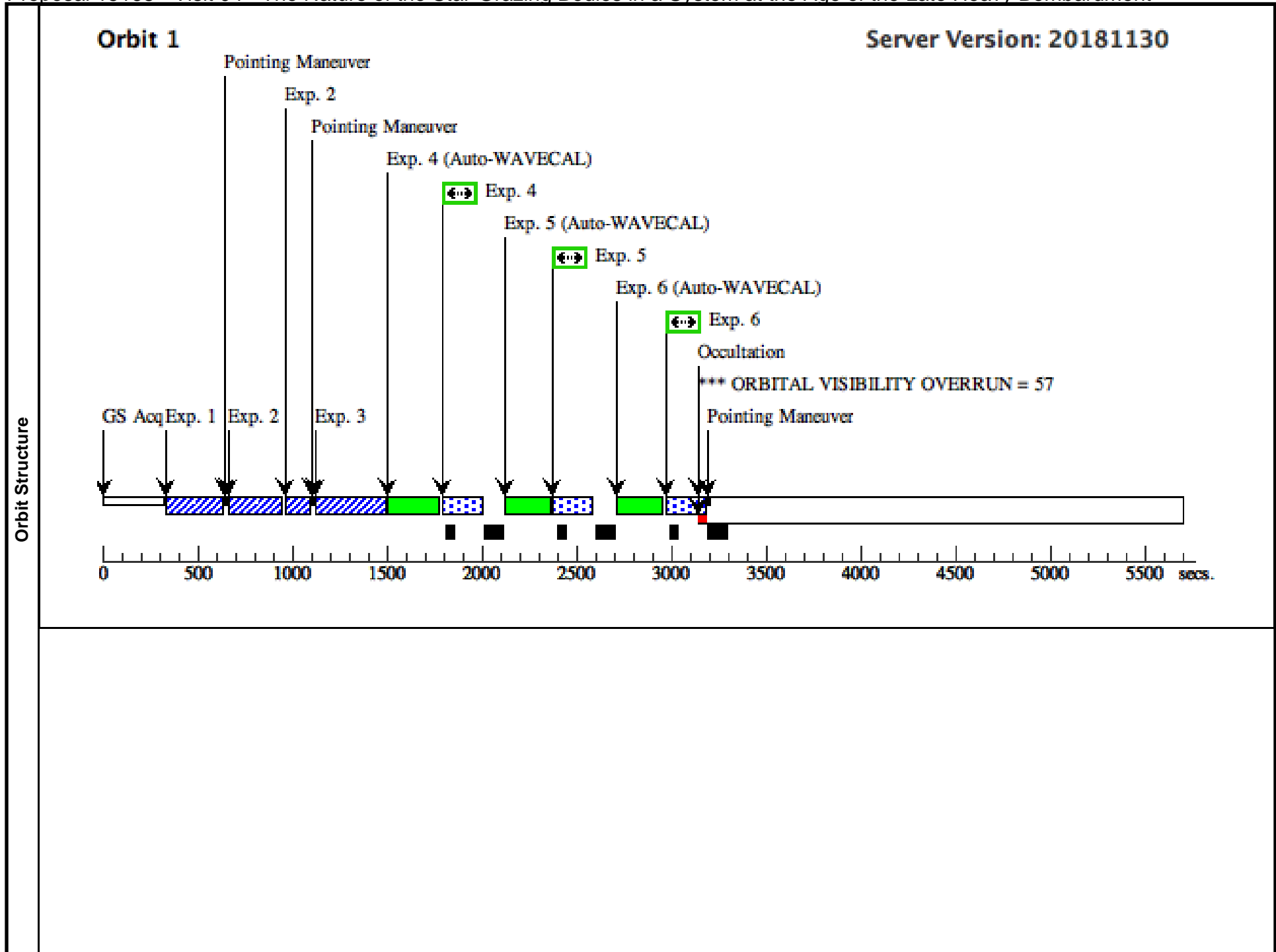

Orbit 2

Server Version: 20181130

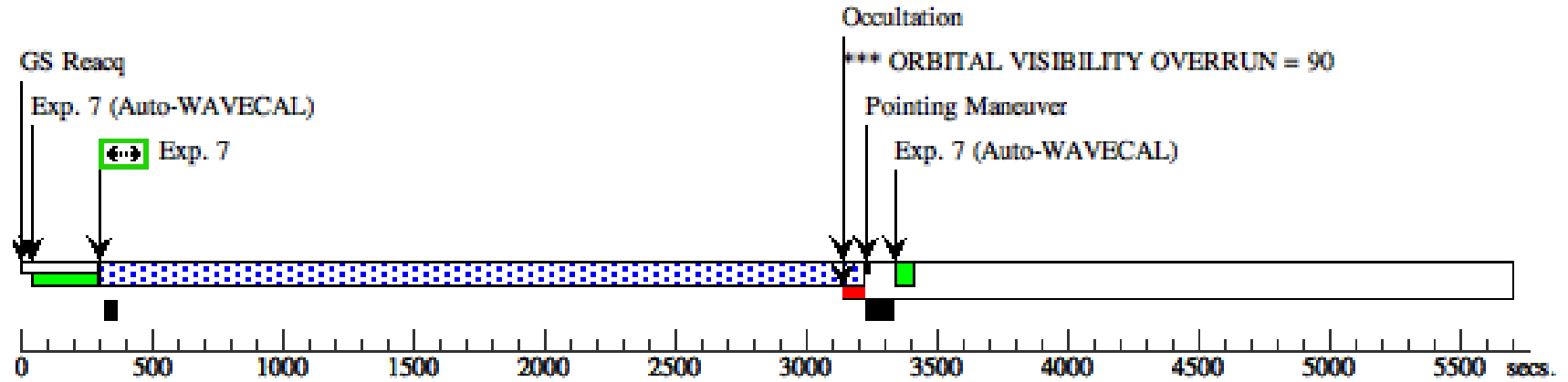

Orbit 3

Server Version: 20181130

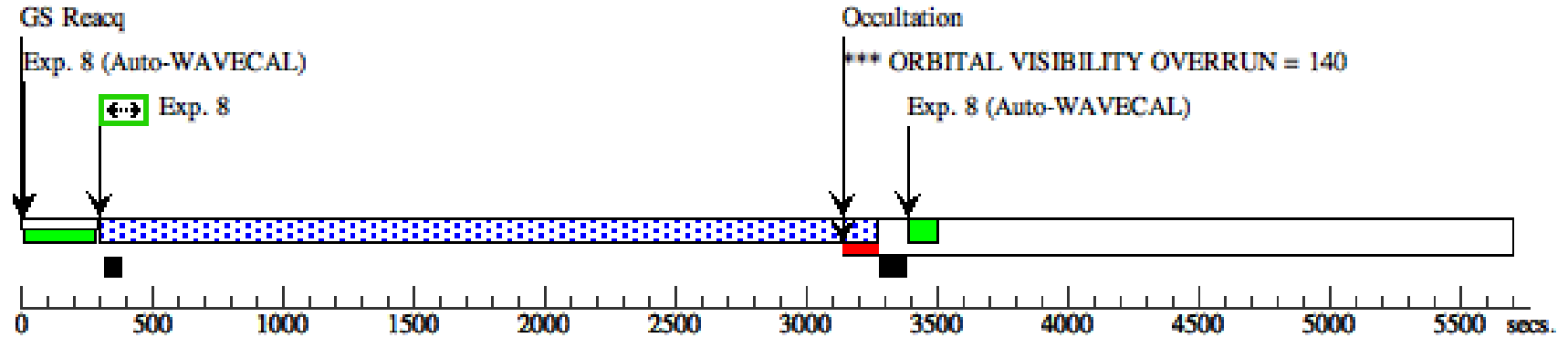

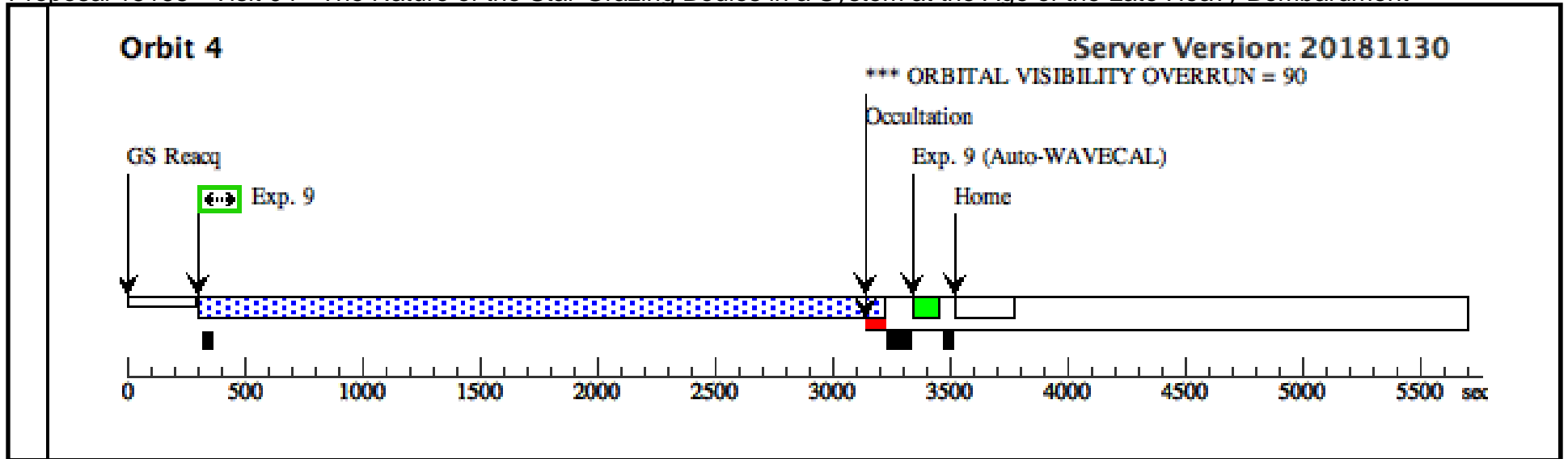

Proposal 15168 - Visit 05 - The Nature of the Star-Grazing Bodies in a System at the Age of the Late Heavy Bombardment

Tue Dec 18 18:01:24 GMT 2018

Visit	Proposal 15168, Visit 05, failed Diagnostic Status: Warning Scientific Instruments: COS/FUV Special Requirements: AFTER 04 BY 0 Orbits TO 4.1 Orbits									
	(Visit 05) Warning (Form): For the best data quality, it is strongly recommended that the maximum number of allowed FP-POS positions is used when observing at a given COS CENWAVE setting. See full description for details. (Visit 05) Warning (Orbit Planner): ORBITAL VISIBILITY OVERRUN (Visit 05) Warning (Orbit Planner): ORBITAL VISIBILITY OVERRUN									
Diagnosics										
Fixed Targets	#	Name	Target Coordinates	Targ. Coord. Corrections		Fluxes	Miscellaneous			
	(1)	-PHI-LEO Alt Name1: HD-98058 Alt Name2: HIP-55084	RA: 11 16 39.6996 (169.1654150d) Dec: -03 39 5.78 (-3.65161d) Equinox: J2000	Proper Motion RA: -110.37 mas/yr Proper Motion Dec: -37.16 mas/yr Parallax: 0.01771" Epoch of Position: 2000 Radial Velocity: -3.0 km/sec	V=4.45+/-0.009		Reference Frame: ICRS F(2655)=3E-11 erg/cm/cm/s/A (IUE LWP 27899)			
<i>Comments: This object was generated by the targetselector and retrieved from the SIMBAD database.</i> IUE data exist, for both the FUV and NUV, but large aperture data are available only in the NUV. Category=STAR Description=[A4-A9 V-IV, CIRCUMSTELLAR MATTER, CORONA, DISK, EXTRA-SOLAR PLANETARY SYSTEM] Extended=NO										
Exposures	#	Label (ETC Run)	Target	Config,Mode,Aperture	Spectral Els.	Opt. Params.	Special Reqs.	Groups	Exp. Time (Total)/[Actual Dur.]	Orbit
	1	(COS.sa.100 7540)	(1) -PHI-LEO	COS/FUV, ACQ/SEARCH, PSA	G130M 1291 A	SCAN-SIZE=2			4 Secs (4 Secs) [==>]	[1]
	2	(COS.sa.100 7540)	(1) -PHI-LEO	COS/FUV, ACQ/PEAKXD, PSA	G130M 1291 A	NUM-POS=5			4 Secs (4 Secs) [==>]	[1]
	3	(COS.sa.100 7540)	(1) -PHI-LEO	COS/FUV, ACQ/PEAKD, PSA	G130M 1291 A	NUM-POS=5; STEP-SIZE=0.9			4 Secs (4 Secs) [==>]	[1]
	4	(COS.sp.100 7962)	(1) -PHI-LEO	COS/FUV, TIME-TAG, PSA	G130M 1291 A	BUFFER-TIME=70 0; FP-POS=3			1599 Secs (2218 Secs) [==>2218.0 Secs]	[1]
	5	(COS.sp.100 7962)	(1) -PHI-LEO	COS/FUV, TIME-TAG, PSA	G130M 1291 A	BUFFER-TIME=70 0; FP-POS=4			2900 Secs (2916 Secs) [==>2916.0 Secs]	[2]

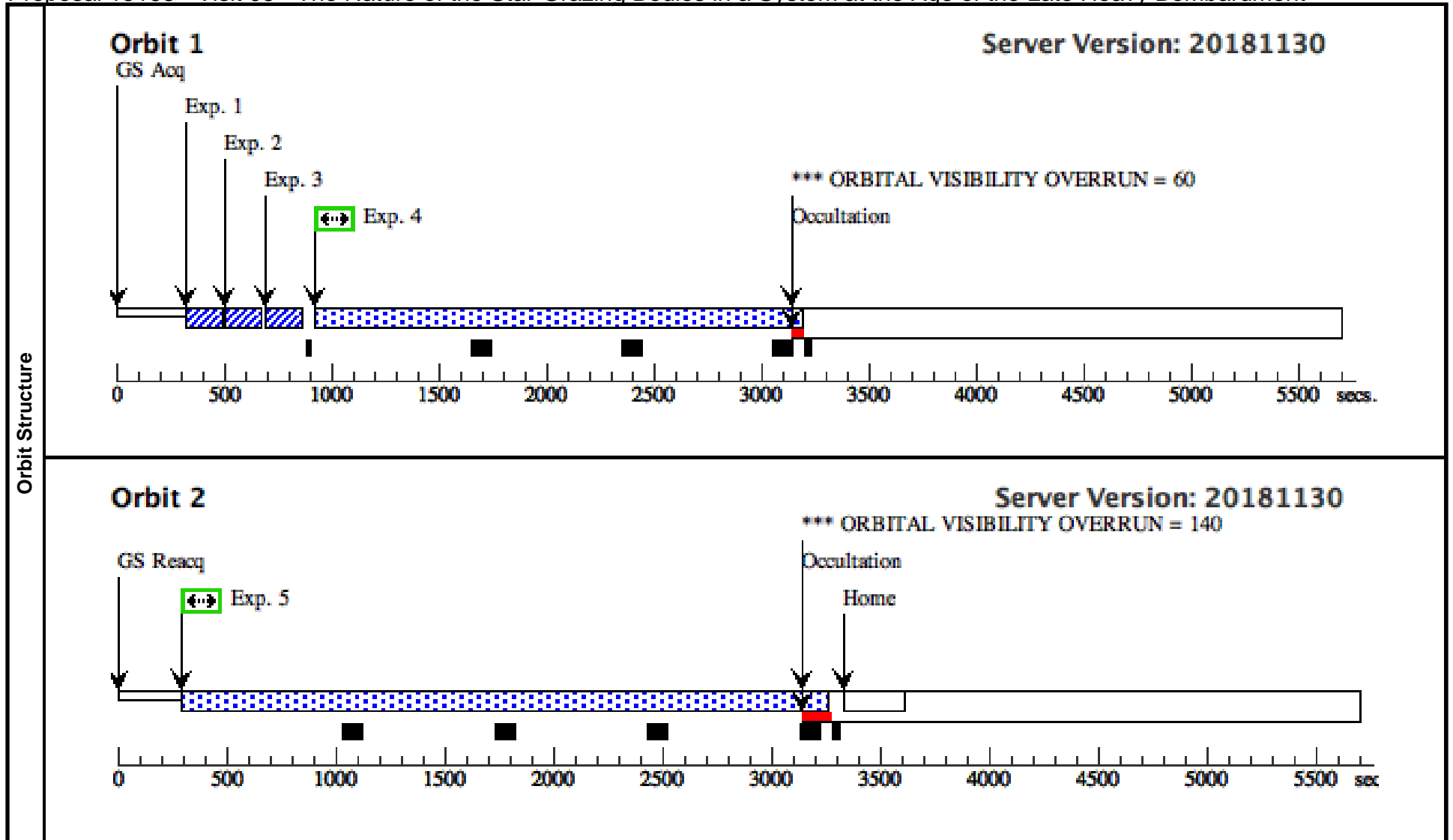

Proposal 15168 - Visit 51 - The Nature of the Star-Grazing Bodies in a System at the Age of the Late Heavy Bombardment

Tue Dec 18 18:01:24 GMT 2018

Visit	Proposal 15168, Visit 51, failed Diagnostic Status: Warning Scientific Instruments: STIS/NUV-MAMA, STIS/CCD, STIS/FUV-MAMA Special Requirements: BETWEEN 10-JAN-2018 AND 21-MAY-2018:00:00:00																																																																																																												
	(Visit 51) Warning (Orbit Planner): ORBITAL VISIBILITY OVERRUN (Visit 51) Warning (Orbit Planner): ORBITAL VISIBILITY OVERRUN (Visit 51) Warning (Orbit Planner): ORBITAL VISIBILITY OVERRUN (Visit 51) Warning (Orbit Planner): ORBITAL VISIBILITY OVERRUN																																																																																																												
Fixed Targets	<table border="1"> <thead> <tr> <th>#</th> <th>Name</th> <th>Target Coordinates</th> <th>Targ. Coord. Corrections</th> <th>Fluxes</th> <th>Miscellaneous</th> </tr> </thead> <tbody> <tr> <td>(1)</td> <td>-PHI-LEO Alt Name1: HD-98058 Alt Name2: HIP-55084</td> <td>RA: 11 16 39.6996 (169.1654150d) Dec: -03 39 5.78 (-3.65161d) Equinox: J2000</td> <td>Proper Motion RA: -110.37 mas/yr Proper Motion Dec: -37.16 mas/yr Parallax: 0.01771" Epoch of Position: 2000 Radial Velocity: -3.0 km/sec</td> <td>V=4.45+/-0.009 F(2655)=3E-11 erg/cm/cm/s/A (IUE LWP 27899)</td> <td>Reference Frame: ICRS</td> </tr> </tbody> </table> <p><i>Comments: This object was generated by the targetselector and retrieved from the SIMBAD database.</i></p> <p><i>IUE data exist, for both the FUV and NUV, but large aperture data are available only in the NUV.</i></p> <p><i>Category=STAR</i> <i>Description=[A4-A9 V-IV, CIRCUMSTELLAR MATTER, CORONA, DISK, EXTRA-SOLAR PLANETARY SYSTEM]</i> <i>Extended=NO</i></p>										#	Name	Target Coordinates	Targ. Coord. Corrections	Fluxes	Miscellaneous	(1)	-PHI-LEO Alt Name1: HD-98058 Alt Name2: HIP-55084	RA: 11 16 39.6996 (169.1654150d) Dec: -03 39 5.78 (-3.65161d) Equinox: J2000	Proper Motion RA: -110.37 mas/yr Proper Motion Dec: -37.16 mas/yr Parallax: 0.01771" Epoch of Position: 2000 Radial Velocity: -3.0 km/sec	V=4.45+/-0.009 F(2655)=3E-11 erg/cm/cm/s/A (IUE LWP 27899)	Reference Frame: ICRS																																																																																							
	#	Name	Target Coordinates	Targ. Coord. Corrections	Fluxes	Miscellaneous																																																																																																							
(1)	-PHI-LEO Alt Name1: HD-98058 Alt Name2: HIP-55084	RA: 11 16 39.6996 (169.1654150d) Dec: -03 39 5.78 (-3.65161d) Equinox: J2000	Proper Motion RA: -110.37 mas/yr Proper Motion Dec: -37.16 mas/yr Parallax: 0.01771" Epoch of Position: 2000 Radial Velocity: -3.0 km/sec	V=4.45+/-0.009 F(2655)=3E-11 erg/cm/cm/s/A (IUE LWP 27899)	Reference Frame: ICRS																																																																																																								
<table border="1"> <thead> <tr> <th>#</th> <th>Label (ETC Run)</th> <th>Target</th> <th>Config,Mode,Aperture</th> <th>Spectral Els.</th> <th>Opt. Params.</th> <th>Special Reqs.</th> <th>Groups</th> <th>Exp. Time (Total)/[Actual Dur.]</th> <th>Orbit</th> </tr> </thead> <tbody> <tr> <td>1</td> <td>(STIS.ta.100 5473)</td> <td>(1) -PHI-LEO</td> <td>STIS/CCD, ACQ, F25ND5</td> <td>MIRROR</td> <td></td> <td></td> <td></td> <td>1.5 Secs (1.5 Secs) [==>]</td> <td>[1]</td> </tr> <tr> <td>2</td> <td>(STIS.sp.10 05483)</td> <td>(1) -PHI-LEO</td> <td>STIS/CCD, ACQ/PEAK, 0.2X0.09</td> <td>G430M 5471 A</td> <td></td> <td></td> <td></td> <td>0.3 Secs (0.3 Secs) [==>]</td> <td>[1]</td> </tr> <tr> <td>3</td> <td>(STIS.sp.10 05483)</td> <td>(1) -PHI-LEO</td> <td>STIS/CCD, ACQ/PEAK, 0.1X0.03</td> <td>G430M 5471 A</td> <td></td> <td></td> <td></td> <td>0.3 Secs (0.3 Secs) [==>]</td> <td>[1]</td> </tr> <tr> <td>4</td> <td>(STIS.sp.10 05542)</td> <td>(1) -PHI-LEO</td> <td>STIS/NUV-MAMA, ACCUM, 0.1X0.03</td> <td>E230H 2762 A</td> <td></td> <td></td> <td></td> <td>190 Secs (190 Secs) [==>]</td> <td>[1]</td> </tr> <tr> <td>5</td> <td>(STIS.sp.10 05543)</td> <td>(1) -PHI-LEO</td> <td>STIS/NUV-MAMA, ACCUM, 0.1X0.03</td> <td>E230H 2513 A</td> <td></td> <td></td> <td></td> <td>199 Secs (199 Secs) [==>]</td> <td>[1]</td> </tr> <tr> <td>6</td> <td>(STIS.sp.10 05545)</td> <td>(1) -PHI-LEO</td> <td>STIS/NUV-MAMA, ACCUM, 0.1X0.03</td> <td>E230H 1763 A</td> <td></td> <td></td> <td></td> <td>199 Secs (199 Secs) [==>]</td> <td>[1]</td> </tr> <tr> <td>7</td> <td>(STIS.sp.90 5752)</td> <td>(1) -PHI-LEO</td> <td>STIS/FUV-MAMA, ACCUM, 0.2X0.2</td> <td>E140M 1425 A</td> <td></td> <td></td> <td></td> <td>2900 Secs (2900 Secs) [==>]</td> <td>[2]</td> </tr> <tr> <td>8</td> <td>(STIS.sp.90 5752)</td> <td>(1) -PHI-LEO</td> <td>STIS/FUV-MAMA, ACCUM, 52X0.2</td> <td>G140M 1222 A</td> <td></td> <td></td> <td></td> <td>2950 Secs (2950 Secs) [==>]</td> <td>[3]</td> </tr> <tr> <td>9</td> <td>(STIS.sp.10 06634)</td> <td>(1) -PHI-LEO</td> <td>STIS/FUV-MAMA, ACCUM, 52X0.2</td> <td>G140M 1222 A</td> <td></td> <td></td> <td></td> <td>2900 Secs (2900 Secs) [==>]</td> <td>[4]</td> </tr> </tbody> </table>										#	Label (ETC Run)	Target	Config,Mode,Aperture	Spectral Els.	Opt. Params.	Special Reqs.	Groups	Exp. Time (Total)/[Actual Dur.]	Orbit	1	(STIS.ta.100 5473)	(1) -PHI-LEO	STIS/CCD, ACQ, F25ND5	MIRROR				1.5 Secs (1.5 Secs) [==>]	[1]	2	(STIS.sp.10 05483)	(1) -PHI-LEO	STIS/CCD, ACQ/PEAK, 0.2X0.09	G430M 5471 A				0.3 Secs (0.3 Secs) [==>]	[1]	3	(STIS.sp.10 05483)	(1) -PHI-LEO	STIS/CCD, ACQ/PEAK, 0.1X0.03	G430M 5471 A				0.3 Secs (0.3 Secs) [==>]	[1]	4	(STIS.sp.10 05542)	(1) -PHI-LEO	STIS/NUV-MAMA, ACCUM, 0.1X0.03	E230H 2762 A				190 Secs (190 Secs) [==>]	[1]	5	(STIS.sp.10 05543)	(1) -PHI-LEO	STIS/NUV-MAMA, ACCUM, 0.1X0.03	E230H 2513 A				199 Secs (199 Secs) [==>]	[1]	6	(STIS.sp.10 05545)	(1) -PHI-LEO	STIS/NUV-MAMA, ACCUM, 0.1X0.03	E230H 1763 A				199 Secs (199 Secs) [==>]	[1]	7	(STIS.sp.90 5752)	(1) -PHI-LEO	STIS/FUV-MAMA, ACCUM, 0.2X0.2	E140M 1425 A				2900 Secs (2900 Secs) [==>]	[2]	8	(STIS.sp.90 5752)	(1) -PHI-LEO	STIS/FUV-MAMA, ACCUM, 52X0.2	G140M 1222 A				2950 Secs (2950 Secs) [==>]	[3]	9	(STIS.sp.10 06634)	(1) -PHI-LEO	STIS/FUV-MAMA, ACCUM, 52X0.2	G140M 1222 A				2900 Secs (2900 Secs) [==>]	[4]
#	Label (ETC Run)	Target	Config,Mode,Aperture	Spectral Els.	Opt. Params.	Special Reqs.	Groups	Exp. Time (Total)/[Actual Dur.]	Orbit																																																																																																				
1	(STIS.ta.100 5473)	(1) -PHI-LEO	STIS/CCD, ACQ, F25ND5	MIRROR				1.5 Secs (1.5 Secs) [==>]	[1]																																																																																																				
2	(STIS.sp.10 05483)	(1) -PHI-LEO	STIS/CCD, ACQ/PEAK, 0.2X0.09	G430M 5471 A				0.3 Secs (0.3 Secs) [==>]	[1]																																																																																																				
3	(STIS.sp.10 05483)	(1) -PHI-LEO	STIS/CCD, ACQ/PEAK, 0.1X0.03	G430M 5471 A				0.3 Secs (0.3 Secs) [==>]	[1]																																																																																																				
4	(STIS.sp.10 05542)	(1) -PHI-LEO	STIS/NUV-MAMA, ACCUM, 0.1X0.03	E230H 2762 A				190 Secs (190 Secs) [==>]	[1]																																																																																																				
5	(STIS.sp.10 05543)	(1) -PHI-LEO	STIS/NUV-MAMA, ACCUM, 0.1X0.03	E230H 2513 A				199 Secs (199 Secs) [==>]	[1]																																																																																																				
6	(STIS.sp.10 05545)	(1) -PHI-LEO	STIS/NUV-MAMA, ACCUM, 0.1X0.03	E230H 1763 A				199 Secs (199 Secs) [==>]	[1]																																																																																																				
7	(STIS.sp.90 5752)	(1) -PHI-LEO	STIS/FUV-MAMA, ACCUM, 0.2X0.2	E140M 1425 A				2900 Secs (2900 Secs) [==>]	[2]																																																																																																				
8	(STIS.sp.90 5752)	(1) -PHI-LEO	STIS/FUV-MAMA, ACCUM, 52X0.2	G140M 1222 A				2950 Secs (2950 Secs) [==>]	[3]																																																																																																				
9	(STIS.sp.10 06634)	(1) -PHI-LEO	STIS/FUV-MAMA, ACCUM, 52X0.2	G140M 1222 A				2900 Secs (2900 Secs) [==>]	[4]																																																																																																				

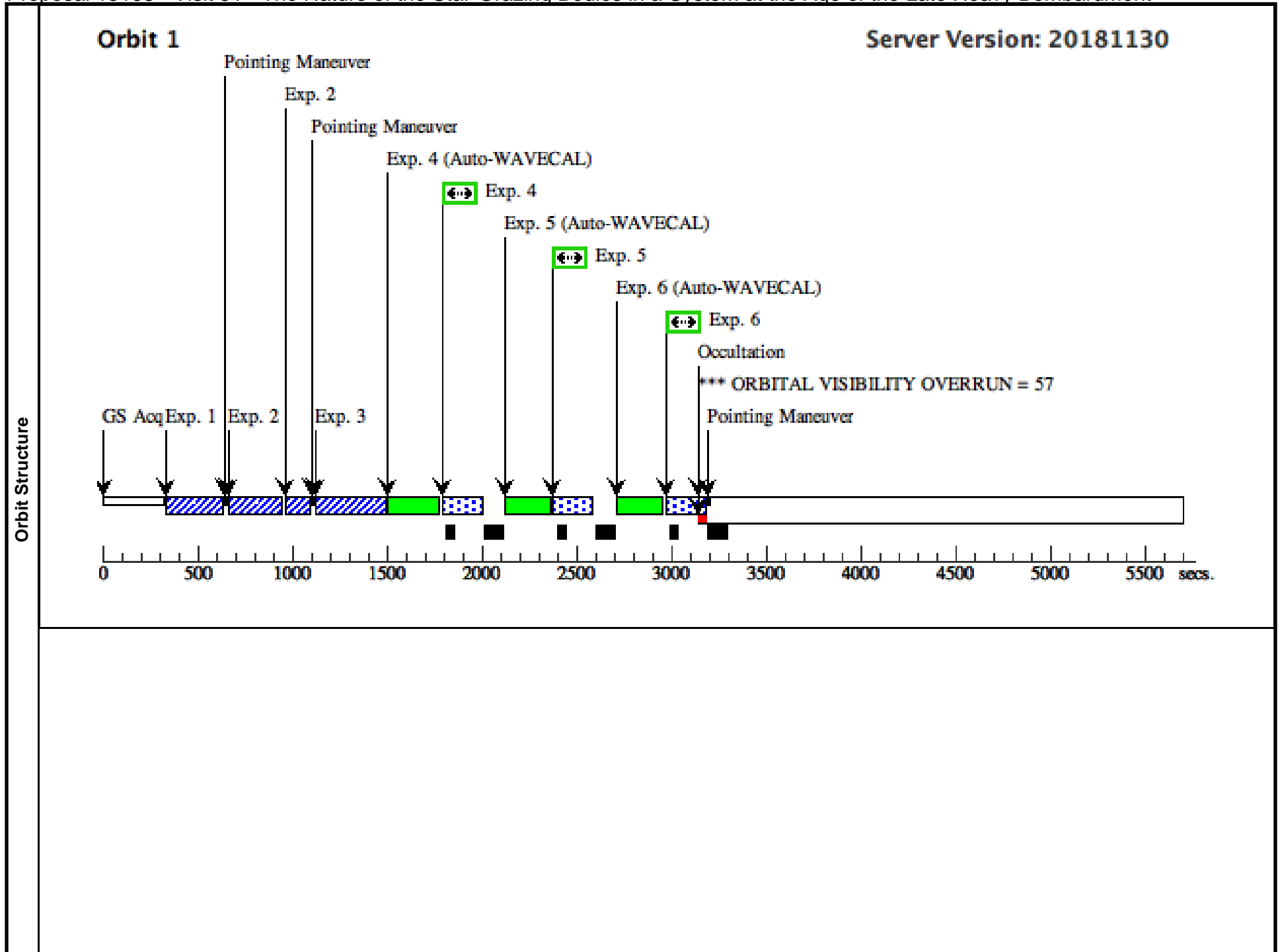

Orbit 2

Server Version: 20181130

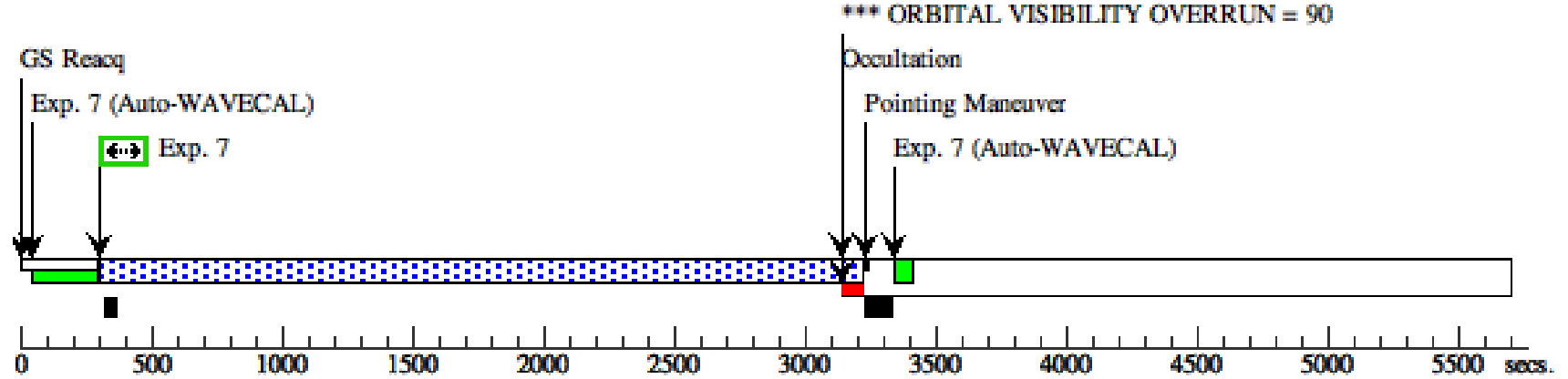

Orbit 3

Server Version: 20181130

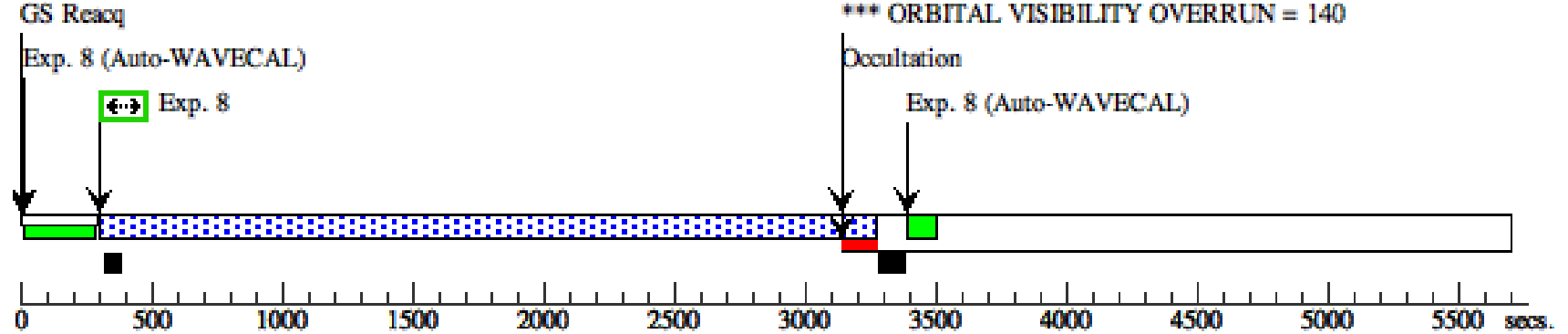

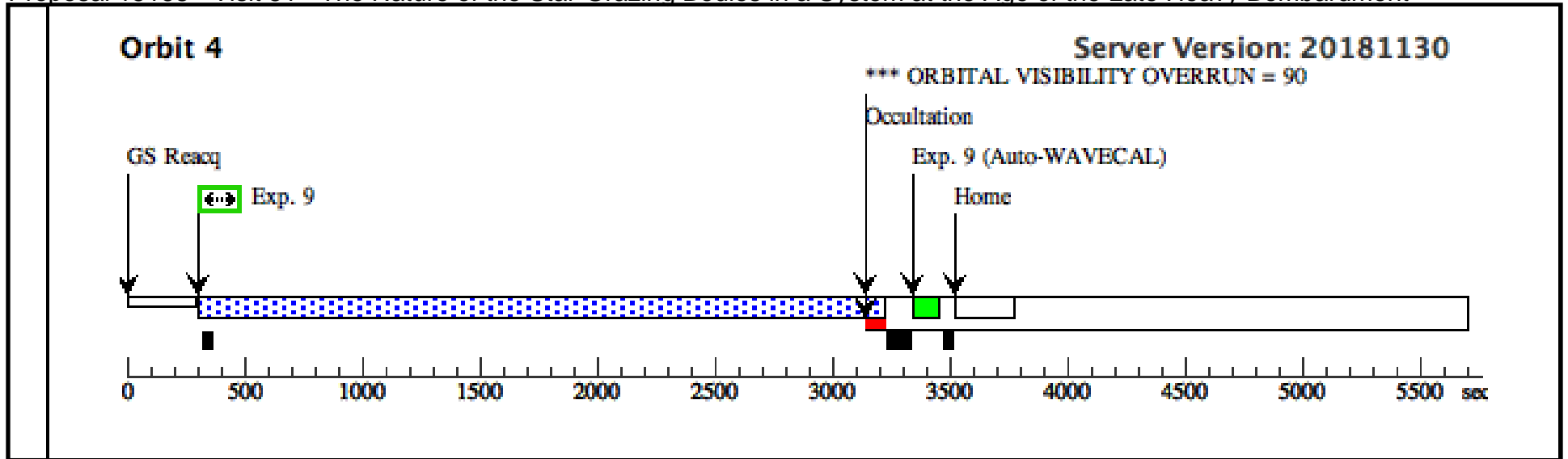

Proposal 15168 - Visit 53 - The Nature of the Star-Grazing Bodies in a System at the Age of the Late Heavy Bombardment

Tue Dec 18 18:01:24 GMT 2018

Visit	Proposal 15168, Visit 53, completed Diagnostic Status: Warning Scientific Instruments: COS/FUV Special Requirements: AFTER 51 BY 0 Orbits TO 4.1 Orbits									
	(Visit 53) Warning (Form): For the best data quality, it is strongly recommended that the maximum number of allowed FP-POS positions is used when observing at a given COS CENWAVE setting. See full description for details. (Visit 53) Warning (Orbit Planner): ORBITAL VISIBILITY OVERRUN (Visit 53) Warning (Orbit Planner): ORBITAL VISIBILITY OVERRUN									
Diagnosics										
Fixed Targets	#	Name	Target Coordinates	Targ. Coord. Corrections	Fluxes	Miscellaneous				
	(1)	-PHI-LEO Alt Name1: HD-98058 Alt Name2: HIP-55084	RA: 11 16 39.6996 (169.1654150d) Dec: -03 39 5.78 (-3.65161d) Equinox: J2000	Proper Motion RA: -110.37 mas/yr Proper Motion Dec: -37.16 mas/yr Parallax: 0.01771" Epoch of Position: 2000 Radial Velocity: -3.0 km/sec	V=4.45+/-0.009 F(2655)=3E-11 erg/cm/cm/s/A (IUE LWP 27899)	Reference Frame: ICRS				
<i>Comments: This object was generated by the targetselector and retrieved from the SIMBAD database.</i> IUE data exist, for both the FUV and NUV, but large aperture data are available only in the NUV. Category=STAR Description=[A4-A9 V-IV, CIRCUMSTELLAR MATTER, CORONA, DISK, EXTRA-SOLAR PLANETARY SYSTEM] Extended=NO										
Exposures	#	Label (ETC Run)	Target	Config,Mode,Aperture	Spectral Els.	Opt. Params.	Special Reqs.	Groups	Exp. Time (Total)/[Actual Dur.]	Orbit
	1	(COS.sa.100 7540)	(1) -PHI-LEO	COS/FUV, ACQ/SEARCH, PSA	G130M 1291 A	SCAN-SIZE=2			4 Secs (4 Secs) [==>]	[1]
	2	(COS.sa.100 7540)	(1) -PHI-LEO	COS/FUV, ACQ/PEAKXD, PSA	G130M 1291 A	NUM-POS=5			4 Secs (4 Secs) [==>]	[1]
	3	(COS.sa.100 7540)	(1) -PHI-LEO	COS/FUV, ACQ/PEAKD, PSA	G130M 1291 A	NUM-POS=5; STEP-SIZE=0.9			4 Secs (4 Secs) [==>]	[1]
	4	(COS.sp.100 7962)	(1) -PHI-LEO	COS/FUV, TIME-TAG, PSA	G130M 1291 A	BUFFER-TIME=70 0; FP-POS=3			2100 Secs (2218 Secs) [==>2218.0 Secs]	[1]
	5	(COS.sp.100 7962)	(1) -PHI-LEO	COS/FUV, TIME-TAG, PSA	G130M 1291 A	BUFFER-TIME=70 0; FP-POS=4			2900 Secs (2916 Secs) [==>2916.0 Secs]	[2]

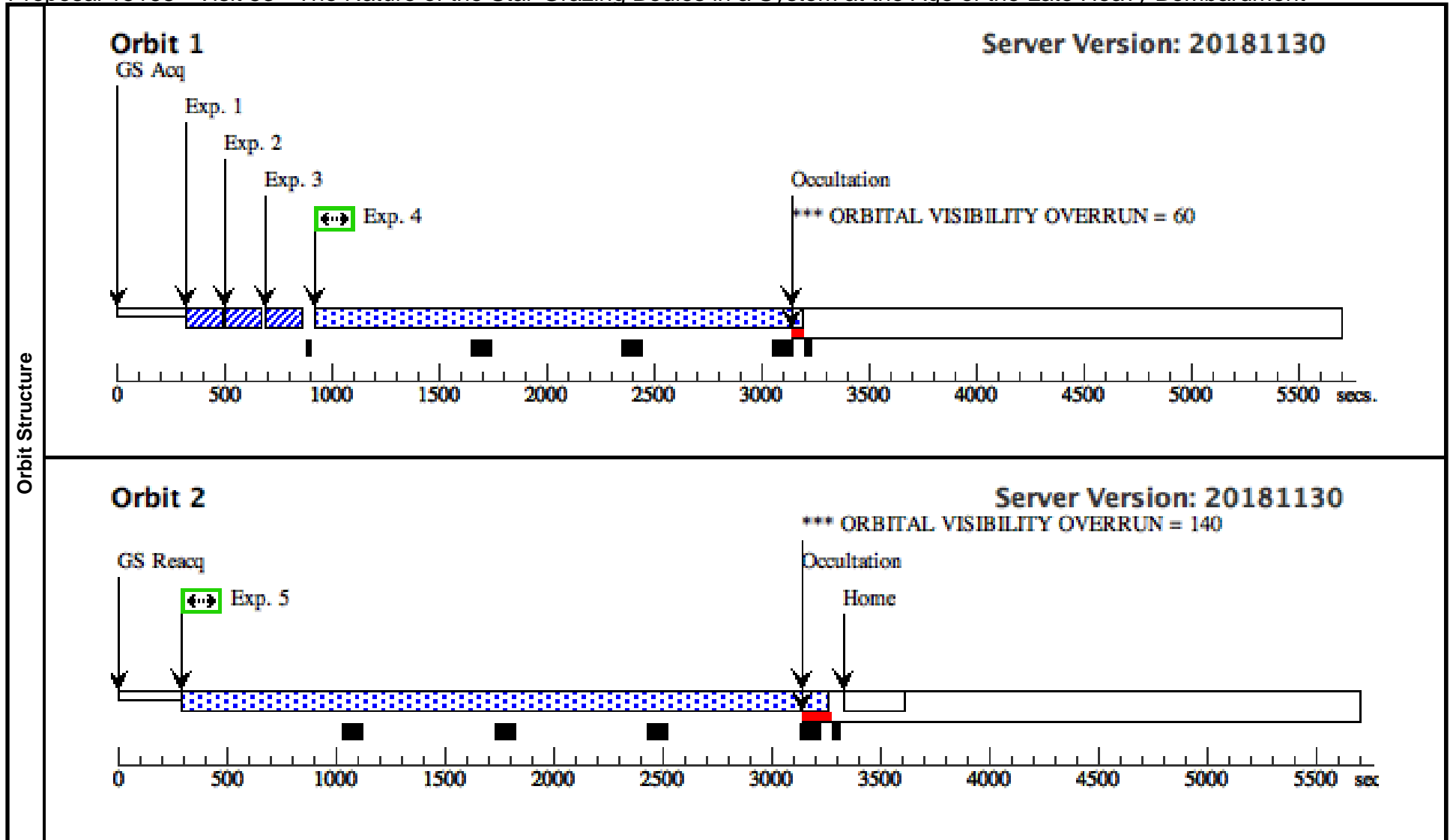

Proposal 15168 - Visit 54 - The Nature of the Star-Grazing Bodies in a System at the Age of the Late Heavy Bombardment

Tue Dec 18 18:01:25 GMT 2018

Visit	Proposal 15168, Visit 54, implementation Diagnostic Status: No Diagnostics Scientific Instruments: STIS/NUV-MAMA, STIS/CCD, STIS/FUV-MAMA Special Requirements: BETWEEN 2019.069:00:00:00 AND 10-MAY-2019:00:00:00																																													
	Fixed Targets	<table border="1"> <thead> <tr> <th>#</th> <th>Name</th> <th>Target Coordinates</th> <th>Targ. Coord. Corrections</th> <th>Fluxes</th> <th>Miscellaneous</th> </tr> </thead> <tbody> <tr> <td>(1)</td> <td>-PHI-LEO</td> <td>RA: 11 16 39.6996 (169.1654150d)</td> <td>Proper Motion RA: -110.37 mas/yr</td> <td>V=4.45+/-0.009</td> <td>Reference Frame: ICRS</td> </tr> <tr> <td></td> <td>Alt Name1: HD-98058</td> <td>Dec: -03 39 5.78 (-3.65161d)</td> <td>Proper Motion Dec: -37.16 mas/yr</td> <td>F(2655)=3E-11 erg/cm/cm/s/A (IUE LWP 27899)</td> <td></td> </tr> <tr> <td></td> <td>Alt Name2: HIP-55084</td> <td>Equinox: J2000</td> <td>Parallax: 0.01771"</td> <td></td> <td></td> </tr> <tr> <td></td> <td></td> <td></td> <td>Epoch of Position: 2000</td> <td></td> <td></td> </tr> <tr> <td></td> <td></td> <td></td> <td>Radial Velocity: -3.0 km/sec</td> <td></td> <td></td> </tr> </tbody> </table> <p><i>Comments: This object was generated by the targetselector and retrieved from the SIMBAD database.</i></p> <p><i>IUE data exist, for both the FUV and NUV, but large aperture data are available only in the NUV.</i></p> <p><i>Category=STAR</i> <i>Description=[A4-A9 V-IV, CIRCUMSTELLAR MATTER, CORONA, DISK, EXTRA-SOLAR PLANETARY SYSTEM]</i> <i>Extended=NO</i></p>										#	Name	Target Coordinates	Targ. Coord. Corrections	Fluxes	Miscellaneous	(1)	-PHI-LEO	RA: 11 16 39.6996 (169.1654150d)	Proper Motion RA: -110.37 mas/yr	V=4.45+/-0.009	Reference Frame: ICRS		Alt Name1: HD-98058	Dec: -03 39 5.78 (-3.65161d)	Proper Motion Dec: -37.16 mas/yr	F(2655)=3E-11 erg/cm/cm/s/A (IUE LWP 27899)			Alt Name2: HIP-55084	Equinox: J2000	Parallax: 0.01771"						Epoch of Position: 2000						Radial Velocity: -3.0 km/sec	
#		Name	Target Coordinates	Targ. Coord. Corrections	Fluxes	Miscellaneous																																								
(1)	-PHI-LEO	RA: 11 16 39.6996 (169.1654150d)	Proper Motion RA: -110.37 mas/yr	V=4.45+/-0.009	Reference Frame: ICRS																																									
	Alt Name1: HD-98058	Dec: -03 39 5.78 (-3.65161d)	Proper Motion Dec: -37.16 mas/yr	F(2655)=3E-11 erg/cm/cm/s/A (IUE LWP 27899)																																										
	Alt Name2: HIP-55084	Equinox: J2000	Parallax: 0.01771"																																											
			Epoch of Position: 2000																																											
			Radial Velocity: -3.0 km/sec																																											
Exposures	#	Label (ETC Run)	Target	Config,Mode,Aperture	Spectral Els.	Opt. Params.	Special Reqs.	Groups	Exp. Time (Total)/[Actual Dur.]	Orbit																																				
	1	(STIS.ta.100 5473)	(1) -PHI-LEO	STIS/CCD, ACQ, F25ND5	MIRROR				1.5 Secs (1.5 Secs)																																					
									[==>]	[1]																																				
	2	(STIS.sp.10 05483)	(1) -PHI-LEO	STIS/CCD, ACQ/PEAK, 0.2X0.09	G430M 5471 A				0.3 Secs (0.3 Secs)																																					
									[==>]	[1]																																				
	3	(STIS.sp.10 05483)	(1) -PHI-LEO	STIS/CCD, ACQ/PEAK, 0.1X0.03	G430M 5471 A				0.3 Secs (0.3 Secs)																																					
									[==>]	[1]																																				
	4	(STIS.sp.10 05542)	(1) -PHI-LEO	STIS/NUV-MAMA, ACCUM, 0.1X0.03	E230H 2762 A				170 Secs (170 Secs)																																					
									[==>]	[1]																																				
	5	(STIS.sp.10 05543)	(1) -PHI-LEO	STIS/NUV-MAMA, ACCUM, 0.1X0.03	E230H 2513 A				170 Secs (170 Secs)																																					
								[==>]	[1]																																					
6	(STIS.sp.10 05545)	(1) -PHI-LEO	STIS/NUV-MAMA, ACCUM, 0.2X0.2	E230H 1763 A				170 Secs (170 Secs)																																						
								[==>]	[1]																																					
7	(STIS.sp.90 5752)	(1) -PHI-LEO	STIS/FUV-MAMA, ACCUM, 0.2X0.2	E140M 1425 A				2700 Secs (2700 Secs)																																						
								[==>]	[2]																																					
8	(STIS.sp.90 5752)	(1) -PHI-LEO	STIS/FUV-MAMA, ACCUM, 52X0.5	G140M 1222 A				2700 Secs (2700 Secs)																																						
								[==>]	[3]																																					
9	(STIS.sp.10 06634)	(1) -PHI-LEO	STIS/FUV-MAMA, ACCUM, 52X0.5	G140M 1222 A				2700 Secs (2700 Secs)																																						
								[==>]	[4]																																					

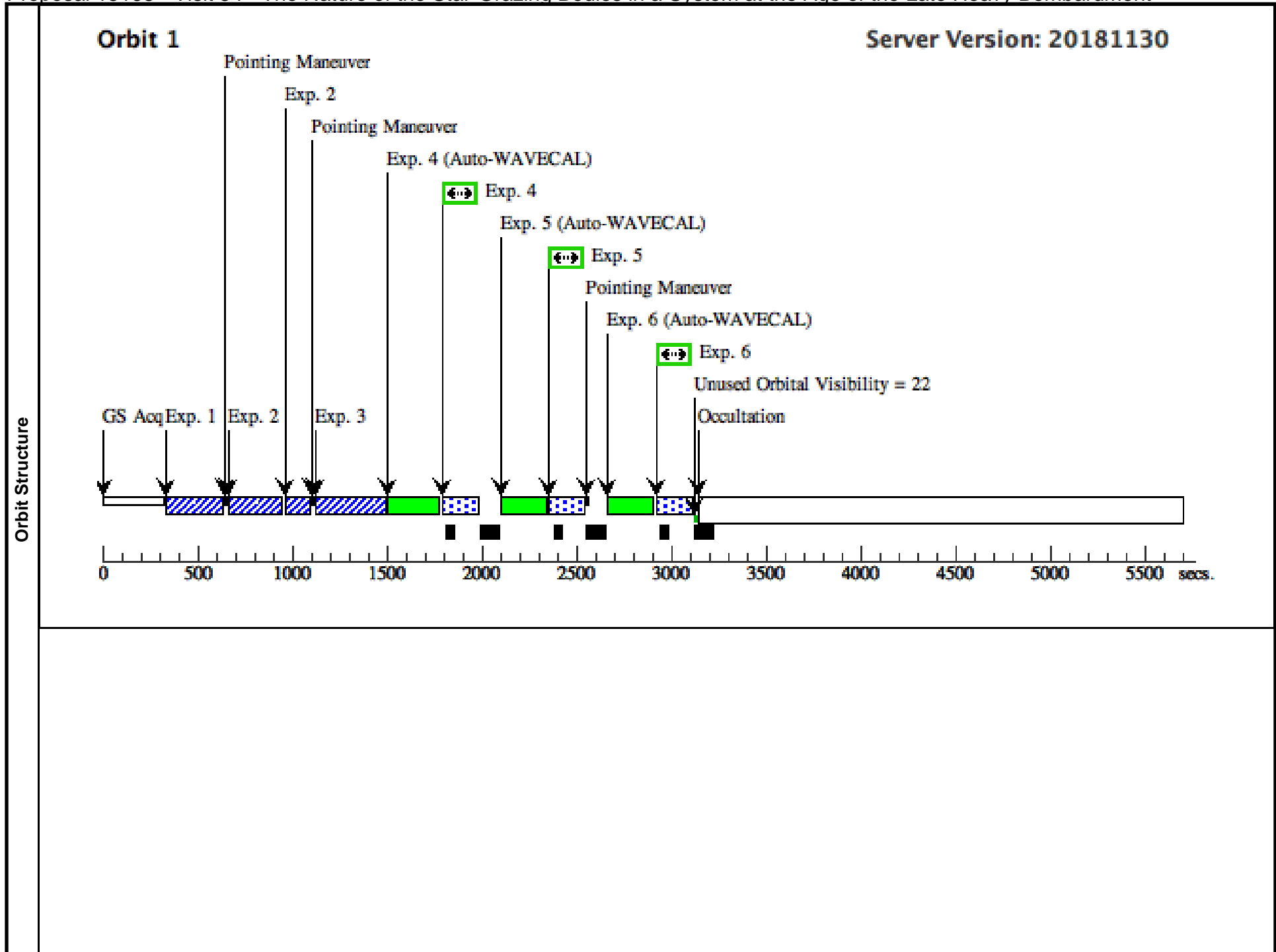

Orbit 2

Server Version: 20181130

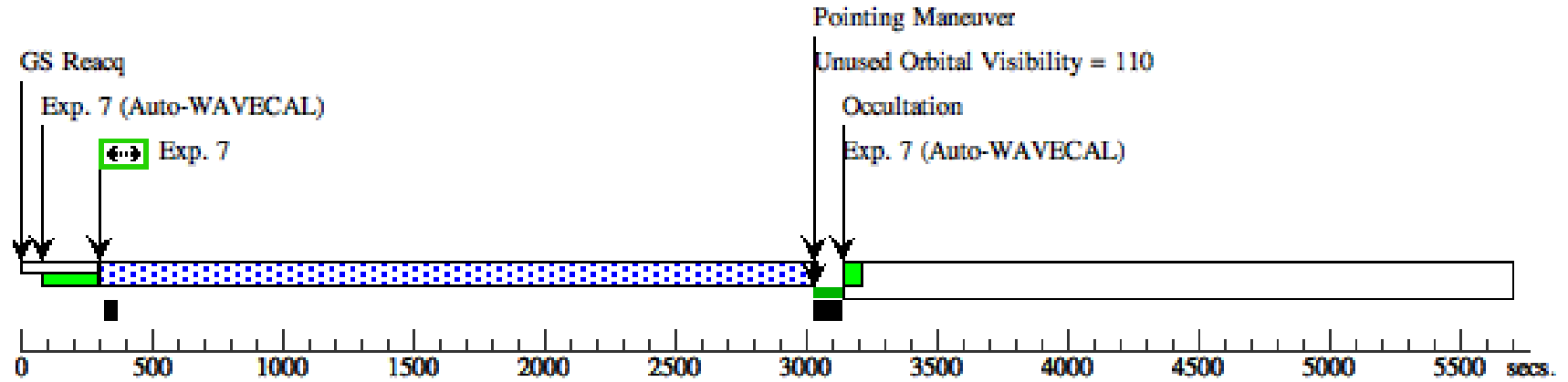

Orbit 3

Server Version: 20181130

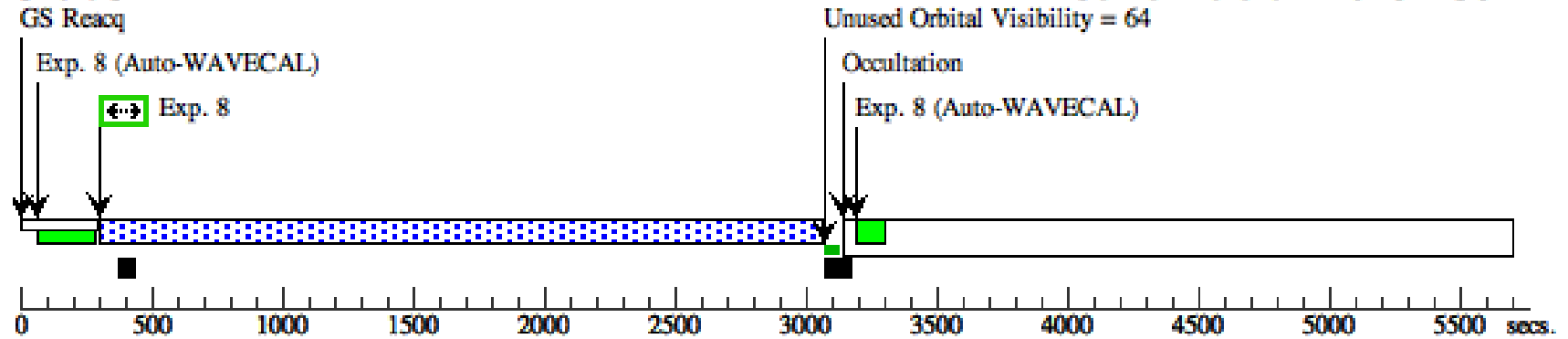

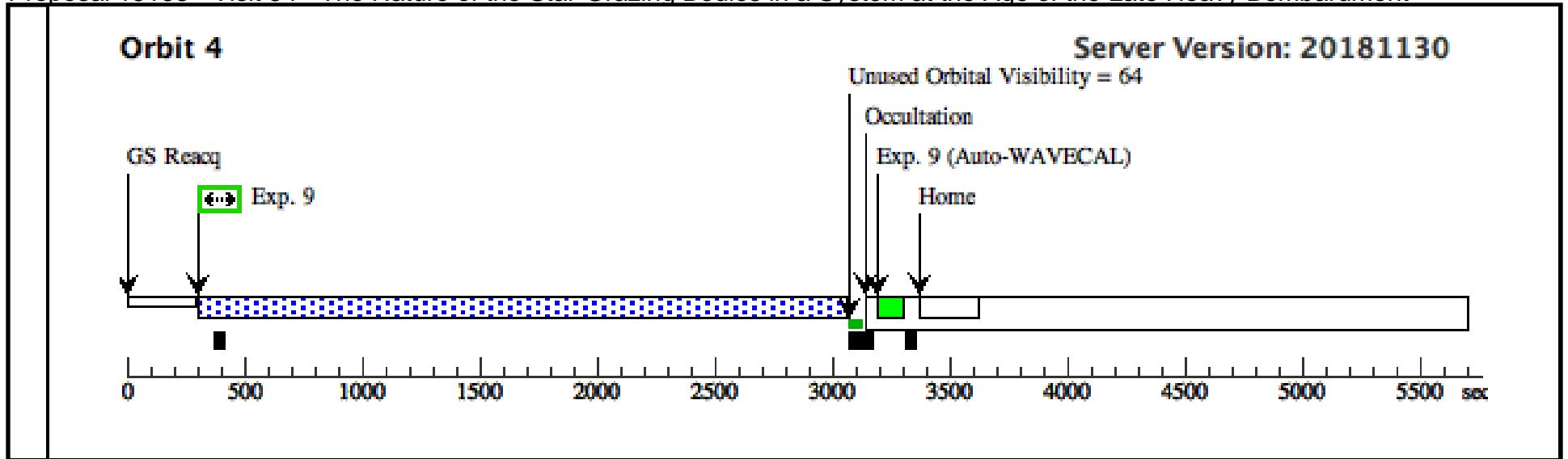

Proposal 15168 - Visit 55 - The Nature of the Star-Grazing Bodies in a System at the Age of the Late Heavy Bombardment

Tue Dec 18 18:01:25 GMT 2018

Visit	Proposal 15168, Visit 55, implementation Diagnostic Status: Warning Scientific Instruments: COS/FUV Special Requirements: AFTER 54 BY 0 Orbits TO 4.1 Orbits									
	(Visit 55) Warning (Form): For the best data quality, it is strongly recommended that the maximum number of allowed FP-POS positions is used when observing at a given COS CENWAVE setting. See full description for details.									
Diagnosics										
Fixed Targets	#	Name	Target Coordinates	Targ. Coord. Corrections		Fluxes	Miscellaneous			
	(1)	-PHI-LEO Alt Name1: HD-98058 Alt Name2: HIP-55084	RA: 11 16 39.6996 (169.1654150d) Dec: -03 39 5.78 (-3.65161d) Equinox: J2000	Proper Motion RA: -110.37 mas/yr Proper Motion Dec: -37.16 mas/yr Parallax: 0.01771" Epoch of Position: 2000 Radial Velocity: -3.0 km/sec	V=4.45+/-0.009		Reference Frame: ICRS F(2655)=3E-11 erg/cm/cm/s/A (IUE LWP 27899)			
Comments: This object was generated by the targetselector and retrieved from the SIMBAD database. IUE data exist, for both the FUV and NUV, but large aperture data are available only in the NUV. Category=STAR Description=[A4-A9 V-IV, CIRCUMSTELLAR MATTER, CORONA, DISK, EXTRA-SOLAR PLANETARY SYSTEM] Extended=NO										
Exposures	#	Label (ETC Run)	Target	Config,Mode,Aperture	Spectral Els.	Opt. Params.	Special Reqs.	Groups	Exp. Time (Total)/[Actual Dur.]	Orbit
	1	(COS.sa.100 7540)	(1) -PHI-LEO	COS/FUV, ACQ/SEARCH, PSA	G130M 1291 A	SCAN-SIZE=2			4 Secs (4 Secs) [==>]	[1]
	2	(COS.sa.100 7540)	(1) -PHI-LEO	COS/FUV, ACQ/PEAKXD, PSA	G130M 1291 A	NUM-POS=5			4 Secs (4 Secs) [==>]	[1]
	3	(COS.sa.100 7540)	(1) -PHI-LEO	COS/FUV, ACQ/PEAKD, PSA	G130M 1291 A	NUM-POS=5; STEP-SIZE=0.9			4 Secs (4 Secs) [==>]	[1]
	4	(COS.sp.100 7962)	(1) -PHI-LEO	COS/FUV, TIME-TAG, PSA	G130M 1291 A	BUFFER-TIME=70 0; FP-POS=3			1599 Secs (2158 Secs) [==>2158.0 Secs]	[1]
	5	(COS.sp.100 7962)	(1) -PHI-LEO	COS/FUV, TIME-TAG, PSA	G130M 1291 A	BUFFER-TIME=70 0; FP-POS=4			2900 Secs (2776 Secs) [==>2776.0 Secs]	[2]

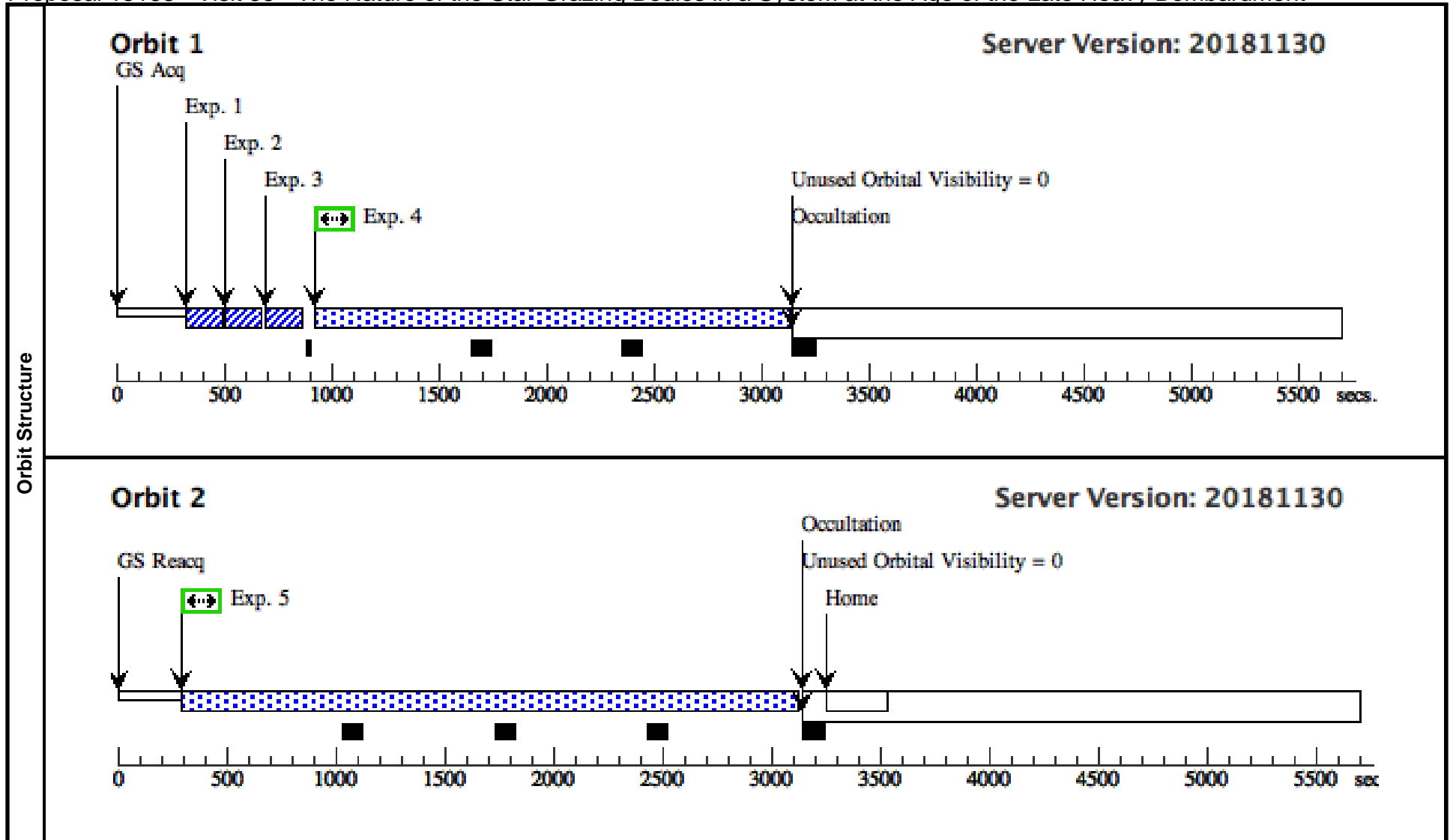

Proposal 15168 - Visit 56 - The Nature of the Star-Grazing Bodies in a System at the Age of the Late Heavy Bombardment

Tue Dec 18 18:01:25 GMT 2018

Visit	Proposal 15168, Visit 56, implementation Diagnostic Status: No Diagnostics Scientific Instruments: STIS/NUV-MAMA, STIS/CCD, STIS/FUV-MAMA Special Requirements: AFTER 55 BY 10 D TO 14 D Comments: Repeat of Visit 51, which was a repeat of Visit 01																																																																																																																																																																																																							
	Fixed Targets	<table border="1"> <thead> <tr> <th>#</th> <th>Name</th> <th>Target Coordinates</th> <th>Targ. Coord. Corrections</th> <th>Fluxes</th> <th>Miscellaneous</th> </tr> </thead> <tbody> <tr> <td>(1)</td> <td>-PHI-LEO</td> <td>RA: 11 16 39.6996 (169.1654150d)</td> <td>Proper Motion RA: -110.37 mas/yr</td> <td>V=4.45+/-0.009</td> <td>Reference Frame: ICRS</td> </tr> <tr> <td></td> <td>Alt Name1: HD-98058</td> <td>Dec: -03 39 5.78 (-3.65161d)</td> <td>Proper Motion Dec: -37.16 mas/yr</td> <td>F(2655)=3E-11 erg/cm/cm/s/A (IUE LWP 27899)</td> <td></td> </tr> <tr> <td></td> <td>Alt Name2: HIP-55084</td> <td>Equinox: J2000</td> <td>Parallax: 0.01771"</td> <td></td> <td></td> </tr> <tr> <td></td> <td></td> <td></td> <td>Epoch of Position: 2000</td> <td></td> <td></td> </tr> <tr> <td></td> <td></td> <td></td> <td>Radial Velocity: -3.0 km/sec</td> <td></td> <td></td> </tr> </tbody> </table> <p>Comments: This object was generated by the targetselector and retrieved from the SIMBAD database.</p> <p>IUE data exist, for both the FUV and NUV, but large aperture data are available only in the NUV.</p> <p>Category=STAR Description=[A4-A9 V-IV, CIRCUMSTELLAR MATTER, CORONA, DISK, EXTRA-SOLAR PLANETARY SYSTEM] Extended=NO</p>					#	Name	Target Coordinates	Targ. Coord. Corrections	Fluxes	Miscellaneous	(1)	-PHI-LEO	RA: 11 16 39.6996 (169.1654150d)	Proper Motion RA: -110.37 mas/yr	V=4.45+/-0.009	Reference Frame: ICRS		Alt Name1: HD-98058	Dec: -03 39 5.78 (-3.65161d)	Proper Motion Dec: -37.16 mas/yr	F(2655)=3E-11 erg/cm/cm/s/A (IUE LWP 27899)			Alt Name2: HIP-55084	Equinox: J2000	Parallax: 0.01771"						Epoch of Position: 2000						Radial Velocity: -3.0 km/sec																																																																																																																																																																
#		Name	Target Coordinates	Targ. Coord. Corrections	Fluxes	Miscellaneous																																																																																																																																																																																																		
(1)	-PHI-LEO	RA: 11 16 39.6996 (169.1654150d)	Proper Motion RA: -110.37 mas/yr	V=4.45+/-0.009	Reference Frame: ICRS																																																																																																																																																																																																			
	Alt Name1: HD-98058	Dec: -03 39 5.78 (-3.65161d)	Proper Motion Dec: -37.16 mas/yr	F(2655)=3E-11 erg/cm/cm/s/A (IUE LWP 27899)																																																																																																																																																																																																				
	Alt Name2: HIP-55084	Equinox: J2000	Parallax: 0.01771"																																																																																																																																																																																																					
			Epoch of Position: 2000																																																																																																																																																																																																					
			Radial Velocity: -3.0 km/sec																																																																																																																																																																																																					
Exposures	<table border="1"> <thead> <tr> <th>#</th> <th>Label (ETC Run)</th> <th>Target</th> <th>Config,Mode,Aperture</th> <th>Spectral Els.</th> <th>Opt. Params.</th> <th>Special Reqs.</th> <th>Groups</th> <th>Exp. Time (Total)/[Actual Dur.]</th> <th>Orbit</th> </tr> </thead> <tbody> <tr> <td>1</td> <td>(STIS.ta.100 5473)</td> <td>(1) -PHI-LEO</td> <td>STIS/CCD, ACQ, F25ND5</td> <td>MIRROR</td> <td></td> <td></td> <td></td> <td>1.5 Secs (1.5 Secs)</td> <td></td> </tr> <tr> <td></td> <td></td> <td></td> <td></td> <td></td> <td></td> <td></td> <td></td> <td>[==>]</td> <td>[1]</td> </tr> <tr> <td>2</td> <td>(STIS.sp.10 05483)</td> <td>(1) -PHI-LEO</td> <td>STIS/CCD, ACQ/PEAK, 0.2X0.09</td> <td>G430M</td> <td></td> <td></td> <td></td> <td>0.3 Secs (0.3 Secs)</td> <td></td> </tr> <tr> <td></td> <td></td> <td></td> <td></td> <td>5471 A</td> <td></td> <td></td> <td></td> <td>[==>]</td> <td>[1]</td> </tr> <tr> <td>3</td> <td>(STIS.sp.10 05483)</td> <td>(1) -PHI-LEO</td> <td>STIS/CCD, ACQ/PEAK, 0.1X0.03</td> <td>G430M</td> <td></td> <td></td> <td></td> <td>0.3 Secs (0.3 Secs)</td> <td></td> </tr> <tr> <td></td> <td></td> <td></td> <td></td> <td>5471 A</td> <td></td> <td></td> <td></td> <td>[==>]</td> <td>[1]</td> </tr> <tr> <td>4</td> <td>(STIS.sp.10 05542)</td> <td>(1) -PHI-LEO</td> <td>STIS/NUV-MAMA, ACCUM, 0.1X0.03</td> <td>E230H</td> <td></td> <td></td> <td></td> <td>170 Secs (177 Secs)</td> <td></td> </tr> <tr> <td></td> <td></td> <td></td> <td></td> <td>2762 A</td> <td></td> <td></td> <td></td> <td>[==>177.0 Secs]</td> <td>[1]</td> </tr> <tr> <td>5</td> <td>(STIS.sp.10 05543)</td> <td>(1) -PHI-LEO</td> <td>STIS/NUV-MAMA, ACCUM, 0.1X0.03</td> <td>E230H</td> <td></td> <td></td> <td></td> <td>170 Secs (177 Secs)</td> <td></td> </tr> <tr> <td></td> <td></td> <td></td> <td></td> <td>2513 A</td> <td></td> <td></td> <td></td> <td>[==>177.0 Secs]</td> <td>[1]</td> </tr> <tr> <td>6</td> <td>(STIS.sp.10 05545)</td> <td>(1) -PHI-LEO</td> <td>STIS/NUV-MAMA, ACCUM, 0.2X0.2</td> <td>E230H</td> <td></td> <td></td> <td></td> <td>170 Secs (177 Secs)</td> <td></td> </tr> <tr> <td></td> <td></td> <td></td> <td></td> <td>1763 A</td> <td></td> <td></td> <td></td> <td>[==>177.0 Secs]</td> <td>[1]</td> </tr> <tr> <td>7</td> <td>(STIS.sp.90 5752)</td> <td>(1) -PHI-LEO</td> <td>STIS/FUV-MAMA, ACCUM, 0.2X0.2</td> <td>E140M</td> <td></td> <td></td> <td></td> <td>2900 Secs (2810 Secs)</td> <td></td> </tr> <tr> <td></td> <td></td> <td></td> <td></td> <td>1425 A</td> <td></td> <td></td> <td></td> <td>[==>2810.0 Secs]</td> <td>[2]</td> </tr> <tr> <td>8</td> <td>(STIS.sp.90 5752)</td> <td>(1) -PHI-LEO</td> <td>STIS/FUV-MAMA, ACCUM, 52X0.5</td> <td>G140M</td> <td></td> <td></td> <td></td> <td>2950 Secs (2764 Secs)</td> <td></td> </tr> <tr> <td></td> <td></td> <td></td> <td></td> <td>1222 A</td> <td></td> <td></td> <td></td> <td>[==>2764.0 Secs]</td> <td>[3]</td> </tr> <tr> <td>9</td> <td>(STIS.sp.10 06634)</td> <td>(1) -PHI-LEO</td> <td>STIS/FUV-MAMA, ACCUM, 52X0.5</td> <td>G140M</td> <td></td> <td></td> <td></td> <td>2900 Secs (2764 Secs)</td> <td></td> </tr> <tr> <td></td> <td></td> <td></td> <td></td> <td>1222 A</td> <td></td> <td></td> <td></td> <td>[==>2764.0 Secs]</td> <td>[4]</td> </tr> </tbody> </table>										#	Label (ETC Run)	Target	Config,Mode,Aperture	Spectral Els.	Opt. Params.	Special Reqs.	Groups	Exp. Time (Total)/[Actual Dur.]	Orbit	1	(STIS.ta.100 5473)	(1) -PHI-LEO	STIS/CCD, ACQ, F25ND5	MIRROR				1.5 Secs (1.5 Secs)										[==>]	[1]	2	(STIS.sp.10 05483)	(1) -PHI-LEO	STIS/CCD, ACQ/PEAK, 0.2X0.09	G430M				0.3 Secs (0.3 Secs)						5471 A				[==>]	[1]	3	(STIS.sp.10 05483)	(1) -PHI-LEO	STIS/CCD, ACQ/PEAK, 0.1X0.03	G430M				0.3 Secs (0.3 Secs)						5471 A				[==>]	[1]	4	(STIS.sp.10 05542)	(1) -PHI-LEO	STIS/NUV-MAMA, ACCUM, 0.1X0.03	E230H				170 Secs (177 Secs)						2762 A				[==>177.0 Secs]	[1]	5	(STIS.sp.10 05543)	(1) -PHI-LEO	STIS/NUV-MAMA, ACCUM, 0.1X0.03	E230H				170 Secs (177 Secs)						2513 A				[==>177.0 Secs]	[1]	6	(STIS.sp.10 05545)	(1) -PHI-LEO	STIS/NUV-MAMA, ACCUM, 0.2X0.2	E230H				170 Secs (177 Secs)						1763 A				[==>177.0 Secs]	[1]	7	(STIS.sp.90 5752)	(1) -PHI-LEO	STIS/FUV-MAMA, ACCUM, 0.2X0.2	E140M				2900 Secs (2810 Secs)						1425 A				[==>2810.0 Secs]	[2]	8	(STIS.sp.90 5752)	(1) -PHI-LEO	STIS/FUV-MAMA, ACCUM, 52X0.5	G140M				2950 Secs (2764 Secs)						1222 A				[==>2764.0 Secs]	[3]	9	(STIS.sp.10 06634)	(1) -PHI-LEO	STIS/FUV-MAMA, ACCUM, 52X0.5	G140M				2900 Secs (2764 Secs)						1222 A				[==>2764.0 Secs]	[4]
	#	Label (ETC Run)	Target	Config,Mode,Aperture	Spectral Els.	Opt. Params.	Special Reqs.	Groups	Exp. Time (Total)/[Actual Dur.]	Orbit																																																																																																																																																																																														
	1	(STIS.ta.100 5473)	(1) -PHI-LEO	STIS/CCD, ACQ, F25ND5	MIRROR				1.5 Secs (1.5 Secs)																																																																																																																																																																																															
									[==>]	[1]																																																																																																																																																																																														
	2	(STIS.sp.10 05483)	(1) -PHI-LEO	STIS/CCD, ACQ/PEAK, 0.2X0.09	G430M				0.3 Secs (0.3 Secs)																																																																																																																																																																																															
					5471 A				[==>]	[1]																																																																																																																																																																																														
	3	(STIS.sp.10 05483)	(1) -PHI-LEO	STIS/CCD, ACQ/PEAK, 0.1X0.03	G430M				0.3 Secs (0.3 Secs)																																																																																																																																																																																															
					5471 A				[==>]	[1]																																																																																																																																																																																														
	4	(STIS.sp.10 05542)	(1) -PHI-LEO	STIS/NUV-MAMA, ACCUM, 0.1X0.03	E230H				170 Secs (177 Secs)																																																																																																																																																																																															
					2762 A				[==>177.0 Secs]	[1]																																																																																																																																																																																														
5	(STIS.sp.10 05543)	(1) -PHI-LEO	STIS/NUV-MAMA, ACCUM, 0.1X0.03	E230H				170 Secs (177 Secs)																																																																																																																																																																																																
				2513 A				[==>177.0 Secs]	[1]																																																																																																																																																																																															
6	(STIS.sp.10 05545)	(1) -PHI-LEO	STIS/NUV-MAMA, ACCUM, 0.2X0.2	E230H				170 Secs (177 Secs)																																																																																																																																																																																																
				1763 A				[==>177.0 Secs]	[1]																																																																																																																																																																																															
7	(STIS.sp.90 5752)	(1) -PHI-LEO	STIS/FUV-MAMA, ACCUM, 0.2X0.2	E140M				2900 Secs (2810 Secs)																																																																																																																																																																																																
				1425 A				[==>2810.0 Secs]	[2]																																																																																																																																																																																															
8	(STIS.sp.90 5752)	(1) -PHI-LEO	STIS/FUV-MAMA, ACCUM, 52X0.5	G140M				2950 Secs (2764 Secs)																																																																																																																																																																																																
				1222 A				[==>2764.0 Secs]	[3]																																																																																																																																																																																															
9	(STIS.sp.10 06634)	(1) -PHI-LEO	STIS/FUV-MAMA, ACCUM, 52X0.5	G140M				2900 Secs (2764 Secs)																																																																																																																																																																																																
				1222 A				[==>2764.0 Secs]	[4]																																																																																																																																																																																															

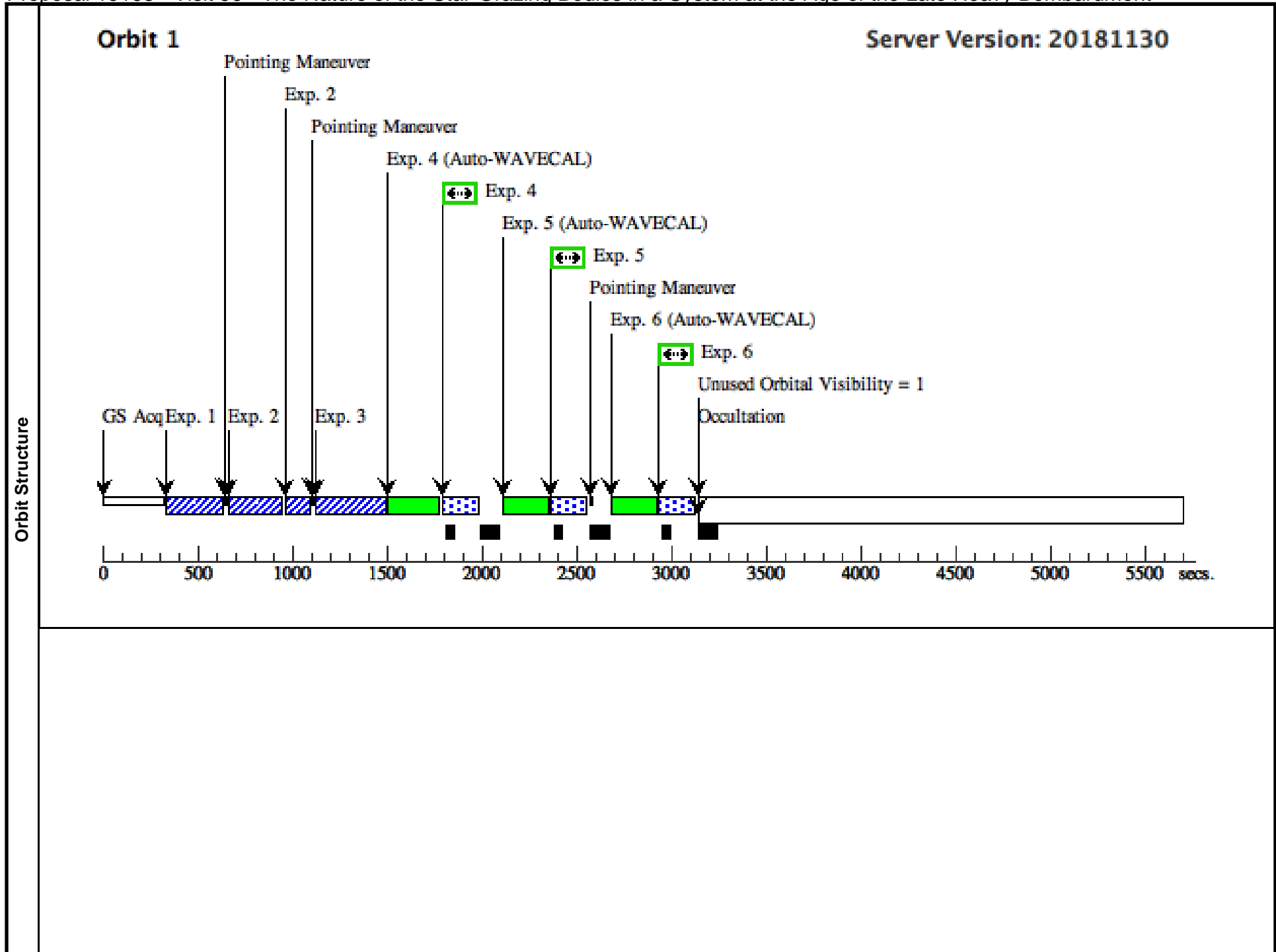

Orbit 2

Server Version: 20181130

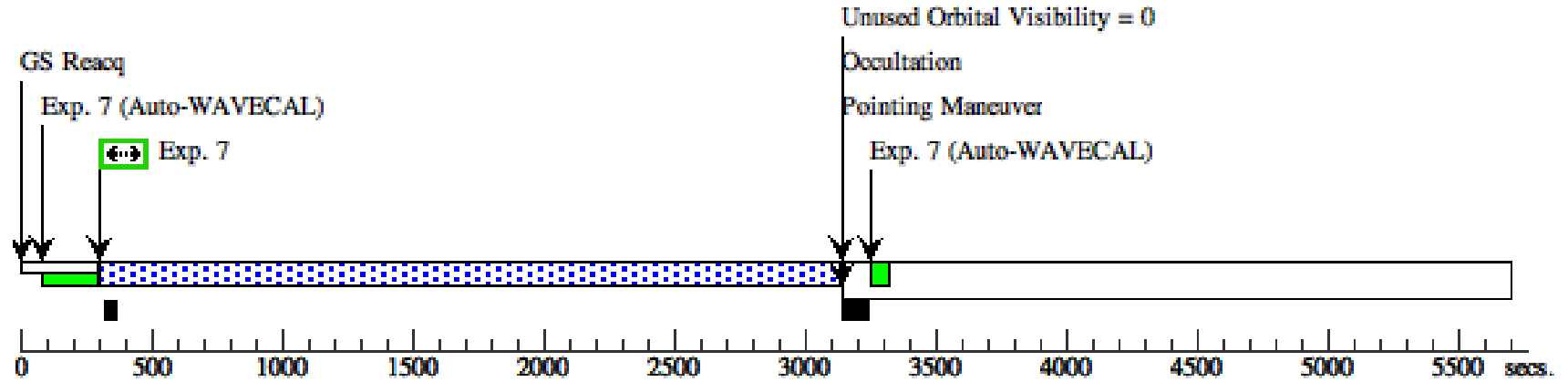

Orbit 3

Server Version: 20181130

