



# 15179 - Astrophysics Meets Atomic Physics: Fe I Line Identifications and Templates for Old Stellar Populations from Warm and Hot Stellar UV Spectra

Cycle: 25, Proposal Category: GO

(UV Initiative)

(Availability Mode: SUPPORTED)

## INVESTIGATORS

<i>Name</i>	<i>Institution</i>	<i>E-Mail</i>
<b>Dr. Ruth C. Peterson (PI) (Contact)</b>	<b>SETI Institute</b>	<b>peterson@ucolick.org</b>
Dr. Robert L. Kurucz (CoI)	Smithsonian Institution Astrophysical Observatory	rkurucz@cfa.harvard.edu
Dr. Thomas R. Ayres (CoI) (Contact)	University of Colorado at Boulder	thomas.ayres@colorado.edu

## VISITS

<i>Visit</i>	<i>Targets used in Visit</i>	<i>Configurations used in Visit</i>	<i>Orbits Used</i>	<i>Last Orbit Planner Run</i>	<i>OP Current with Visit?</i>
A0	(1) HD-72660	STIS/CCD STIS/NUV-MAMA	2	10-Dec-2018 20:00:54.0	yes
B0	(2) HD-84937	STIS/CCD STIS/NUV-MAMA	3	10-Dec-2018 20:00:55.0	yes
B1	(2) HD-84937	STIS/CCD STIS/NUV-MAMA	3	10-Dec-2018 20:00:57.0	yes
B2	(2) HD-84937	STIS/CCD STIS/NUV-MAMA	3	10-Dec-2018 20:00:58.0	yes
B3	(2) HD-84937	STIS/CCD STIS/NUV-MAMA	3	10-Dec-2018 20:00:59.0	yes

Proposal 15179 (STScI Edit Number: 2, Created: Monday, December 10, 2018 at 8:01:16 PM Eastern Standard Time) - Overview

<i>Visit</i>	<i>Targets used in Visit</i>	<i>Configurations used in Visit</i>	<i>Orbits Used</i>	<i>Last Orbit Planner Run</i>	<i>OP Current with Visit?</i>
B4	(2) HD-84937	STIS/CCD STIS/NUV-MAMA	3	10-Dec-2018 20:01:01.0	yes
B5	(2) HD-84937	STIS/CCD STIS/NUV-MAMA	3	10-Dec-2018 20:01:02.0	yes
C0	(3) HD-86986	STIS/CCD STIS/NUV-MAMA	3	10-Dec-2018 20:01:03.0	yes
C1	(3) HD-86986	STIS/CCD STIS/NUV-MAMA	3	10-Dec-2018 20:01:05.0	yes
C2	(3) HD-86986	STIS/CCD STIS/NUV-MAMA	3	10-Dec-2018 20:01:06.0	yes
C3	(3) HD-86986	STIS/CCD STIS/NUV-MAMA	3	10-Dec-2018 20:01:08.0	yes
C4	(3) HD-86986	STIS/CCD STIS/NUV-MAMA	3	10-Dec-2018 20:01:09.0	yes
C5	(3) HD-86986	STIS/CCD STIS/NUV-MAMA	3	10-Dec-2018 20:01:10.0	yes
C6	(3) HD-86986	STIS/CCD STIS/NUV-MAMA	3	10-Dec-2018 20:01:11.0	yes
C7	(3) HD-86986	STIS/CCD STIS/NUV-MAMA	3	10-Dec-2018 20:01:12.0	yes
C8	(3) HD-86986	STIS/CCD STIS/NUV-MAMA	3	10-Dec-2018 20:01:13.0	yes
C9	(3) HD-86986	STIS/CCD STIS/NUV-MAMA	3	10-Dec-2018 20:01:15.0	yes
D0	(4) HD-128167	STIS/CCD STIS/NUV-MAMA	2	10-Dec-2018 20:01:16.0	yes

52 Total Orbits Used

## **ABSTRACT**

Imaging surveys from the ultraviolet to the infrared are recording ever more distant astronomical sources. Needed to interpret them are high-resolution ultraviolet spectral templates at all metallicities for both old and intermediate-age stars, and the atomic physics data essential to model their spectra. To this end we are proposing new UV spectra of four warm and hot stars spanning a wide range of metallicity. These will provide observational templates of old and young metal-poor turnoff stars, and the "laboratory source" for the identification of thousands of lines of neutral iron that appear in stellar spectra but are not identified in laboratory spectra. By matching existing and new stellar spectra to calculations of energy levels, line wavelengths, and gf-values, Peterson & Kurucz (2015) and Peterson, Kurucz, & Ayres (2017) identified 124 Fe I levels with energies up to 8.4eV. These provided ~3000 detectable Fe I lines from 1600Å to 5.4 $\mu$ , and yielded empirical gf-values for 640 of these. Here we propose high-resolution UV spectra reaching 1780Å for the first time at the turnoff, to detect and identify the strongest Fe I lines at 1800 - 1850Å. This should add ~250 new Fe I levels. These spectra, plus one at lower resolution reaching 1620Å, will also provide empirical UV templates for turnoff stars at high redshifts as well as low. This is essential to deriving age and metallicity independently for globular clusters and old galaxies out to  $z \sim 3$ . It will also improve abundances of trace elements in metal-poor stars, constraining nucleosynthesis at early epochs and aiding the reconstruction of the populations of the Milky Way halo and of nearby globular clusters.

## **OBSERVING DESCRIPTION**

The observing program is straightforward. All of the targets have been observed previously, safely, by STIS, and all have sufficient STIS and IUE spectra to accurately characterize SEDs for use with the STIS spectroscopic ETC, despite having heavy-element abundances that range from 1/200 solar to twice solar. None of these stars are known to flare. None are known to be variable, including HD 128167, neither from its archival E230H spectra (GO 7433, PI Heap) nor from the photometric determination of its temperature (Paunzen et al. 2014, A&A, 567, A67). The use of narrow slits, and previous STIS and IUE NUV spectra, preclude possible interference from nearby stars. Target acquisitions initially are by the CCD, with the MIRROR and ND3 filter; exposure times are set to yield more than adequate counts. The narrow-slit peak-ups are performed in dispersed light with the low-res optical grating, G430L, and the CCD. The minimal (0.1 s) peak-up exposure time yields more than sufficient total counts while avoiding saturation of the spectral stripe. For the two brightest stars, the exposures at each E230H grating setting are broken into two segments, for safety and calibration purposes.

For all E230H spectra, our program uses standard E230H primary grating settings, completing NUV E230H spectral coverage to 1780Å for one very weak-lined turnoff star, and to various NUV limits for three hotter stars spanning a wide range of line strengths, as this is vital for Fe I identifications.

## Proposal 15179 (STScI Edit Number: 2, Created: Monday, December 10, 2018 at 8:01:16 PM Eastern Standard Time) - Overview

The longest E230H exposures are required to discern the thousand unidentified Fe I lines needed for the anticipated identification of ~250 new Fe I levels, and to weed out Fe II contaminants. For the brightest star HD 128167, the only mildly metal-poor, mildly-rotating early-F star with a STIS-accessible spectrum below 1880Å, our program completes its archival E230H coverage only to 2130Å with a standard c2263 spectrum, but adds a standard c1978 E230M spectrum blueward. The resulting coverage from 1730Å to 3140Å will provide the first empirical high-resolution NUV spectroscopic template for a hotter, mildly metal-poor star over this entire range, and will critically test whether our spectral modeling can reproduce its flux distribution. Both are required to discern diagnostics that can distinguish such younger, mildly metal-poor populations from older, more metal-poor systems at great distances, notably at high redshift with HST and JWST.

Because spectral resolution is critical to disentangle the formidable NUV line blends, the 0.2" x 0.09" slit will be used for all E230H spectra, and the 0.2" x 0.06" slit for the E230M spectrum. Our spectroscopic observations, and all but one of the NUV ETC spectroscopic runs, are adopted directly from Table 1 of the proposal's Description of Observations. IUE large-aperture LWR/P spectra of each target were used for the ETC normalizations of all E230H spectra. For the c1978 E230M ETC of HD 128167, whose SWP IUE spectra suffer many bad pixels, the ACQ/PEAK normalization was adopted instead. This yields an input ETC spectrum that agrees well with its LWR/P IUE spectra redward of 2100Å, where ~3/4 the total GCR originates.

Proposal 15179 - HD 72660 (A0) - Astrophysics Meets Atomic Physics: Fe I Line Identifications and Templates for Old Stellar Populati...

Tue Dec 11 01:01:16 GMT 2018

Visit	<b>Proposal 15179, HD 72660 (A0), implementation</b> <b>Diagnostic Status: No Diagnostics</b> Scientific Instruments: STIS/NUV-MAMA, STIS/CCD Special Requirements: (none)									
Fixed Targets	#	Name	Target Coordinates	Targ. Coord. Corrections		Fluxes	Miscellaneous			
	(1)	HD-72660	RA: 08 34 1.6182 (128.5067425d) Dec: -02 09 5.58 (-2.15155d) Equinox: J2000	Proper Motion RA: -32.55 mas/yr Proper Motion Dec: 22.26 mas/yr Parallax: 0.01107" Epoch of Position: 2000 Radial Velocity: +2.8 km/sec		V=5.792+/-1	Reference Frame: ICRS			
	<i>Comments: T<sub>eff</sub> = 9525, log g = 4.0, [Fe/H] = +0.35; metallic-lined A star</i> Category=STAR Description=[A0-A3 V-IV]									
Exposures	#	Label (ETC Run)	Target	Config,Mode,Aperture	Spectral Els.	Opt. Params.	Special Reqs.	Groups	Exp. Time (Total)/[Actual Dur.]	Orbit
	1	(STIS.ta.100 6162)	(1) HD-72660	STIS/CCD, ACQ, F25ND3	MIRROR				0.1 Secs (0.1 Secs) [==>]	[1]
	<i>Comments: Castelli-Kurucz Models A0V 9500 4.0; Renormalized to vegamag = 5.792 in filter Johnson/V; Time to Saturation (for a single exposure) = 2.40 seconds; 10,956 e- in 0.1s</i>									
	2	(STIS.sp.10 06176)	(1) HD-72660	STIS/CCD, ACQ/PEAK, 0.2X0.09	G430L 4300 A				0.1 Secs (0.1 Secs) [==>]	[1]
	<i>Comments: Castelli-Kurucz Models A0V 9500 4.0; Renormalized to vegamag = 5.792 in filter Johnson/V; Time to Saturation (for a single exposure) = 1.52 seconds; 3,399,674 e- in 0.1s</i>									
	3	(STIS.sp.91 8694)	(1) HD-72660	STIS/NUV-MAMA, ACCUM, 0.2X0.09	E230H 3012 A				836 Secs X 2 (1672 Secs) [==>(Copy 1)] [==>(Copy 2)]	[1]
	4	(STIS.sp.91 8692)	(1) HD-72660	STIS/NUV-MAMA, ACCUM, 0.2X0.09	E230H 2013 A				1336 Secs X 2 (2672 Secs) [==>(Copy 1)] [==>(Copy 2)]	[2]
	<i>Comments: GCR=80.4K; not a variable source</i>									

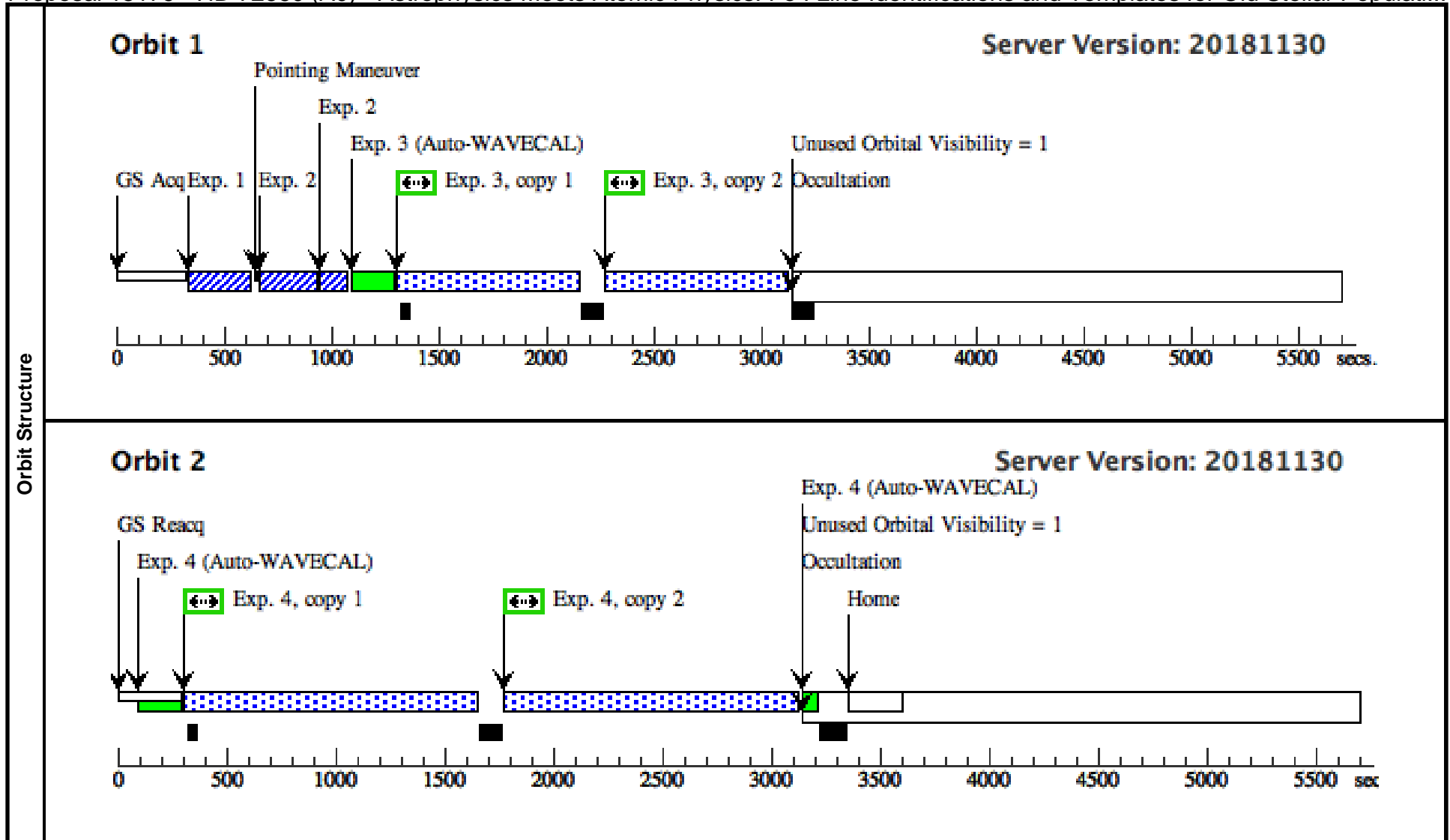

Proposal 15179 - HD 84937 (B0) - Astrophysics Meets Atomic Physics: Fe I Line Identifications and Templates for Old Stellar Populati...

Tue Dec 11 01:01:17 GMT 2018

Visit	<b>Proposal 15179, HD 84937 (B0), implementation</b> <b>Diagnostic Status: No Diagnostics</b> Scientific Instruments: STIS/NUV-MAMA, STIS/CCD Special Requirements: (none)										
	Fixed Targets	#	Name	Target Coordinates	Targ. Coord. Corrections	Fluxes	Miscellaneous				
		(2)	HD-84937	RA: 09 48 56.0980 (147.2337417d) Dec: +13 44 39.32 (13.74426d) Equinox: J2000	Proper Motion RA: +373.05 mas/yr Proper Motion Dec: -774.38 mas/yr Parallax: 0.01374" Epoch of Position: 2000 Radial Velocity: -15 km/sec	V=8.32+/-1	Reference Frame: ICRS				
	<i>Comments: T<sub>eff</sub> = 6300, log g = 4.0, [Fe/H] = -2.25; very metal-poor turnoff star</i> Category=STAR Description=[F3-F9]										
Exposures	#	Label (ETC Run)	Target	Config,Mode,Aperture	Spectral Els.	Opt. Params.	Special Reqs.	Groups	Exp. Time (Total)/[Actual Dur.]	Orbit	
	1	(STIS.ta.100 6207)	(2) HD-84937	STIS/CCD, ACQ, F25ND3	MIRROR				1 Secs (1 Secs)		
										[==>]	[1]
		<i>Comments: Castelli-Kurucz Models F2V 7000 4.0; Renormalized to vegamag = 8.32 in filter Johnson/V</i> Time to Saturation (for a single exposure) = 24.11 seconds; 11,507 e- in 1.0 s (Note: assumed spectral type differs from SIMBAD F8V owing to metal deficiency of star.)									
	2	(STIS.sp.10 06205)	(2) HD-84937	STIS/CCD, ACQ/PEAK, 0.2X0.09	G430L 4300 A				0.1 Secs (0.1 Secs)		
										[==>]	[1]
		<i>Comments: Castelli-Kurucz Models F2V 7000 4.0; Renormalized to vegamag = 8.32 in filter Johnson/V</i> Time to Saturation (for a single exposure) = 20.59 seconds; 267,396 e- in 0.1s (Note: assumed spectral type differs from SIMBAD F8V owing to metal deficiency of star.)									
3	(STIS.sp.91 9947)	(2) HD-84937	STIS/NUV-MAMA, ACCUM, 0.2X0.09	E230H 1763 A				1813 Secs (1813 Secs)			
									[==>]	[1]	
4	(STIS.sp.91 9947)	(2) HD-84937	STIS/NUV-MAMA, ACCUM, 0.2X0.09	E230H 1763 A				2817 Secs (2817 Secs)			
									[==>]	[2]	
5	(STIS.sp.91 9947)	(2) HD-84937	STIS/NUV-MAMA, ACCUM, 0.2X0.09	E230H 1763 A				2817 Secs (2817 Secs)			
									[==>]	[3]	

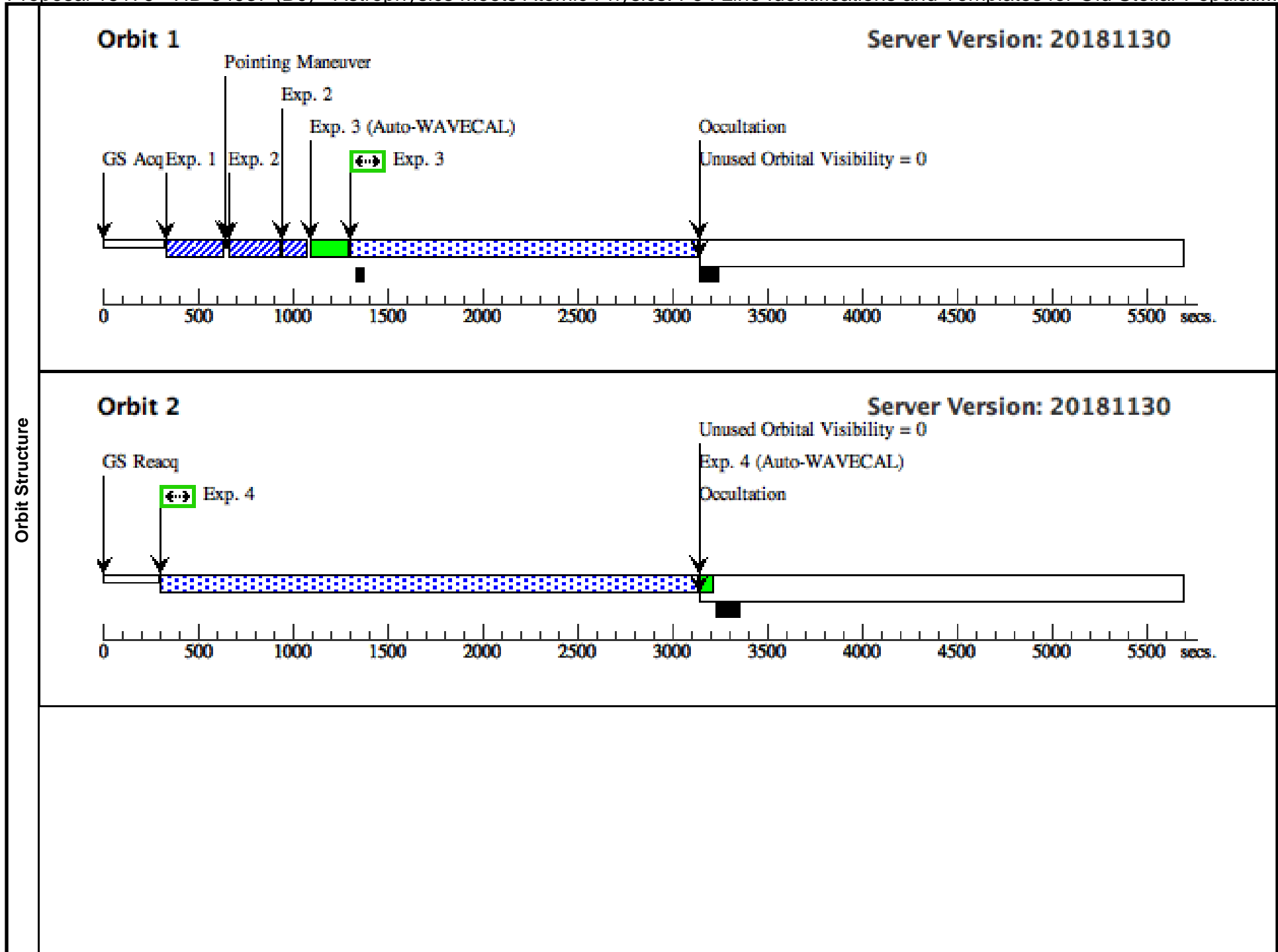

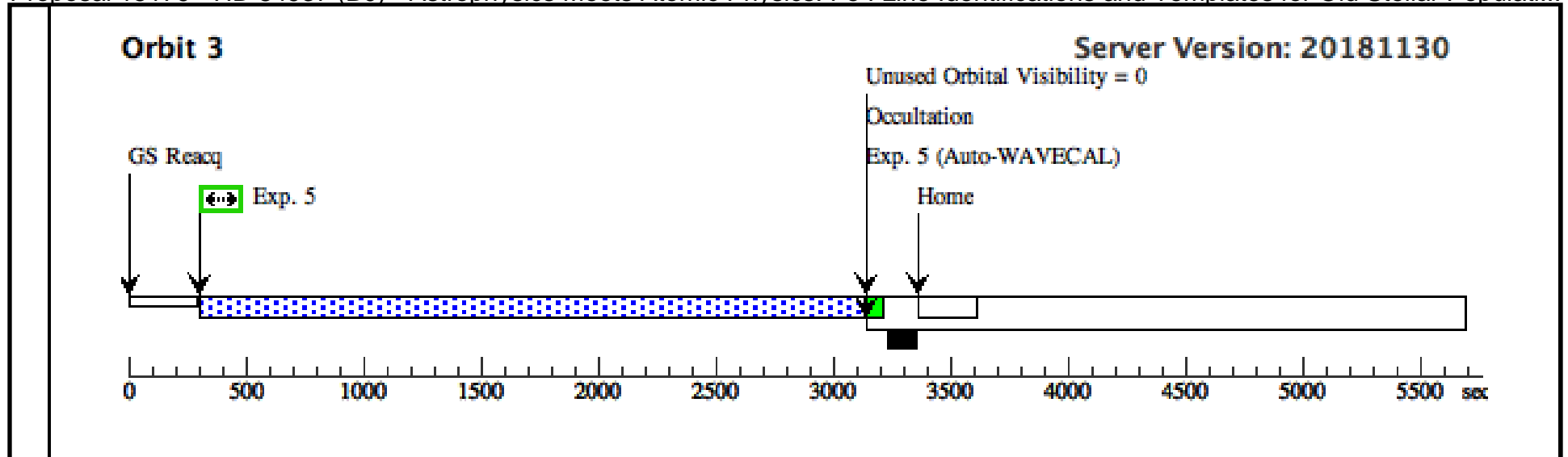

Proposal 15179 - HD 84937 (B1) - Astrophysics Meets Atomic Physics: Fe I Line Identifications and Templates for Old Stellar Populati...

Tue Dec 11 01:01:17 GMT 2018

Visit	<b>Proposal 15179, HD 84937 (B1), implementation</b> <b>Diagnostic Status: No Diagnostics</b> Scientific Instruments: STIS/NUV-MAMA, STIS/CCD Special Requirements: (none)										
	Fixed Targets	#	Name	Target Coordinates	Targ. Coord. Corrections	Fluxes	Miscellaneous				
		(2)	HD-84937	RA: 09 48 56.0980 (147.2337417d) Dec: +13 44 39.32 (13.74426d) Equinox: J2000	Proper Motion RA: +373.05 mas/yr Proper Motion Dec: -774.38 mas/yr Parallax: 0.01374" Epoch of Position: 2000 Radial Velocity: -15 km/sec	V=8.32+/-1	Reference Frame: ICRS				
	<i>Comments: T<sub>eff</sub> = 6300, log g = 4.0, [Fe/H] = -2.25; very metal-poor turnoff star</i> Category=STAR Description=[F3-F9]										
Exposures	#	Label (ETC Run)	Target	Config,Mode,Aperture	Spectral Els.	Opt. Params.	Special Reqs.	Groups	Exp. Time (Total)/[Actual Dur.]	Orbit	
	1	(STIS.ta.100 6207)	(2) HD-84937	STIS/CCD, ACQ, F25ND3	MIRROR				1 Secs (1 Secs)		
									[==>]	[1]	
		<i>Comments: Castelli-Kurucz Models F2V 7000 4.0; Renormalized to vegamag = 8.32 in filter Johnson/V</i> Time to Saturation (for a single exposure) = 24.11 seconds; 11,507 e- in 1.0 s (Note: assumed spectral type differs from SIMBAD F8V owing to metal deficiency of star.)									
	2	(STIS.sp.10 06205)	(2) HD-84937	STIS/CCD, ACQ/PEAK, 0.2X0.09	G430L 4300 A				0.1 Secs (0.1 Secs)		
									[==>]	[1]	
		<i>Comments: Castelli-Kurucz Models F2V 7000 4.0; Renormalized to vegamag = 8.32 in filter Johnson/V</i> Time to Saturation (for a single exposure) = 20.59 seconds; 267,396 e- in 0.1s (Note: assumed spectral type differs from SIMBAD F8V owing to metal deficiency of star.)									
3	(STIS.sp.91 9947)	(2) HD-84937	STIS/NUV-MAMA, ACCUM, 0.2X0.09	E230H 1763 A				1813 Secs (1813 Secs)			
								[==>]	[1]		
4	(STIS.sp.91 9947)	(2) HD-84937	STIS/NUV-MAMA, ACCUM, 0.2X0.09	E230H 1763 A				2817 Secs (2817 Secs)			
								[==>]	[2]		
5	(STIS.sp.91 9947)	(2) HD-84937	STIS/NUV-MAMA, ACCUM, 0.2X0.09	E230H 1763 A				2817 Secs (2817 Secs)			
								[==>]	[3]		

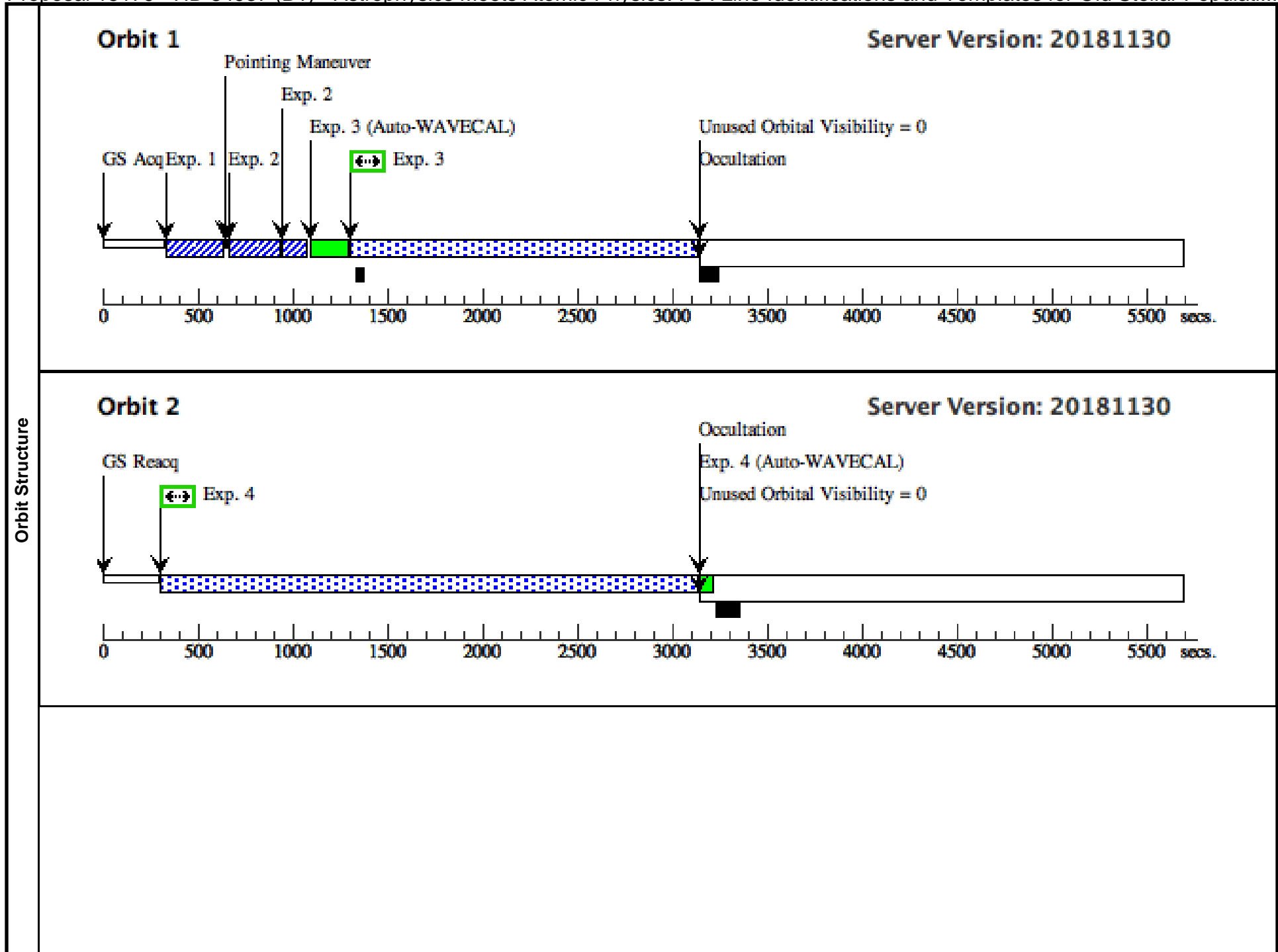

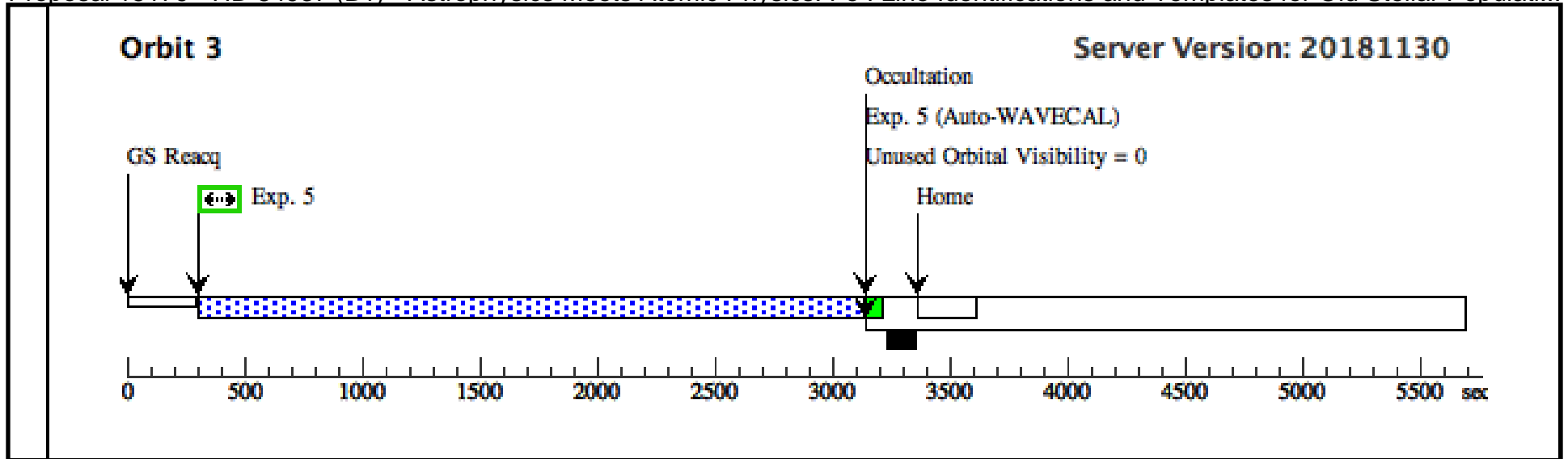

Proposal 15179 - HD 84937 (B2) - Astrophysics Meets Atomic Physics: Fe I Line Identifications and Templates for Old Stellar Populati...

Tue Dec 11 01:01:17 GMT 2018

Visit	<b>Proposal 15179, HD 84937 (B2), implementation</b> <b>Diagnostic Status: No Diagnostics</b> Scientific Instruments: STIS/NUV-MAMA, STIS/CCD Special Requirements: (none)										
	Fixed Targets	#	Name	Target Coordinates	Targ. Coord. Corrections	Fluxes	Miscellaneous				
		(2)	HD-84937	RA: 09 48 56.0980 (147.2337417d) Dec: +13 44 39.32 (13.74426d) Equinox: J2000	Proper Motion RA: +373.05 mas/yr Proper Motion Dec: -774.38 mas/yr Parallax: 0.01374" Epoch of Position: 2000 Radial Velocity: -15 km/sec	V=8.32+/-1	Reference Frame: ICRS				
	<i>Comments: T<sub>eff</sub> = 6300, log g = 4.0, [Fe/H] = -2.25; very metal-poor turnoff star</i> Category=STAR Description=[F3-F9]										
Exposures	#	Label (ETC Run)	Target	Config,Mode,Aperture	Spectral Els.	Opt. Params.	Special Reqs.	Groups	Exp. Time (Total)/[Actual Dur.]	Orbit	
	1	(STIS.ta.100 6207)	(2) HD-84937	STIS/CCD, ACQ, F25ND3	MIRROR				1 Secs (1 Secs)		
										[==>]	[1]
		<i>Comments: Castelli-Kurucz Models F2V 7000 4.0; Renormalized to vegamag = 8.32 in filter Johnson/V</i> Time to Saturation (for a single exposure) = 24.11 seconds; 11,507 e- in 1.0 s (Note: assumed spectral type differs from SIMBAD F8V owing to metal deficiency of star.)									
	2	(STIS.sp.10 06205)	(2) HD-84937	STIS/CCD, ACQ/PEAK, 0.2X0.09	G430L 4300 A				0.1 Secs (0.1 Secs)		
										[==>]	[1]
		<i>Comments: Castelli-Kurucz Models F2V 7000 4.0; Renormalized to vegamag = 8.32 in filter Johnson/V</i> Time to Saturation (for a single exposure) = 20.59 seconds; 267,396 e- in 0.1s (Note: assumed spectral type differs from SIMBAD F8V owing to metal deficiency of star.)									
3	(STIS.sp.91 9947)	(2) HD-84937	STIS/NUV-MAMA, ACCUM, 0.2X0.09	E230H 1763 A				1813 Secs (1813 Secs)			
									[==>]	[1]	
4	(STIS.sp.91 9947)	(2) HD-84937	STIS/NUV-MAMA, ACCUM, 0.2X0.09	E230H 1763 A				2817 Secs (2817 Secs)			
									[==>]	[2]	
5	(STIS.sp.91 9947)	(2) HD-84937	STIS/NUV-MAMA, ACCUM, 0.2X0.09	E230H 1763 A				2817 Secs (2817 Secs)			
									[==>]	[3]	

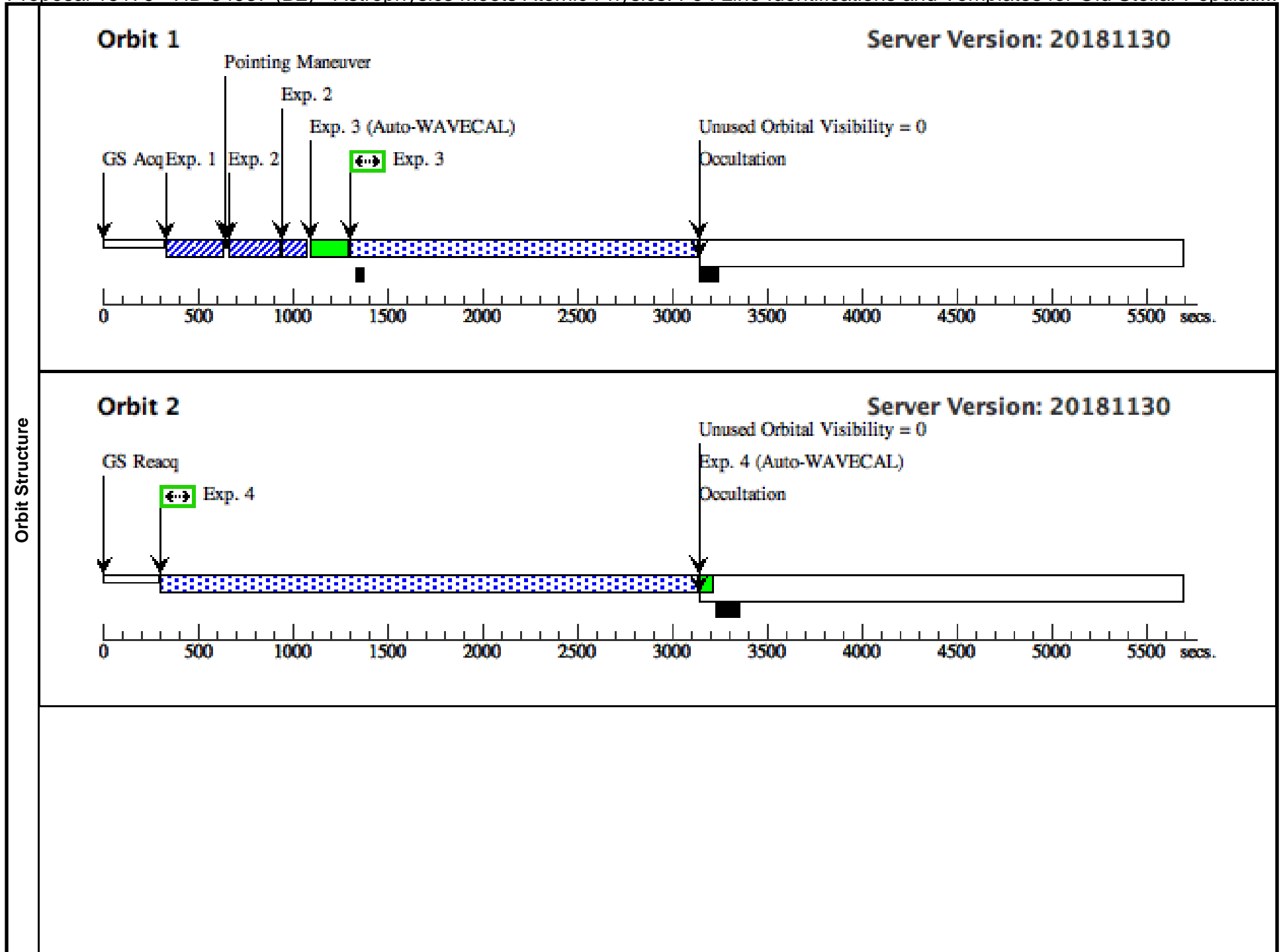

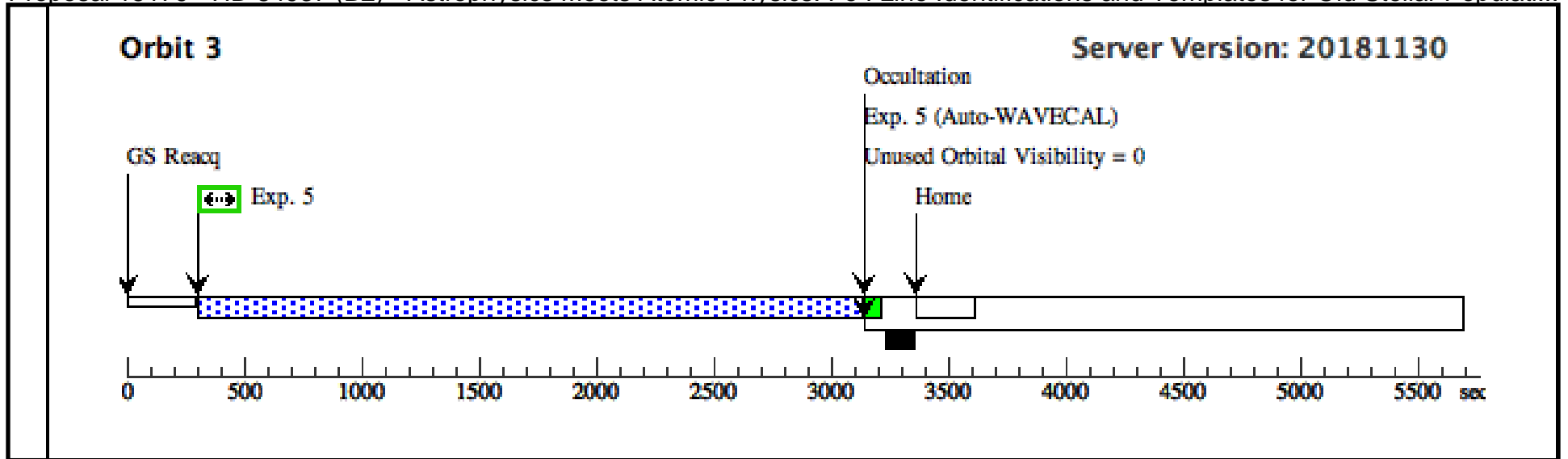

Proposal 15179 - HD 84937 (B3) - Astrophysics Meets Atomic Physics: Fe I Line Identifications and Templates for Old Stellar Populati...

Tue Dec 11 01:01:17 GMT 2018

Visit	<b>Proposal 15179, HD 84937 (B3), implementation</b> <b>Diagnostic Status: No Diagnostics</b> Scientific Instruments: STIS/NUV-MAMA, STIS/CCD Special Requirements: (none)									
Fixed Targets	#	Name	Target Coordinates	Targ. Coord. Corrections	Fluxes	Miscellaneous				
	(2)	HD-84937	RA: 09 48 56.0980 (147.2337417d) Dec: +13 44 39.32 (13.74426d) Equinox: J2000	Proper Motion RA: +373.05 mas/yr Proper Motion Dec: -774.38 mas/yr Parallax: 0.01374" Epoch of Position: 2000 Radial Velocity: -15 km/sec	V=8.32+/-1	Reference Frame: ICRS				
	<i>Comments: T<sub>eff</sub> = 6300, log g = 4.0, [Fe/H] = -2.25; very metal-poor turnoff star</i> Category=STAR Description=[F3-F9]									
Exposures	#	Label (ETC Run)	Target	Config,Mode,Aperture	Spectral Els.	Opt. Params.	Special Reqs.	Groups	Exp. Time (Total)/[Actual Dur.]	Orbit
	1	(STIS.ta.100 6207)	(2) HD-84937	STIS/CCD, ACQ, F25ND3	MIRROR				1 Secs (1 Secs) [==>]	[1]
	<i>Comments: Castelli-Kurucz Models F2V 7000 4.0; Renormalized to vegamag = 8.32 in filter Johnson/V</i> Time to Saturation (for a single exposure) = 24.11 seconds; 11,507 e- in 1.0 s (Note: assumed spectral type differs from SIMBAD F8V owing to metal deficiency of star.)									
	2	(STIS.sp.10 06205)	(2) HD-84937	STIS/CCD, ACQ/PEAK, 0.2X0.09	G430L 4300 A				0.1 Secs (0.1 Secs) [==>]	[1]
	<i>Comments: Castelli-Kurucz Models F2V 7000 4.0; Renormalized to vegamag = 8.32 in filter Johnson/V</i> Time to Saturation (for a single exposure) = 20.59 seconds; 267,396 e- in 0.1s (Note: assumed spectral type differs from SIMBAD F8V owing to metal deficiency of star.)									
	3	(STIS.sp.91 9947)	(2) HD-84937	STIS/NUV-MAMA, ACCUM, 0.2X0.09	E230H 1763 A				1813 Secs (1813 Secs) [==>]	[1]
	4	(STIS.sp.91 9947)	(2) HD-84937	STIS/NUV-MAMA, ACCUM, 0.2X0.09	E230H 1763 A				2817 Secs (2817 Secs) [==>]	[2]
	5	(STIS.sp.91 9947)	(2) HD-84937	STIS/NUV-MAMA, ACCUM, 0.2X0.09	E230H 1763 A				2817 Secs (2817 Secs) [==>]	[3]

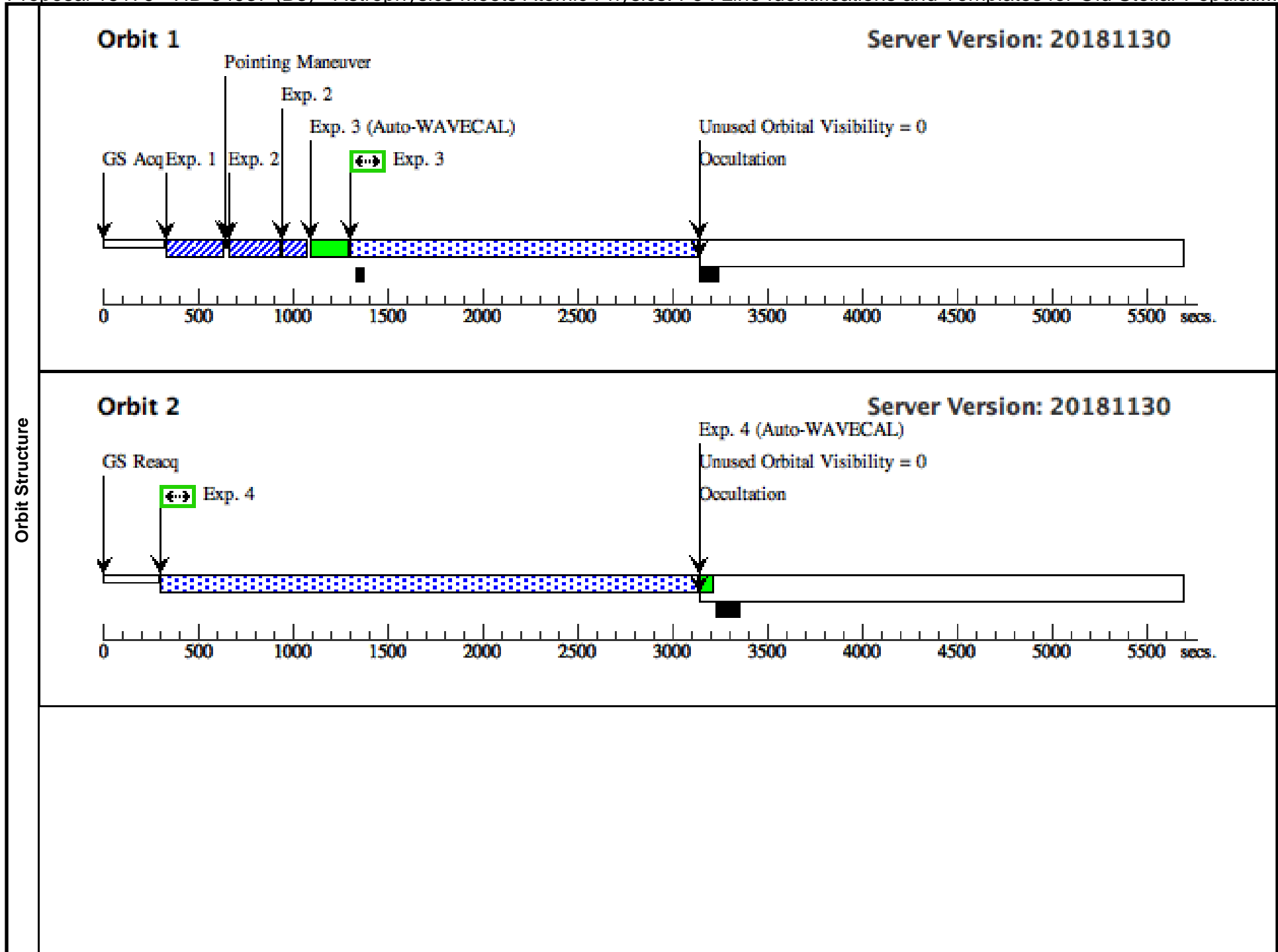

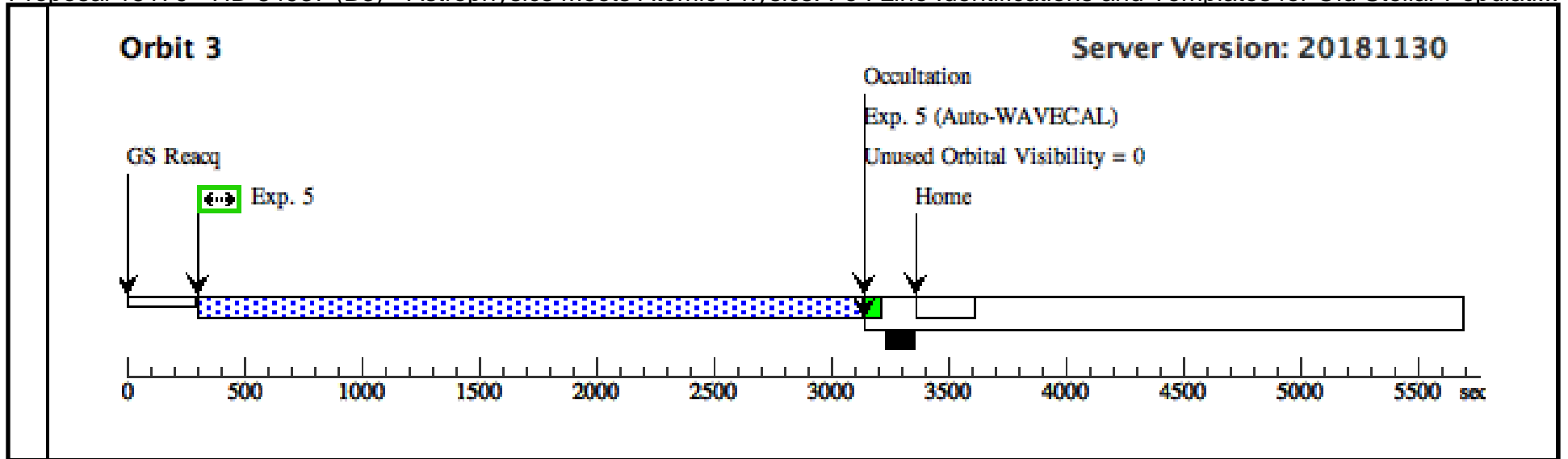

Proposal 15179 - HD 84937 (B4) - Astrophysics Meets Atomic Physics: Fe I Line Identifications and Templates for Old Stellar Populati...

Tue Dec 11 01:01:17 GMT 2018

Visit	<b>Proposal 15179, HD 84937 (B4), implementation</b> <b>Diagnostic Status: No Diagnostics</b> Scientific Instruments: STIS/NUV-MAMA, STIS/CCD Special Requirements: (none)										
	Fixed Targets	#	Name	Target Coordinates	Targ. Coord. Corrections	Fluxes	Miscellaneous				
		(2)	HD-84937	RA: 09 48 56.0980 (147.2337417d) Dec: +13 44 39.32 (13.74426d) Equinox: J2000	Proper Motion RA: +373.05 mas/yr Proper Motion Dec: -774.38 mas/yr Parallax: 0.01374" Epoch of Position: 2000 Radial Velocity: -15 km/sec	V=8.32+/-1	Reference Frame: ICRS				
	<i>Comments: T<sub>eff</sub> = 6300, log g = 4.0, [Fe/H] = -2.25; very metal-poor turnoff star</i> Category=STAR Description=[F3-F9]										
Exposures	#	Label (ETC Run)	Target	Config,Mode,Aperture	Spectral Els.	Opt. Params.	Special Reqs.	Groups	Exp. Time (Total)/[Actual Dur.]	Orbit	
	1	(STIS.ta.100 6207)	(2) HD-84937	STIS/CCD, ACQ, F25ND3	MIRROR				1 Secs (1 Secs)		
									[==>]	[1]	
		<i>Comments: Castelli-Kurucz Models F2V 7000 4.0; Renormalized to vegamag = 8.32 in filter Johnson/V</i> Time to Saturation (for a single exposure) = 24.11 seconds; 11,507 e- in 1.0 s (Note: assumed spectral type differs from SIMBAD F8V owing to metal deficiency of star.)									
	2	(STIS.sp.10 06205)	(2) HD-84937	STIS/CCD, ACQ/PEAK, 0.2X0.09	G430L 4300 A				0.1 Secs (0.1 Secs)		
									[==>]	[1]	
		<i>Comments: Castelli-Kurucz Models F2V 7000 4.0; Renormalized to vegamag = 8.32 in filter Johnson/V</i> Time to Saturation (for a single exposure) = 20.59 seconds; 267,396 e- in 0.1s (Note: assumed spectral type differs from SIMBAD F8V owing to metal deficiency of star.)									
3	(STIS.sp.91 9947)	(2) HD-84937	STIS/NUV-MAMA, ACCUM, 0.2X0.09	E230H 1763 A				1813 Secs (1813 Secs)			
								[==>]	[1]		
4	(STIS.sp.91 9947)	(2) HD-84937	STIS/NUV-MAMA, ACCUM, 0.2X0.09	E230H 1763 A				2817 Secs (2817 Secs)			
								[==>]	[2]		
5	(STIS.sp.91 9947)	(2) HD-84937	STIS/NUV-MAMA, ACCUM, 0.2X0.09	E230H 1763 A				2817 Secs (2817 Secs)			
								[==>]	[3]		

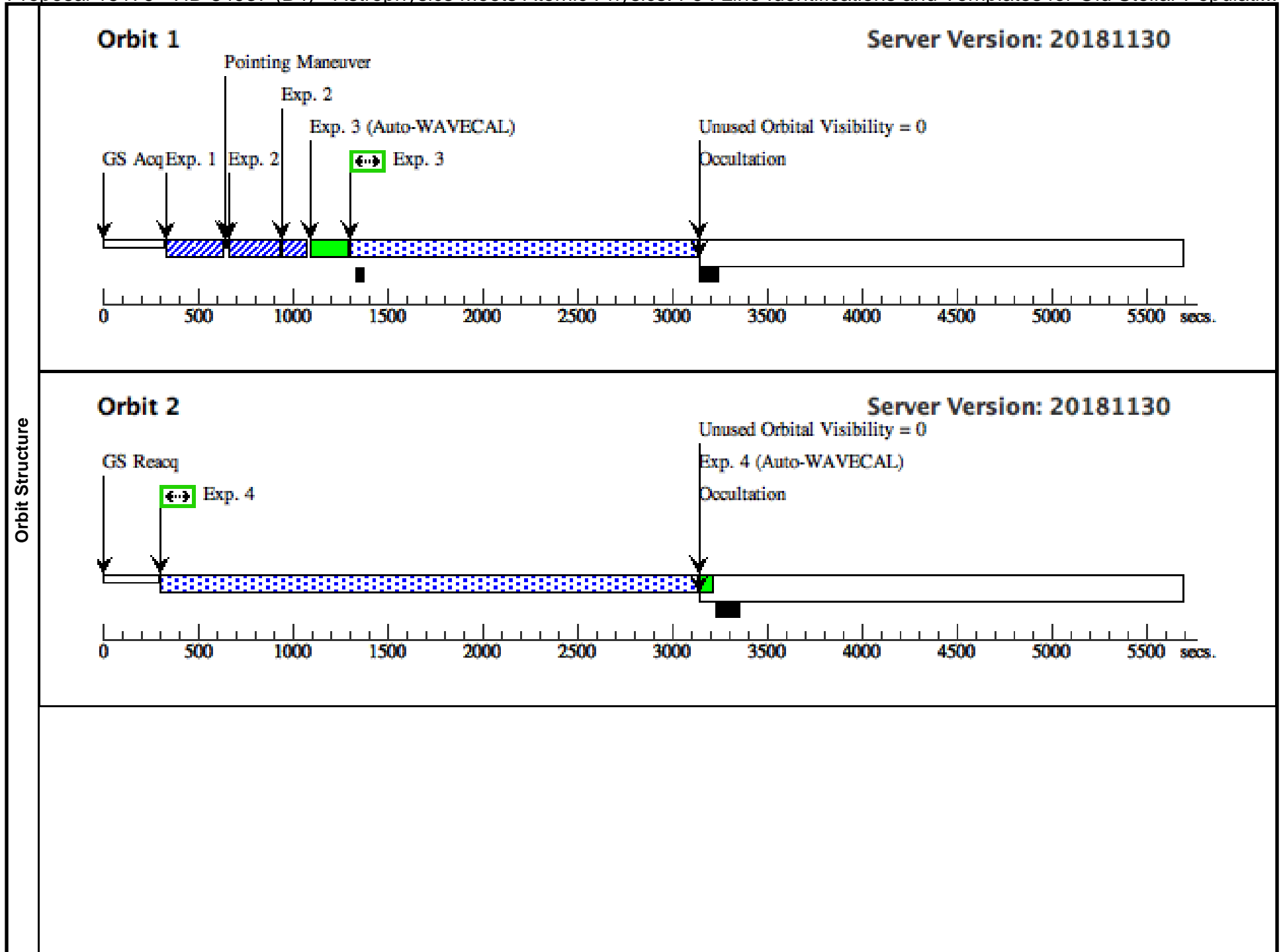

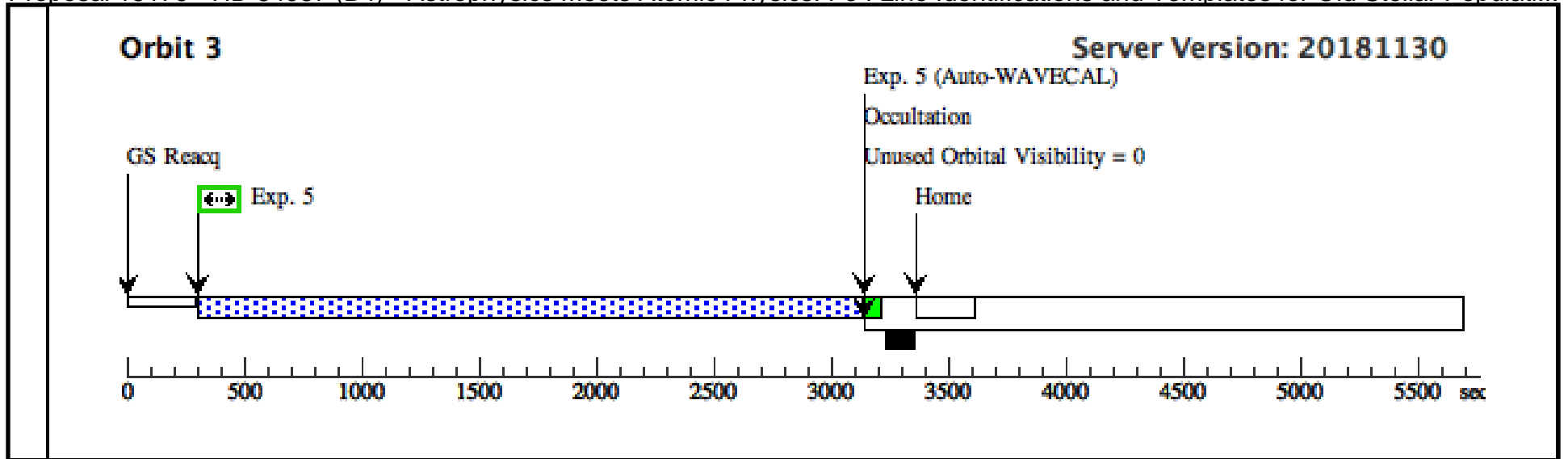

Proposal 15179 - HD 84937 (B5) - Astrophysics Meets Atomic Physics: Fe I Line Identifications and Templates for Old Stellar Populati...

Tue Dec 11 01:01:17 GMT 2018

Visit	<b>Proposal 15179, HD 84937 (B5), implementation</b> <b>Diagnostic Status: No Diagnostics</b> Scientific Instruments: STIS/NUV-MAMA, STIS/CCD Special Requirements: (none)										
	Fixed Targets	#	Name	Target Coordinates	Targ. Coord. Corrections	Fluxes	Miscellaneous				
		(2)	HD-84937	RA: 09 48 56.0980 (147.2337417d) Dec: +13 44 39.32 (13.74426d) Equinox: J2000	Proper Motion RA: +373.05 mas/yr Proper Motion Dec: -774.38 mas/yr Parallax: 0.01374" Epoch of Position: 2000 Radial Velocity: -15 km/sec	V=8.32+/-1	Reference Frame: ICRS				
	<i>Comments: T<sub>eff</sub> = 6300, log g = 4.0, [Fe/H] = -2.25; very metal-poor turnoff star</i> Category=STAR Description=[F3-F9]										
Exposures	#	Label (ETC Run)	Target	Config,Mode,Aperture	Spectral Els.	Opt. Params.	Special Reqs.	Groups	Exp. Time (Total)/[Actual Dur.]	Orbit	
	1	(STIS.ta.100 6207)	(2) HD-84937	STIS/CCD, ACQ, F25ND3	MIRROR				1 Secs (1 Secs)		
		<i>Comments: Castelli-Kurucz Models F2V 7000 4.0; Renormalized to vegamag = 8.32 in filter Johnson/V</i> Time to Saturation (for a single exposure) = 24.11 seconds; 11,507 e- in 1.0 s (Note: assumed spectral type differs from SIMBAD F8V owing to metal deficiency of star.)									
	2	(STIS.sp.10 06205)	(2) HD-84937	STIS/CCD, ACQ/PEAK, 0.2X0.09	G430L 4300 A				0.1 Secs (0.1 Secs)		
		<i>Comments: Castelli-Kurucz Models F2V 7000 4.0; Renormalized to vegamag = 8.32 in filter Johnson/V</i> Time to Saturation (for a single exposure) = 20.59 seconds; 267,396 e- in 0.1s (Note: assumed spectral type differs from SIMBAD F8V owing to metal deficiency of star.)									
	3	(STIS.sp.91 9947)	(2) HD-84937	STIS/NUV-MAMA, ACCUM, 0.2X0.09	E230H 1763 A				1813 Secs (1813 Secs)		
	4	(STIS.sp.91 9947)	(2) HD-84937	STIS/NUV-MAMA, ACCUM, 0.2X0.09	E230H 1763 A				2817 Secs (2817 Secs)		
5	(STIS.sp.91 9947)	(2) HD-84937	STIS/NUV-MAMA, ACCUM, 0.2X0.09	E230H 1763 A				2817 Secs (2817 Secs)			

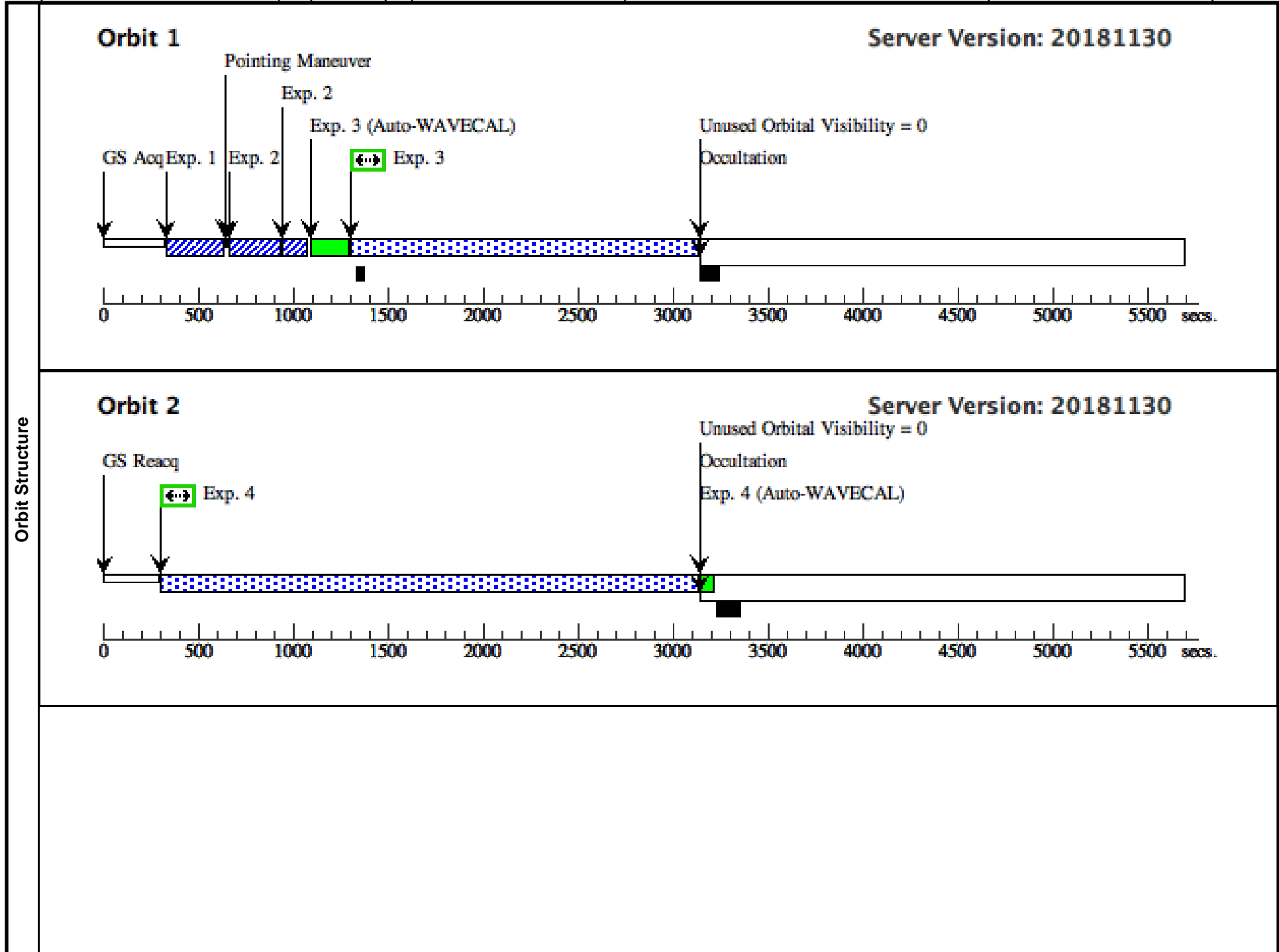

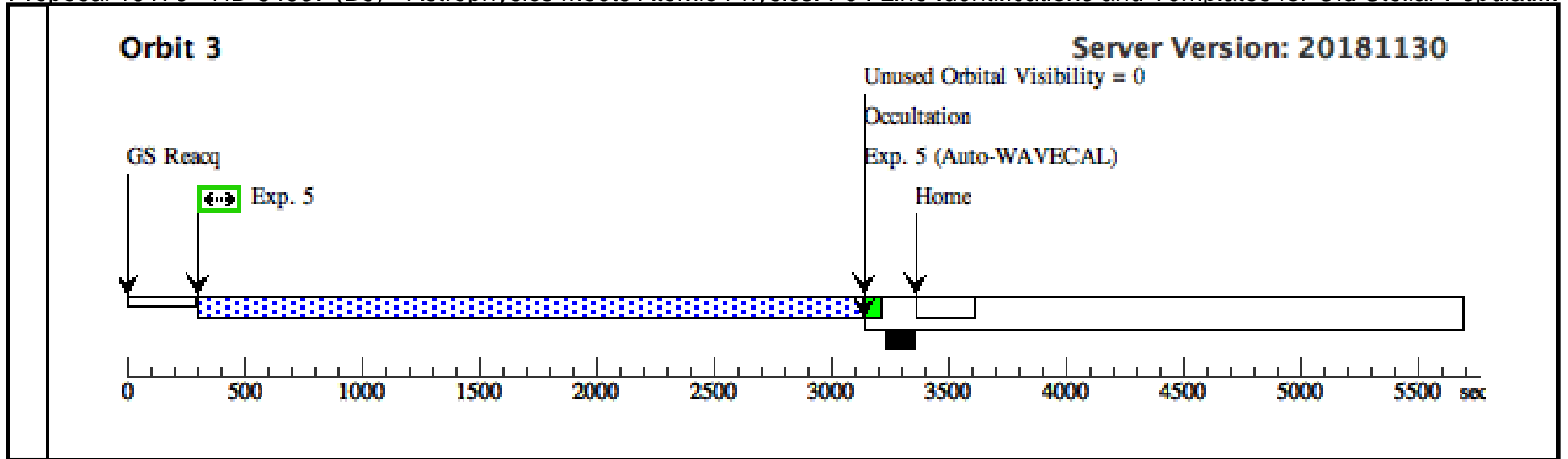

Proposal 15179 - HD 86986 (C0) - Astrophysics Meets Atomic Physics: Fe I Line Identifications and Templates for Old Stellar Populati...

Tue Dec 11 01:01:17 GMT 2018

<b>Visit</b>	<b>Proposal 15179, HD 86986 (C0), completed</b> <b>Diagnostic Status: Warning</b> Scientific Instruments: STIS/NUV-MAMA, STIS/CCD Special Requirements: (none)									
	(HD 86986 (C0)) Warning (Orbit Planner): ORBITAL VISIBILITY OVERRUN (HD 86986 (C0)) Warning (Orbit Planner): ORBITAL VISIBILITY OVERRUN (HD 86986 (C0)) Warning (Orbit Planner): ORBITAL VISIBILITY OVERRUN									
<b>Fixed Targets</b>	<b>#</b>	<b>Name</b>	<b>Target Coordinates</b>	<b>Targ. Coord. Corrections</b>		<b>Fluxes</b>	<b>Miscellaneous</b>			
	(3)	HD-86986	RA: 10 02 29.5659 (150.6231912d) Dec: +14 33 25.19 (14.55700d) Equinox: J2000	Proper Motion RA: 143.47 mas/yr Proper Motion Dec: -208.76 mas/yr Parallax: 0.00339" Epoch of Position: 2000 Radial Velocity: +9.5 km/sec	V=7.99+/-1	Reference Frame: ICRS				
Comments: $T_{\text{eff}} = 8000$ , $\log g = 3.2$ , $[Fe/H] = -1.60$ ; metal-poor blue horizontal branch star Category=STAR Description=[A0-A3 V-IV]										
<b>Exposures</b>	<b>#</b>	<b>Label (ETC Run)</b>	<b>Target</b>	<b>Config,Mode,Aperture</b>	<b>Spectral Els.</b>	<b>Opt. Params.</b>	<b>Special Reqs.</b>	<b>Groups</b>	<b>Exp. Time (Total)/[Actual Dur.]</b>	<b>Orbit</b>
	1	(STIS.ta.100 6168)	(3) HD-86986	STIS/CCD, ACQ, F25ND3	MIRROR				1 Secs (1 Secs) [==>]	[1]
	Comments: Castelli-Kurucz Models A1V 9250 4.0; Renormalized to vegamag = 7.99 in filter Johnson/V Time to Saturation (for a single exposure) = 18.29 seconds; 14,445 e- in 1.0s									
	2	(STIS.sp.10 06181)	(3) HD-86986	STIS/CCD, ACQ/PEAK, 0.2X0.09	G430L 4300 A				0.1 Secs (0.1 Secs) [==>]	[1]
	Comments: Castelli-Kurucz Models A1V 9250 4.0; Renormalized to vegamag = 7.99 in filter Johnson/V Time to Saturation (for a single exposure) = 11.72 seconds; 442,002 e- in 0.1s									
	3	(STIS.sp.91 6302)	(3) HD-86986	STIS/NUV-MAMA, ACCUM, 0.2X0.09	E230H 1763 A				1873 Secs (1873 Secs) [==>]	[1]
4	(STIS.sp.91 6302)	(3) HD-86986	STIS/NUV-MAMA, ACCUM, 0.2X0.09	E230H 1763 A				2957 Secs (2957 Secs) [==>]	[2]	
5	(STIS.sp.91 6302)	(3) HD-86986	STIS/NUV-MAMA, ACCUM, 0.2X0.09	E230H 1763 A				2957 Secs (2957 Secs) [==>]	[3]	

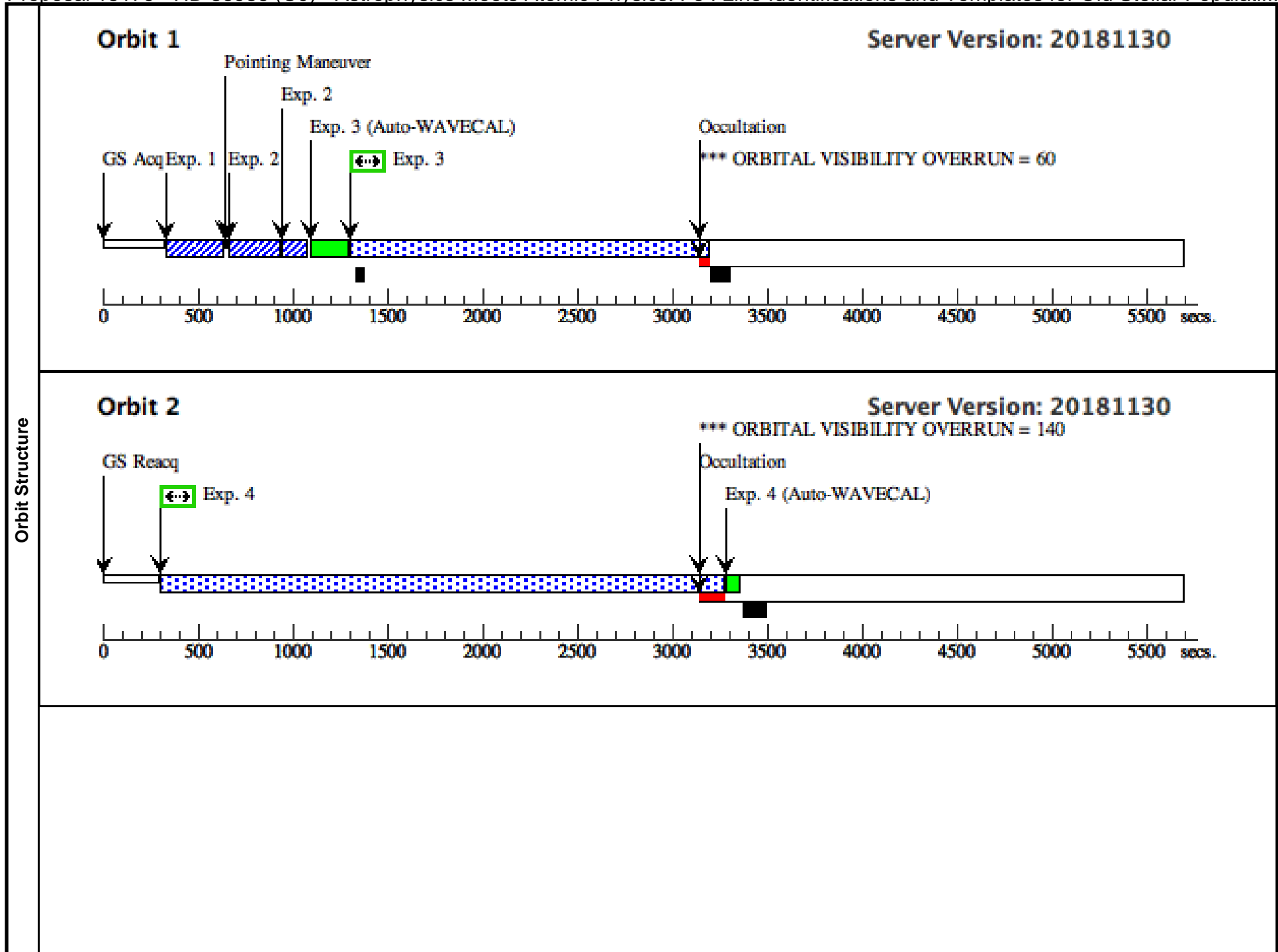

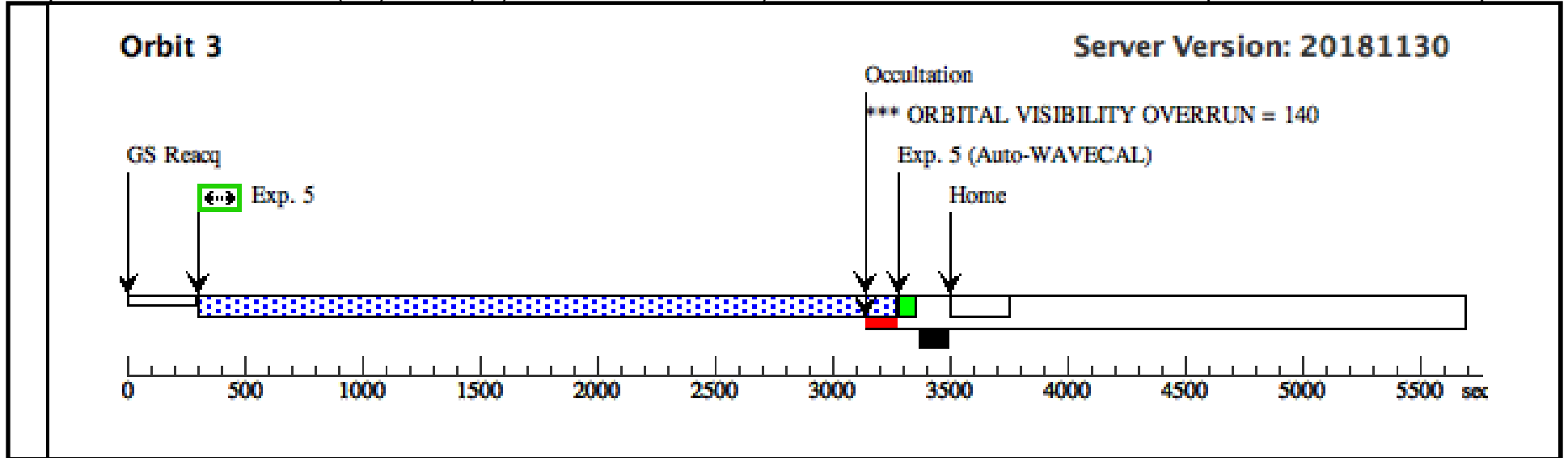

Proposal 15179 - HD 86986 (C1) - Astrophysics Meets Atomic Physics: Fe I Line Identifications and Templates for Old Stellar Populati...

Tue Dec 11 01:01:17 GMT 2018

<b>Visit</b>	<b>Proposal 15179, HD 86986 (C1), completed</b> <b>Diagnostic Status: Warning</b> Scientific Instruments: STIS/NUV-MAMA, STIS/CCD Special Requirements: (none)											
	(HD 86986 (C1)) Warning (Orbit Planner): ORBITAL VISIBILITY OVERRUN (HD 86986 (C1)) Warning (Orbit Planner): ORBITAL VISIBILITY OVERRUN (HD 86986 (C1)) Warning (Orbit Planner): ORBITAL VISIBILITY OVERRUN											
<b>Fixed Targets</b>	<b>#</b>	<b>Name</b>	<b>Target Coordinates</b>	<b>Targ. Coord. Corrections</b>		<b>Fluxes</b>	<b>Miscellaneous</b>					
	(3)	HD-86986	RA: 10 02 29.5659 (150.6231912d) Dec: +14 33 25.19 (14.55700d) Equinox: J2000	Proper Motion RA: 143.47 mas/yr Proper Motion Dec: -208.76 mas/yr Parallax: 0.00339" Epoch of Position: 2000 Radial Velocity: +9.5 km/sec		V=7.99+/-1	Reference Frame: ICRS					
Comments: $T_{\text{eff}} = 8000$ , $\log g = 3.2$ , $[Fe/H] = -1.60$ ; metal-poor blue horizontal branch star Category=STAR Description=[A0-A3 V-IV]												
<b>Exposures</b>	<b>#</b>	<b>Label (ETC Run)</b>	<b>Target</b>	<b>Config,Mode,Aperture</b>	<b>Spectral Els.</b>	<b>Opt. Params.</b>	<b>Special Reqs.</b>	<b>Groups</b>	<b>Exp. Time (Total)/[Actual Dur.]</b>		<b>Orbit</b>	
	1	(STIS.ta.100 6168)	(3) HD-86986	STIS/CCD, ACQ, F25ND3	MIRROR				1 Secs (1 Secs)			
										[==>]	[1]	
	Comments: Castelli-Kurucz Models A1V 9250 4.0; Renormalized to vegamag = 7.99 in filter Johnson/V Time to Saturation (for a single exposure) = 18.29 seconds; 14,445 e- in 1.0s											
	2	(STIS.sp.10 06181)	(3) HD-86986	STIS/CCD, ACQ/PEAK, 0.2X0.09	G430L 4300 A					0.1 Secs (0.1 Secs)		
										[==>]	[1]	
Comments: Castelli-Kurucz Models A1V 9250 4.0; Renormalized to vegamag = 7.99 in filter Johnson/V Time to Saturation (for a single exposure) = 11.72 seconds; 442,002 e- in 0.1s												
3	(STIS.sp.91 6302)	(3) HD-86986	STIS/NUV-MAMA, ACCUM, 0.2X0.09	E230H 1763 A					1873 Secs (1873 Secs)			
									[==>]	[1]		
4	(STIS.sp.91 6302)	(3) HD-86986	STIS/NUV-MAMA, ACCUM, 0.2X0.09	E230H 1763 A					2957 Secs (2957 Secs)			
									[==>]	[2]		
5	(STIS.sp.91 6302)	(3) HD-86986	STIS/NUV-MAMA, ACCUM, 0.2X0.09	E230H 1763 A					2957 Secs (2957 Secs)			
									[==>]	[3]		

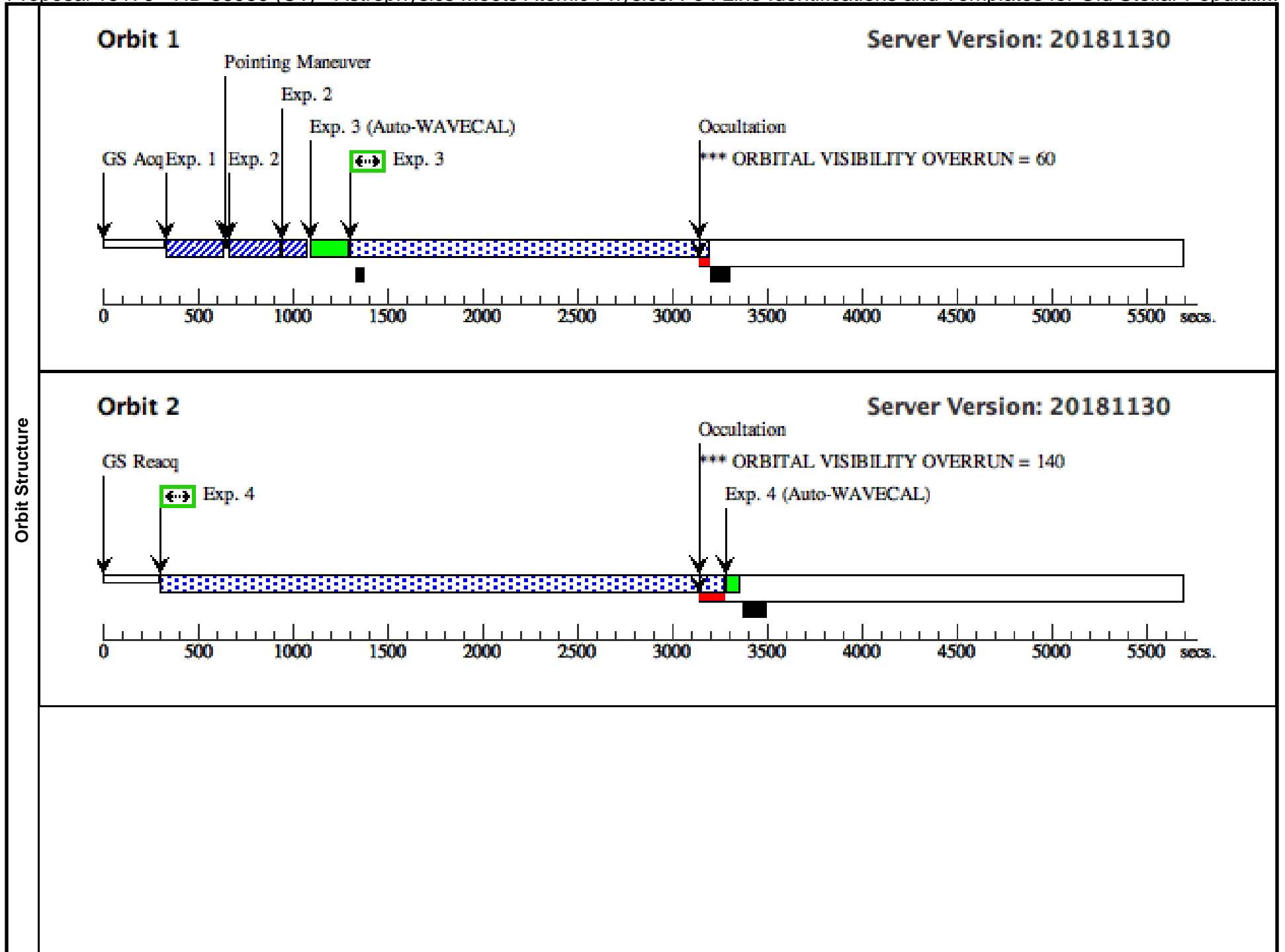

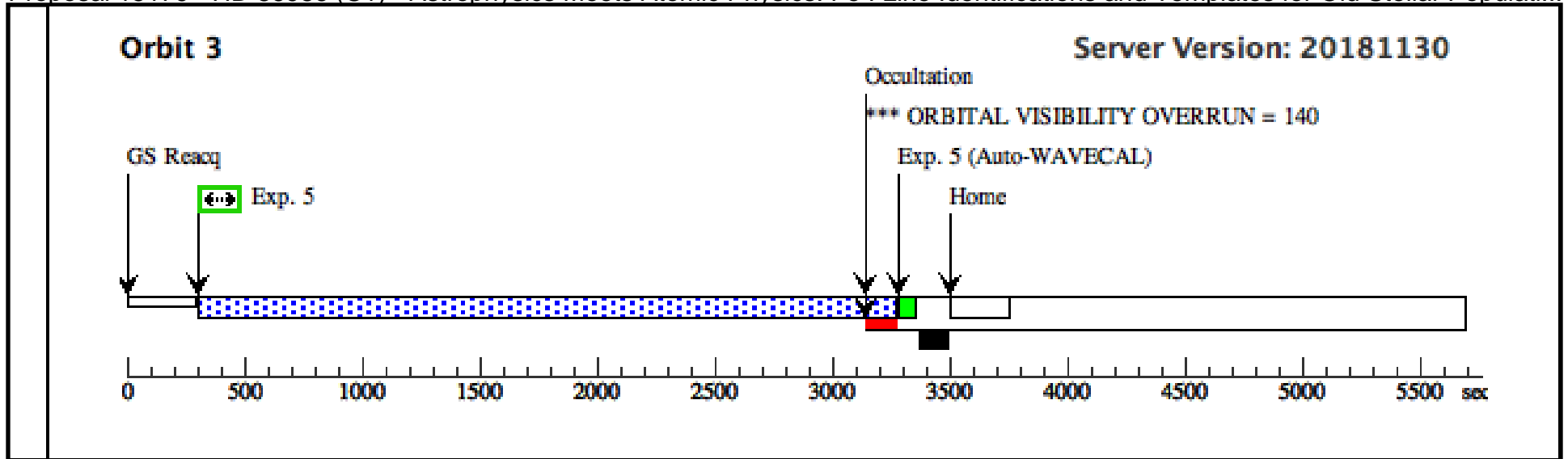

Proposal 15179 - HD 86986 (C2) - Astrophysics Meets Atomic Physics: Fe I Line Identifications and Templates for Old Stellar Populati...

Tue Dec 11 01:01:17 GMT 2018

<b>Visit</b>	<b>Proposal 15179, HD 86986 (C2), completed</b> <b>Diagnostic Status: Warning</b> Scientific Instruments: STIS/NUV-MAMA, STIS/CCD Special Requirements: (none)									
	(HD 86986 (C2)) Warning (Orbit Planner): ORBITAL VISIBILITY OVERRUN (HD 86986 (C2)) Warning (Orbit Planner): ORBITAL VISIBILITY OVERRUN (HD 86986 (C2)) Warning (Orbit Planner): ORBITAL VISIBILITY OVERRUN									
<b>Fixed Targets</b>	<b>#</b>	<b>Name</b>	<b>Target Coordinates</b>	<b>Targ. Coord. Corrections</b>		<b>Fluxes</b>	<b>Miscellaneous</b>			
	(3)	HD-86986	RA: 10 02 29.5659 (150.6231912d) Dec: +14 33 25.19 (14.55700d) Equinox: J2000	Proper Motion RA: 143.47 mas/yr Proper Motion Dec: -208.76 mas/yr Parallax: 0.00339" Epoch of Position: 2000 Radial Velocity: +9.5 km/sec		V=7.99+/-1	Reference Frame: ICRS			
Comments: $T_{eff} = 8000$ , $\log g = 3.2$ , $[Fe/H] = -1.60$ ; metal-poor blue horizontal branch star Category=STAR Description=[A0-A3 V-IV]										
<b>Exposures</b>	<b>#</b>	<b>Label (ETC Run)</b>	<b>Target</b>	<b>Config,Mode,Aperture</b>	<b>Spectral Els.</b>	<b>Opt. Params.</b>	<b>Special Reqs.</b>	<b>Groups</b>	<b>Exp. Time (Total)/[Actual Dur.]</b>	<b>Orbit</b>
	1	(STIS.ta.100 6168)	(3) HD-86986	STIS/CCD, ACQ, F25ND3	MIRROR				1 Secs (1 Secs) [==>]	[1]
	Comments: Castelli-Kurucz Models A1V 9250 4.0; Renormalized to vegamag = 7.99 in filter Johnson/V Time to Saturation (for a single exposure) = 18.29 seconds; 14,445 e- in 1.0s									
	2	(STIS.sp.10 06181)	(3) HD-86986	STIS/CCD, ACQ/PEAK, 0.2X0.09	G430L 4300 A				0.1 Secs (0.1 Secs) [==>]	[1]
	Comments: Castelli-Kurucz Models A1V 9250 4.0; Renormalized to vegamag = 7.99 in filter Johnson/V Time to Saturation (for a single exposure) = 11.72 seconds; 442,002 e- in 0.1s									
	3	(STIS.sp.91 6302)	(3) HD-86986	STIS/NUV-MAMA, ACCUM, 0.2X0.09	E230H 1763 A				1873 Secs (1873 Secs) [==>]	[1]
4	(STIS.sp.91 6302)	(3) HD-86986	STIS/NUV-MAMA, ACCUM, 0.2X0.09	E230H 1763 A				2957 Secs (2957 Secs) [==>]	[2]	
5	(STIS.sp.91 6302)	(3) HD-86986	STIS/NUV-MAMA, ACCUM, 0.2X0.09	E230H 1763 A				2957 Secs (2957 Secs) [==>]	[3]	

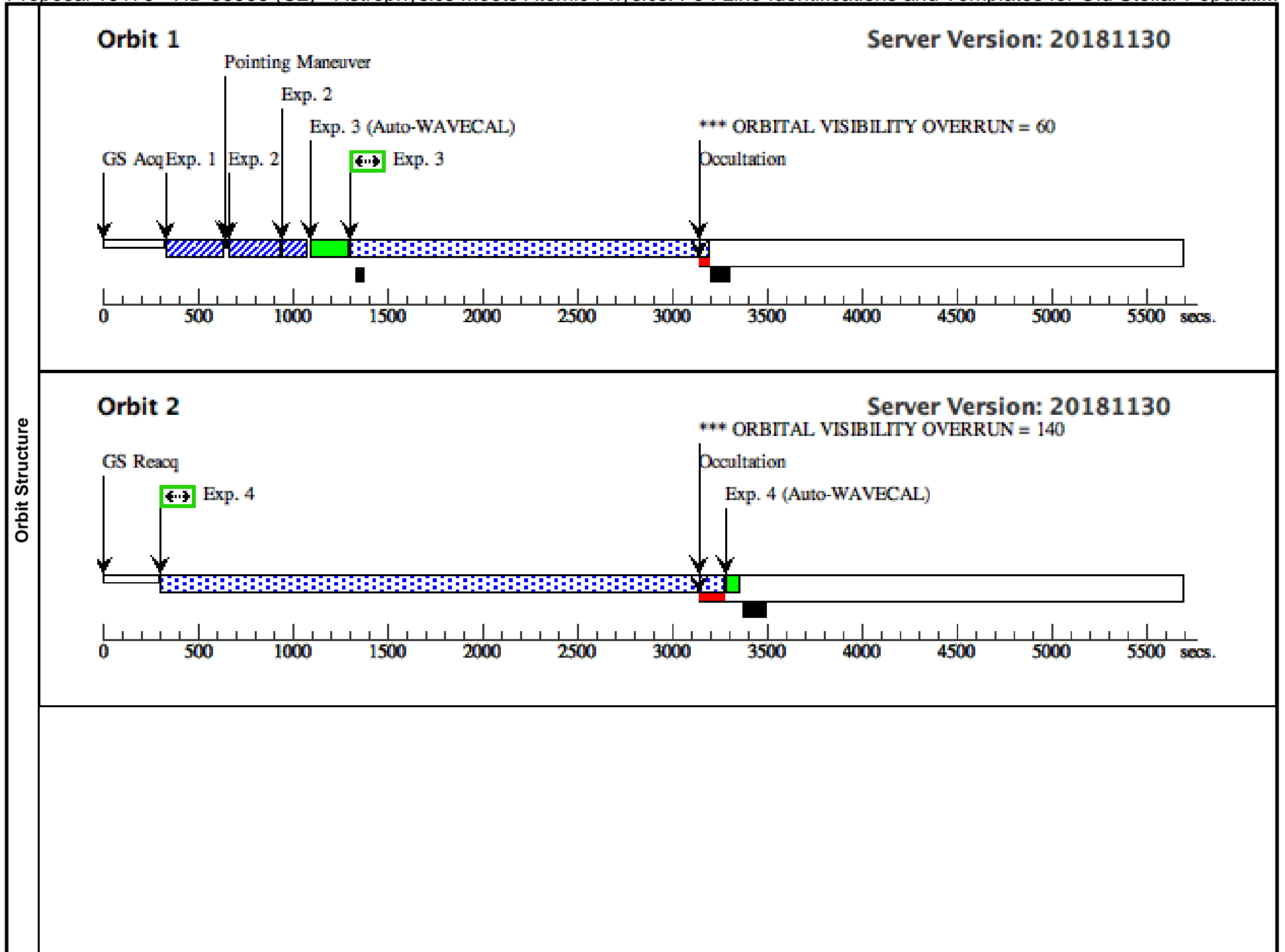

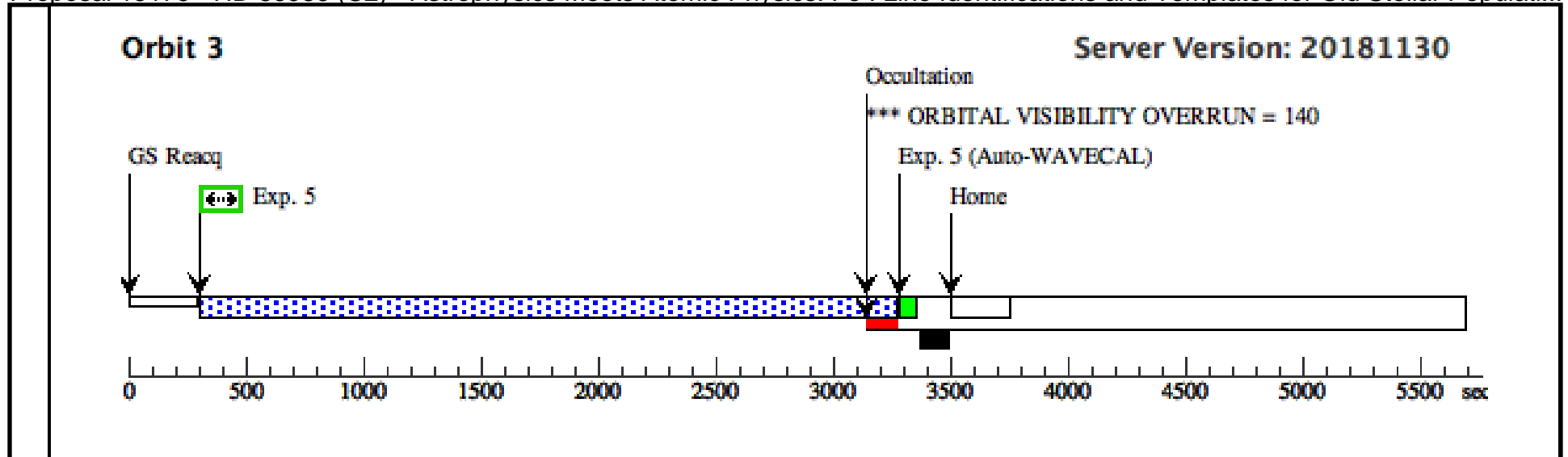

Proposal 15179 - HD 86986 (C3) - Astrophysics Meets Atomic Physics: Fe I Line Identifications and Templates for Old Stellar Populati...

Tue Dec 11 01:01:18 GMT 2018

Visit	<b>Proposal 15179, HD 86986 (C3), implementation</b> <b>Diagnostic Status: No Diagnostics</b> Scientific Instruments: STIS/NUV-MAMA, STIS/CCD Special Requirements: (none)									
	Fixed Targets	#	Name	Target Coordinates	Targ. Coord. Corrections	Fluxes	Miscellaneous			
		(3)	HD-86986	RA: 10 02 29.5659 (150.6231912d) Dec: +14 33 25.19 (14.55700d) Equinox: J2000	Proper Motion RA: 143.47 mas/yr Proper Motion Dec: -208.76 mas/yr Parallax: 0.00339" Epoch of Position: 2000 Radial Velocity: +9.5 km/sec	V=7.99+/-1	Reference Frame: ICRS			
	<i>Comments: T<sub>eff</sub> = 8000, log g = 3.2, [Fe/H] = -1.60; metal-poor blue horizontal branch star</i> Category=STAR Description=[A0-A3 V-IV]									
Exposures	#	Label (ETC Run)	Target	Config,Mode,Aperture	Spectral Els.	Opt. Params.	Special Reqs.	Groups	Exp. Time (Total)/[Actual Dur.]	Orbit
	1	(STIS.ta.100 6168)	(3) HD-86986	STIS/CCD, ACQ, F25ND3	MIRROR				1 Secs (1 Secs)	
									[==>]	[1]
	<i>Comments: Castelli-Kurucz Models AIV 9250 4.0; Renormalized to vegamag = 7.99 in filter Johnson/V</i> Time to Saturation (for a single exposure) = 18.29 seconds; 14,445 e- in 1.0s									
	2	(STIS.sp.10 06181)	(3) HD-86986	STIS/CCD, ACQ/PEAK, 0.2X0.09	G430L 4300 A				0.1 Secs (0.1 Secs)	
									[==>]	[1]
	<i>Comments: Castelli-Kurucz Models AIV 9250 4.0; Renormalized to vegamag = 7.99 in filter Johnson/V</i> Time to Saturation (for a single exposure) = 11.72 seconds; 442,002 e- in 0.1s									
3	(STIS.sp.91 6302)	(3) HD-86986	STIS/NUV-MAMA, ACCUM, 0.2X0.09	E230H 1763 A				1813 Secs (1813 Secs)		
								[==>]	[1]	
4	(STIS.sp.91 6302)	(3) HD-86986	STIS/NUV-MAMA, ACCUM, 0.2X0.09	E230H 1763 A				2817 Secs (2817 Secs)		
								[==>]	[2]	
5	(STIS.sp.91 6302)	(3) HD-86986	STIS/NUV-MAMA, ACCUM, 0.2X0.09	E230H 1763 A				2817 Secs (2817 Secs)		
								[==>]	[3]	

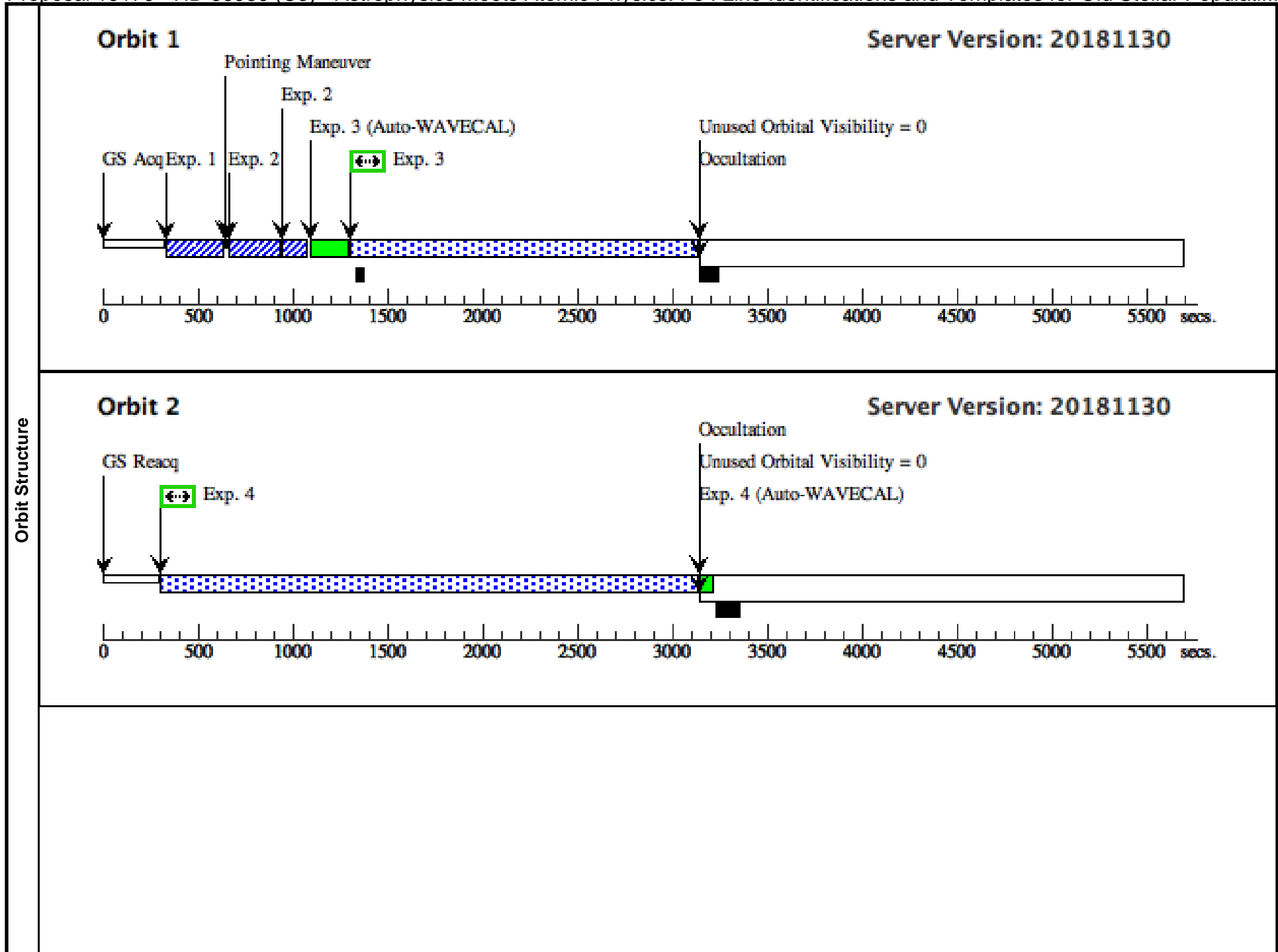

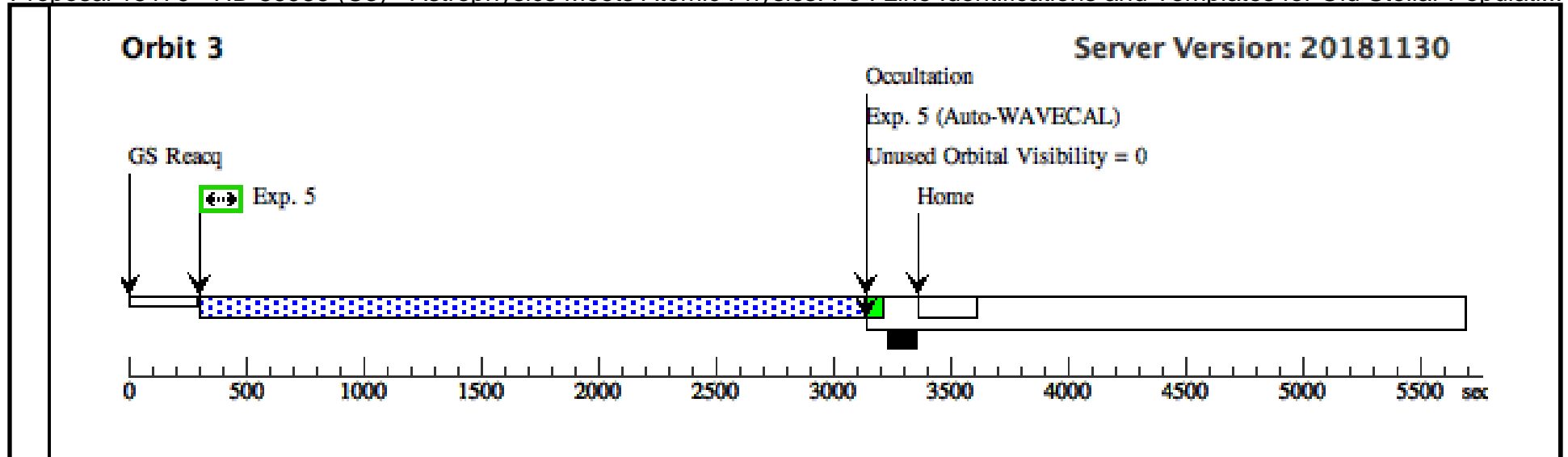

Proposal 15179 - HD 86986 (C4) - Astrophysics Meets Atomic Physics: Fe I Line Identifications and Templates for Old Stellar Populati...

Tue Dec 11 01:01:18 GMT 2018

Visit	<b>Proposal 15179, HD 86986 (C4), implementation</b> <b>Diagnostic Status: No Diagnostics</b> Scientific Instruments: STIS/NUV-MAMA, STIS/CCD Special Requirements: (none)									
Fixed Targets	#	Name	Target Coordinates	Targ. Coord. Corrections	Fluxes	Miscellaneous				
	(3)	HD-86986	RA: 10 02 29.5659 (150.6231912d) Dec: +14 33 25.19 (14.55700d) Equinox: J2000	Proper Motion RA: 143.47 mas/yr Proper Motion Dec: -208.76 mas/yr Parallax: 0.00339" Epoch of Position: 2000 Radial Velocity: +9.5 km/sec	V=7.99+/-1	Reference Frame: ICRS				
	<i>Comments: T<sub>eff</sub> = 8000, log g = 3.2, [Fe/H] = -1.60; metal-poor blue horizontal branch star</i> Category=STAR Description=[A0-A3 V-IV]									
Exposures	#	Label (ETC Run)	Target	Config,Mode,Aperture	Spectral Els.	Opt. Params.	Special Reqs.	Groups	Exp. Time (Total)/[Actual Dur.]	Orbit
	1	(STIS.ta.100 6168)	(3) HD-86986	STIS/CCD, ACQ, F25ND3	MIRROR				1 Secs (1 Secs) [==>]	[1]
	<i>Comments: Castelli-Kurucz Models AIV 9250 4.0; Renormalized to vegamag = 7.99 in filter Johnson/V</i> Time to Saturation (for a single exposure) = 18.29 seconds; 14,445 e- in 1.0s									
	2	(STIS.sp.10 06181)	(3) HD-86986	STIS/CCD, ACQ/PEAK, 0.2X0.09	G430L 4300 A				0.1 Secs (0.1 Secs) [==>]	[1]
	<i>Comments: Castelli-Kurucz Models AIV 9250 4.0; Renormalized to vegamag = 7.99 in filter Johnson/V</i> Time to Saturation (for a single exposure) = 11.72 seconds; 442,002 e- in 0.1s									
	3	(STIS.sp.91 6302)	(3) HD-86986	STIS/NUV-MAMA, ACCUM, 0.2X0.09	E230H 1763 A				1813 Secs (1813 Secs) [==>]	[1]
	4	(STIS.sp.91 6302)	(3) HD-86986	STIS/NUV-MAMA, ACCUM, 0.2X0.09	E230H 1763 A				2817 Secs (2817 Secs) [==>]	[2]
	5	(STIS.sp.91 6302)	(3) HD-86986	STIS/NUV-MAMA, ACCUM, 0.2X0.09	E230H 1763 A				2817 Secs (2817 Secs) [==>]	[3]

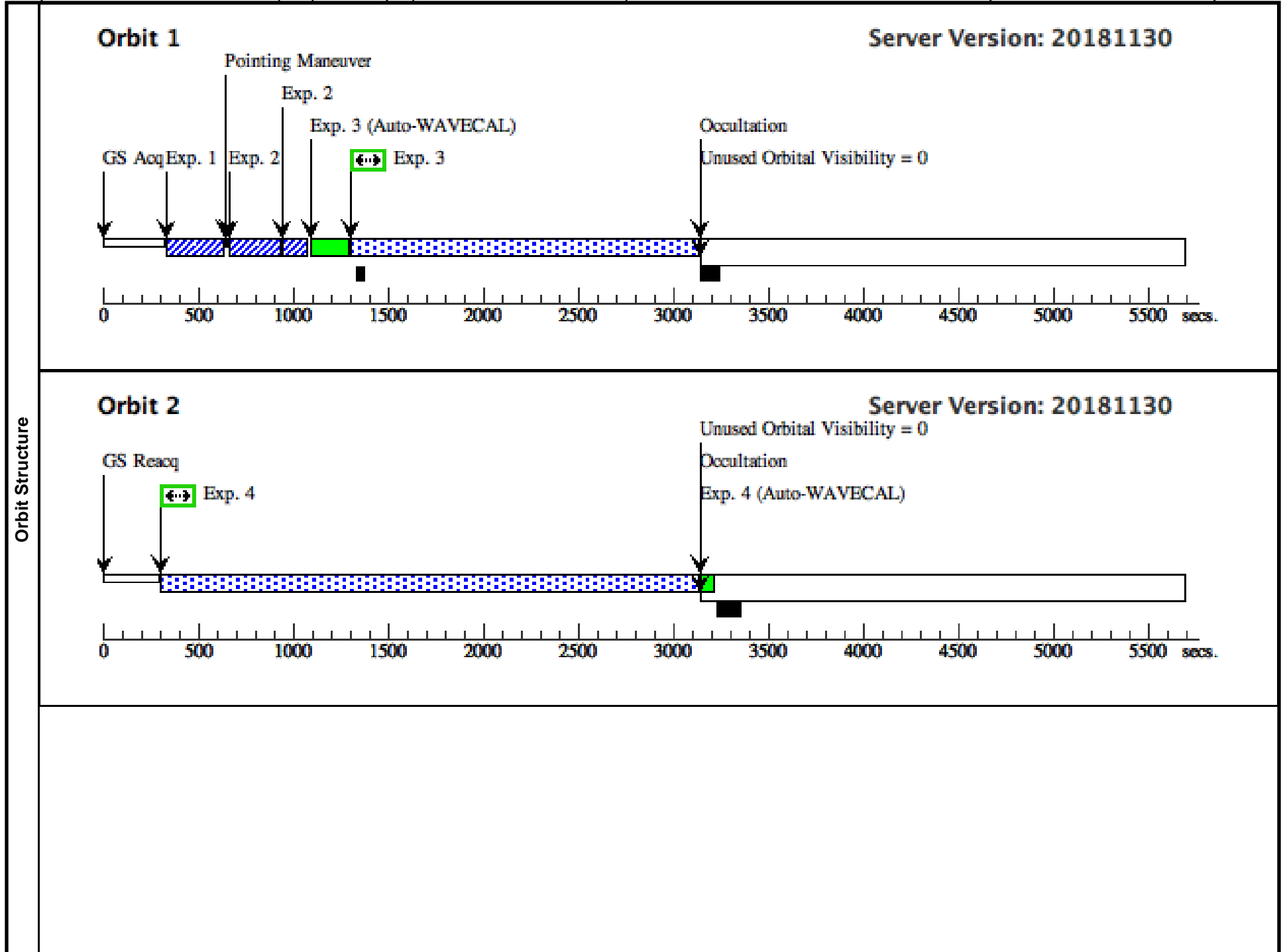

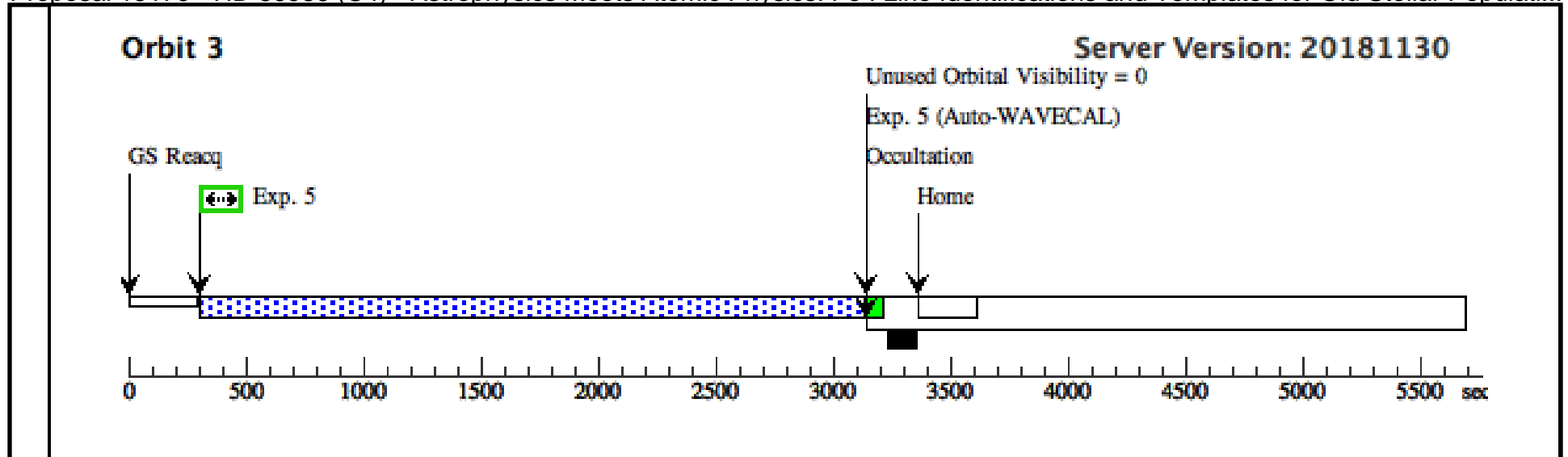

Proposal 15179 - HD 86986 (C5) - Astrophysics Meets Atomic Physics: Fe I Line Identifications and Templates for Old Stellar Populati...

Tue Dec 11 01:01:18 GMT 2018

Visit	<b>Proposal 15179, HD 86986 (C5), implementation</b> <b>Diagnostic Status: No Diagnostics</b> Scientific Instruments: STIS/NUV-MAMA, STIS/CCD Special Requirements: (none)									
	Fixed Targets	#	Name	Target Coordinates	Targ. Coord. Corrections	Fluxes	Miscellaneous			
		(3)	HD-86986	RA: 10 02 29.5659 (150.6231912d) Dec: +14 33 25.19 (14.55700d) Equinox: J2000	Proper Motion RA: 143.47 mas/yr Proper Motion Dec: -208.76 mas/yr Parallax: 0.00339" Epoch of Position: 2000 Radial Velocity: +9.5 km/sec	V=7.99+/-1	Reference Frame: ICRS			
	<i>Comments: T<sub>eff</sub> = 8000, log g = 3.2, [Fe/H] = -1.60; metal-poor blue horizontal branch star</i> Category=STAR Description=[A0-A3 V-IV]									
Exposures	#	Label (ETC Run)	Target	Config,Mode,Aperture	Spectral Els.	Opt. Params.	Special Reqs.	Groups	Exp. Time (Total)/[Actual Dur.]	Orbit
	1	(STIS.ta.100 6168)	(3) HD-86986	STIS/CCD, ACQ, F25ND3	MIRROR				1 Secs (1 Secs)	
									[==>]	[1]
	<i>Comments: Castelli-Kurucz Models AIV 9250 4.0; Renormalized to vegamag = 7.99 in filter Johnson/V</i> Time to Saturation (for a single exposure) = 18.29 seconds; 14,445 e- in 1.0s									
	2	(STIS.sp.10 06181)	(3) HD-86986	STIS/CCD, ACQ/PEAK, 0.2X0.09	G430L 4300 A				0.1 Secs (0.1 Secs)	
									[==>]	[1]
	<i>Comments: Castelli-Kurucz Models AIV 9250 4.0; Renormalized to vegamag = 7.99 in filter Johnson/V</i> Time to Saturation (for a single exposure) = 11.72 seconds; 442,002 e- in 0.1s									
3	(STIS.sp.91 6302)	(3) HD-86986	STIS/NUV-MAMA, ACCUM, 0.2X0.09	E230H 1763 A				1813 Secs (1813 Secs)		
								[==>]	[1]	
4	(STIS.sp.91 6302)	(3) HD-86986	STIS/NUV-MAMA, ACCUM, 0.2X0.09	E230H 1763 A				2817 Secs (2817 Secs)		
								[==>]	[2]	
5	(STIS.sp.91 6302)	(3) HD-86986	STIS/NUV-MAMA, ACCUM, 0.2X0.09	E230H 1763 A				2817 Secs (2817 Secs)		
								[==>]	[3]	

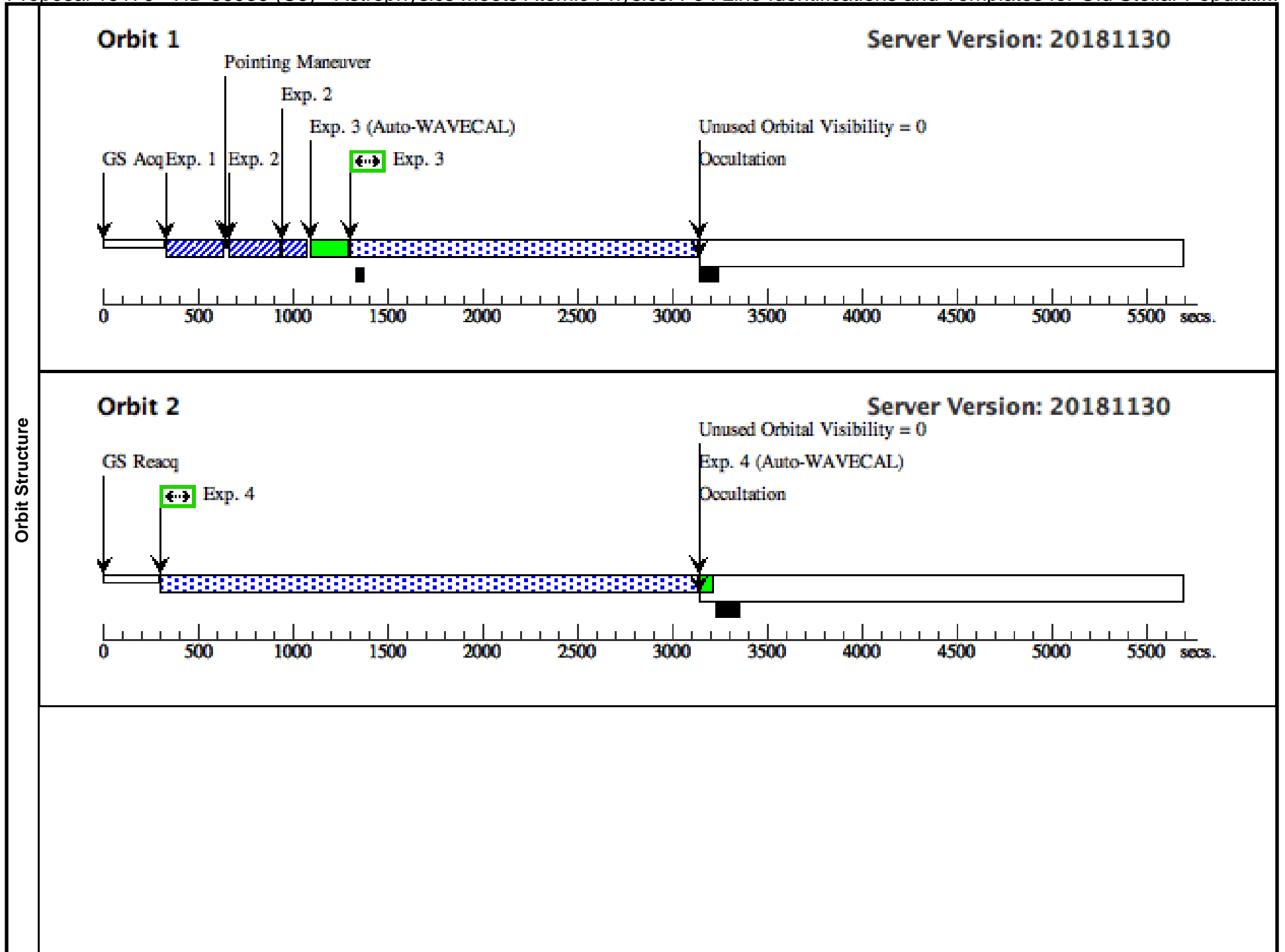

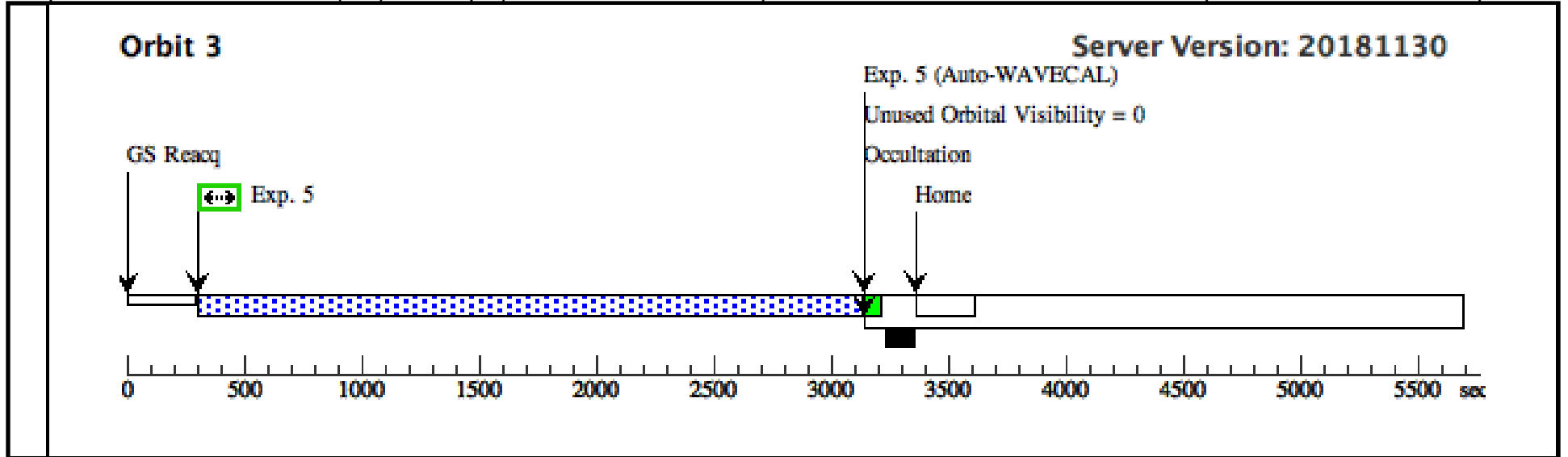

Proposal 15179 - HD 86986 (C6) - Astrophysics Meets Atomic Physics: Fe I Line Identifications and Templates for Old Stellar Populati...

Tue Dec 11 01:01:18 GMT 2018

Visit	<b>Proposal 15179, HD 86986 (C6), implementation</b> <b>Diagnostic Status: No Diagnostics</b> Scientific Instruments: STIS/NUV-MAMA, STIS/CCD Special Requirements: (none)										
	Fixed Targets	#	Name	Target Coordinates	Targ. Coord. Corrections	Fluxes	Miscellaneous				
		(3)	HD-86986	RA: 10 02 29.5659 (150.6231912d) Dec: +14 33 25.19 (14.55700d) Equinox: J2000	Proper Motion RA: 143.47 mas/yr Proper Motion Dec: -208.76 mas/yr Parallax: 0.00339" Epoch of Position: 2000 Radial Velocity: +9.5 km/sec	V=7.99+/-1	Reference Frame: ICRS				
	<i>Comments: T<sub>eff</sub> = 8000, log g = 3.2, [Fe/H] = -1.60; metal-poor blue horizontal branch star</i> Category=STAR Description=[A0-A3 V-IV]										
Exposures	#	Label (ETC Run)	Target	Config,Mode,Aperture	Spectral Els.	Opt. Params.	Special Reqs.	Groups	Exp. Time (Total)/[Actual Dur.]	Orbit	
	1	(STIS.ta.100 6168)	(3) HD-86986	STIS/CCD, ACQ, F25ND3	MIRROR				1 Secs (1 Secs)		
									[==>]	[1]	
		<i>Comments: Castelli-Kurucz Models A1V 9250 4.0; Renormalized to vegamag = 7.99 in filter Johnson/V</i> Time to Saturation (for a single exposure) = 18.29 seconds; 14,445 e- in 1.0s									
	2	(STIS.sp.10 06181)	(3) HD-86986	STIS/CCD, ACQ/PEAK, 0.2X0.09	G430L 4300 A				0.1 Secs (0.1 Secs)		
									[==>]	[1]	
	<i>Comments: Castelli-Kurucz Models A1V 9250 4.0; Renormalized to vegamag = 7.99 in filter Johnson/V</i> Time to Saturation (for a single exposure) = 11.72 seconds; 442,002 e- in 0.1s										
3	(STIS.sp.92 0226)	(3) HD-86986	STIS/NUV-MAMA, ACCUM, 0.2X0.09	E230H 2013 A				1813 Secs (1813 Secs)			
								[==>]	[1]		
4	(STIS.sp.92 0226)	(3) HD-86986	STIS/NUV-MAMA, ACCUM, 0.2X0.09	E230H 2013 A				2817 Secs (2817 Secs)			
								[==>]	[2]		
5	(STIS.sp.92 0226)	(3) HD-86986	STIS/NUV-MAMA, ACCUM, 0.2X0.09	E230H 2013 A				2817 Secs (2817 Secs)			
								[==>]	[3]		

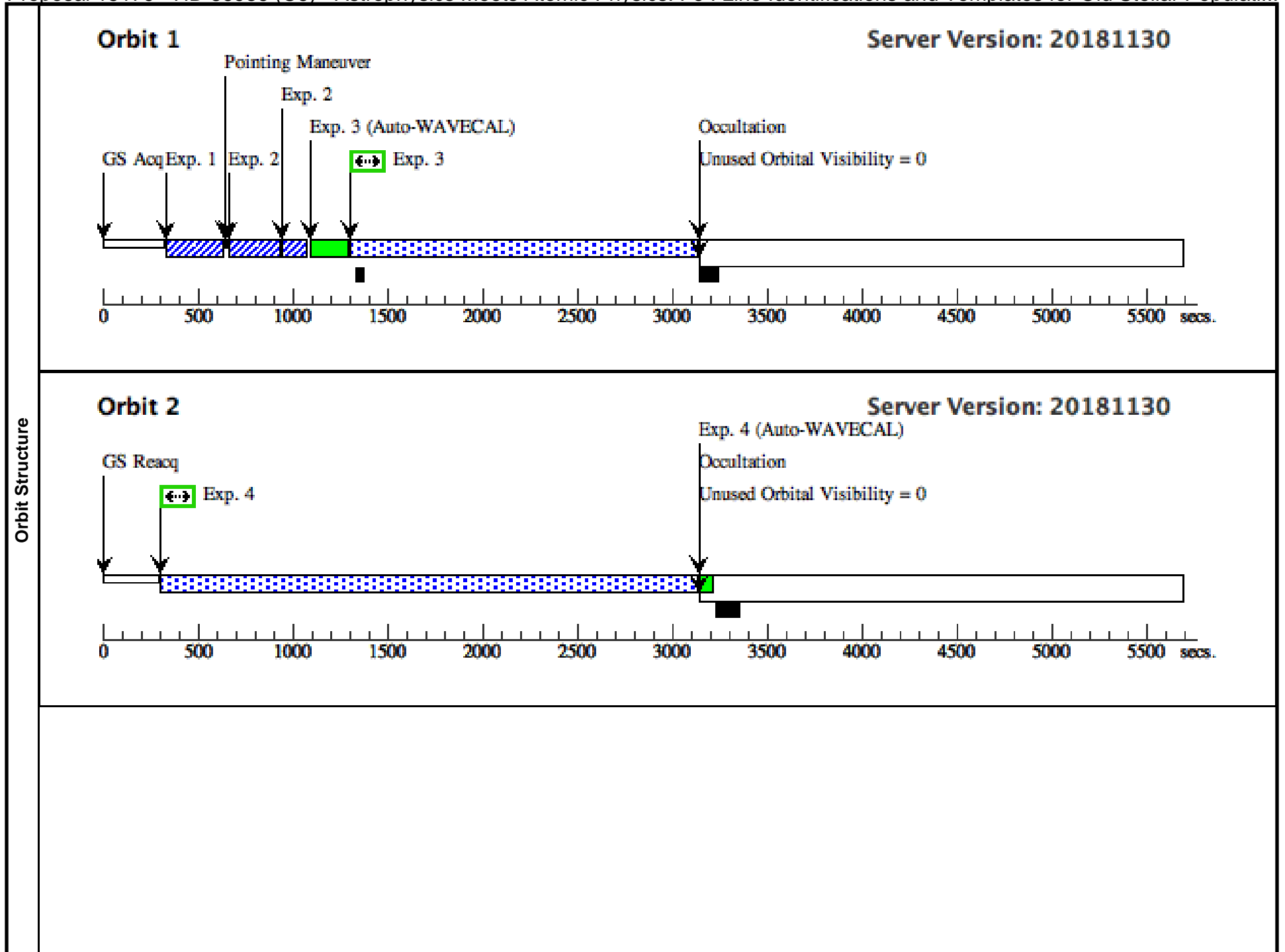

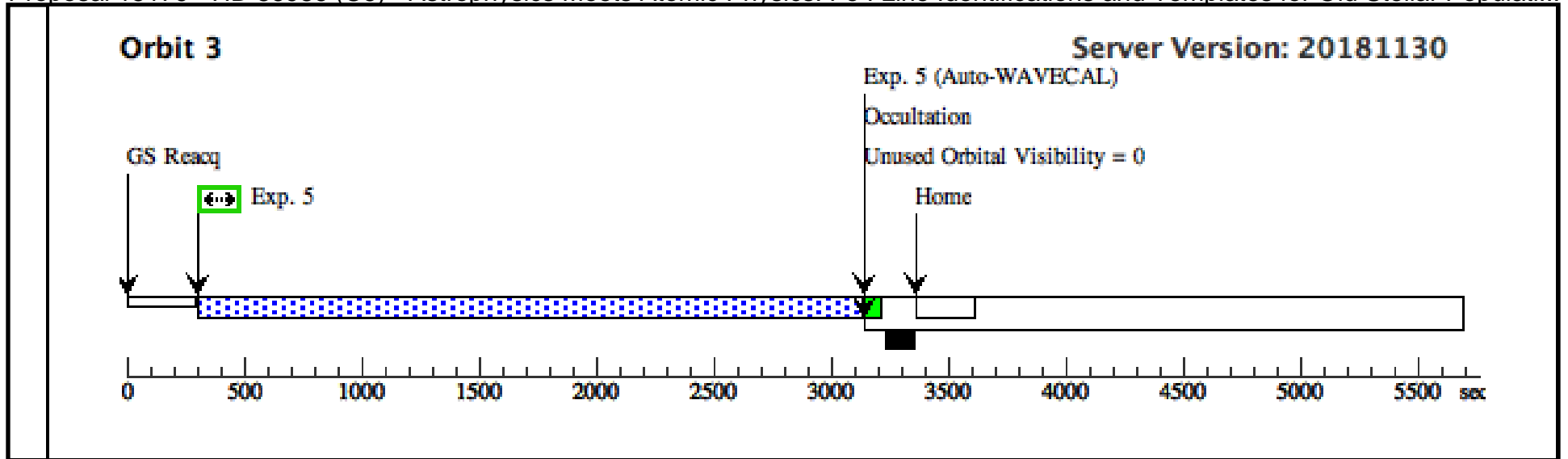

Proposal 15179 - HD 86986 (C7) - Astrophysics Meets Atomic Physics: Fe I Line Identifications and Templates for Old Stellar Populati...

Tue Dec 11 01:01:18 GMT 2018

Visit	<b>Proposal 15179, HD 86986 (C7), implementation</b> <b>Diagnostic Status: No Diagnostics</b> Scientific Instruments: STIS/NUV-MAMA, STIS/CCD Special Requirements: (none)																																																																																									
Fixed Targets	<table border="1"> <thead> <tr> <th>#</th> <th>Name</th> <th>Target Coordinates</th> <th>Targ. Coord. Corrections</th> <th>Fluxes</th> <th>Miscellaneous</th> </tr> </thead> <tbody> <tr> <td>(3)</td> <td>HD-86986</td> <td>RA: 10 02 29.5659 (150.6231912d) Dec: +14 33 25.19 (14.55700d) Equinox: J2000</td> <td>Proper Motion RA: 143.47 mas/yr Proper Motion Dec: -208.76 mas/yr Parallax: 0.00339" Epoch of Position: 2000 Radial Velocity: +9.5 km/sec</td> <td>V=7.99+/-1</td> <td>Reference Frame: ICRS</td> </tr> </tbody> </table> <p><i>Comments: T<sub>eff</sub> = 8000, log g = 3.2, [Fe/H] = -1.60; metal-poor blue horizontal branch star</i>                      Category=STAR                      Description=[A0-A3 V-IV]</p>										#	Name	Target Coordinates	Targ. Coord. Corrections	Fluxes	Miscellaneous	(3)	HD-86986	RA: 10 02 29.5659 (150.6231912d) Dec: +14 33 25.19 (14.55700d) Equinox: J2000	Proper Motion RA: 143.47 mas/yr Proper Motion Dec: -208.76 mas/yr Parallax: 0.00339" Epoch of Position: 2000 Radial Velocity: +9.5 km/sec	V=7.99+/-1	Reference Frame: ICRS																																																																				
#	Name	Target Coordinates	Targ. Coord. Corrections	Fluxes	Miscellaneous																																																																																					
(3)	HD-86986	RA: 10 02 29.5659 (150.6231912d) Dec: +14 33 25.19 (14.55700d) Equinox: J2000	Proper Motion RA: 143.47 mas/yr Proper Motion Dec: -208.76 mas/yr Parallax: 0.00339" Epoch of Position: 2000 Radial Velocity: +9.5 km/sec	V=7.99+/-1	Reference Frame: ICRS																																																																																					
Exposures	<table border="1"> <thead> <tr> <th>#</th> <th>Label (ETC Run)</th> <th>Target</th> <th>Config,Mode,Aperture</th> <th>Spectral Els.</th> <th>Opt. Params.</th> <th>Special Reqs.</th> <th>Groups</th> <th>Exp. Time (Total)/[Actual Dur.]</th> <th>Orbit</th> </tr> </thead> <tbody> <tr> <td>1</td> <td>(STIS.ta.100 6168)</td> <td>(3) HD-86986</td> <td>STIS/CCD, ACQ, F25ND3</td> <td>MIRROR</td> <td></td> <td></td> <td></td> <td>1 Secs (1 Secs) [==&gt;]</td> <td>[1]</td> </tr> <tr> <td colspan="10"><i>Comments: Castelli-Kurucz Models AIV 9250 4.0; Renormalized to vegamag = 7.99 in filter Johnson/V</i> <i>Time to Saturation (for a single exposure) = 18.29 seconds; 14,445 e- in 1.0s</i></td> </tr> <tr> <td>2</td> <td>(STIS.sp.10 06181)</td> <td>(3) HD-86986</td> <td>STIS/CCD, ACQ/PEAK, 0.2X0.09</td> <td>G430L 4300 A</td> <td></td> <td></td> <td></td> <td>0.1 Secs (0.1 Secs) [==&gt;]</td> <td>[1]</td> </tr> <tr> <td colspan="10"><i>Comments: Castelli-Kurucz Models AIV 9250 4.0; Renormalized to vegamag = 7.99 in filter Johnson/V</i> <i>Time to Saturation (for a single exposure) = 11.72 seconds; 442,002 e- in 0.1s</i></td> </tr> <tr> <td>3</td> <td>(STIS.sp.92 0226)</td> <td>(3) HD-86986</td> <td>STIS/NUV-MAMA, ACCUM, 0.2X0.09</td> <td>E230H 2013 A</td> <td></td> <td></td> <td></td> <td>1813 Secs (1813 Secs) [==&gt;]</td> <td>[1]</td> </tr> <tr> <td>4</td> <td>(STIS.sp.92 0226)</td> <td>(3) HD-86986</td> <td>STIS/NUV-MAMA, ACCUM, 0.2X0.09</td> <td>E230H 2013 A</td> <td></td> <td></td> <td></td> <td>2817 Secs (2817 Secs) [==&gt;]</td> <td>[2]</td> </tr> <tr> <td>5</td> <td>(STIS.sp.92 0226)</td> <td>(3) HD-86986</td> <td>STIS/NUV-MAMA, ACCUM, 0.2X0.09</td> <td>E230H 2013 A</td> <td></td> <td></td> <td></td> <td>2817 Secs (2817 Secs) [==&gt;]</td> <td>[3]</td> </tr> </tbody> </table>										#	Label (ETC Run)	Target	Config,Mode,Aperture	Spectral Els.	Opt. Params.	Special Reqs.	Groups	Exp. Time (Total)/[Actual Dur.]	Orbit	1	(STIS.ta.100 6168)	(3) HD-86986	STIS/CCD, ACQ, F25ND3	MIRROR				1 Secs (1 Secs) [==>]	[1]	<i>Comments: Castelli-Kurucz Models AIV 9250 4.0; Renormalized to vegamag = 7.99 in filter Johnson/V</i> <i>Time to Saturation (for a single exposure) = 18.29 seconds; 14,445 e- in 1.0s</i>										2	(STIS.sp.10 06181)	(3) HD-86986	STIS/CCD, ACQ/PEAK, 0.2X0.09	G430L 4300 A				0.1 Secs (0.1 Secs) [==>]	[1]	<i>Comments: Castelli-Kurucz Models AIV 9250 4.0; Renormalized to vegamag = 7.99 in filter Johnson/V</i> <i>Time to Saturation (for a single exposure) = 11.72 seconds; 442,002 e- in 0.1s</i>										3	(STIS.sp.92 0226)	(3) HD-86986	STIS/NUV-MAMA, ACCUM, 0.2X0.09	E230H 2013 A				1813 Secs (1813 Secs) [==>]	[1]	4	(STIS.sp.92 0226)	(3) HD-86986	STIS/NUV-MAMA, ACCUM, 0.2X0.09	E230H 2013 A				2817 Secs (2817 Secs) [==>]	[2]	5	(STIS.sp.92 0226)	(3) HD-86986	STIS/NUV-MAMA, ACCUM, 0.2X0.09	E230H 2013 A				2817 Secs (2817 Secs) [==>]	[3]
#	Label (ETC Run)	Target	Config,Mode,Aperture	Spectral Els.	Opt. Params.	Special Reqs.	Groups	Exp. Time (Total)/[Actual Dur.]	Orbit																																																																																	
1	(STIS.ta.100 6168)	(3) HD-86986	STIS/CCD, ACQ, F25ND3	MIRROR				1 Secs (1 Secs) [==>]	[1]																																																																																	
<i>Comments: Castelli-Kurucz Models AIV 9250 4.0; Renormalized to vegamag = 7.99 in filter Johnson/V</i> <i>Time to Saturation (for a single exposure) = 18.29 seconds; 14,445 e- in 1.0s</i>																																																																																										
2	(STIS.sp.10 06181)	(3) HD-86986	STIS/CCD, ACQ/PEAK, 0.2X0.09	G430L 4300 A				0.1 Secs (0.1 Secs) [==>]	[1]																																																																																	
<i>Comments: Castelli-Kurucz Models AIV 9250 4.0; Renormalized to vegamag = 7.99 in filter Johnson/V</i> <i>Time to Saturation (for a single exposure) = 11.72 seconds; 442,002 e- in 0.1s</i>																																																																																										
3	(STIS.sp.92 0226)	(3) HD-86986	STIS/NUV-MAMA, ACCUM, 0.2X0.09	E230H 2013 A				1813 Secs (1813 Secs) [==>]	[1]																																																																																	
4	(STIS.sp.92 0226)	(3) HD-86986	STIS/NUV-MAMA, ACCUM, 0.2X0.09	E230H 2013 A				2817 Secs (2817 Secs) [==>]	[2]																																																																																	
5	(STIS.sp.92 0226)	(3) HD-86986	STIS/NUV-MAMA, ACCUM, 0.2X0.09	E230H 2013 A				2817 Secs (2817 Secs) [==>]	[3]																																																																																	

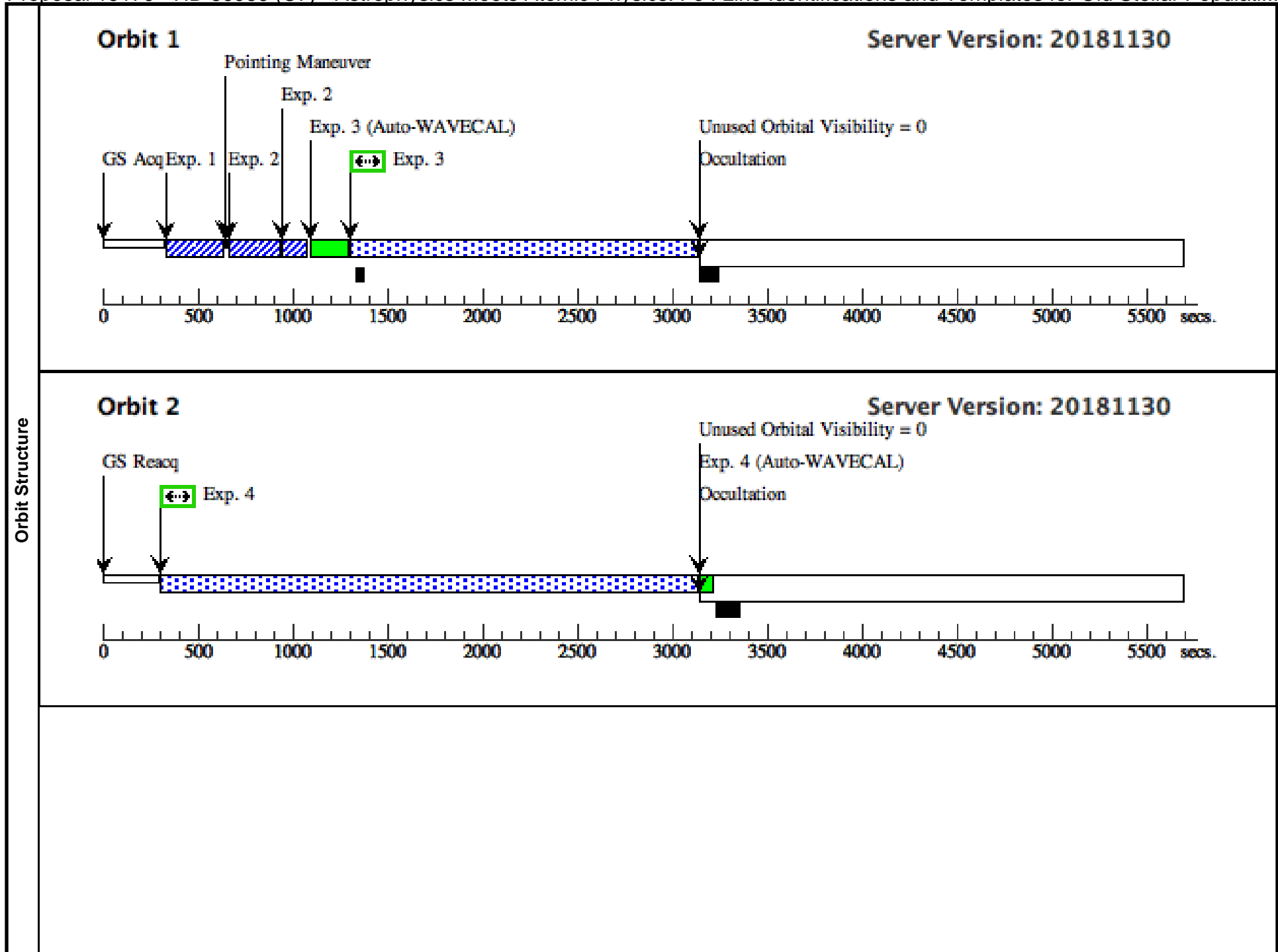

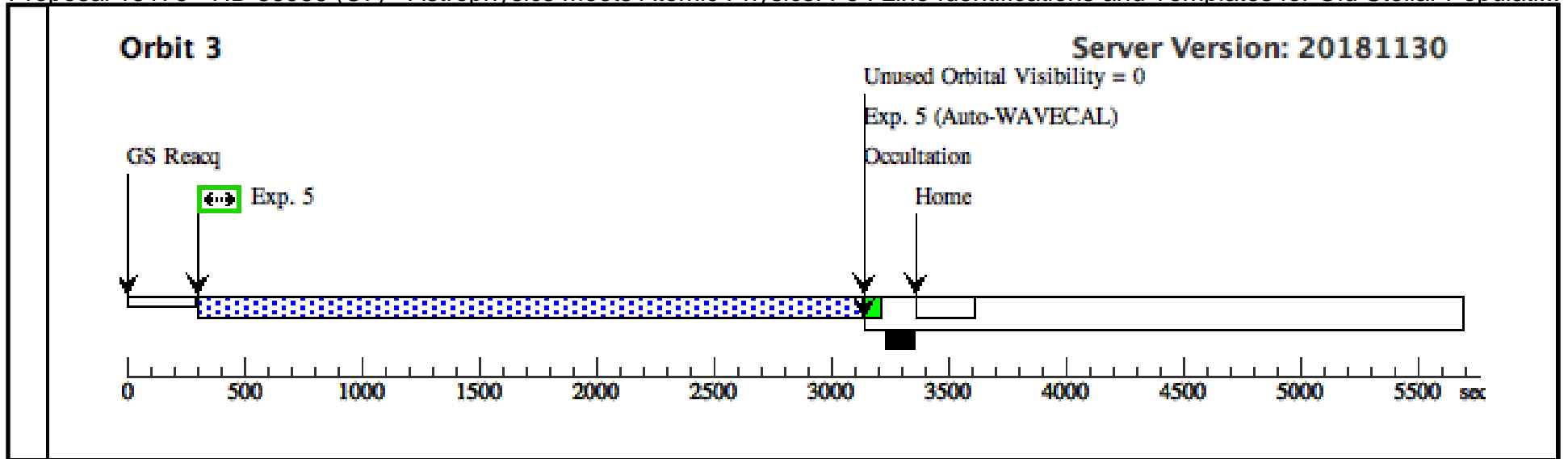

Proposal 15179 - HD 86986 (C8) - Astrophysics Meets Atomic Physics: Fe I Line Identifications and Templates for Old Stellar Populati...

Tue Dec 11 01:01:18 GMT 2018

Visit	<b>Proposal 15179, HD 86986 (C8), implementation</b> <b>Diagnostic Status: No Diagnostics</b> Scientific Instruments: STIS/NUV-MAMA, STIS/CCD Special Requirements: (none)										
	Fixed Targets	#	Name	Target Coordinates	Targ. Coord. Corrections	Fluxes	Miscellaneous				
		(3)	HD-86986	RA: 10 02 29.5659 (150.6231912d) Dec: +14 33 25.19 (14.55700d) Equinox: J2000	Proper Motion RA: 143.47 mas/yr Proper Motion Dec: -208.76 mas/yr Parallax: 0.00339" Epoch of Position: 2000 Radial Velocity: +9.5 km/sec	V=7.99+/-1	Reference Frame: ICRS				
	<i>Comments: T<sub>eff</sub> = 8000, log g = 3.2, [Fe/H] = -1.60; metal-poor blue horizontal branch star</i> Category=STAR Description=[A0-A3 V-IV]										
Exposures	#	Label (ETC Run)	Target	Config,Mode,Aperture	Spectral Els.	Opt. Params.	Special Reqs.	Groups	Exp. Time (Total)/[Actual Dur.]	Orbit	
	1	(STIS.ta.100 6168)	(3) HD-86986	STIS/CCD, ACQ, F25ND3	MIRROR				1 Secs (1 Secs)		
									[==>]	[1]	
		<i>Comments: Castelli-Kurucz Models AIV 9250 4.0; Renormalized to vegamag = 7.99 in filter Johnson/V</i> Time to Saturation (for a single exposure) = 18.29 seconds; 14,445 e- in 1.0s									
	2	(STIS.sp.10 06181)	(3) HD-86986	STIS/CCD, ACQ/PEAK, 0.2X0.09	G430L 4300 A				0.1 Secs (0.1 Secs)		
									[==>]	[1]	
	<i>Comments: Castelli-Kurucz Models AIV 9250 4.0; Renormalized to vegamag = 7.99 in filter Johnson/V</i> Time to Saturation (for a single exposure) = 11.72 seconds; 442,002 e- in 0.1s										
3	(STIS.sp.91 6561)	(3) HD-86986	STIS/NUV-MAMA, ACCUM, 0.2X0.09	E230H 2263 A				1813 Secs (1813 Secs)			
								[==>]	[1]		
4	(STIS.sp.91 6561)	(3) HD-86986	STIS/NUV-MAMA, ACCUM, 0.2X0.09	E230H 2263 A				2817 Secs (2817 Secs)			
								[==>]	[2]		
5	(STIS.sp.91 6570)	(3) HD-86986	STIS/NUV-MAMA, ACCUM, 0.2X0.09	E230H 2513 A				2817 Secs (2817 Secs)			
								[==>]	[3]		

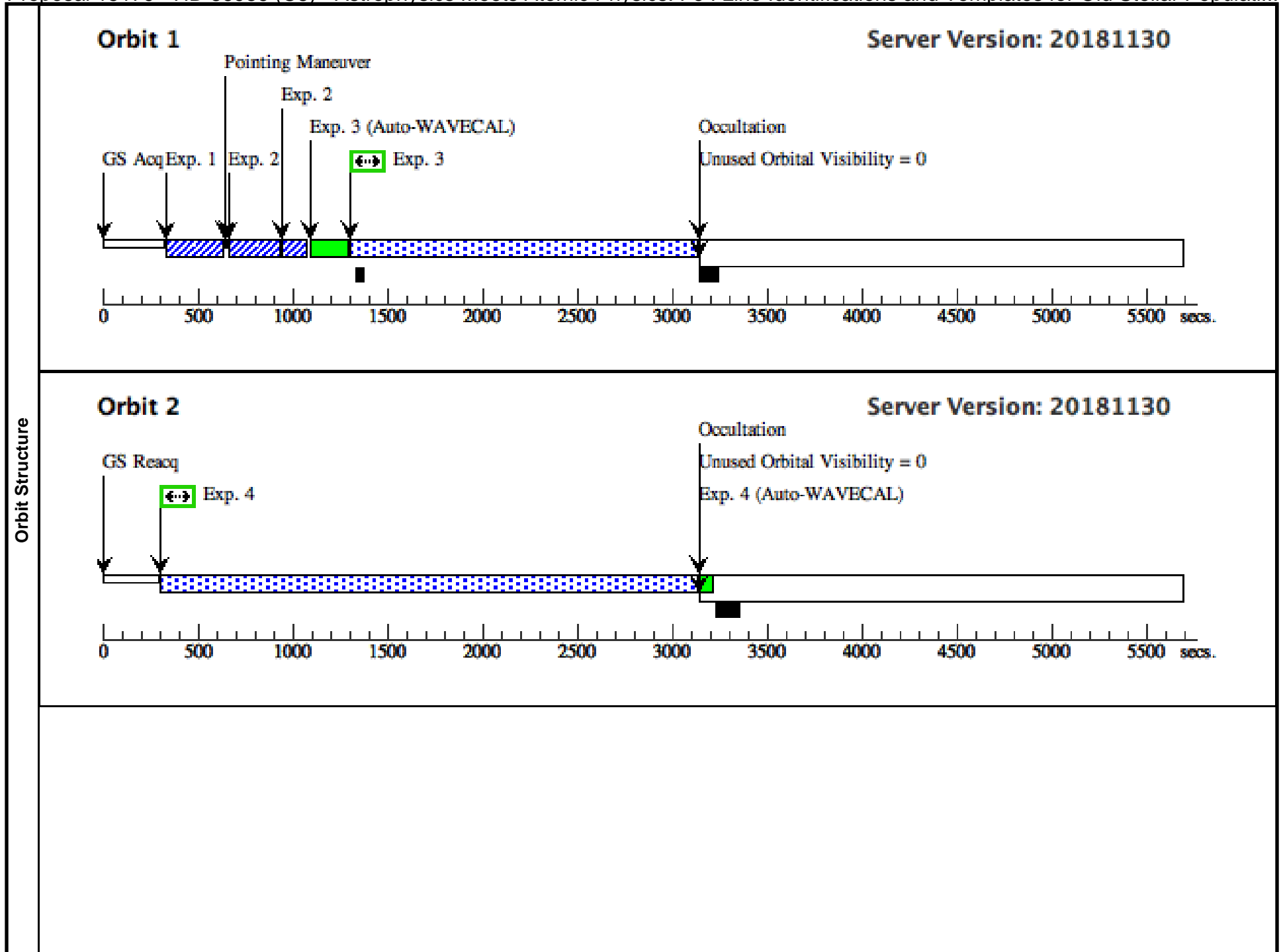

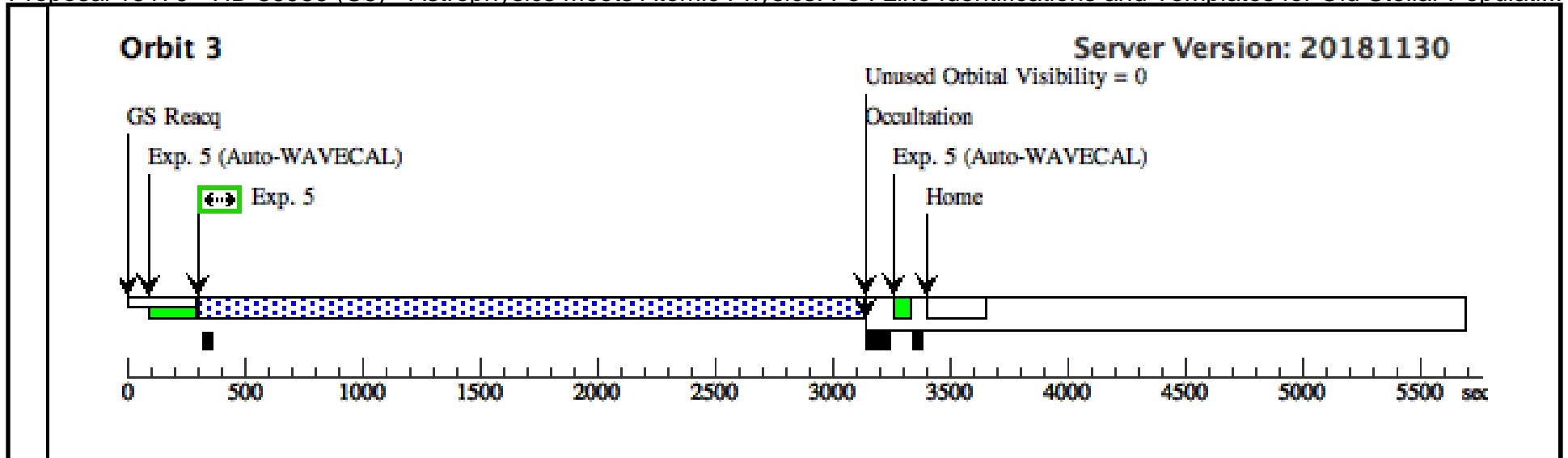

Proposal 15179 - HD 86986 (C9) - Astrophysics Meets Atomic Physics: Fe I Line Identifications and Templates for Old Stellar Populati...

Tue Dec 11 01:01:18 GMT 2018

Visit	<b>Proposal 15179, HD 86986 (C9), implementation</b> <b>Diagnostic Status: No Diagnostics</b> Scientific Instruments: STIS/NUV-MAMA, STIS/CCD Special Requirements: (none)										
	Fixed Targets	#	Name	Target Coordinates	Targ. Coord. Corrections	Fluxes	Miscellaneous				
		(3)	HD-86986	RA: 10 02 29.5659 (150.6231912d) Dec: +14 33 25.19 (14.55700d) Equinox: J2000	Proper Motion RA: 143.47 mas/yr Proper Motion Dec: -208.76 mas/yr Parallax: 0.00339" Epoch of Position: 2000 Radial Velocity: +9.5 km/sec	V=7.99+/-1	Reference Frame: ICRS				
	<i>Comments: T<sub>eff</sub> = 8000, log g = 3.2, [Fe/H] = -1.60; metal-poor blue horizontal branch star</i> Category=STAR Description=[A0-A3 V-IV]										
Exposures	#	Label (ETC Run)	Target	Config,Mode,Aperture	Spectral Els.	Opt. Params.	Special Reqs.	Groups	Exp. Time (Total)/[Actual Dur.]	Orbit	
	1	(STIS.ta.100 6168)	(3) HD-86986	STIS/CCD, ACQ, F25ND3	MIRROR				1 Secs (1 Secs)		
									[==>]	[1]	
		<i>Comments: Castelli-Kurucz Models AIV 9250 4.0; Renormalized to vegamag = 7.99 in filter Johnson/V</i> Time to Saturation (for a single exposure) = 18.29 seconds; 14,445 e- in 1.0s									
	2	(STIS.sp.10 06181)	(3) HD-86986	STIS/CCD, ACQ/PEAK, 0.2X0.09	G430L 4300 A				0.1 Secs (0.1 Secs)		
									[==>]	[1]	
	<i>Comments: Castelli-Kurucz Models AIV 9250 4.0; Renormalized to vegamag = 7.99 in filter Johnson/V</i> Time to Saturation (for a single exposure) = 11.72 seconds; 442,002 e- in 0.1s										
3	(STIS.sp.91 6564)	(3) HD-86986	STIS/NUV-MAMA, ACCUM, 0.2X0.09	E230H 3012 A				1813 Secs (1813 Secs)			
								[==>]	[1]		
4	(STIS.sp.91 6564)	(3) HD-86986	STIS/NUV-MAMA, ACCUM, 0.2X0.09	E230H 3012 A				2817 Secs (2817 Secs)			
								[==>]	[2]		
5	(STIS.sp.91 6565)	(3) HD-86986	STIS/NUV-MAMA, ACCUM, 0.2X0.09	E230H 2762 A				2817 Secs (2817 Secs)			
								[==>]	[3]		

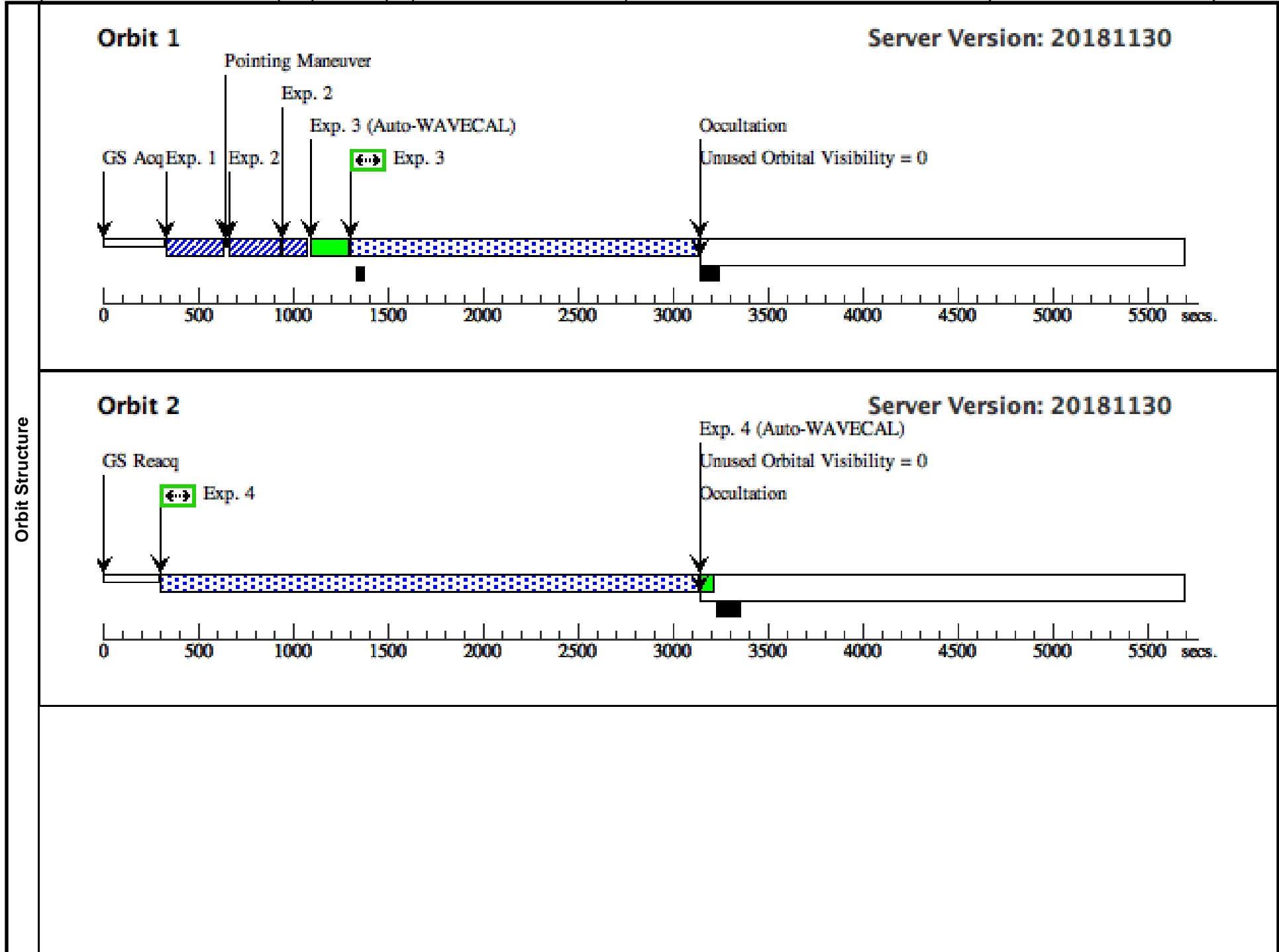

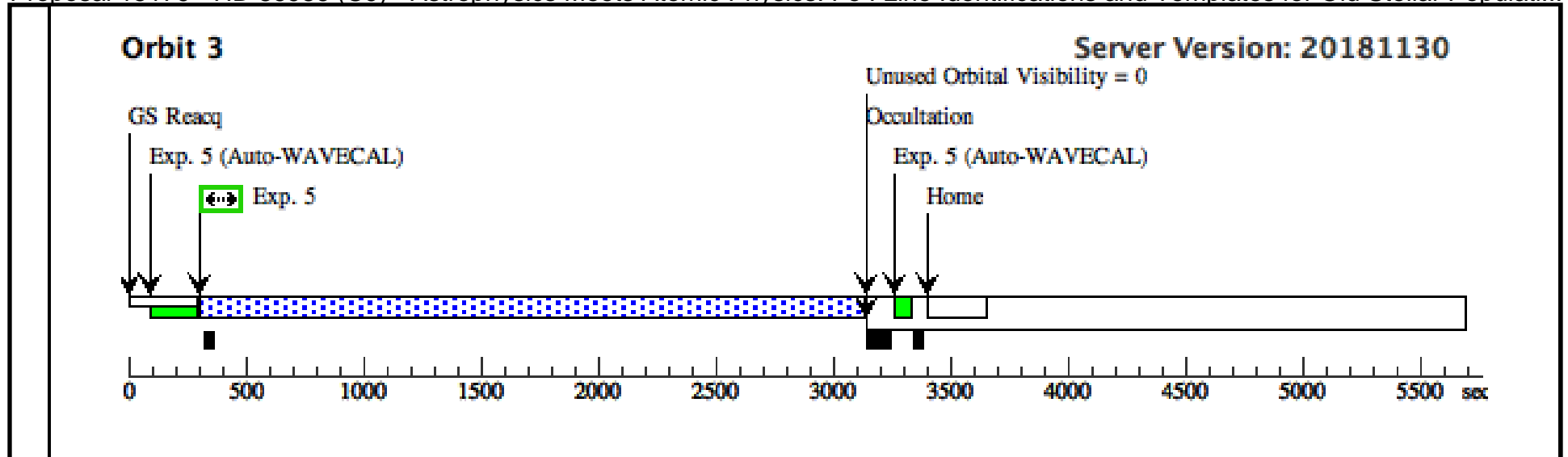

Proposal 15179 - HD 128167 (D0) - Astrophysics Meets Atomic Physics: Fe I Line Identifications and Templates for Old Stellar Popula...

Tue Dec 11 01:01:18 GMT 2018

<b>Visit</b>	<b>Proposal 15179, HD 128167 (D0), completed</b> <b>Diagnostic Status: Warning</b> Scientific Instruments: STIS/NUV-MAMA, STIS/CCD Special Requirements: (none)									
	(HD 128167 (D0)) Warning (Orbit Planner): ORBITAL VISIBILITY OVERRUN (HD 128167 (D0)) Warning (Orbit Planner): ORBITAL VISIBILITY OVERRUN									
<b>Fixed Targets</b>	<b>#</b>	<b>Name</b>	<b>Target Coordinates</b>	<b>Targ. Coord. Corrections</b>		<b>Fluxes</b>	<b>Miscellaneous</b>			
	(4)	HD-128167	RA: 14 34 40.8170 (218.6700708d) Dec: +29 44 42.46 (29.74513d) Equinox: J2000	Proper Motion RA: 188.35 mas/yr Proper Motion Dec: 131.77 mas/yr Parallax: 0.06316" Epoch of Position: 2000 Radial Velocity: +0.37 km/sec		V=4.47+/-1	Reference Frame: ICRS			
Comments: $T_{\text{eff}} = 6850$ , $\log g = 4.3$ , $[Fe/H] = -0.40$ ; mildly metal-poor blue straggler Category=STAR Description=[F3-F9]										
<b>Exposures</b>	<b>#</b>	<b>Label (ETC Run)</b>	<b>Target</b>	<b>Config,Mode,Aperture</b>	<b>Spectral Els.</b>	<b>Opt. Params.</b>	<b>Special Reqs.</b>	<b>Groups</b>	<b>Exp. Time (Total)/[Actual Dur.]</b>	<b>Orbit</b>
	1	(STIS.ta.100 (4) HD-128167 6208)	(4) HD-128167	STIS/CCD, ACQ, F25ND3	MIRROR				0.1 Secs (0.1 Secs) [==>]	[1]
	Comments: Castelli-Kurucz Models F2V 7000 4.0; Renormalized to vegamag = 4.47 in filter Johnson/V Time to Saturation (for a single exposure) = 0.70 seconds; 39,899 e- in 0.1s (Note: assumed spectral type differs from SIMBAD F4V owing to metal deficiency of star.)									
	2	(STIS.sp.10 (4) HD-128167 06206)	(4) HD-128167	STIS/CCD, ACQ/PEAK, 0.2X0.09	G430L 4300 A				0.1 Secs (0.1 Secs) [==>]	[1]
	Comments: Castelli-Kurucz Models F2V 7000 4.0; Renormalized to vegamag = 4.47 in filter Johnson/V Time to Saturation (for a single exposure) = 0.59 seconds; 9,271,631 e- in 0.1s (Note: assumed spectral type differs from SIMBAD F4V owing to metal deficiency of star.)									
3	(STIS.sp.91 (4) HD-128167 9784)	(4) HD-128167	STIS/NUV-MAMA, ACCUM, 0.2X0.09	E230H 2263 A				878 Secs X 2 (1756 Secs) [==>(Copy 1)] [==>(Copy 2)]	[1]	
Comments: GCR=111K; not a variable source										
4	(STIS.sp.10 (4) HD-128167 06230)	(4) HD-128167	STIS/NUV-MAMA, ACCUM, 0.2X0.06	E230M 1978 A				1418 Secs X 2 (2836 Secs) [==>(Copy 1)] [==>(Copy 2)]	[2]	
Comments: GCR=119K; not a variable source										

