



15182 - The Origin of Ultra-Faint Galaxies

Cycle: 25, Proposal Category: GO

(Availability Mode: SUPPORTED)

INVESTIGATORS

<i>Name</i>	<i>Institution</i>	<i>E-Mail</i>
Prof. David J. Sand (PI) (Contact)	University of Arizona	dave.j.sand@gmail.com
Dr. Nelson Caldwell (CoI)	Smithsonian Institution Astrophysical Observatory	ncaldwell@cfa.harvard.edu
Dr. Brian Mcleod (CoI)	Smithsonian Institution Astrophysical Observatory	bmcleod@cfa.harvard.edu
Dr. Edward W. Olszewski (CoI)	University of Arizona	edo@as.arizona.edu
Prof. Anil C. Seth (CoI)	University of Utah	aseth@astro.utah.edu
Prof. Jay Strader (CoI)	Michigan State University	strader@pa.msu.edu
Dr. Beth Willman (CoI)	LSST	bwillman@lsst.org
Prof. Dennis Zaritsky (CoI)	University of Arizona	dennis.zaritsky@gmail.com
Dr. Michelle L.M. Collins (CoI) (ESA Member)	University of Surrey	m.collins@surrey.ac.uk
Dr. Denija Crnojevic (CoI)	University of Tampa	dcrnojevic@ut.edu

VISITS

<i>Visit</i>	<i>Targets used in Visit</i>	<i>Configurations used in Visit</i>	<i>Orbits Used</i>	<i>Last Orbit Planner Run</i>	<i>OP Current with Visit?</i>
01	(3) LEOVNE	ACS/WFC WFC3/UVIS	2	16-Apr-2019 16:01:37.0	yes
02	(3) LEOVNE	ACS/WFC WFC3/UVIS	2	16-Apr-2019 16:01:39.0	yes
03	(1) HERCEAST	ACS/WFC WFC3/UVIS	2	16-Apr-2019 16:01:40.0	yes

Proposal 15182 (STScI Edit Number: 6, Created: Tuesday, April 16, 2019 at 3:01:57 PM Eastern Standard Time) - Overview

<i>Visit</i>	<i>Targets used in Visit</i>	<i>Configurations used in Visit</i>	<i>Orbits Used</i>	<i>Last Orbit Planner Run</i>	<i>OP Current with Visit?</i>
53	(1) HERCEAST	ACS/WFC WFC3/UVIS	2	16-Apr-2019 16:01:41.0	yes
54	(1) HERCEAST	ACS/WFC WFC3/UVIS	3	16-Apr-2019 16:01:42.0	yes
56	(1) HERCEAST	ACS/WFC WFC3/UVIS	3	16-Apr-2019 16:01:44.0	yes
04	(1) HERCEAST	ACS/WFC WFC3/UVIS	3	16-Apr-2019 16:01:45.0	yes
05	(1) HERCEAST	ACS/WFC WFC3/UVIS	2	16-Apr-2019 16:01:46.0	yes
06	(1) HERCEAST	ACS/WFC WFC3/UVIS	3	16-Apr-2019 16:01:48.0	yes
07	(2) HERCWEST	ACS/WFC WFC3/UVIS	2	16-Apr-2019 16:01:49.0	yes
08	(2) HERCWEST	ACS/WFC WFC3/UVIS	3	16-Apr-2019 16:01:50.0	yes
09	(2) HERCWEST	ACS/WFC WFC3/UVIS	2	16-Apr-2019 16:01:52.0	yes
10	(2) HERCWEST	ACS/WFC WFC3/UVIS	3	16-Apr-2019 16:01:53.0	yes
58	(2) HERCWEST	ACS/WFC WFC3/UVIS	3	16-Apr-2019 16:01:55.0	yes
60	(2) HERCWEST	ACS/WFC WFC3/UVIS	3	16-Apr-2019 16:01:56.0	yes
61	(1) HERCEAST	ACS/WFC WFC3/UVIS	1	16-Apr-2019 16:01:57.0	yes

39 Total Orbits Used

ABSTRACT

We request 24 orbits of HST/ACS to obtain imaging in F606W and F814W of apparent tidal features in two ultra-faint dwarf galaxies: Hercules and Leo V. This will enable us to test whether the stars in ultra-faint galaxies--as a population--have been affected by Galactic tides. Most of the new dwarfs show signs of tidal interaction in ground-based photometry, several have measured ellipticities greater than ~ 0.5 , and kinematics of a subset show velocity gradients. These ubiquitous hints for tidal effects among distant dwarfs is particularly surprising and suggestive. If most ultra-faint dwarfs are disturbed by tides, then recent tests of galaxy formation in the near field have unstable foundations.

HST resolution provides an opportunity to assess whether tidal features (accompanied by tentative kinematic gradients) seen in ground-based observations of Hercules and Leo V are genuine or are instead clumps of compact background galaxies masquerading as stellar debris. In Hercules, a further test is possible: searching for a distance gradient along the stretched body of the galaxy. Parallel pointings will sample similar dwarf-centric radii away from the tidal features, assuring an unambiguous result. Whether we confirm or rule out the presence of stellar loss in these objects, the consequences are important--the origin of the ultra-faint dwarfs tells us the lower limit to both galaxy formation and the number of dark matter subhalos inhabiting the Milky Way.

This program is only possible with HST: its exquisite resolution can separate compact galaxies from main sequence dwarf stars at faint magnitudes, which even the best multi-band ground-based schemes struggle with.

OBSERVING DESCRIPTION

We request 24 orbits of HST/ACS to obtain imaging in F606W and F814W of fields in the ultra-faint dwarf galaxies Hercules and Leo V, the two distant Milky Way satellites with both tentative photometric signs of tidal disturbance and velocity gradients. In concert with parallel WFC3 observations, this imaging will enable us to test whether the stars in ultra-faint galaxies have been strongly affected by tides.

We will target candidate debris streams identified in ground-based data with one or two Advanced Camera for Surveys/Wide Field Camera (ACS/WFC) pointings for each dwarf. Coordinated parallel observations with WFC3 at similar projected radii will provide control color-magnitude diagrams (CMDs) to ensure decisive positive or negative detections of tidal material, and to assess the impact of foreground star/background galaxy contaminants. Central pointings are needed to have CMDs to compare to the potential debris, and these data already exist in the HST archive at sufficient depths for both targets.

For Leo V, we have simulated how many stars we expect to detect if the overdensities seen in the ground-based data are due entirely to tidal material

or entirely due to unresolved galaxies. To make a 5-sigma detection of the overdensity, we need to detect 20-30 main sequence stars. We have chosen the standard F606W and F814W filter combination for their sensitivity and for consistency with the archived central pointing of Leo V (from GO-14770). By reaching depths of F606W=27.0 and F814W=26.5 we can ensure that we will detect at least 30 stars if the outlying Leo V field consists of tidal debris.

For Hercules, If the tentative measurement of a velocity gradient along Hercules is correct (Aden et al. 2009; Deason et al. 2012), we can expect to measure a ~ 10 kpc distance gradient between our two ACS pointings, as predicted by the orbital calculations of Martin & Jin (2010), where Hercules is essentially a stellar over-density in a larger stream near apocenter. To model this scenario, we combined simulations of our ACS observations with the central archival data and a model of Hercules with a 10 kpc gradient. With data of the same quality as the central pointing, we can measure a gradient with an uncertainty of ~ 2 kpc, which should result in a robust 5-sigma detection if the gradient is in fact 10 kpc across our fields. The depth required here is greater than the depth required to verify the tidal debris (similar to that discussed for the Leo V case above), but will result in significant additional scientific gain by providing detailed information on the tidal disruption that could be occurring in Hercules

Proposal 15182 - LeoVNE Visit 1 -- F606W (01) - The Origin of Ultra-Faint Galaxies

Tue Apr 16 20:01:57 GMT 2019

Visit	Proposal 15182, LeoVNE Visit 1 -- F606W (01), completed Diagnostic Status: Warning Scientific Instruments: WFC3/UVIS, ACS/WFC Special Requirements: ORIENT 65D TO 95 D <i>Comments: We are splitting our four orbits of Leo V NE into two visits, one for each filter. The initial visit should have an ORIENT between 65 and 95 degrees. Coordinated parallels with WFC3 will be taken. The second visit (LeoVNE Visit 2) should have the same ORIENT as LeoVNE Visit 1.</i>																																																				
	(LeoVNE Visit 1 -- F606W (01)) Warning (Orbit Planner): ORBITAL VISIBILITY OVERRUN (LeoVNE Visit 1 -- F606W (01)) Warning (Orbit Planner): ORBITAL VISIBILITY OVERRUN																																																				
Diagnosics																																																					
Patterns	<table border="1"> <thead> <tr> <th>#</th> <th>Primary Pattern</th> <th>Secondary Pattern</th> <th>Exposures</th> </tr> </thead> <tbody> <tr> <td>(1)</td> <td> Pattern Type=ACS-WFC-DITHER-BOX Purpose=DITHER Number Of Points=4 Point Spacing=0.262 Line Spacing=0.192 </td> <td> Coordinate Frame=POS-TARG Pattern Orientation=18.39 Angle Between Sides=68.14 Center Pattern=false </td> <td>(1-2)</td> </tr> </tbody> </table>	#	Primary Pattern	Secondary Pattern	Exposures	(1)	Pattern Type=ACS-WFC-DITHER-BOX Purpose=DITHER Number Of Points=4 Point Spacing=0.262 Line Spacing=0.192	Coordinate Frame=POS-TARG Pattern Orientation=18.39 Angle Between Sides=68.14 Center Pattern=false	(1-2)																																												
	#	Primary Pattern	Secondary Pattern	Exposures																																																	
(1)	Pattern Type=ACS-WFC-DITHER-BOX Purpose=DITHER Number Of Points=4 Point Spacing=0.262 Line Spacing=0.192	Coordinate Frame=POS-TARG Pattern Orientation=18.39 Angle Between Sides=68.14 Center Pattern=false	(1-2)																																																		
Fixed Targets	<table border="1"> <thead> <tr> <th>#</th> <th>Name</th> <th>Target Coordinates</th> <th>Targ. Coord. Corrections</th> <th>Fluxes</th> <th>Miscellaneous</th> </tr> </thead> <tbody> <tr> <td>(3)</td> <td>LEOVNE</td> <td> RA: 11 31 30.1368 (172.8755700d) Dec: +02 18 21.00 (2.30583d) Equinox: J2000 </td> <td></td> <td>V=16.0+/-0.2</td> <td>Reference Frame: ICRS</td> </tr> </tbody> </table>	#	Name	Target Coordinates	Targ. Coord. Corrections	Fluxes	Miscellaneous	(3)	LEOVNE	RA: 11 31 30.1368 (172.8755700d) Dec: +02 18 21.00 (2.30583d) Equinox: J2000		V=16.0+/-0.2	Reference Frame: ICRS																																								
	#	Name	Target Coordinates	Targ. Coord. Corrections	Fluxes	Miscellaneous																																															
(3)	LEOVNE	RA: 11 31 30.1368 (172.8755700d) Dec: +02 18 21.00 (2.30583d) Equinox: J2000		V=16.0+/-0.2	Reference Frame: ICRS																																																
<i>Comments: This target is centered on a stellar overdensity far from the center of the dwarf spheroidal, Leo V.</i> Category=GALAXY Description=[DWARF SPHEROIDAL]																																																					
Exposures	<table border="1"> <thead> <tr> <th>#</th> <th>Label</th> <th>Target</th> <th>Config,Mode,Aperture</th> <th>Spectral Els.</th> <th>Opt. Params.</th> <th>Special Reqs.</th> <th>Groups</th> <th>Exp. Time (Total)/[Actual Dur.]</th> <th>Orbit</th> </tr> </thead> <tbody> <tr> <td rowspan="4">1</td> <td rowspan="4">(3) LEOVNE</td> <td rowspan="4">ACS/WFC, ACCUM, WFC</td> <td rowspan="4">F606W</td> <td rowspan="4"></td> <td rowspan="4"></td> <td rowspan="4"></td> <td>Pattern 1, Exps 1-2 in LeoVNE Visit 1 -- F606W (01) (1)</td> <td>1200.0 Secs (5174 Secs)</td> <td></td> </tr> <tr> <td>Prime + Parallel Group 1-2 in Pattern 1, Exps 1-2 in LeoVNE Visit 1 -- F606W (01)</td> <td>[==>1245.0 Secs (Pattern 1)]</td> <td>[1]</td> </tr> <tr> <td>Prime + Parallel Group 1-2 in Pattern 1, Exps 1-2 in LeoVNE Visit 1 -- F606W (01)</td> <td>[==>1245.0 Secs (Pattern 2)]</td> <td></td> </tr> <tr> <td>Prime + Parallel Group 1-2 in Pattern 1, Exps 1-2 in LeoVNE Visit 1 -- F606W (01)</td> <td>[==>1342.0 Secs (Pattern 3)]</td> <td>[2]</td> </tr> <tr> <td rowspan="4">2</td> <td rowspan="4">(3) LEOVNE</td> <td rowspan="4">WFC3/UVIS, ACCUM, UVIS</td> <td rowspan="4">F606W</td> <td rowspan="4"></td> <td rowspan="4"></td> <td rowspan="4"></td> <td>Pattern 1, Exps 1-2 in LeoVNE Visit 1 -- F606W (01) (1)</td> <td>1200. Secs (5264 Secs)</td> <td></td> </tr> <tr> <td>Prime + Parallel Group 1-2 in Pattern 1, Exps 1-2 in LeoVNE Visit 1 -- F606W (01)</td> <td>[==>1305.0 Secs (Pattern 1)]</td> <td>[1]</td> </tr> <tr> <td>Prime + Parallel Group 1-2 in Pattern 1, Exps 1-2 in LeoVNE Visit 1 -- F606W (01)</td> <td>[==>1255.0 Secs (Pattern 2)]</td> <td></td> </tr> <tr> <td>Prime + Parallel Group 1-2 in Pattern 1, Exps 1-2 in LeoVNE Visit 1 -- F606W (01)</td> <td>[==>1352.0 Secs (Pattern 3)]</td> <td>[2]</td> </tr> </tbody> </table>	#	Label	Target	Config,Mode,Aperture	Spectral Els.	Opt. Params.	Special Reqs.	Groups	Exp. Time (Total)/[Actual Dur.]	Orbit	1	(3) LEOVNE	ACS/WFC, ACCUM, WFC	F606W				Pattern 1, Exps 1-2 in LeoVNE Visit 1 -- F606W (01) (1)	1200.0 Secs (5174 Secs)		Prime + Parallel Group 1-2 in Pattern 1, Exps 1-2 in LeoVNE Visit 1 -- F606W (01)	[==>1245.0 Secs (Pattern 1)]	[1]	Prime + Parallel Group 1-2 in Pattern 1, Exps 1-2 in LeoVNE Visit 1 -- F606W (01)	[==>1245.0 Secs (Pattern 2)]		Prime + Parallel Group 1-2 in Pattern 1, Exps 1-2 in LeoVNE Visit 1 -- F606W (01)	[==>1342.0 Secs (Pattern 3)]	[2]	2	(3) LEOVNE	WFC3/UVIS, ACCUM, UVIS	F606W				Pattern 1, Exps 1-2 in LeoVNE Visit 1 -- F606W (01) (1)	1200. Secs (5264 Secs)		Prime + Parallel Group 1-2 in Pattern 1, Exps 1-2 in LeoVNE Visit 1 -- F606W (01)	[==>1305.0 Secs (Pattern 1)]	[1]	Prime + Parallel Group 1-2 in Pattern 1, Exps 1-2 in LeoVNE Visit 1 -- F606W (01)	[==>1255.0 Secs (Pattern 2)]		Prime + Parallel Group 1-2 in Pattern 1, Exps 1-2 in LeoVNE Visit 1 -- F606W (01)	[==>1352.0 Secs (Pattern 3)]	[2]				
	#	Label	Target	Config,Mode,Aperture	Spectral Els.	Opt. Params.	Special Reqs.	Groups	Exp. Time (Total)/[Actual Dur.]	Orbit																																											
	1	(3) LEOVNE	ACS/WFC, ACCUM, WFC	F606W				Pattern 1, Exps 1-2 in LeoVNE Visit 1 -- F606W (01) (1)	1200.0 Secs (5174 Secs)																																												
								Prime + Parallel Group 1-2 in Pattern 1, Exps 1-2 in LeoVNE Visit 1 -- F606W (01)	[==>1245.0 Secs (Pattern 1)]	[1]																																											
Prime + Parallel Group 1-2 in Pattern 1, Exps 1-2 in LeoVNE Visit 1 -- F606W (01)								[==>1245.0 Secs (Pattern 2)]																																													
Prime + Parallel Group 1-2 in Pattern 1, Exps 1-2 in LeoVNE Visit 1 -- F606W (01)								[==>1342.0 Secs (Pattern 3)]	[2]																																												
2	(3) LEOVNE	WFC3/UVIS, ACCUM, UVIS	F606W				Pattern 1, Exps 1-2 in LeoVNE Visit 1 -- F606W (01) (1)	1200. Secs (5264 Secs)																																													
							Prime + Parallel Group 1-2 in Pattern 1, Exps 1-2 in LeoVNE Visit 1 -- F606W (01)	[==>1305.0 Secs (Pattern 1)]	[1]																																												
							Prime + Parallel Group 1-2 in Pattern 1, Exps 1-2 in LeoVNE Visit 1 -- F606W (01)	[==>1255.0 Secs (Pattern 2)]																																													
							Prime + Parallel Group 1-2 in Pattern 1, Exps 1-2 in LeoVNE Visit 1 -- F606W (01)	[==>1352.0 Secs (Pattern 3)]	[2]																																												

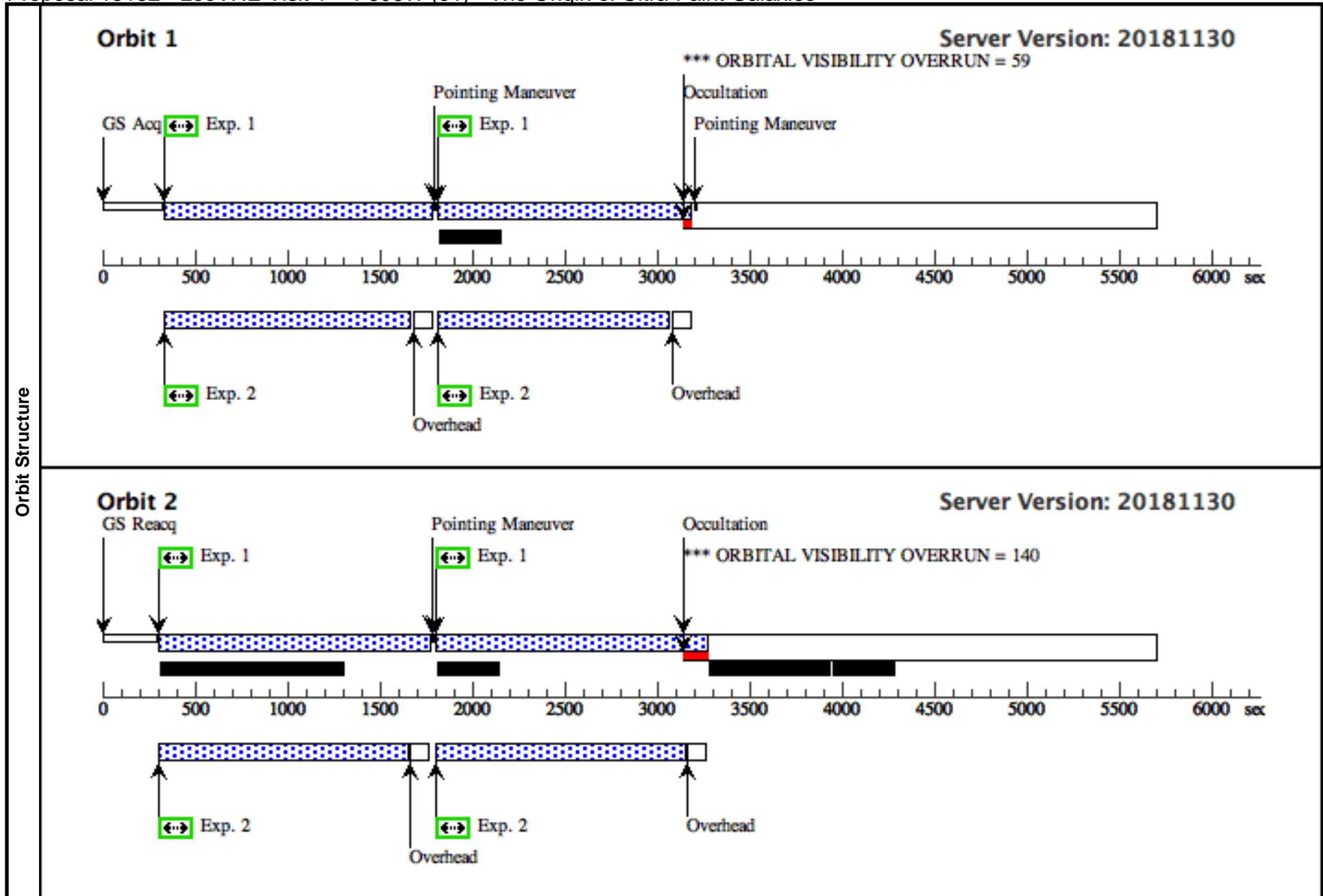

Proposal 15182 - LeoVNE Visit 2 -- F814W (02) - The Origin of Ultra-Faint Galaxies

Tue Apr 16 20:01:58 GMT 2019

Visit	Proposal 15182, LeoVNE Visit 2 -- F814W (02), completed Diagnostic Status: Warning Scientific Instruments: WFC3/UVIS, ACS/WFC Special Requirements: SAME ORIENT AS 01 <i>Comments: We are splitting our four orbits of Leo V NE into two visits, one for each filter. The initial visit should have an ORIENT between 65 and 95 degrees. Coordinated parallels with WFC3 will be taken. The second visit (LeoVNE Visit 2) should have the same ORIENT as LeoVNE Visit 1.</i>									
	Diagnosics (LeoVNE Visit 2 -- F814W (02)) Warning (Orbit Planner): ORBITAL VISIBILITY OVERRUN (LeoVNE Visit 2 -- F814W (02)) Warning (Orbit Planner): ORBITAL VISIBILITY OVERRUN									
Patterns	#	Primary Pattern	Secondary Pattern	Exposures						
	(1)	Pattern Type=ACS-WFC-DITHER-BOX Purpose=DITHER Number Of Points=4 Point Spacing=0.262 Line Spacing=0.192	Coordinate Frame=POS-TARG Pattern Orientation=18.39 Angle Between Sides=68.14 Center Pattern=false		(1-2)					
Fixed Targets	#	Name	Target Coordinates	Targ. Coord. Corrections	Fluxes	Miscellaneous				
	(3)	LEOVNE	RA: 11 31 30.1368 (172.8755700d) Dec: +02 18 21.00 (2.30583d) Equinox: J2000		V=16.0+/-0.2	Reference Frame: ICRS				
<i>Comments: This target is centered on a stellar overdensity far from the center of the dwarf spheroidal, Leo V.</i> Category=GALAXY Description=[DWARF SPHEROIDAL]										
Exposures	#	Label	Target	Config,Mode,Aperture	Spectral Els.	Opt. Params.	Special Reqs.	Groups	Exp. Time (Total)/[Actual Dur.]	Orbit
	1	(3) LEOVNE		ACS/WFC, ACCUM, WFC	F814W			Pattern 1, Exps 1-2 in LeoVNE Visit 2 -- F814W (02) (1)	1200.0 Secs (5174 Secs)	
								Prime + Parallel Group 1-2 in Pattern 1, Exps 1-2 in LeoVNE Visit 2 -- F814W (02)	[==>1245.0 Secs (Pattern 1)]	[1]
									[==>1245.0 Secs (Pattern 2)]	
								Prime + Parallel Group 1-2 in Pattern 1, Exps 1-2 in LeoVNE Visit 2 -- F814W (02)	[==>1342.0 Secs (Pattern 3)]	[2]
									[==>1342.0 Secs (Pattern 4)]	
2	(3) LEOVNE		WFC3/UVIS, ACCUM, UVIS	F814W				Pattern 1, Exps 1-2 in LeoVNE Visit 2 -- F814W (02) (1)	1200. Secs (5264 Secs)	
								Prime + Parallel Group 1-2 in Pattern 1, Exps 1-2 in LeoVNE Visit 2 -- F814W (02)	[==>1305.0 Secs (Pattern 1)]	[1]
									[==>1255.0 Secs (Pattern 2)]	
									[==>1352.0 Secs (Pattern 3)]	[2]
									[==>1352.0 Secs (Pattern 4)]	

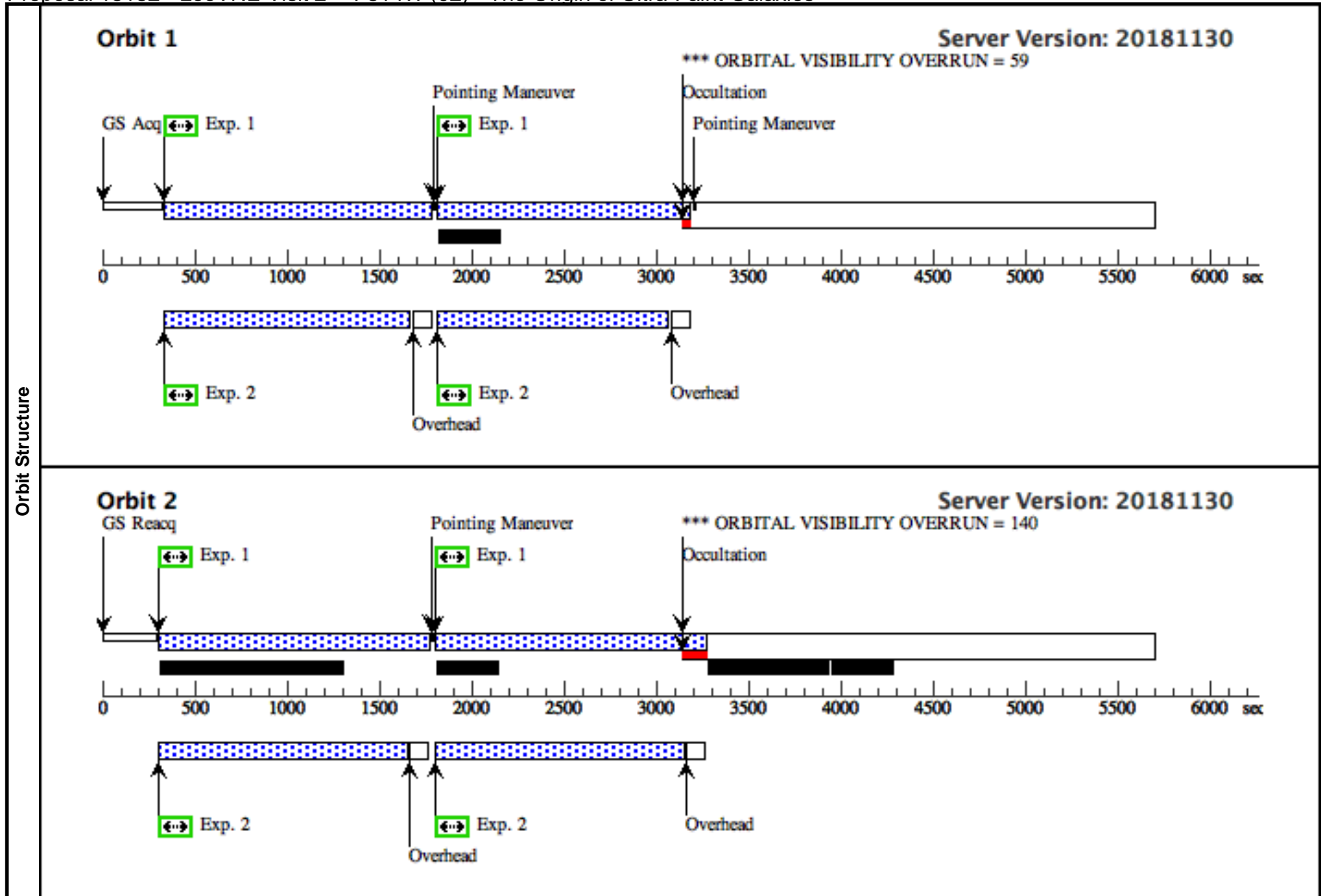

Proposal 15182 - Herceast Visit 1 -- F606W (03) - The Origin of Ultra-Faint Galaxies

Tue Apr 16 20:01:58 GMT 2019

Visit	<p>Proposal 15182, Herceast Visit 1 -- F606W (03), failed</p> <p>Diagnostic Status: Warning</p> <p>Scientific Instruments: WFC3/UVIS, ACS/WFC</p> <p>Special Requirements: ORIENT 260D TO 290 D</p> <p><i>Comments: We are splitting our 10 orbits of Herceast into 4 visits. The initial visit should have an ORIENT between 260 and 290 degrees. Coordinated parallels with WFC3 will be taken. The 2nd through 4th visits will have the same orientation as the initial visit.</i></p> <p><i>Visit 1 and Visit 3 for Herceast are 2-orbit visits, with a standard ACS-WFC-DITHER-BOX. Visit 2 and Visit 4 are 3-orbits, with a standard ACS-WFC-DITHER-BOX, and then a small-scale ACS-WFC-DITHER-LINE in the third orbit. This will ultimately give 5 orbits per filter, ten orbits total.</i></p>									
	<p>(Herceast Visit 1 -- F606W (03)) Warning (Orbit Planner): ORBITAL VISIBILITY OVERRUN</p> <p>(Herceast Visit 1 -- F606W (03)) Warning (Orbit Planner): ORBITAL VISIBILITY OVERRUN</p>									
Diagnosics										
Patterns	#	Primary Pattern	Secondary Pattern	Exposures						
	(1)	Pattern Type=ACS-WFC-DITHER-BOX Purpose=DITHER Number Of Points=4 Point Spacing=0.262 Line Spacing=0.192	Coordinate Frame=POS-TARG Pattern Orientation=18.39 Angle Between Sides=68.14 Center Pattern=false		(1-2)					
Fixed Targets	#	Name	Target Coordinates	Targ. Coord. Corrections	Fluxes	Miscellaneous				
	(1)	HERCEAST	RA: 16 31 43.0056 (247.9291900d) Dec: +12 43 43.82 (12.72884d) Equinox: J2000		V=14.6+/-0.2	Reference Frame: ICRS				
<p><i>Comments:</i> Category=GALAXY Description=[DWARF SPHEROIDAL]</p>										
Exposures	#	Label	Target	Config,Mode,Aperture	Spectral Els.	Opt. Params.	Special Reqs.	Groups	Exp. Time (Total)/[Actual Dur.]	Orbit
	1	(1) HERCEAST		ACS/WFC, ACCUM, WFC	F606W			Pattern 1, Exps 1-2 in Herceast Visit 1 -- F606W (03) (1)	1200.0 Secs (5188 Secs)	
								Prime + Parallel Group 1-2 in Pattern 1, Exps 1-2 in Herceast Visit 1 -- F606W (03)	[==>1249.0 Secs (Pattern 1)] [==>1249.0 Secs (Pattern 2)]	[1]
								Prime + Parallel Group 1-2 in Pattern 1, Exps 1-2 in Herceast Visit 1 -- F606W (03)	[==>1345.0 Secs (Pattern 3)] [==>1345.0 Secs (Pattern 4)]	[2]
2	(1) HERCEAST		WFC3/UVIS, ACCUM, UVIS	F606W				Pattern 1, Exps 1-2 in Herceast Visit 1 -- F606W (03) (1)	1200. Secs (5278 Secs)	
								Prime + Parallel Group 1-2 in Pattern 1, Exps 1-2 in Herceast Visit 1 -- F606W (03)	[==>1309.0 Secs (Pattern 1)] [==>1259.0 Secs (Pattern 2)]	[1]
								Prime + Parallel Group 1-2 in Pattern 1, Exps 1-2 in Herceast Visit 1 -- F606W (03)	[==>1355.0 Secs (Pattern 3)] [==>1355.0 Secs (Pattern 4)]	[2]

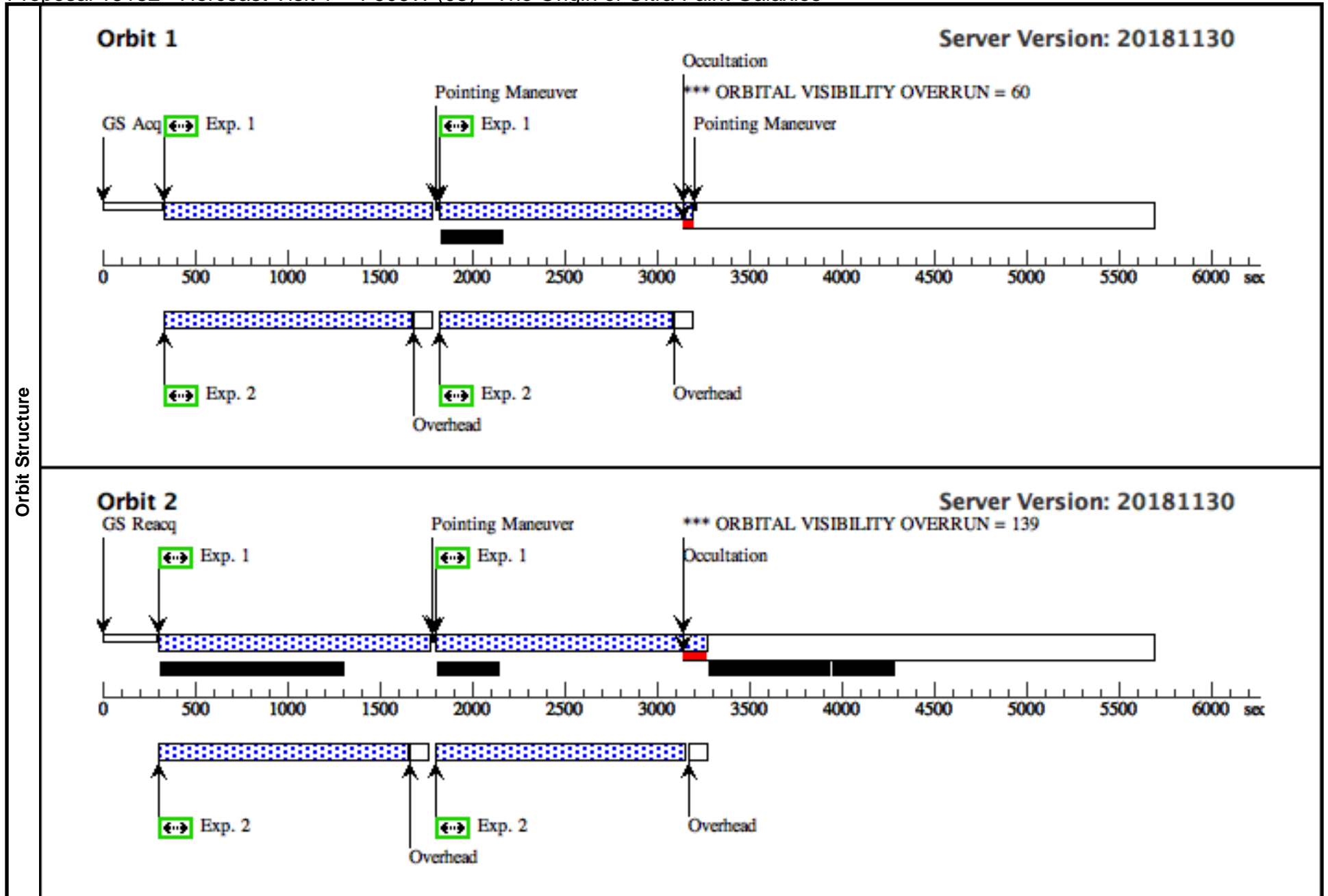

Proposal 15182 - Herceast Visit 1 -- F606W (53) - The Origin of Ultra-Faint Galaxies

Tue Apr 16 20:01:58 GMT 2019

Visit	<p>Proposal 15182, Herceast Visit 1 -- F606W (53), completed</p> <p>Diagnostic Status: No Diagnostics</p> <p>Scientific Instruments: WFC3/UVIS, ACS/WFC</p> <p>Special Requirements: SAME ORIENT AS 03</p> <p><i>Comments: We are splitting our 10 orbits of Herceast into 4 visits. The initial visit should have an ORIENT between 260 and 290 degrees. Coordinated parallels with WFC3 will be taken. The 2nd through 4th visits will have the same orientation as the initial visit.</i></p> <p><i>Visit 1 and Visit 3 for Herceast are 2-orbit visits, with a standard ACS-WFC-DITHER-BOX. Visit 2 and Visit 4 are 3-orbits, with a standard ACS-WFC-DITHER-BOX, and then a small-scale ACS-WFC-DITHER-LINE in the third orbit. This will ultimately give 5 orbits per filter, ten orbits total.</i></p> <p><i>This is a repeat of Visit 03. So it is connected to Visit 03 with a same orient as constraint, so the orient can be the same.</i></p>		
--------------	---	--	--

Patterns	#	Primary Pattern	Secondary Pattern	Exposures
	(1)	Pattern Type=ACS-WFC-DITHER-BOX Purpose=DITHER Number Of Points=4 Point Spacing=0.262 Line Spacing=0.192	Coordinate Frame=POS-TARG Pattern Orientation=18.39 Angle Between Sides=68.14 Center Pattern=false	(1-2)

Fixed Targets	#	Name	Target Coordinates	Targ. Coord. Corrections	Fluxes	Miscellaneous
	(1)	HERCEAST	RA: 16 31 43.0056 (247.9291900d) Dec: +12 43 43.82 (12.72884d) Equinox: J2000		V=14.6+/-0.2	Reference Frame: ICRS
	<p><i>Comments:</i> <i>Category=GALAXY</i> <i>Description=[DWARF SPHEROIDAL]</i></p>					

Exposures	#	Label	Target	Config,Mode,Aperture	Spectral Els.	Opt. Params.	Special Reqs.	Groups	Exp. Time (Total)/[Actual Dur.]	Orbit
	1	(1) HERCEAST	ACS/WFC, ACCUM, WFC	F606W				Pattern 1, Exps 1-2 in Herceast Visit 1 -- F606W (53) (1)	1200.0 Secs (4988 Secs)	
								Prime + Parallel Group 1-2 in Pattern 1, Exps 1-2 in Herceast Visit 1 -- F606W (53)	[==>1219.0 Secs (Pattern 1)]	[1]
	2	(1) HERCEAST	WFC3/UVIS, ACCUM, UVIS	F606W				Pattern 1, Exps 1-2 in Herceast Visit 1 -- F606W (53) (1)	[==>1219.0 Secs (Pattern 2)]	
								Prime + Parallel Group 1-2 in Pattern 1, Exps 1-2 in Herceast Visit 1 -- F606W (53)	[==>1275.0 Secs (Pattern 3)]	[2]
	2	(1) HERCEAST	WFC3/UVIS, ACCUM, UVIS	F606W				Pattern 1, Exps 1-2 in Herceast Visit 1 -- F606W (53) (1)	[==>1275.0 Secs (Pattern 4)]	
								Prime + Parallel Group 1-2 in Pattern 1, Exps 1-2 in Herceast Visit 1 -- F606W (53)	[==>1200.0 Secs (5078 Secs)]	[1]
								[==>1279.0 Secs (Pattern 1)]		
								[==>1229.0 Secs (Pattern 2)]		
								[==>1285.0 Secs (Pattern 3)]		
								[==>1285.0 Secs (Pattern 4)]		

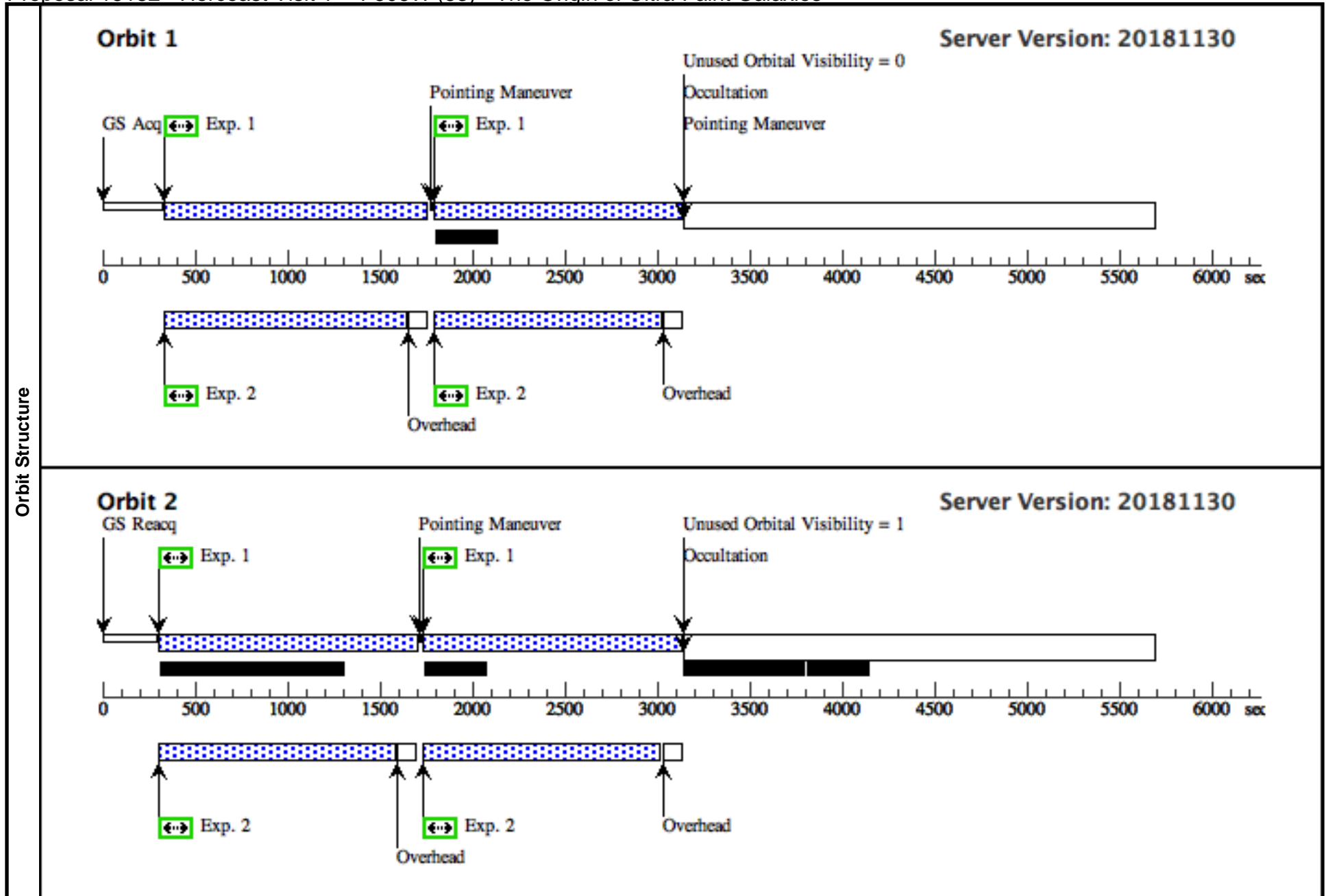

Proposal 15182 - Herceast Visit 2 -- F606W (54) - The Origin of Ultra-Faint Galaxies

Tue Apr 16 20:01:58 GMT 2019

Visit	<p>Proposal 15182, Herceast Visit 2 -- F606W (54), completed</p> <p>Diagnostic Status: No Diagnostics</p> <p>Scientific Instruments: WFC3/UVIS, ACS/WFC</p> <p>Special Requirements: SAME ORIENT AS 53</p> <p><i>Comments: We are splitting our 10 orbits of Herceast into 4 visits. The initial visit should have an ORIENT between 260 and 290 degrees. Coordinated parallels with WFC3 will be taken. The 2nd through 4th visits will have the same orientation as the initial visit.</i></p> <p><i>Visit 1 and Visit 3 for Herceast are 2-orbit visits, with a standard ACS-WFC-DITHER-BOX. Visit 2 and Visit 4 are 3-orbits, with a standard ACS-WFC-DITHER-BOX, and then a small-scale ACS-WFC-DITHER-LINE in the third orbit. This will ultimately give 5 orbits per filter, ten orbits total.</i></p> <p><i>This is a repeat of Visit 04.</i></p>					
Patterns	#	Primary Pattern	Secondary Pattern	Exposures		
	(1)	Pattern Type=ACS-WFC-DITHER-BOX Purpose=DITHER Number Of Points=4 Point Spacing=0.262 Line Spacing=0.192	Coordinate Frame=POS-TARG Pattern Orientation=18.39 Angle Between Sides=68.14 Center Pattern=false		(1-2)	
(2)	Pattern Type=ACS-WFC-DITHER-LINE Purpose=DITHER Number Of Points=2 Point Spacing=0.149 Line Spacing=	Coordinate Frame=POS-TARG Pattern Orientation=34.29 Angle Between Sides= Center Pattern=false		(3-4)		
Fixed Targets	#	Name	Target Coordinates	Targ. Coord. Corrections	Fluxes	Miscellaneous
	(1)	HERCEAST	RA: 16 31 43.0056 (247.9291900d) Dec: +12 43 43.82 (12.72884d) Equinox: J2000		V=14.6+/-0.2	Reference Frame: ICRS
<p><i>Comments:</i> <i>Category=GALAXY</i> <i>Description=[DWARF SPHEROIDAL]</i></p>						

Proposal 15182 - Herceast Visit 2 -- F606W (54) - The Origin of Ultra-Faint Galaxies

Exposures	#	Label	Target	Config,Mode,Aperture	Spectral Els.	Opt. Params.	Special Reqs.	Groups	Exp. Time (Total)/[Actual Dur.]	Orbit
	1		(1) HERCEAST	ACS/WFC, ACCUM, WFC	F606W			Pattern 1, Exps 1-2 in Herceast Visit 2 -- F606W (54) (1)	1200.0 Secs (4988 Secs)	
								Prime + Parallel Group 1-2 in Pattern 1, Exps 1-2 in Herceast Visit 2 -- F606W (54)	[==>1219.0 Secs (Pattern 1)] [==>1219.0 Secs (Pattern 2)]	[1]
									[==>1275.0 Secs (Pattern 3)] [==>1275.0 Secs (Pattern 4)]	[2]
2		(1) HERCEAST	WFC3/UVIS, ACCUM, UVIS	F606W			Pattern 1, Exps 1-2 in Herceast Visit 2 -- F606W (54) (1)	1200. Secs (5078 Secs)		
							Prime + Parallel Group 1-2 in Pattern 1, Exps 1-2 in Herceast Visit 2 -- F606W (54)	[==>1279.0 Secs (Pattern 1)] [==>1229.0 Secs (Pattern 2)]	[1]	
								[==>1285.0 Secs (Pattern 3)] [==>1285.0 Secs (Pattern 4)]	[2]	
3		(1) HERCEAST	ACS/WFC, ACCUM, WFC	F606W			Pattern 2, Exps 3-4 in Herceast Visit 2 -- F606W (54) (2)	1150.0 Secs (2550 Secs)		
							Prime + Parallel Group 3-4 in Pattern 2, Exps 3-4 in Herceast Visit 2 -- F606W (54)	[==>1275.0 Secs (Pattern 1)] [==>1275.0 Secs (Pattern 2)]	[3]	
4		(1) HERCEAST	WFC3/UVIS, ACCUM, UVIS	F606W			Pattern 2, Exps 3-4 in Herceast Visit 2 -- F606W (54) (2)	1150. Secs (2570 Secs)		
							Prime + Parallel Group 3-4 in Pattern 2, Exps 3-4 in Herceast Visit 2 -- F606W (54)	[==>1285.0 Secs (Pattern 1)] [==>1285.0 Secs (Pattern 2)]	[3]	

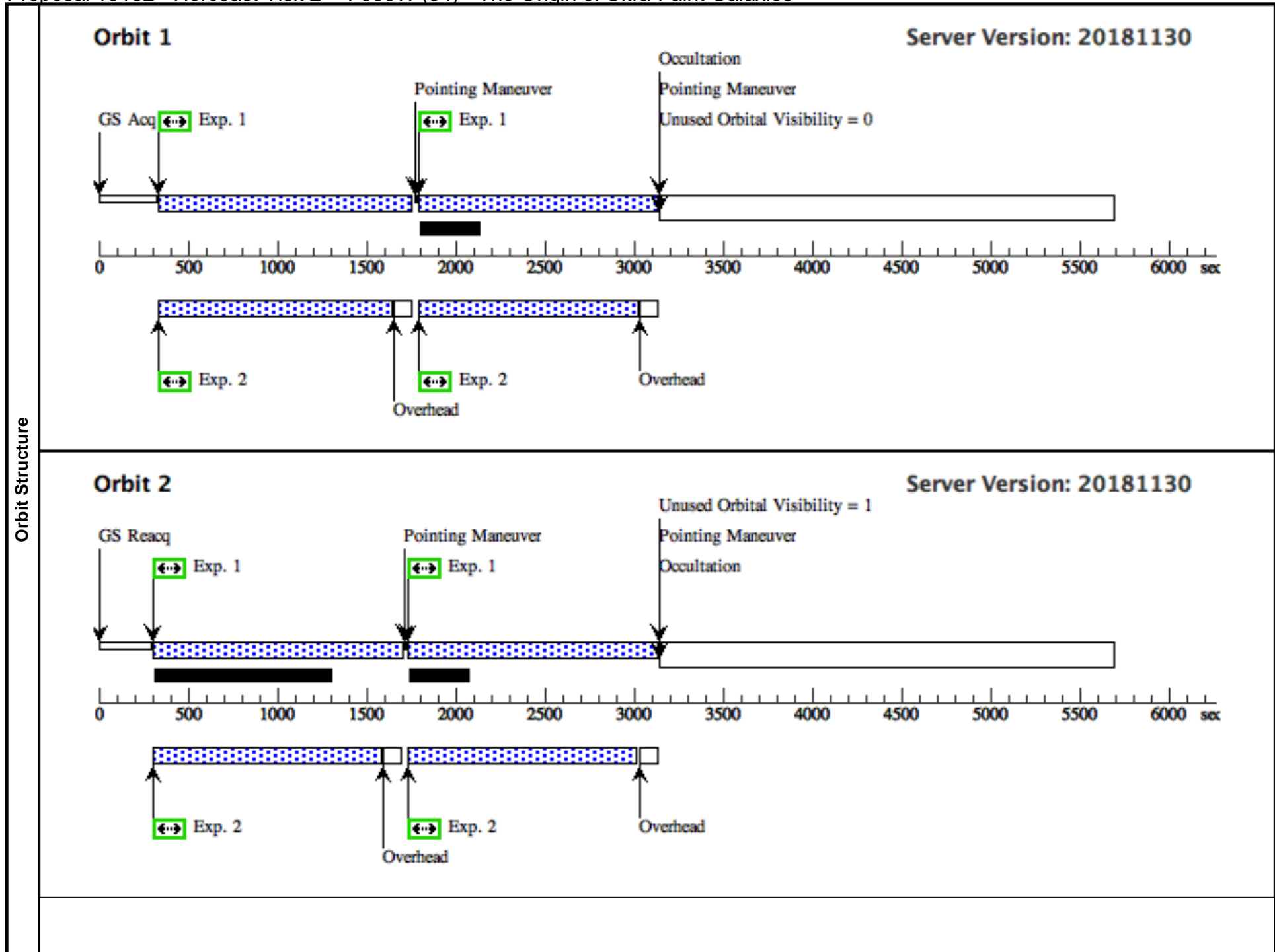

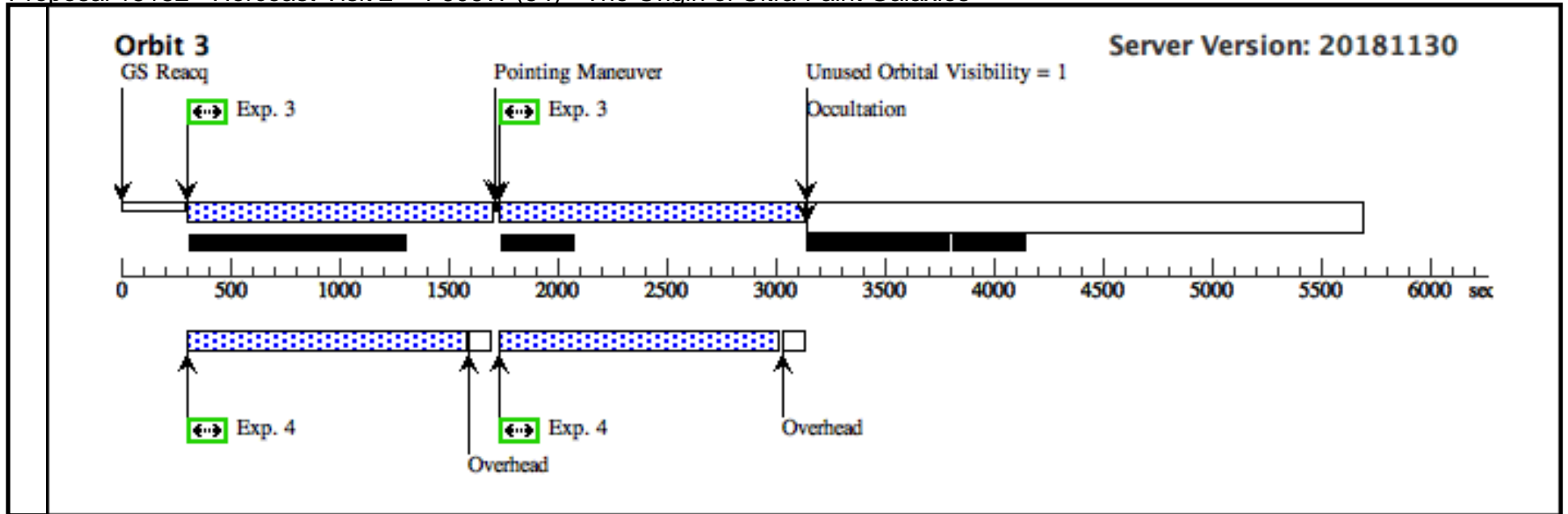

Proposal 15182 - Herceast Visit 4 -- F814W (56) - The Origin of Ultra-Faint Galaxies

Tue Apr 16 20:01:58 GMT 2019

Visit	<p>Proposal 15182, Herceast Visit 4 -- F814W (56), failed</p> <p>Diagnostic Status: No Diagnostics</p> <p>Scientific Instruments: WFC3/UVIS, ACS/WFC</p> <p>Special Requirements: SAME ORIENT AS 53</p> <p><i>Comments: We are splitting our 10 orbits of Herceast into 4 visits. The initial visit should have an ORIENT between 260 and 290 degrees. Coordinated parallels with WFC3 will be taken. The 2nd through 4th visits will have the same orientation as the initial visit.</i></p> <p><i>Visit 1 and Visit 3 for Herceast are 2-orbit visits, with a standard ACS-WFC-DITHER-BOX. Visit 2 and Visit 4 are 3-orbits, with a standard ACS-WFC-DITHER-BOX, and then a small-scale ACS-WFC-DITHER-LINE in the third orbit. This will ultimately give 5 orbits per filter, ten orbits total.</i></p> <p><i>This is a repeat of Visit 06.</i></p>					
Patterns	#	Primary Pattern	Secondary Pattern	Exposures		
	(1)	Pattern Type=ACS-WFC-DITHER-BOX Purpose=DITHER Number Of Points=4 Point Spacing=0.262 Line Spacing=0.192	Coordinate Frame=POS-TARG Pattern Orientation=18.39 Angle Between Sides=68.14 Center Pattern=false		(1-2)	
(2)	Pattern Type=ACS-WFC-DITHER-LINE Purpose=DITHER Number Of Points=2 Point Spacing=0.149 Line Spacing=	Coordinate Frame=POS-TARG Pattern Orientation=34.29 Angle Between Sides= Center Pattern=false		(3-4)		
Fixed Targets	#	Name	Target Coordinates	Targ. Coord. Corrections	Fluxes	Miscellaneous
	(1)	HERCEAST	RA: 16 31 43.0056 (247.9291900d) Dec: +12 43 43.82 (12.72884d) Equinox: J2000		V=14.6+/-0.2	Reference Frame: ICRS
<p><i>Comments:</i> <i>Category=GALAXY</i> <i>Description=[DWARF SPHEROIDAL]</i></p>						

Proposal 15182 - Herceast Visit 4 -- F814W (56) - The Origin of Ultra-Faint Galaxies

Exposures	#	Label	Target	Config,Mode,Aperture	Spectral Els.	Opt. Params.	Special Reqs.	Groups	Exp. Time (Total)/[Actual Dur.]	Orbit
	1		(1) HERCEAST	ACS/WFC, ACCUM, WFC	F814W			Pattern 1, Exps 1-2 in Herceast Visit 4 -- F814W (56) (1)	1200.0 Secs (4988 Secs)	
								Prime + Parallel Group 1-2 in Pattern 1, Exps 1-2 in Herceast Visit 4 -- F814W (56)	[==>1219.0 Secs (Pattern 1)] [==>1219.0 Secs (Pattern 2)]	[1]
									[==>1275.0 Secs (Pattern 3)] [==>1275.0 Secs (Pattern 4)]	[2]
2		(1) HERCEAST	WFC3/UVIS, ACCUM, UVIS	F814W			Pattern 1, Exps 1-2 in Herceast Visit 4 -- F814W (56) (1)	1200. Secs (5078 Secs)		
							Prime + Parallel Group 1-2 in Pattern 1, Exps 1-2 in Herceast Visit 4 -- F814W (56)	[==>1279.0 Secs (Pattern 1)] [==>1229.0 Secs (Pattern 2)]	[1]	
								[==>1285.0 Secs (Pattern 3)] [==>1285.0 Secs (Pattern 4)]	[2]	
3		(1) HERCEAST	ACS/WFC, ACCUM, WFC	F814W			Pattern 2, Exps 3-4 in Herceast Visit 4 -- F814W (56) (2)	1150.0 Secs (2550 Secs)		
							Prime + Parallel Group 3-4 in Pattern 2, Exps 3-4 in Herceast Visit 4 -- F814W (56)	[==>1275.0 Secs (Pattern 1)] [==>1275.0 Secs (Pattern 2)]	[3]	
4		(1) HERCEAST	WFC3/UVIS, ACCUM, UVIS	F814W			Pattern 2, Exps 3-4 in Herceast Visit 4 -- F814W (56) (2)	1150. Secs (2570 Secs)		
							Prime + Parallel Group 3-4 in Pattern 2, Exps 3-4 in Herceast Visit 4 -- F814W (56)	[==>1285.0 Secs (Pattern 1)] [==>1285.0 Secs (Pattern 2)]	[3]	

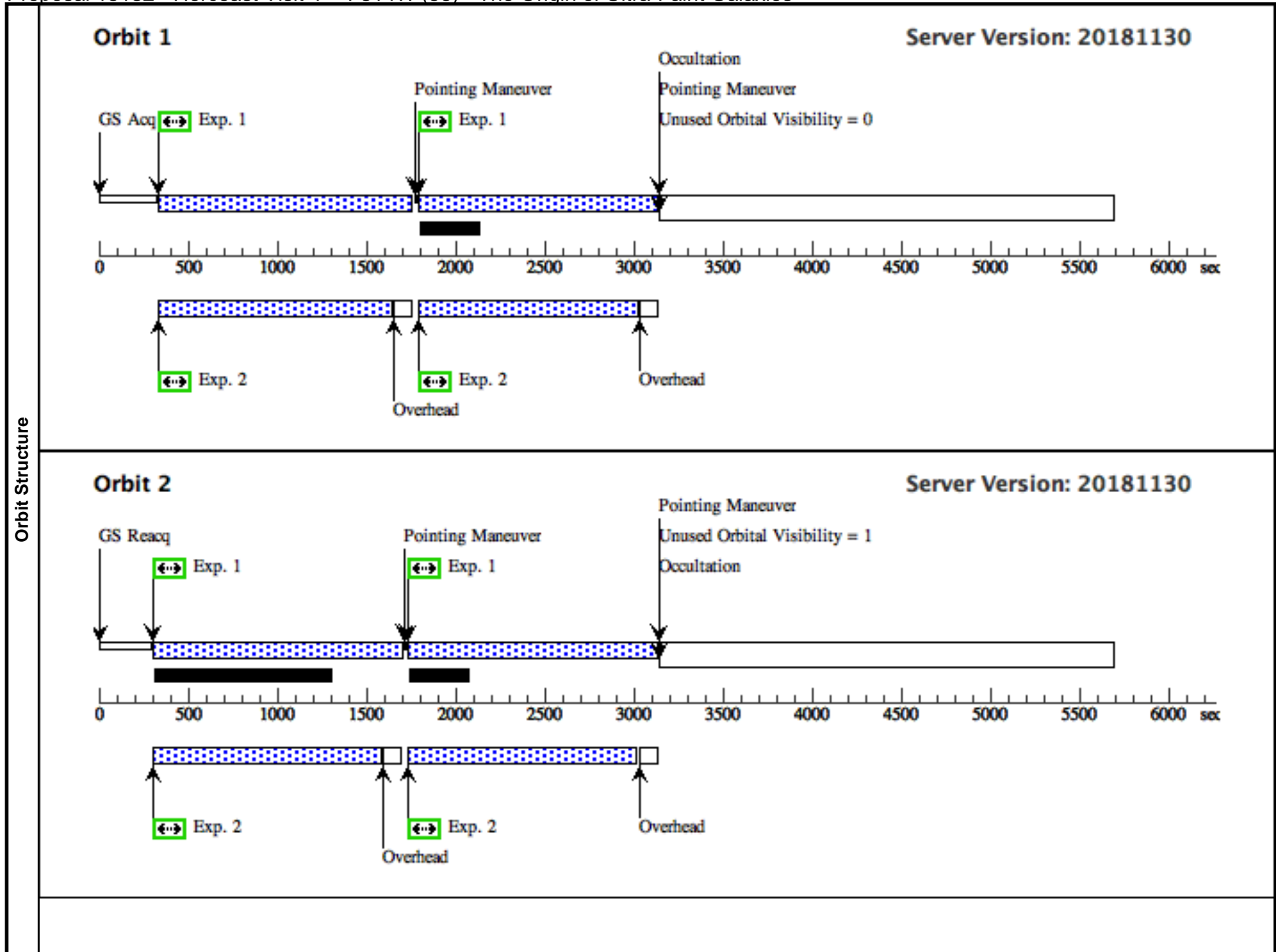

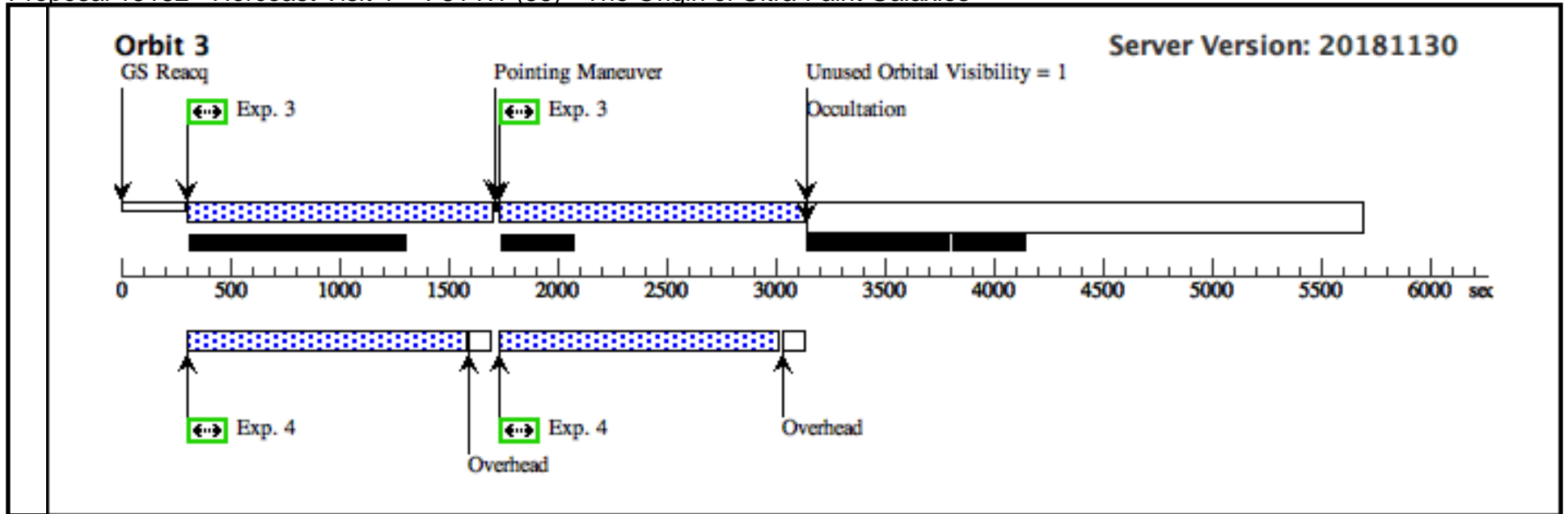

Proposal 15182 - Herceast Visit 2 -- F606W (04) - The Origin of Ultra-Faint Galaxies

Tue Apr 16 20:01:58 GMT 2019

Visit	<p>Proposal 15182, Herceast Visit 2 -- F606W (04), failed</p> <p>Diagnostic Status: Warning</p> <p>Scientific Instruments: WFC3/UVIS, ACS/WFC</p> <p>Special Requirements: SAME ORIENT AS 03</p> <p><i>Comments: We are splitting our 10 orbits of Herceast into 4 visits. The initial visit should have an ORIENT between 260 and 290 degrees. Coordinated parallels with WFC3 will be taken. The 2nd through 4th visits will have the same orientation as the initial visit.</i></p> <p><i>Visit 1 and Visit 3 for Herceast are 2-orbit visits, with a standard ACS-WFC-DITHER-BOX. Visit 2 and Visit 4 are 3-orbits, with a standard ACS-WFC-DITHER-BOX, and then a small-scale ACS-WFC-DITHER-LINE in the third orbit. This will ultimately give 5 orbits per filter, ten orbits total.</i></p>					
	<p>(Herceast Visit 2 -- F606W (04)) Warning (Orbit Planner): ORBITAL VISIBILITY OVERRUN</p> <p>(Herceast Visit 2 -- F606W (04)) Warning (Orbit Planner): ORBITAL VISIBILITY OVERRUN</p> <p>(Herceast Visit 2 -- F606W (04)) Warning (Orbit Planner): ORBITAL VISIBILITY OVERRUN</p>					
Diagnosics						
Patterns	#	Primary Pattern	Secondary Pattern	Exposures		
	(1)	Pattern Type=ACS-WFC-DITHER-BOX Purpose=DITHER Number Of Points=4 Point Spacing=0.262 Line Spacing=0.192	Coordinate Frame=POS-TARG Pattern Orientation=18.39 Angle Between Sides=68.14 Center Pattern=false		(1-2)	
	(2)	Pattern Type=ACS-WFC-DITHER-LINE Purpose=DITHER Number Of Points=2 Point Spacing=0.149 Line Spacing=	Coordinate Frame=POS-TARG Pattern Orientation=34.29 Angle Between Sides= Center Pattern=false		(3-4)	
Fixed Targets	#	Name	Target Coordinates	Targ. Coord. Corrections	Fluxes	Miscellaneous
	(1)	HERCEAST	RA: 16 31 43.0056 (247.9291900d) Dec: +12 43 43.82 (12.72884d) Equinox: J2000		V=14.6+/-0.2	Reference Frame: ICRS
<p><i>Comments:</i> <i>Category=GALAXY</i> <i>Description=[DWARF SPHEROIDAL]</i></p>						

Proposal 15182 - Herceast Visit 2 -- F606W (04) - The Origin of Ultra-Faint Galaxies

Exposures	#	Label	Target	Config,Mode,Aperture	Spectral Els.	Opt. Params.	Special Reqs.	Groups	Exp. Time (Total)/[Actual Dur.]	Orbit
	1		(1) HERCEAST	ACS/WFC, ACCUM, WFC	F606W			Pattern 1, Exps 1-2 in Herceast Visit 2 -- F606W (04) (1)	1200.0 Secs (5188 Secs)	
								Prime + Parallel Group 1-2 in Pattern 1, Exps 1-2 in Herceast Visit 2 -- F606W (04)	[==>1249.0 Secs (Pattern 1)] [==>1249.0 Secs (Pattern 2)]	[1]
									[==>1345.0 Secs (Pattern 3)] [==>1345.0 Secs (Pattern 4)]	[2]
2		(1) HERCEAST	WFC3/UVIS, ACCUM, UVIS	F606W			Pattern 1, Exps 1-2 in Herceast Visit 2 -- F606W (04) (1)	1200. Secs (5278 Secs)		
							Prime + Parallel Group 1-2 in Pattern 1, Exps 1-2 in Herceast Visit 2 -- F606W (04)	[==>1309.0 Secs (Pattern 1)] [==>1259.0 Secs (Pattern 2)]	[1]	
								[==>1355.0 Secs (Pattern 3)] [==>1355.0 Secs (Pattern 4)]	[2]	
3		(1) HERCEAST	ACS/WFC, ACCUM, WFC	F606W			Pattern 2, Exps 3-4 in Herceast Visit 2 -- F606W (04) (2)	1150.0 Secs (2686 Secs)		
							Prime + Parallel Group 3-4 in Pattern 2, Exps 3-4 in Herceast Visit 2 -- F606W (04)	[==>1343.0 Secs (Pattern 1)] [==>1343.0 Secs (Pattern 2)]	[3]	
4		(1) HERCEAST	WFC3/UVIS, ACCUM, UVIS	F606W			Pattern 2, Exps 3-4 in Herceast Visit 2 -- F606W (04) (2)	1150. Secs (2706 Secs)		
							Prime + Parallel Group 3-4 in Pattern 2, Exps 3-4 in Herceast Visit 2 -- F606W (04)	[==>1353.0 Secs (Pattern 1)] [==>1353.0 Secs (Pattern 2)]	[3]	

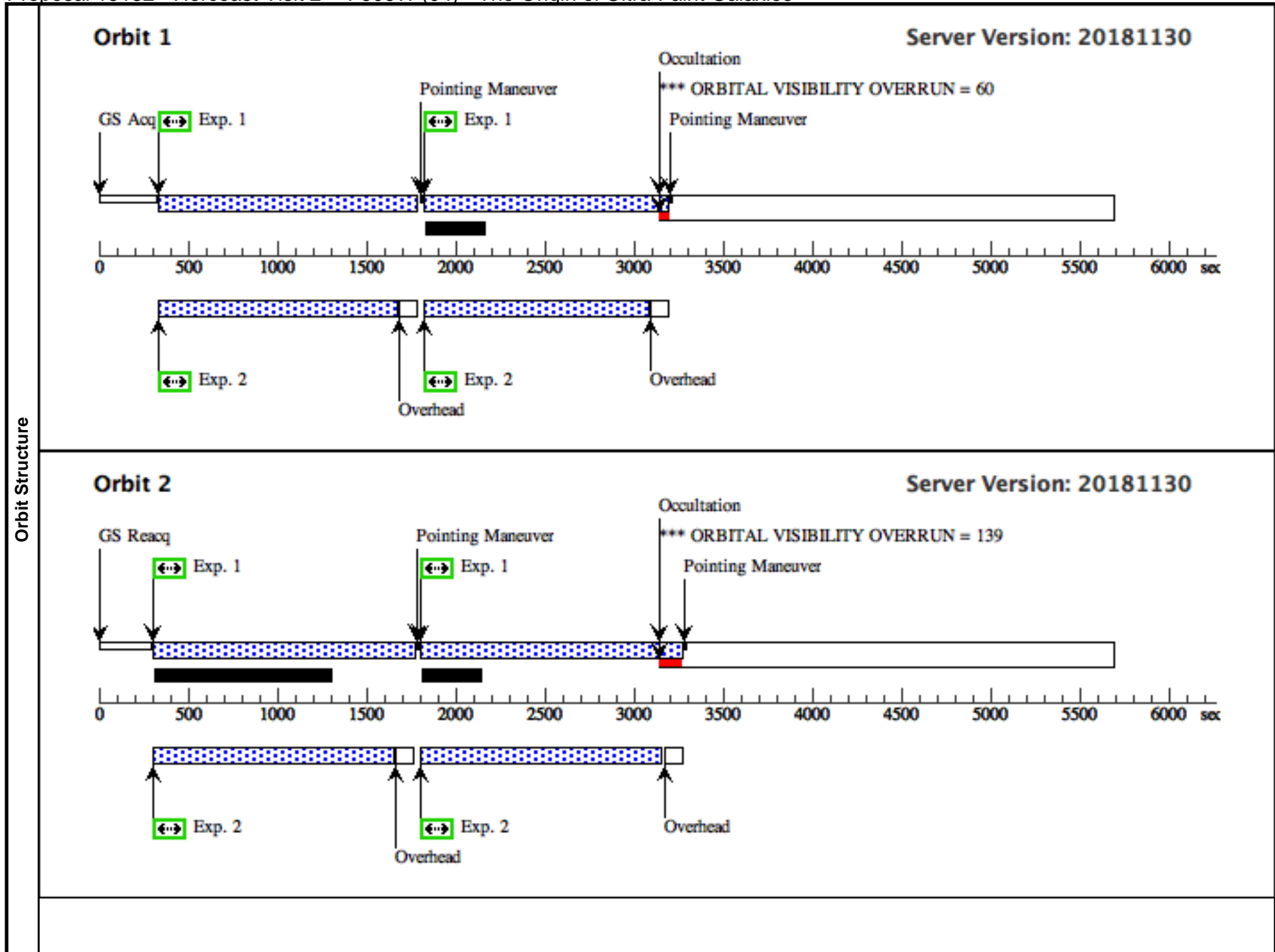

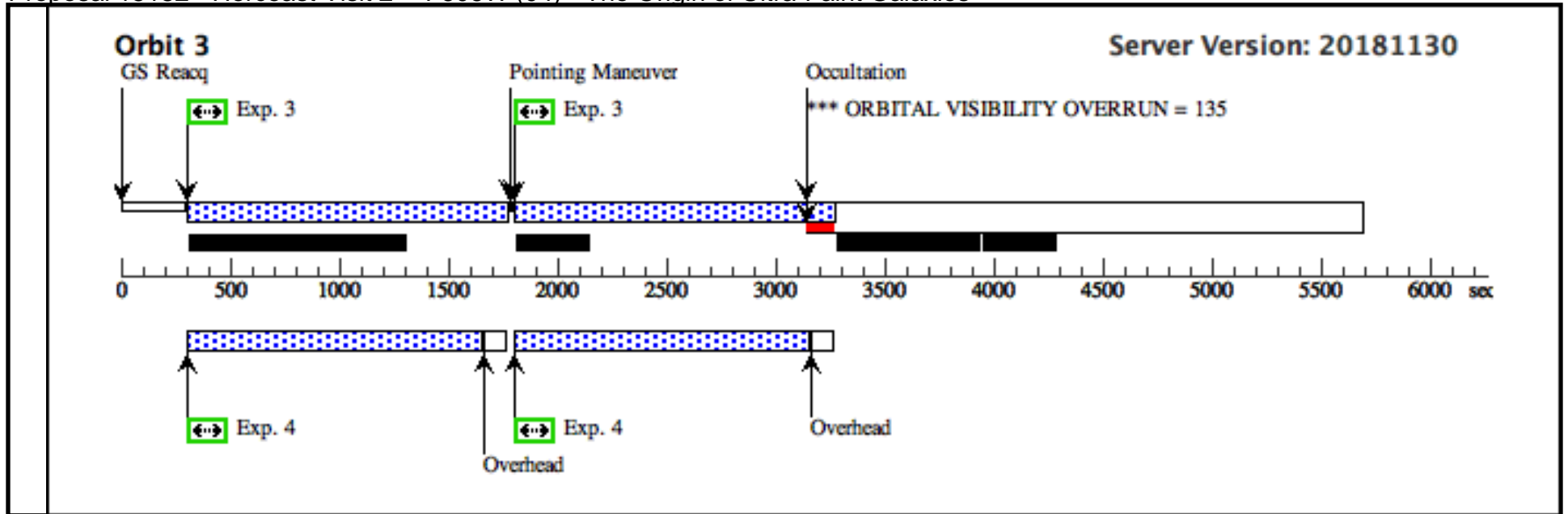

Proposal 15182 - Herceast Visit 3 -- F814W (05) - The Origin of Ultra-Faint Galaxies

Tue Apr 16 20:01:59 GMT 2019

Visit	<p>Proposal 15182, Herceast Visit 3 -- F814W (05), completed</p> <p>Diagnostic Status: Warning</p> <p>Scientific Instruments: WFC3/UVIS, ACS/WFC</p> <p>Special Requirements: SAME ORIENT AS 03</p> <p><i>Comments: We are splitting our 10 orbits of Herceast into 4 visits. The initial visit should have an ORIENT between 260 and 290 degrees. Coordinated parallels with WFC3 will be taken. The 2nd through 4th visits will have the same orientation as the initial visit.</i></p> <p><i>Visit 1 and Visit 3 for Herceast are 2-orbit visits, with a standard ACS-WFC-DITHER-BOX. Visit 2 and Visit 4 are 3-orbits, with a standard ACS-WFC-DITHER-BOX, and then a small-scale ACS-WFC-DITHER-LINE in the third orbit. This will ultimately give 5 orbits per filter, ten orbits total.</i></p>									
	<p>(Herceast Visit 3 -- F814W (05)) Warning (Orbit Planner): ORBITAL VISIBILITY OVERRUN</p> <p>(Herceast Visit 3 -- F814W (05)) Warning (Orbit Planner): ORBITAL VISIBILITY OVERRUN</p>									
Diagnosics										
Patterns	#	Primary Pattern	Secondary Pattern	Exposures						
	(1)	Pattern Type=ACS-WFC-DITHER-BOX Purpose=DITHER Number Of Points=4 Point Spacing=0.262 Line Spacing=0.192	Coordinate Frame=POS-TARG Pattern Orientation=18.39 Angle Between Sides=68.14 Center Pattern=false		(1-2)					
Fixed Targets	#	Name	Target Coordinates	Targ. Coord. Corrections	Fluxes	Miscellaneous				
	(1)	HERCEAST	RA: 16 31 43.0056 (247.9291900d) Dec: +12 43 43.82 (12.72884d) Equinox: J2000		V=14.6+/-0.2	Reference Frame: ICRS				
<p><i>Comments:</i> Category=GALAXY Description=[DWARF SPHEROIDAL]</p>										
Exposures	#	Label	Target	Config,Mode,Aperture	Spectral Els.	Opt. Params.	Special Reqs.	Groups	Exp. Time (Total)/[Actual Dur.]	Orbit
	1	(1) HERCEAST		ACS/WFC, ACCUM, WFC	F814W			Pattern 1, Exps 1-2 in Herceast Visit 3 -- F814W (05) (1)	1200.0 Secs (5188 Secs)	
								Prime + Parallel Group 1-2 in Pattern 1, Exps 1-2 in Herceast Visit 3 -- F814W (05)	[==>1249.0 Secs (Pattern 1)] [==>1249.0 Secs (Pattern 2)]	[1]
									[==>1345.0 Secs (Pattern 3)] [==>1345.0 Secs (Pattern 4)]	[2]
2	(1) HERCEAST		WFC3/UVIS, ACCUM, UVIS	F814W				Pattern 1, Exps 1-2 in Herceast Visit 3 -- F814W (05) (1)	1200. Secs (5278 Secs)	
								Prime + Parallel Group 1-2 in Pattern 1, Exps 1-2 in Herceast Visit 3 -- F814W (05)	[==>1309.0 Secs (Pattern 1)] [==>1259.0 Secs (Pattern 2)]	[1]
									[==>1355.0 Secs (Pattern 3)] [==>1355.0 Secs (Pattern 4)]	[2]

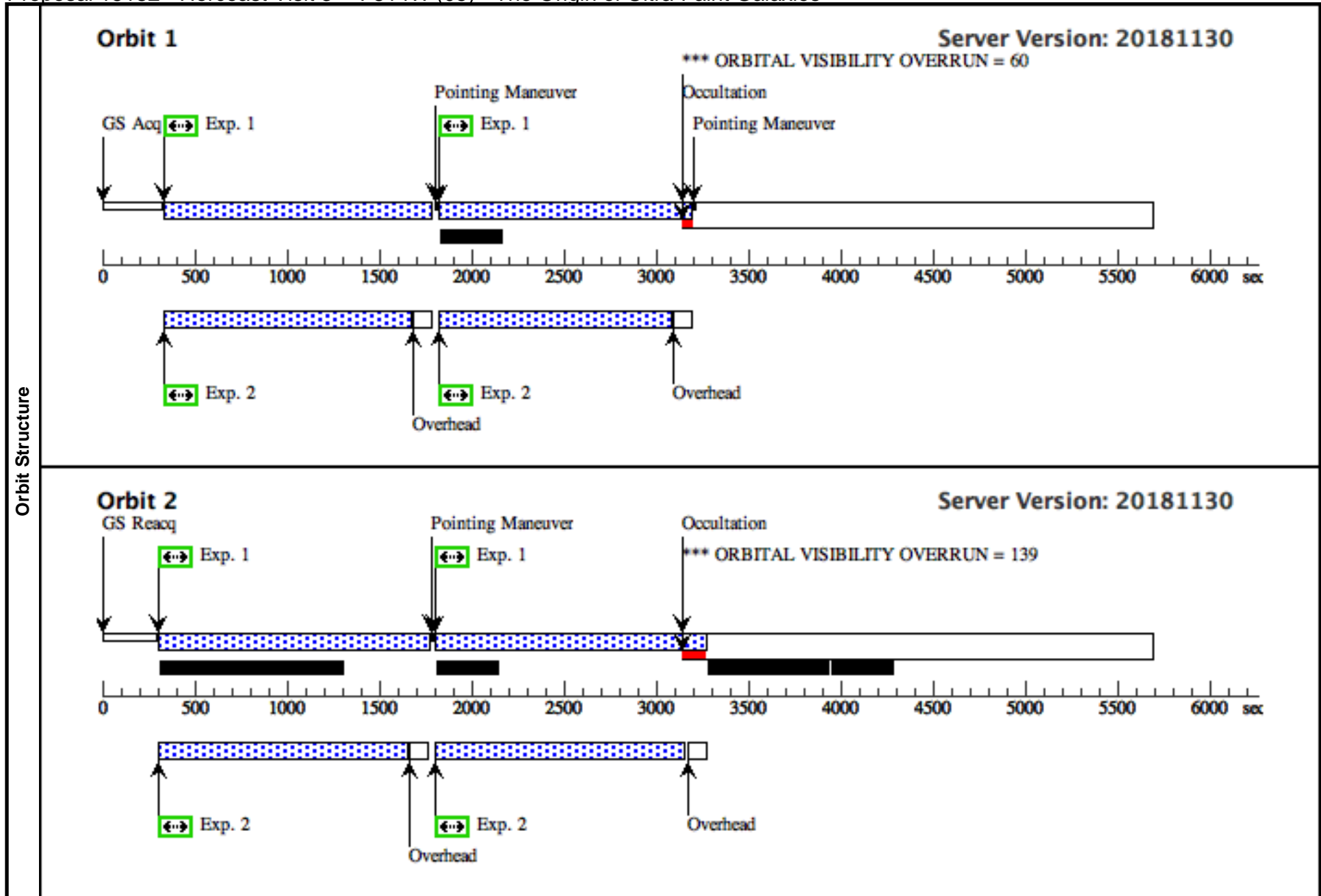

Proposal 15182 - Herceast Visit 4 -- F814W (06) - The Origin of Ultra-Faint Galaxies

Tue Apr 16 20:01:59 GMT 2019

Visit	<p>Proposal 15182, Herceast Visit 4 -- F814W (06), failed</p> <p>Diagnostic Status: Warning</p> <p>Scientific Instruments: WFC3/UVIS, ACS/WFC</p> <p>Special Requirements: ORIENT 266D TO 266 D</p> <p><i>Comments: We are splitting our 10 orbits of Herceast into 4 visits. The initial visit should have an ORIENT between 260 and 290 degrees. Coordinated parallels with WFC3 will be taken. The 2nd through 4th visits will have the same orientation as the initial visit.</i></p> <p><i>Visit 1 and Visit 3 for Herceast are 2-orbit visits, with a standard ACS-WFC-DITHER-BOX. Visit 2 and Visit 4 are 3-orbits, with a standard ACS-WFC-DITHER-BOX, and then a small-scale ACS-WFC-DITHER-LINE in the third orbit. This will ultimately give 5 orbits per filter, ten orbits total.</i></p>					
	<p>(Herceast Visit 4 -- F814W (06)) Warning (Orbit Planner): ORBITAL VISIBILITY OVERRUN</p> <p>(Herceast Visit 4 -- F814W (06)) Warning (Orbit Planner): ORBITAL VISIBILITY OVERRUN</p> <p>(Herceast Visit 4 -- F814W (06)) Warning (Orbit Planner): ORBITAL VISIBILITY OVERRUN</p>					
Diagnosics						
Patterns	#	Primary Pattern	Secondary Pattern	Exposures		
	(1)	Pattern Type=ACS-WFC-DITHER-BOX Purpose=DITHER Number Of Points=4 Point Spacing=0.262 Line Spacing=0.192	Coordinate Frame=POS-TARG Pattern Orientation=18.39 Angle Between Sides=68.14 Center Pattern=false		(1-2)	
	(2)	Pattern Type=ACS-WFC-DITHER-LINE Purpose=DITHER Number Of Points=2 Point Spacing=0.149 Line Spacing=	Coordinate Frame=POS-TARG Pattern Orientation=34.29 Angle Between Sides= Center Pattern=false		(3-4)	
Fixed Targets	#	Name	Target Coordinates	Targ. Coord. Corrections	Fluxes	Miscellaneous
	(1)	HERCEAST	RA: 16 31 43.0056 (247.9291900d) Dec: +12 43 43.82 (12.72884d) Equinox: J2000		V=14.6+/-0.2	Reference Frame: ICRS
<p><i>Comments:</i> <i>Category=GALAXY</i> <i>Description=[DWARF SPHEROIDAL]</i></p>						

Proposal 15182 - Herceast Visit 4 -- F814W (06) - The Origin of Ultra-Faint Galaxies

Exposures	#	Label	Target	Config,Mode,Aperture	Spectral Els.	Opt. Params.	Special Reqs.	Groups	Exp. Time (Total)/[Actual Dur.]	Orbit
	1		(1) HERCEAST	ACS/WFC, ACCUM, WFC	F814W			Pattern 1, Exps 1-2 in Herceast Visit 4 -- F814W (06) (1)	1200.0 Secs (5188 Secs)	
								Prime + Parallel Group 1-2 in Pattern 1, Exps 1-2 in Herceast Visit 4 -- F814W (06)	[==>1249.0 Secs (Pattern 1)] [==>1249.0 Secs (Pattern 2)]	[1]
									[==>1345.0 Secs (Pattern 3)] [==>1345.0 Secs (Pattern 4)]	[2]
2		(1) HERCEAST	WFC3/UVIS, ACCUM, UVIS	F814W			Pattern 1, Exps 1-2 in Herceast Visit 4 -- F814W (06) (1)	1200. Secs (5278 Secs)		
							Prime + Parallel Group 1-2 in Pattern 1, Exps 1-2 in Herceast Visit 4 -- F814W (06)	[==>1309.0 Secs (Pattern 1)] [==>1259.0 Secs (Pattern 2)]	[1]	
								[==>1355.0 Secs (Pattern 3)] [==>1355.0 Secs (Pattern 4)]	[2]	
3		(1) HERCEAST	ACS/WFC, ACCUM, WFC	F814W			Pattern 2, Exps 3-4 in Herceast Visit 4 -- F814W (06) (2)	1150.0 Secs (2686 Secs)		
							Prime + Parallel Group 3-4 in Pattern 2, Exps 3-4 in Herceast Visit 4 -- F814W (06)	[==>1343.0 Secs (Pattern 1)] [==>1343.0 Secs (Pattern 2)]	[3]	
4		(1) HERCEAST	WFC3/UVIS, ACCUM, UVIS	F814W			Pattern 2, Exps 3-4 in Herceast Visit 4 -- F814W (06) (2)	1150. Secs (2706 Secs)		
							Prime + Parallel Group 3-4 in Pattern 2, Exps 3-4 in Herceast Visit 4 -- F814W (06)	[==>1353.0 Secs (Pattern 1)] [==>1353.0 Secs (Pattern 2)]	[3]	

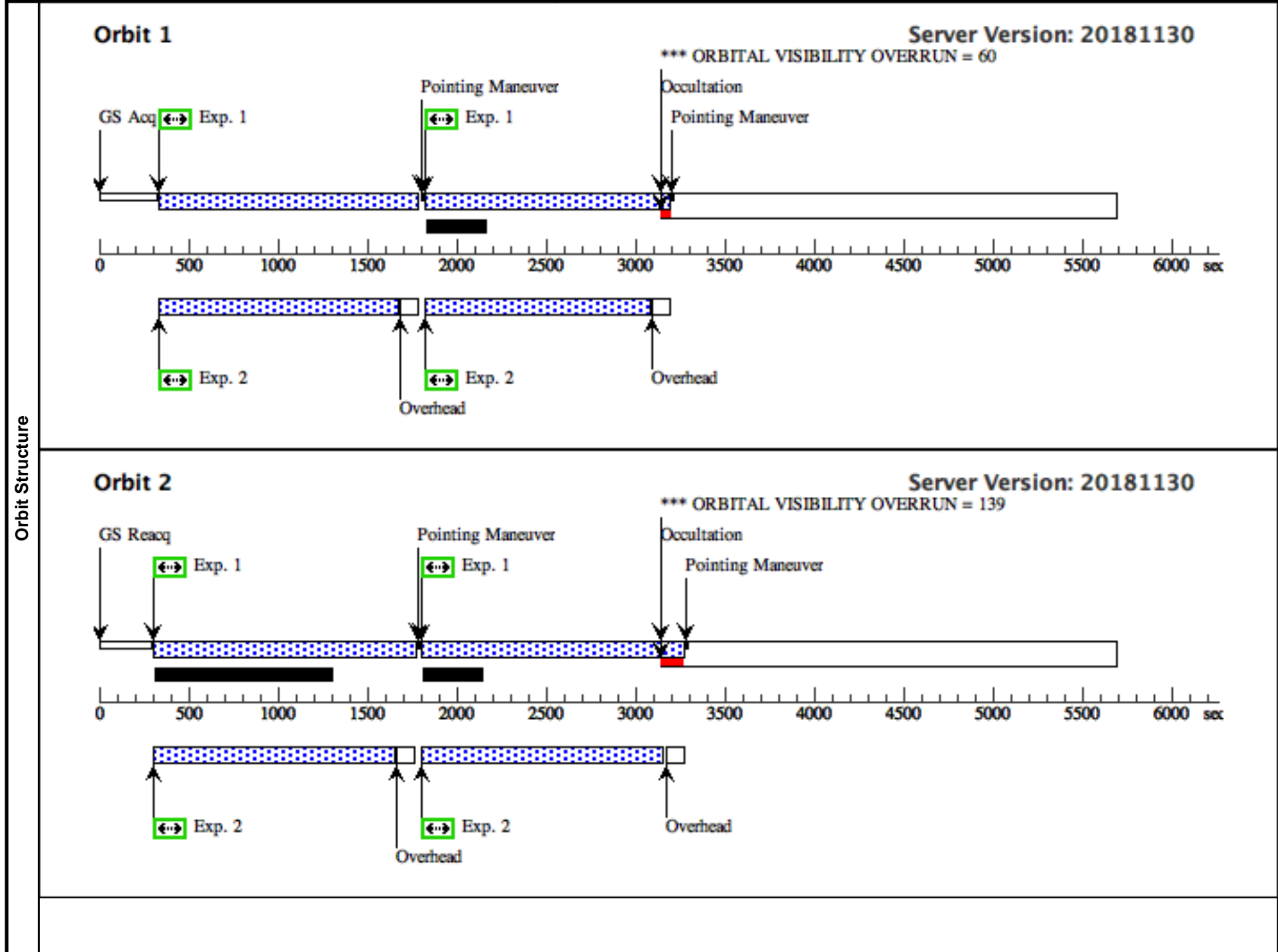

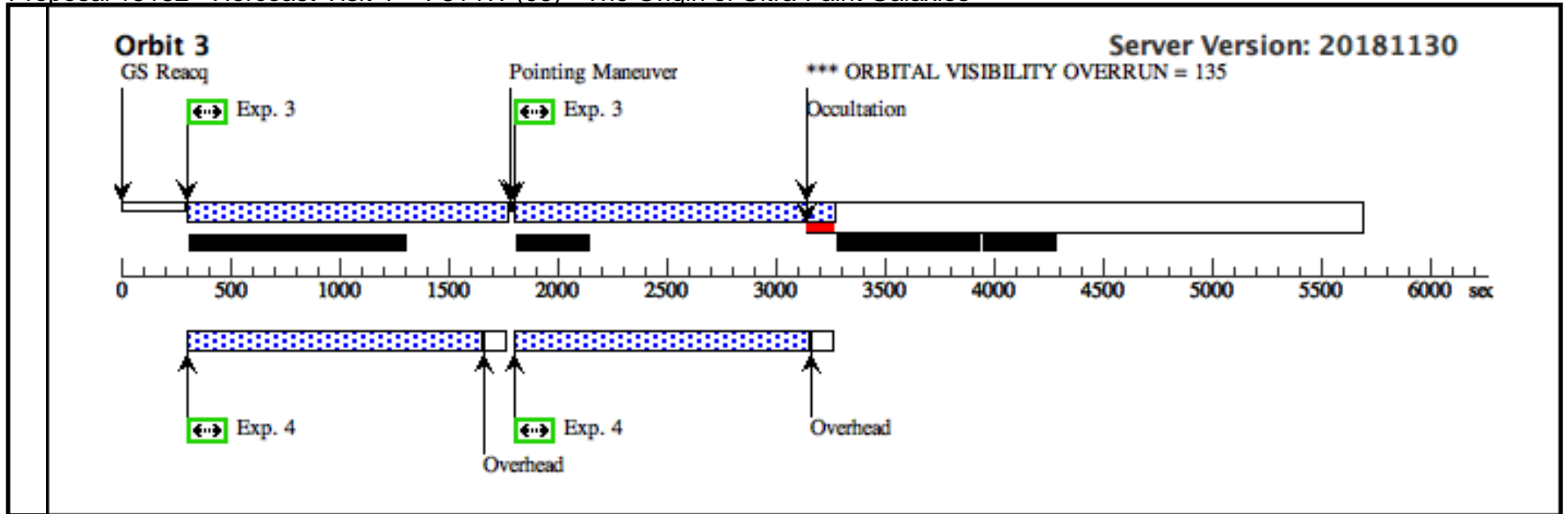

Proposal 15182 - Hercwest Visit 1 -- F606W (07) - The Origin of Ultra-Faint Galaxies

Tue Apr 16 20:01:59 GMT 2019

Visit	Proposal 15182, Hercwest Visit 1 -- F606W (07), completed Diagnostic Status: Warning Scientific Instruments: WFC3/UVIS, ACS/WFC Special Requirements: ORIENT 80D TO 110 D <i>Comments: We are splitting our 10 orbits of Hercwest into 4 visits. The initial visit should have an ORIENT between 80 and 110 degrees. Coordinated parallels with WFC3 will be taken. The 2nd through 4th visits will have the same orientation as the initial visit.</i> <i>Visit 1 and Visit 3 for Hercwest are 2-orbit visits, with a standard ACS-WFC-DITHER-BOX. Visit 2 and Visit 4 are 3-orbits, with a standard ACS-WFC-DITHER-BOX, and then a small-scale ACS-WFC-DITHER-LINE in the third orbit. This will ultimately give 5 orbits per filter, ten orbits total.</i>									
	(Hercwest Visit 1 -- F606W (07)) Warning (Orbit Planner): ORBITAL VISIBILITY OVERRUN (Hercwest Visit 1 -- F606W (07)) Warning (Orbit Planner): ORBITAL VISIBILITY OVERRUN									
Diagnosics										
Patterns	#	Primary Pattern	Secondary Pattern	Exposures						
	(1)	Pattern Type=ACS-WFC-DITHER-BOX Purpose=DITHER Number Of Points=4 Point Spacing=0.262 Line Spacing=0.192	Coordinate Frame=POS-TARG Pattern Orientation=18.39 Angle Between Sides=68.14 Center Pattern=false		(1-2)					
Fixed Targets	#	Name	Target Coordinates	Targ. Coord. Corrections	Fluxes	Miscellaneous				
	(2)	HERCWEST	RA: 16 30 21.0071 (247.5875296d) Dec: +12 51 43.77 (12.86216d) Equinox: J2000		V=14.6+/-0.2	Reference Frame: ICRS				
<i>Comments: Category=GALAXY Description=[DWARF SPHEROIDAL]</i>										
Exposures	#	Label	Target	Config,Mode,Aperture	Spectral Els.	Opt. Params.	Special Reqs.	Groups	Exp. Time (Total)/[Actual Dur.]	Orbit
	1	(2) HERCWEST	HERCWEST	ACS/WFC, ACCUM, WFC	F606W			Pattern 1, Exps 1-2 in Hercwest Visit 1 -- F606W (07) (1)	1200.0 Secs (5188 Secs)	
								Prime + Parallel Group 1-2 in Pattern 1, Exps 1-2 in Hercwest Visit 1 -- F606W (07)	[==>1249.0 Secs (Pattern 1)] [==>1249.0 Secs (Pattern 2)]	[1]
									[==>1345.0 Secs (Pattern 3)] [==>1345.0 Secs (Pattern 4)]	[2]
2	(2) HERCWEST	HERCWEST	WFC3/UVIS, ACCUM, UVIS	F606W				Pattern 1, Exps 1-2 in Hercwest Visit 1 -- F606W (07) (1)	1200. Secs (5278 Secs)	
								Prime + Parallel Group 1-2 in Pattern 1, Exps 1-2 in Hercwest Visit 1 -- F606W (07)	[==>1309.0 Secs (Pattern 1)] [==>1259.0 Secs (Pattern 2)]	[1]
									[==>1355.0 Secs (Pattern 3)] [==>1355.0 Secs (Pattern 4)]	[2]

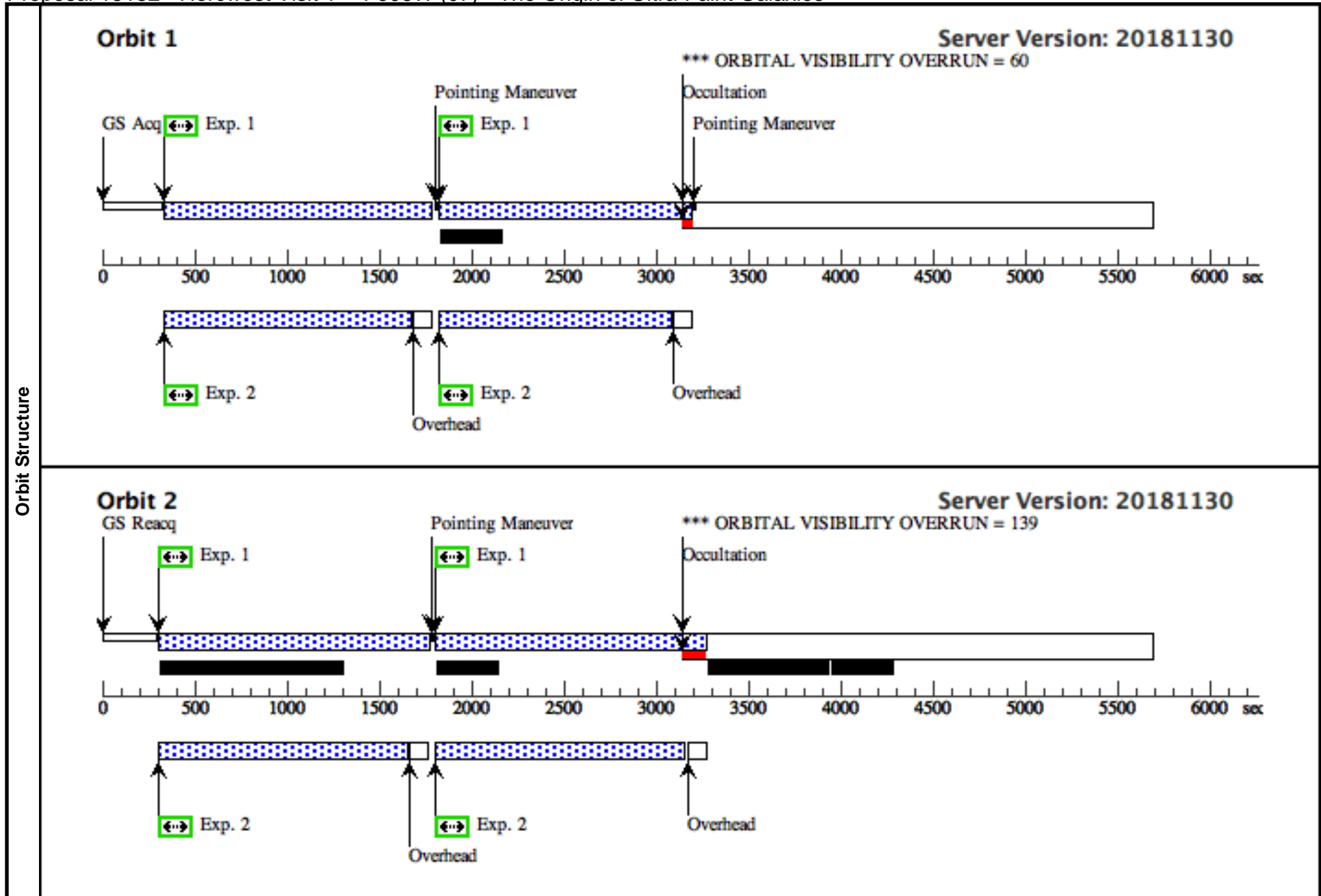

Proposal 15182 - Hercwest Visit 2 -- F606W (08) - The Origin of Ultra-Faint Galaxies

Tue Apr 16 20:01:59 GMT 2019

Visit	<p>Proposal 15182, Hercwest Visit 2 -- F606W (08), failed</p> <p>Diagnostic Status: Warning</p> <p>Scientific Instruments: WFC3/UVIS, ACS/WFC</p> <p>Special Requirements: SAME ORIENT AS 07</p> <p><i>Comments: We are splitting our 10 orbits of Hercwest into 4 visits. The initial visit should have an ORIENT between 80 and 110 degrees. Coordinated parallels with WFC3 will be taken. The 2nd through 4th visits will have the same orientation as the initial visit.</i></p> <p><i>Visit 1 and Visit 3 for Hercwest are 2-orbit visits, with a standard ACS-WFC-DITHER-BOX. Visit 2 and Visit 4 are 3-orbits, with a standard ACS-WFC-DITHER-BOX, and then a small-scale ACS-WFC-DITHER-LINE in the third orbit. This will ultimately give 5 orbits per filter, ten orbits total.</i></p>					
	<p>(Hercwest Visit 2 -- F606W (08)) Warning (Orbit Planner): ORBITAL VISIBILITY OVERRUN</p> <p>(Hercwest Visit 2 -- F606W (08)) Warning (Orbit Planner): ORBITAL VISIBILITY OVERRUN</p> <p>(Hercwest Visit 2 -- F606W (08)) Warning (Orbit Planner): ORBITAL VISIBILITY OVERRUN</p>					
Diagnosics						
Patterns	#	Primary Pattern	Secondary Pattern	Exposures		
	(1)	Pattern Type=ACS-WFC-DITHER-BOX Purpose=DITHER Number Of Points=4 Point Spacing=0.262 Line Spacing=0.192	Coordinate Frame=POS-TARG Pattern Orientation=18.39 Angle Between Sides=68.14 Center Pattern=false		(1-2)	
	(2)	Pattern Type=ACS-WFC-DITHER-LINE Purpose=DITHER Number Of Points=2 Point Spacing=0.149 Line Spacing=	Coordinate Frame=POS-TARG Pattern Orientation=34.29 Angle Between Sides= Center Pattern=false		(3-4)	
Fixed Targets	#	Name	Target Coordinates	Targ. Coord. Corrections	Fluxes	Miscellaneous
	(2)	HERCWEST	RA: 16 30 21.0071 (247.5875296d) Dec: +12 51 43.77 (12.86216d) Equinox: J2000		V=14.6+/-0.2	Reference Frame: ICRS
<p><i>Comments:</i> <i>Category=GALAXY</i> <i>Description=[DWARF SPHEROIDAL]</i></p>						

Proposal 15182 - Hercwest Visit 2 -- F606W (08) - The Origin of Ultra-Faint Galaxies

Exposures	#	Label	Target	Config,Mode,Aperture	Spectral Els.	Opt. Params.	Special Reqs.	Groups	Exp. Time (Total)/[Actual Dur.]	Orbit
	1		(2) HERCWEST	ACS/WFC, ACCUM, WFC	F606W			Pattern 1, Exps 1-2 in Hercwest Visit 2 -- F606W (08) (1)	1200.0 Secs (5188 Secs)	
								Prime + Parallel Group 1-2 in Pattern 1, Exps 1-2 in Hercwest Visit 2 -- F606W (08)	[==>1249.0 Secs (Pattern 1)]	[1]
									[==>1249.0 Secs (Pattern 2)]	
									[==>1345.0 Secs (Pattern 3)]	[2]
								[==>1345.0 Secs (Pattern 4)]		
2		(2) HERCWEST	WFC3/UVIS, ACCUM, UVIS	F606W			Pattern 1, Exps 1-2 in Hercwest Visit 2 -- F606W (08) (1)	1200. Secs (5278 Secs)		
							Prime + Parallel Group 1-2 in Pattern 1, Exps 1-2 in Hercwest Visit 2 -- F606W (08)	[==>1309.0 Secs (Pattern 1)]	[1]	
								[==>1259.0 Secs (Pattern 2)]		
								[==>1355.0 Secs (Pattern 3)]	[2]	
								[==>1355.0 Secs (Pattern 4)]		
3		(2) HERCWEST	ACS/WFC, ACCUM, WFC	F606W			Pattern 2, Exps 3-4 in Hercwest Visit 2 -- F606W (08) (2)	1150.0 Secs (2686 Secs)		
							Prime + Parallel Group 3-4 in Pattern 2, Exps 3-4 in Hercwest Visit 2 -- F606W (08)	[==>1343.0 Secs (Pattern 1)]	[3]	
								[==>1343.0 Secs (Pattern 2)]		
4		(2) HERCWEST	WFC3/UVIS, ACCUM, UVIS	F606W			Pattern 2, Exps 3-4 in Hercwest Visit 2 -- F606W (08) (2)	1150. Secs (2706 Secs)		
							Prime + Parallel Group 3-4 in Pattern 2, Exps 3-4 in Hercwest Visit 2 -- F606W (08)	[==>1353.0 Secs (Pattern 1)]	[3]	
								[==>1353.0 Secs (Pattern 2)]		

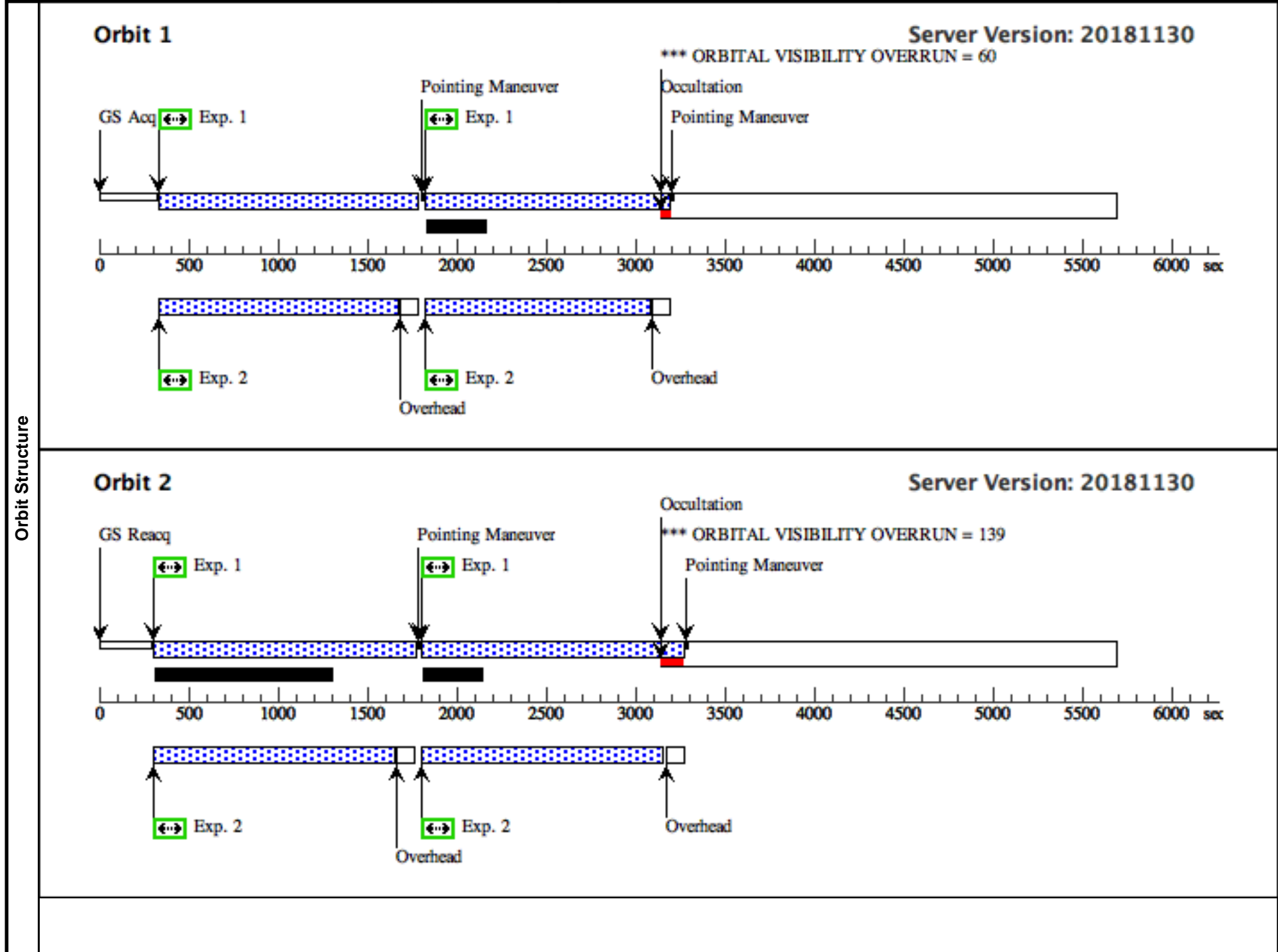

Orbit Structure

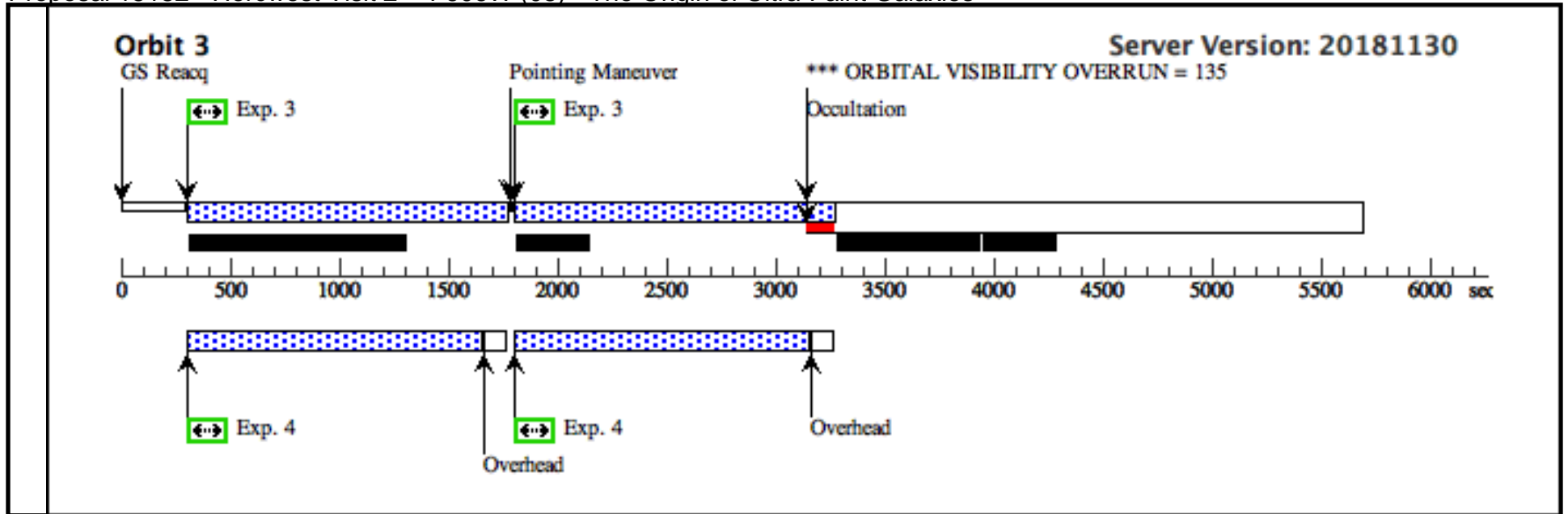

Proposal 15182 - Hercwest Visit 3 -- F814W (09) - The Origin of Ultra-Faint Galaxies

Tue Apr 16 20:01:59 GMT 2019

Visit	Proposal 15182, Hercwest Visit 3 -- F814W (09), completed Diagnostic Status: Warning Scientific Instruments: WFC3/UVIS, ACS/WFC Special Requirements: SAME ORIENT AS 07 <i>Comments: We are splitting our 10 orbits of Hercwest into 4 visits. The initial visit should have an ORIENT between 80 and 110 degrees. Coordinated parallels with WFC3 will be taken. The 2nd through 4th visits will have the same orientation as the initial visit.</i> <i>Visit 1 and Visit 3 for Hercwest are 2-orbit visits, with a standard ACS-WFC-DITHER-BOX. Visit 2 and Visit 4 are 3-orbits, with a standard ACS-WFC-DITHER-BOX, and then a small-scale ACS-WFC-DITHER-LINE in the third orbit. This will ultimately give 5 orbits per filter, ten orbits total.</i>									
	(Hercwest Visit 3 -- F814W (09)) Warning (Orbit Planner): ORBITAL VISIBILITY OVERRUN (Hercwest Visit 3 -- F814W (09)) Warning (Orbit Planner): ORBITAL VISIBILITY OVERRUN									
Diagnosics										
Patterns	#	Primary Pattern	Secondary Pattern	Exposures						
	(1)	Pattern Type=ACS-WFC-DITHER-BOX Purpose=DITHER Number Of Points=4 Point Spacing=0.262 Line Spacing=0.192	Coordinate Frame=POS-TARG Pattern Orientation=18.39 Angle Between Sides=68.14 Center Pattern=false		(1-2)					
Fixed Targets	#	Name	Target Coordinates	Targ. Coord. Corrections	Fluxes	Miscellaneous				
	(2)	HERCWEST	RA: 16 30 21.0071 (247.5875296d) Dec: +12 51 43.77 (12.86216d) Equinox: J2000		V=14.6+/-0.2	Reference Frame: ICRS				
<i>Comments: Category=GALAXY Description=[DWARF SPHEROIDAL]</i>										
Exposures	#	Label	Target	Config,Mode,Aperture	Spectral Els.	Opt. Params.	Special Reqs.	Groups	Exp. Time (Total)/[Actual Dur.]	Orbit
	1	(2) HERCWEST		ACS/WFC, ACCUM, WFC	F814W			Pattern 1, Exps 1-2 in Hercwest Visit 3 -- F814W (09) (1)	1200.0 Secs (5188 Secs)	
								Prime + Parallel Group 1-2 in Pattern 1, Exps 1-2 in Hercwest Visit 3 -- F814W (09)	[==>1249.0 Secs (Pattern 1)] [==>1249.0 Secs (Pattern 2)]	[1]
									[==>1345.0 Secs (Pattern 3)] [==>1345.0 Secs (Pattern 4)]	[2]
2	(2) HERCWEST		WFC3/UVIS, ACCUM, UVIS	F814W				Pattern 1, Exps 1-2 in Hercwest Visit 3 -- F814W (09) (1)	1200. Secs (5278 Secs)	
								Prime + Parallel Group 1-2 in Pattern 1, Exps 1-2 in Hercwest Visit 3 -- F814W (09)	[==>1309.0 Secs (Pattern 1)] [==>1259.0 Secs (Pattern 2)]	[1]
									[==>1355.0 Secs (Pattern 3)] [==>1355.0 Secs (Pattern 4)]	[2]

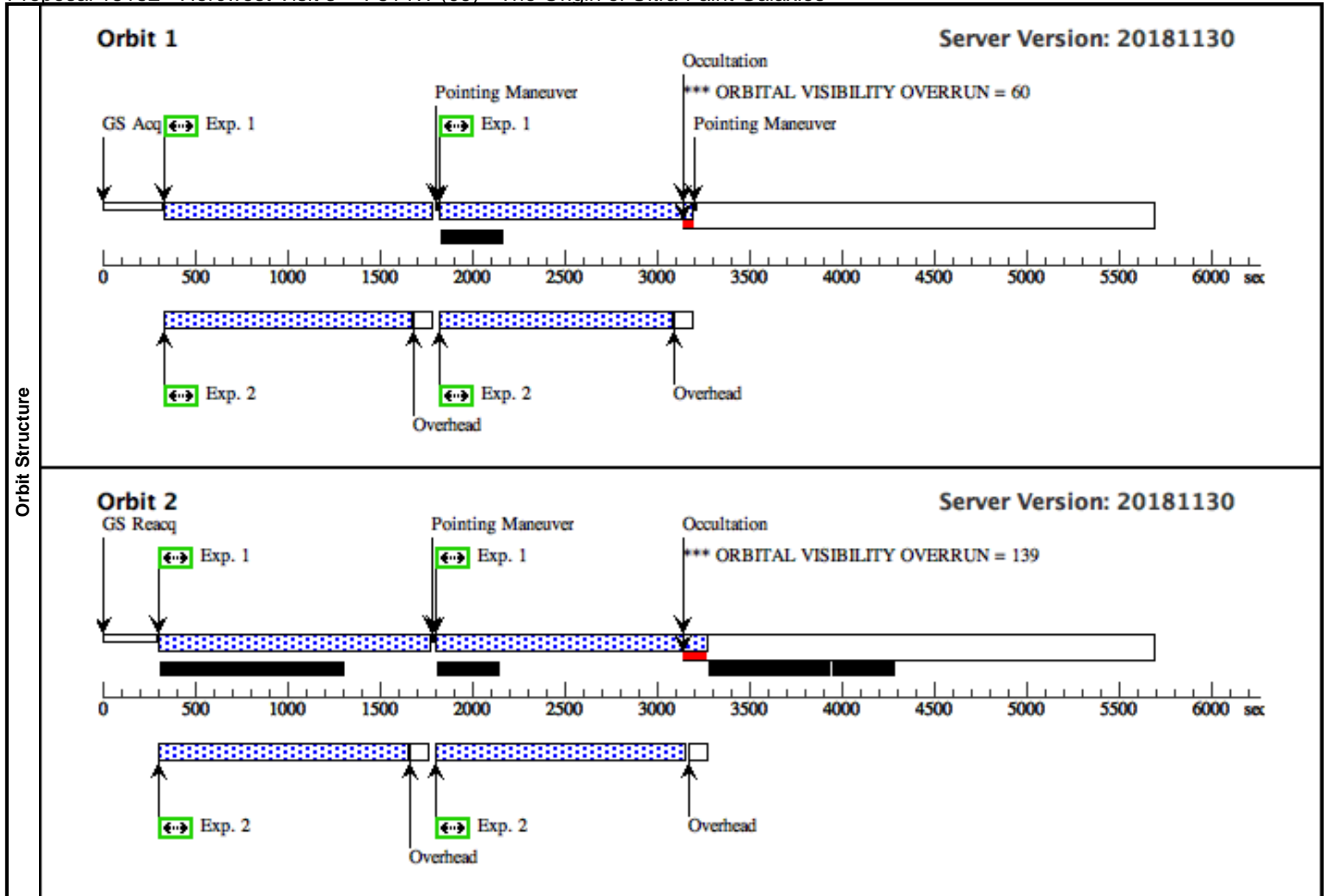

Proposal 15182 - Hercwest Visit 4 -- F814W (10) - The Origin of Ultra-Faint Galaxies

Tue Apr 16 20:01:59 GMT 2019

Visit	<p>Proposal 15182, Hercwest Visit 4 -- F814W (10), failed</p> <p>Diagnostic Status: Warning</p> <p>Scientific Instruments: WFC3/UVIS, ACS/WFC</p> <p>Special Requirements: SAME ORIENT AS 07</p> <p><i>Comments: We are splitting our 10 orbits of Hercwest into 4 visits. The initial visit should have an ORIENT between 80 and 110 degrees. Coordinated parallels with WFC3 will be taken. The 2nd through 4th visits will have the same orientation as the initial visit.</i></p> <p><i>Visit 1 and Visit 3 for Hercwest are 2-orbit visits, with a standard ACS-WFC-DITHER-BOX. Visit 2 and Visit 4 are 3-orbits, with a standard ACS-WFC-DITHER-BOX, and then a small-scale ACS-WFC-DITHER-LINE in the third orbit. This will ultimately give 5 orbits per filter, ten orbits total.</i></p>					
	<p>(Hercwest Visit 4 -- F814W (10)) Warning (Orbit Planner): ORBITAL VISIBILITY OVERRUN</p> <p>(Hercwest Visit 4 -- F814W (10)) Warning (Orbit Planner): ORBITAL VISIBILITY OVERRUN</p> <p>(Hercwest Visit 4 -- F814W (10)) Warning (Orbit Planner): ORBITAL VISIBILITY OVERRUN</p>					
Diagnosics						
Patterns	#	Primary Pattern	Secondary Pattern	Exposures		
	(1)	Pattern Type=ACS-WFC-DITHER-BOX Purpose=DITHER Number Of Points=4 Point Spacing=0.262 Line Spacing=0.192	Coordinate Frame=POS-TARG Pattern Orientation=18.39 Angle Between Sides=68.14 Center Pattern=false		(1-2)	
	(2)	Pattern Type=ACS-WFC-DITHER-LINE Purpose=DITHER Number Of Points=2 Point Spacing=0.149 Line Spacing=	Coordinate Frame=POS-TARG Pattern Orientation=34.29 Angle Between Sides= Center Pattern=false		(3-4)	
Fixed Targets	#	Name	Target Coordinates	Targ. Coord. Corrections	Fluxes	Miscellaneous
	(2)	HERCWEST	RA: 16 30 21.0071 (247.5875296d) Dec: +12 51 43.77 (12.86216d) Equinox: J2000		V=14.6+/-0.2	Reference Frame: ICRS
<p><i>Comments:</i> <i>Category=GALAXY</i> <i>Description=[DWARF SPHEROIDAL]</i></p>						

Proposal 15182 - Hercwest Visit 4 -- F814W (10) - The Origin of Ultra-Faint Galaxies

Exposures	#	Label	Target	Config,Mode,Aperture	Spectral Els.	Opt. Params.	Special Reqs.	Groups	Exp. Time (Total)/[Actual Dur.]	Orbit
	1		(2) HERCWEST	ACS/WFC, ACCUM, WFC	F814W			Pattern 1, Exps 1-2 in Hercwest Visit 4 -- F814W (10) (1)	1200.0 Secs (5188 Secs)	
								Prime + Parallel Group 1-2 in Pattern 1, Exps 1-2 in Hercwest Visit 4 -- F814W (10)	[==>1249.0 Secs (Pattern 1)] [==>1249.0 Secs (Pattern 2)]	[1]
									[==>1345.0 Secs (Pattern 3)] [==>1345.0 Secs (Pattern 4)]	[2]
2		(2) HERCWEST	WFC3/UVIS, ACCUM, UVIS	F814W			Pattern 1, Exps 1-2 in Hercwest Visit 4 -- F814W (10) (1)	1200. Secs (5278 Secs)		
							Prime + Parallel Group 1-2 in Pattern 1, Exps 1-2 in Hercwest Visit 4 -- F814W (10)	[==>1309.0 Secs (Pattern 1)] [==>1259.0 Secs (Pattern 2)]	[1]	
								[==>1355.0 Secs (Pattern 3)] [==>1355.0 Secs (Pattern 4)]	[2]	
3		(2) HERCWEST	ACS/WFC, ACCUM, WFC	F814W			Pattern 2, Exps 3-4 in Hercwest Visit 4 -- F814W (10) (2)	1150.0 Secs (2686 Secs)		
							Prime + Parallel Group 3-4 in Pattern 2, Exps 3-4 in Hercwest Visit 4 -- F814W (10)	[==>1343.0 Secs (Pattern 1)] [==>1343.0 Secs (Pattern 2)]	[3]	
4		(2) HERCWEST	WFC3/UVIS, ACCUM, UVIS	F814W			Pattern 2, Exps 3-4 in Hercwest Visit 4 -- F814W (10) (2)	1150. Secs (2706 Secs)		
							Prime + Parallel Group 3-4 in Pattern 2, Exps 3-4 in Hercwest Visit 4 -- F814W (10)	[==>1353.0 Secs (Pattern 1)] [==>1353.0 Secs (Pattern 2)]	[3]	

Orbit 1

Server Version: 20181130

*** ORBITAL VISIBILITY OVERRUN = 60

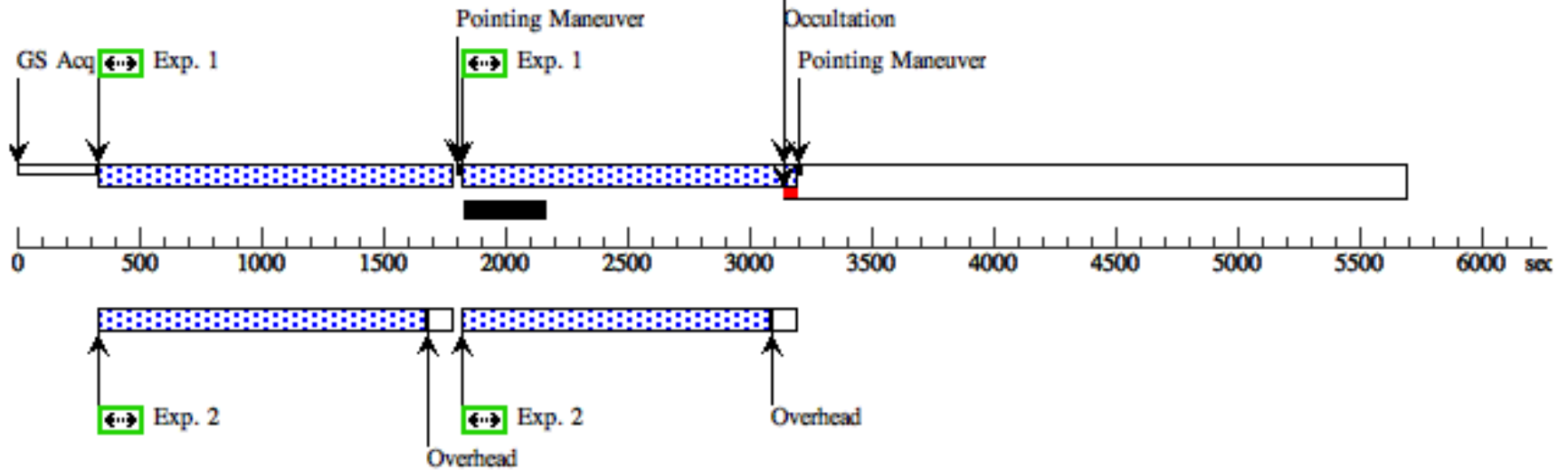

Orbit 2

Server Version: 20181130

*** ORBITAL VISIBILITY OVERRUN = 139

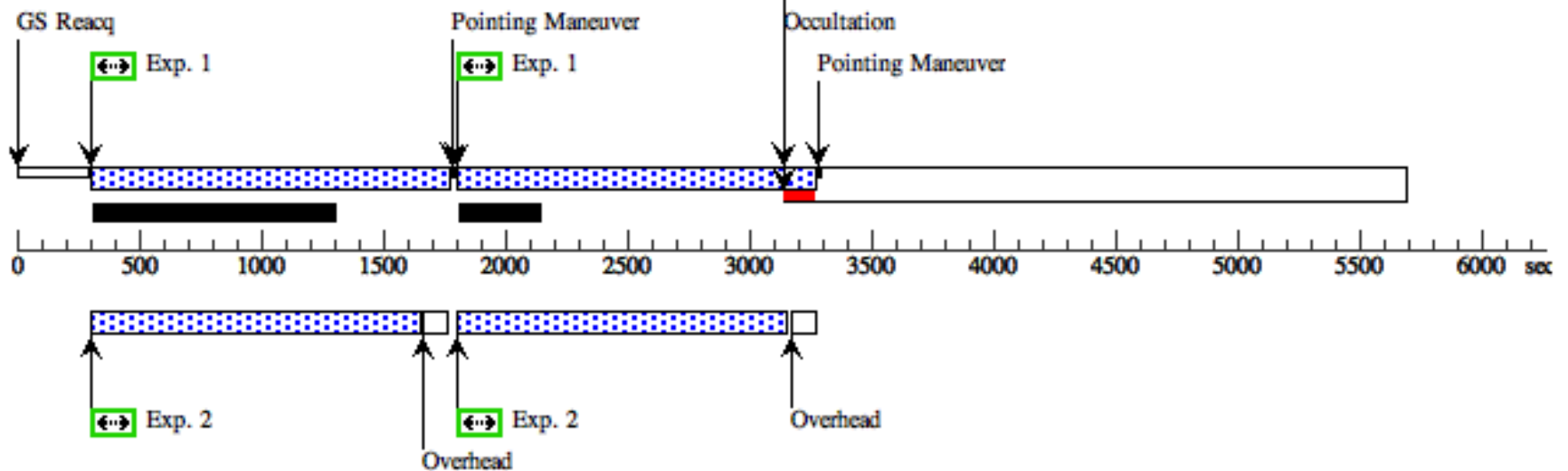

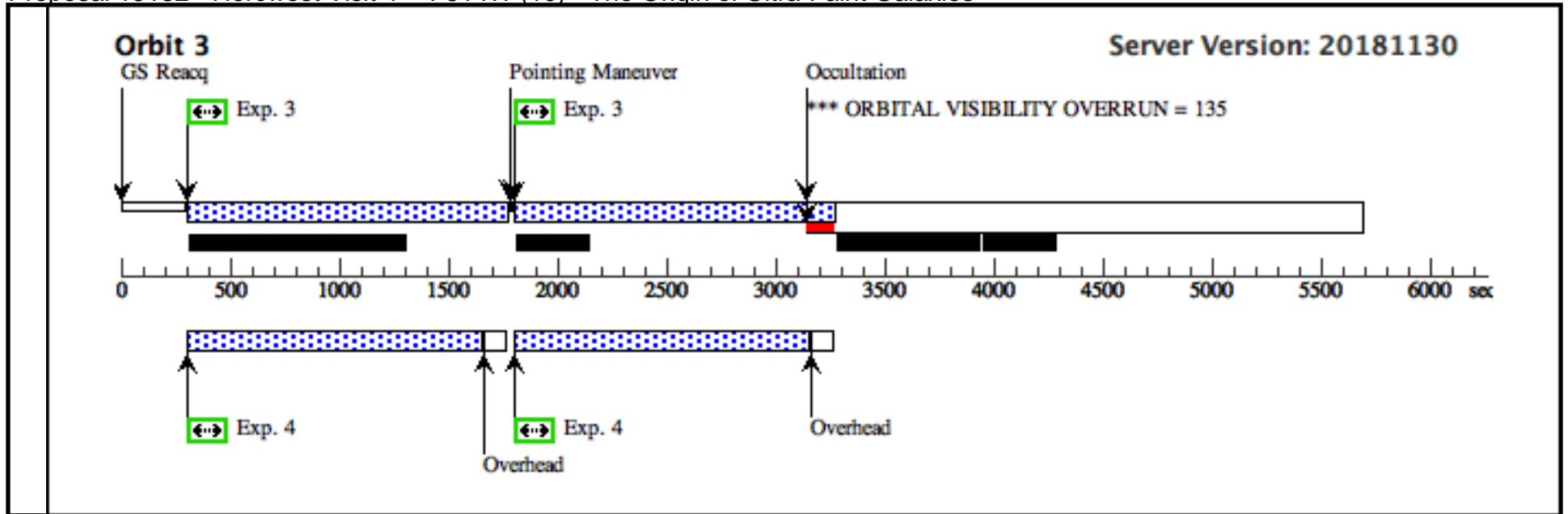

Proposal 15182 - Hercwest Visit 2 -- F606W (58) - The Origin of Ultra-Faint Galaxies

Tue Apr 16 20:01:59 GMT 2019

Visit	<p>Proposal 15182, Hercwest Visit 2 -- F606W (58), scheduling</p> <p>Diagnostic Status: No Diagnostics</p> <p>Scientific Instruments: WFC3/UVIS, ACS/WFC</p> <p>Special Requirements: SAME ORIENT AS 07</p> <p><i>Comments: We are splitting our 10 orbits of Hercwest into 4 visits. The initial visit should have an ORIENT between 80 and 110 degrees. Coordinated parallels with WFC3 will be taken. The 2nd through 4th visits will have the same orientation as the initial visit.</i></p> <p><i>Visit 1 and Visit 3 for Hercwest are 2-orbit visits, with a standard ACS-WFC-DITHER-BOX. Visit 2 and Visit 4 are 3-orbits, with a standard ACS-WFC-DITHER-BOX, and then a small-scale ACS-WFC-DITHER-LINE in the third orbit. This will ultimately give 5 orbits per filter, ten orbits total.</i></p> <p><i>Repeat of Visit 08</i></p>					
Patterns	#	Primary Pattern	Secondary Pattern	Exposures		
	(1)	Pattern Type=ACS-WFC-DITHER-BOX Purpose=DITHER Number Of Points=4 Point Spacing=0.262 Line Spacing=0.192	Coordinate Frame=POS-TARG Pattern Orientation=18.39 Angle Between Sides=68.14 Center Pattern=false		(1-2)	
	(2)	Pattern Type=ACS-WFC-DITHER-LINE Purpose=DITHER Number Of Points=2 Point Spacing=0.149 Line Spacing=	Coordinate Frame=POS-TARG Pattern Orientation=34.29 Angle Between Sides= Center Pattern=false		(3-4)	
Fixed Targets	#	Name	Target Coordinates	Targ. Coord. Corrections	Fluxes	Miscellaneous
	(2)	HERCWEST	RA: 16 30 21.0071 (247.5875296d) Dec: +12 51 43.77 (12.86216d) Equinox: J2000		V=14.6+/-0.2	Reference Frame: ICRS
	<p><i>Comments:</i></p> <p><i>Category=GALAXY</i></p> <p><i>Description=[DWARF SPHEROIDAL]</i></p>					

Proposal 15182 - Herctest Visit 2 -- F606W (58) - The Origin of Ultra-Faint Galaxies

Exposures	#	Label	Target	Config,Mode,Aperture	Spectral Els.	Opt. Params.	Special Reqs.	Groups	Exp. Time (Total)/[Actual Dur.]	Orbit
	1		(2) HERCWEST	ACS/WFC, ACCUM, WFC	F606W			Pattern 1, Exps 1-2 in Herctest Visit 2 -- F606W (58) (1)	1200.0 Secs (4988 Secs)	
								Prime + Parallel Group 1-2 in Pattern 1, Exps 1-2 in Herctest Visit 2 -- F606W (58)	[==>1219.0 Secs (Pattern 1)] [==>1219.0 Secs (Pattern 2)]	[1]
									[==>1275.0 Secs (Pattern 3)] [==>1275.0 Secs (Pattern 4)]	[2]
2		(2) HERCWEST	WFC3/UVIS, ACCUM, UVIS	F606W			Pattern 1, Exps 1-2 in Herctest Visit 2 -- F606W (58) (1)	1200. Secs (5078 Secs)		
							Prime + Parallel Group 1-2 in Pattern 1, Exps 1-2 in Herctest Visit 2 -- F606W (58)	[==>1279.0 Secs (Pattern 1)] [==>1229.0 Secs (Pattern 2)]	[1]	
								[==>1285.0 Secs (Pattern 3)] [==>1285.0 Secs (Pattern 4)]	[2]	
3		(2) HERCWEST	ACS/WFC, ACCUM, WFC	F606W			Pattern 2, Exps 3-4 in Herctest Visit 2 -- F606W (58) (2)	1150.0 Secs (2550 Secs)		
							Prime + Parallel Group 3-4 in Pattern 2, Exps 3-4 in Herctest Visit 2 -- F606W (58)	[==>1275.0 Secs (Pattern 1)] [==>1275.0 Secs (Pattern 2)]	[3]	
4		(2) HERCWEST	WFC3/UVIS, ACCUM, UVIS	F606W			Pattern 2, Exps 3-4 in Herctest Visit 2 -- F606W (58) (2)	1150. Secs (2570 Secs)		
							Prime + Parallel Group 3-4 in Pattern 2, Exps 3-4 in Herctest Visit 2 -- F606W (58)	[==>1285.0 Secs (Pattern 1)] [==>1285.0 Secs (Pattern 2)]	[3]	

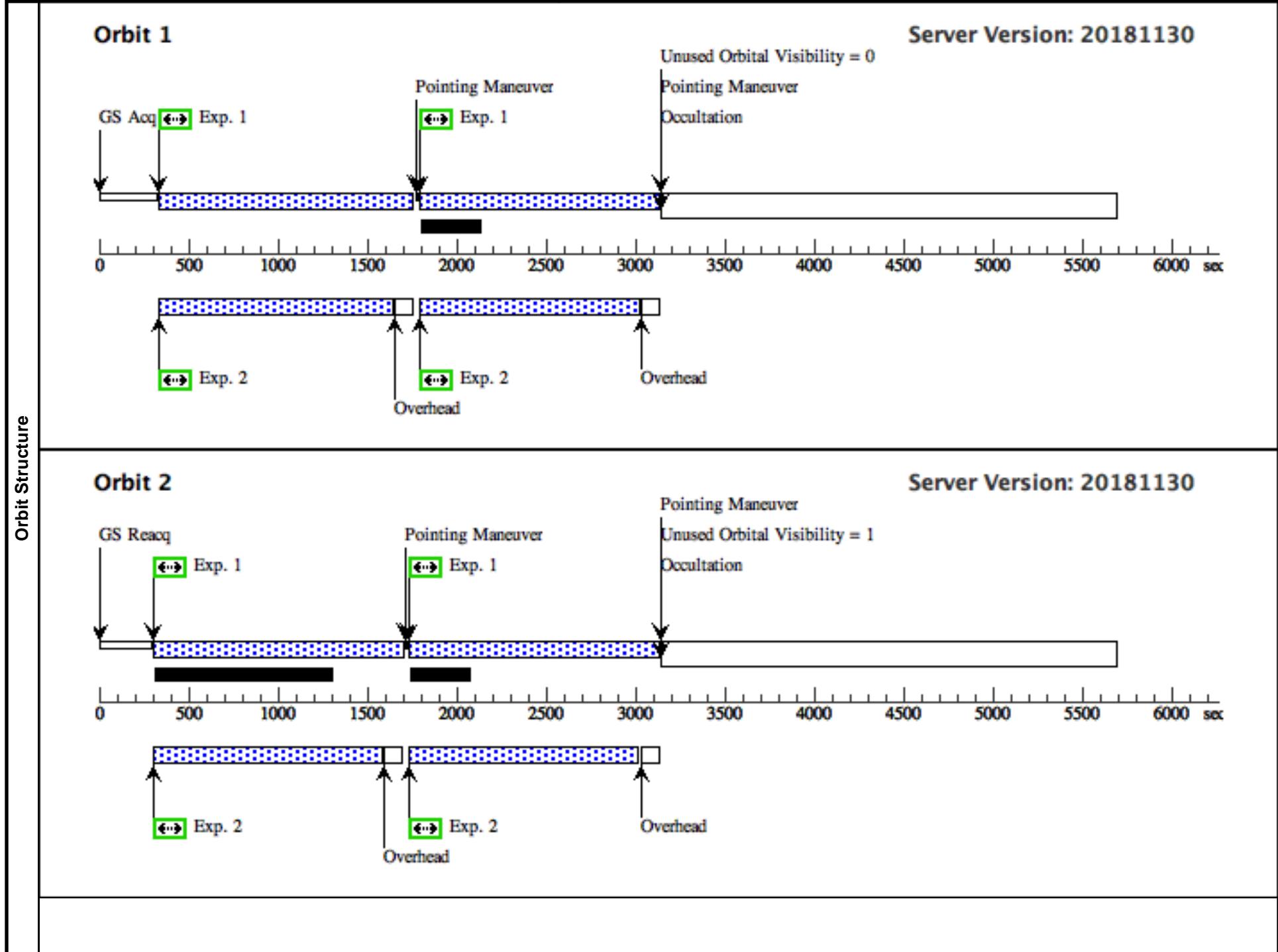

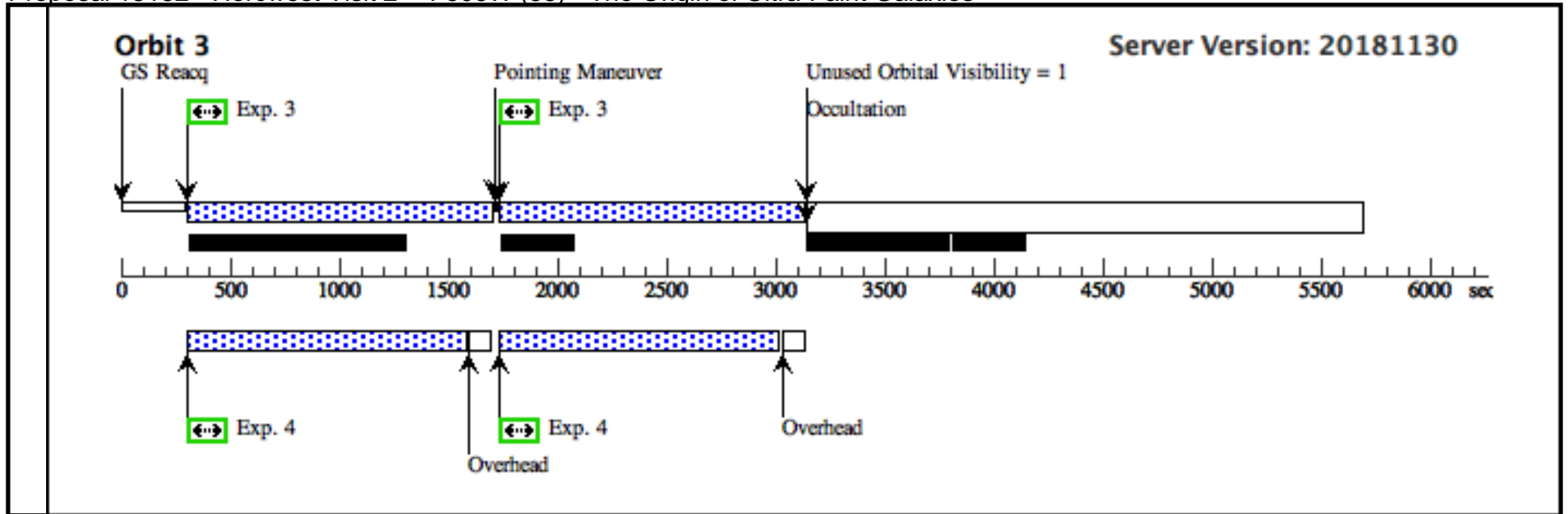

Proposal 15182 - Hercwest Visit 4 -- F814W (60) - The Origin of Ultra-Faint Galaxies

Tue Apr 16 20:01:59 GMT 2019

Visit	<p>Proposal 15182, Hercwest Visit 4 -- F814W (60), scheduling</p> <p>Diagnostic Status: No Diagnostics</p> <p>Scientific Instruments: WFC3/UVIS, ACS/WFC</p> <p>Special Requirements: SAME ORIENT AS 07</p> <p><i>Comments: We are splitting our 10 orbits of Hercwest into 4 visits. The initial visit should have an ORIENT between 80 and 110 degrees. Coordinated parallels with WFC3 will be taken. The 2nd through 4th visits will have the same orientation as the initial visit.</i></p> <p><i>Visit 1 and Visit 3 for Hercwest are 2-orbit visits, with a standard ACS-WFC-DITHER-BOX. Visit 2 and Visit 4 are 3-orbits, with a standard ACS-WFC-DITHER-BOX, and then a small-scale ACS-WFC-DITHER-LINE in the third orbit. This will ultimately give 5 orbits per filter, ten orbits total.</i></p> <p><i>Repeat of Visit 10</i></p>					
Patterns	#	Primary Pattern	Secondary Pattern	Exposures		
	(1)	Pattern Type=ACS-WFC-DITHER-BOX Purpose=DITHER Number Of Points=4 Point Spacing=0.262 Line Spacing=0.192	Coordinate Frame=POS-TARG Pattern Orientation=18.39 Angle Between Sides=68.14 Center Pattern=false		(1-2)	
(2)	Pattern Type=ACS-WFC-DITHER-LINE Purpose=DITHER Number Of Points=2 Point Spacing=0.149 Line Spacing=	Coordinate Frame=POS-TARG Pattern Orientation=34.29 Angle Between Sides= Center Pattern=false		(3-4)		
Fixed Targets	#	Name	Target Coordinates	Targ. Coord. Corrections	Fluxes	Miscellaneous
	(2)	HERCWEST	RA: 16 30 21.0071 (247.5875296d) Dec: +12 51 43.77 (12.86216d) Equinox: J2000		V=14.6+/-0.2	Reference Frame: ICRS
<p><i>Comments:</i> <i>Category=GALAXY</i> <i>Description=[DWARF SPHEROIDAL]</i></p>						

Proposal 15182 - Herctest Visit 4 -- F814W (60) - The Origin of Ultra-Faint Galaxies

Exposures	#	Label	Target	Config,Mode,Aperture	Spectral Els.	Opt. Params.	Special Reqs.	Groups	Exp. Time (Total)/[Actual Dur.]	Orbit
	1		(2) HERCWEST	ACS/WFC, ACCUM, WFC	F814W			Pattern 1, Exps 1-2 in Herctest Visit 4 -- F814W (60) (1)	1200.0 Secs (4988 Secs)	
								Prime + Parallel Group 1-2 in Pattern 1, Exps 1-2 in Herctest Visit 4 -- F814W (60)	[==>1219.0 Secs (Pattern 1)] [==>1219.0 Secs (Pattern 2)]	[1]
									[==>1275.0 Secs (Pattern 3)] [==>1275.0 Secs (Pattern 4)]	[2]
2		(2) HERCWEST	WFC3/UVIS, ACCUM, UVIS	F814W			Pattern 1, Exps 1-2 in Herctest Visit 4 -- F814W (60) (1)	1200. Secs (5078 Secs)		
							Prime + Parallel Group 1-2 in Pattern 1, Exps 1-2 in Herctest Visit 4 -- F814W (60)	[==>1279.0 Secs (Pattern 1)] [==>1229.0 Secs (Pattern 2)]	[1]	
								[==>1285.0 Secs (Pattern 3)] [==>1285.0 Secs (Pattern 4)]	[2]	
3		(2) HERCWEST	ACS/WFC, ACCUM, WFC	F814W			Pattern 2, Exps 3-4 in Herctest Visit 4 -- F814W (60) (2)	1150.0 Secs (2550 Secs)		
							Prime + Parallel Group 3-4 in Pattern 2, Exps 3-4 in Herctest Visit 4 -- F814W (60)	[==>1275.0 Secs (Pattern 1)] [==>1275.0 Secs (Pattern 2)]	[3]	
4		(2) HERCWEST	WFC3/UVIS, ACCUM, UVIS	F814W			Pattern 2, Exps 3-4 in Herctest Visit 4 -- F814W (60) (2)	1150. Secs (2570 Secs)		
							Prime + Parallel Group 3-4 in Pattern 2, Exps 3-4 in Herctest Visit 4 -- F814W (60)	[==>1285.0 Secs (Pattern 1)] [==>1285.0 Secs (Pattern 2)]	[3]	

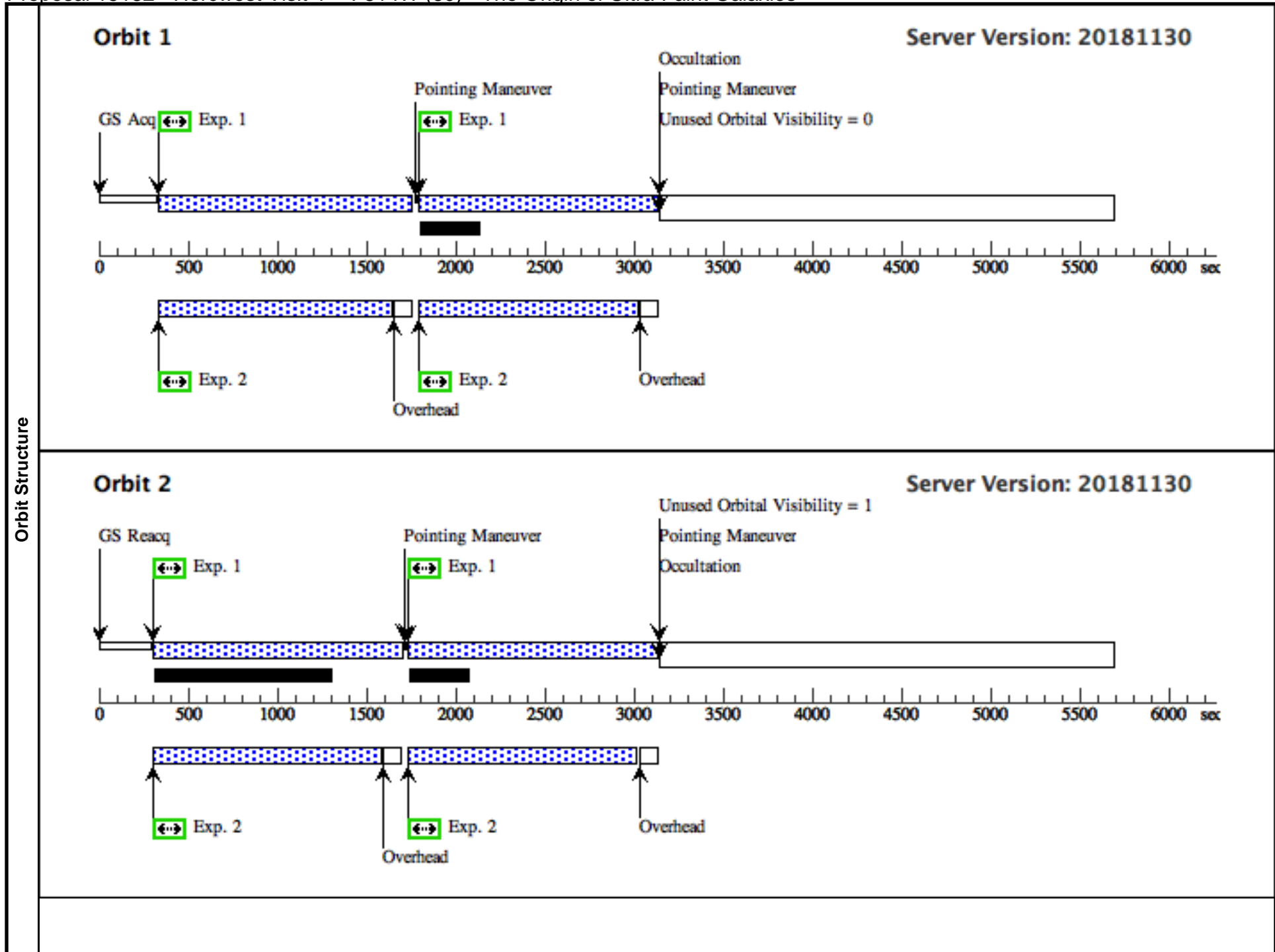

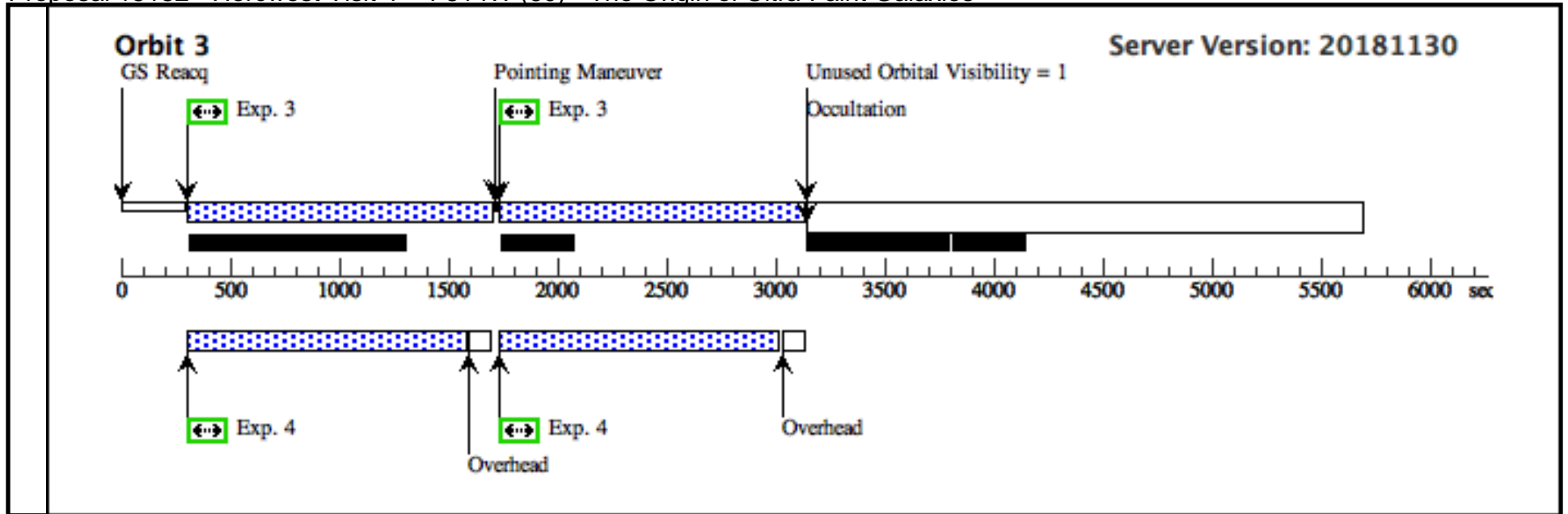

Proposal 15182 - Herceast Visit 4, 1 orbit -- F814W (61) - The Origin of Ultra-Faint Galaxies

Tue Apr 16 20:01:59 GMT 2019

Visit	Proposal 15182, Herceast Visit 4, 1 orbit -- F814W (61) Diagnostic Status: No Diagnostics Scientific Instruments: WFC3/UVIS, ACS/WFC Special Requirements: SAME ORIENT AS 53 <i>Comments: We are splitting our 10 orbits of Herceast into 4 visits. The initial visit should have an ORIENT between 260 and 290 degrees. Coordinated parallels with WFC3 will be taken. The 2nd through 4th visits will have the same orientation as the initial visit.</i> <i>Visit 1 and Visit 3 for Herceast are 2-orbit visits, with a standard ACS-WFC-DITHER-BOX. Visit 2 and Visit 4 are 3-orbits, with a standard ACS-WFC-DITHER-BOX, and then a small-scale ACS-WFC-DITHER-LINE in the third orbit. This will ultimately give 5 orbits per filter, ten orbits total.</i> <i>This is a partial repeat of Visit 56. Only 1 orbit is needed.</i>									
Patterns	#	Primary Pattern	Secondary Pattern	Exposures						
	(2)	Pattern Type=ACS-WFC-DITHER-LINE Purpose=DITHER Number Of Points=2 Point Spacing=0.149 Line Spacing= Coordinate Frame=POS-TARG Pattern Orientation=34.29 Angle Between Sides= Center Pattern=false		(1-2)						
Fixed Targets	#	Name	Target Coordinates	Targ. Coord. Corrections	Fluxes	Miscellaneous				
	(1)	HERCEAST	RA: 16 31 43.0056 (247.9291900d) Dec: +12 43 43.82 (12.72884d) Equinox: J2000		V=14.6+/-0.2	Reference Frame: ICRS				
<i>Comments: Category=GALAXY Description=[DWARF SPHEROIDAL]</i>										
Exposures	#	Label	Target	Config,Mode,Aperture	Spectral Els.	Opt. Params.	Special Reqs.	Groups	Exp. Time (Total)/[Actual Dur.]	Orbit
	1	(1) HERCEAST		ACS/WFC, ACCUM, WFC	F814W			Pattern 2, Exps 1-2 in Herceast Visit 4, 1 orbit -- F814W (61) (2) Prime + Parallel Group 1-2 in Pattern 2, Exps 1-2 in Herceast Visit 4, 1 orbit -- F814W (61)	1150.0 Secs (2438 Secs) [==>1219.0 Secs (Pattern 1)] [==>1219.0 Secs (Pattern 2)]	[1]
	2	(1) HERCEAST		WFC3/UVIS, ACCUM, UVIS	F814W			Pattern 2, Exps 1-2 in Herceast Visit 4, 1 orbit -- F814W (61) (2) Prime + Parallel Group 1-2 in Pattern 2, Exps 1-2 in Herceast Visit 4, 1 orbit -- F814W (61)	1150. Secs (2508 Secs) [==>1279.0 Secs (Pattern 1)] [==>1229.0 Secs (Pattern 2)]	[1]

