



15192 - Whimper of a Bang: Documenting the Final Days of the Nearby Type Ia Supernova 2011fe

Cycle: 25, Proposal Category: GO
(Availability Mode: SUPPORTED)

INVESTIGATORS

<i>Name</i>	<i>Institution</i>	<i>E-Mail</i>
Prof. Benjamin John Shappee (PI) (Contact)	University of Hawaii	shappee@hawaii.edu
Dr. Krzysztof Z. Stanek (CoI)	The Ohio State University	stanek.32@osu.edu
Dr. Chris S. Kochanek (CoI)	The Ohio State University	ckochanek@astronomy.ohio-state.edu
Dr. Peter M. Garnavich (CoI)	University of Notre Dame	pgarnavi@nd.edu

VISITS

<i>Visit</i>	<i>Targets used in Visit</i>	<i>Configurations used in Visit</i>	<i>Orbits Used</i>	<i>Last Orbit Planner Run</i>	<i>OP Current with Visit?</i>
01	(1) SN-2011FE-UVIS ANY	ACS/WFC WFC3/UVIS	6	07-Mar-2018 21:00:20.0	yes
03	(1) SN-2011FE-UVIS ANY	ACS/WFC WFC3/UVIS	3	07-Mar-2018 21:00:24.0	yes
02	(2) SN-2011FE-IR ANY	ACS/WFC WFC3/IR	4	07-Mar-2018 21:00:27.0	yes

13 Total Orbits Used

ABSTRACT

Even though SNe Ia are crucial to cosmological studies as distance indicators, the exact nature of these systems remains theoretically ambiguous and observationally elusive. However, there is a new hope. The very late-time light curves of SNe Ia harbor important clues to the natures of their progenitor systems. First, the ejecta from the SN will shock heat a non-degenerate companion, leaving it luminous and visible at very late times after the SN has faded. Second, due to nucleosynthetic effects during the explosion, single and double degenerate SNe Ia models are predicted to produce vastly differing amounts of ^{57}Co and ^{55}Fe . ^{57}Co and ^{55}Fe dominate the power of the very late time light curves of SNe Ia after >1050 days after the initial explosion. Broadband observations of the bolometric luminosity at these epochs have the ability to measure the ratio of these two isotopes and thus discriminate between progenitor models. As the brightest SN Ia in nearly 40 years, SN 2011fe offers a prime opportunity to follow a SN Ia to such late epochs. Here we propose HST WFC3 optical and IR photometry of SN 2011fe to observe the transition from a ^{57}Co to a ^{55}Fe powered lightcurve and to constrain a possible shock-heated companion. These observations will place unique constraints on progenitor systems of SNe Ia. SN 2011fe, having been already observed for more than 1600 days and a factor of four million in flux. The observations proposed here would follow SN 2011fe to an epoch 2.5 times later than any other SNe Ia. SN 2011fe is likely to remain the best studied normal SN Ia of our generation and if these observations are not made now, they will likely never be done with Hubble.

OBSERVING DESCRIPTION

The observations proposed here continue a project from Cycles 22 and 23 with the goal of constructing a quasi-bolometric light curve to monitor the late-time evolution of SN 2011fe. We have already obtained four epochs and a fifth epoch is scheduled for September 2016. We propose obtaining two additional epochs during Cycles 24 and 25 at ~ 2100 and ~ 2500 days after t_{Bmax} to well-sample the transition to a dominantly ^{55}Fe powered light curve and to constrain the existence of a shock-heated companion.

The very late-time spectra of SNe Ia predominantly consists of line emission over a very broad range of wavelengths longwards of the UV (where there is little emission). We selected the F438W (B), F555W (V) and F600LP (R+I) filters for WFC3/UVIS and F110W (Y J) and F160W (H) for WFC3/IR. There are a number of reasons this filter combination is ideal for this project: 1) These filters cover 4000 to 17000 Å with no gaps and relatively uniform throughput. Our ground-based spectroscopy and photometry show there is little flux blueward of 4000 Å so we forgo the F336W (U) and UV filters. 2) A single long pass filter would not be sufficient because the shape of the SN spectral energy distribution is known to be changing with ionization (McClelland et al. 2013; Graham et al 2015; Taubenberger et al. 2015, Shappee et al. in prep.). Computing the bolometric luminosity with a single F350LP observation would lead to large systematic uncertainties. However, using individual broad band filters retains some spectral information without the impossible expense of taking a spectrum. Without this information, we could mistake a change in ionization state for a change in the bolometric luminosity or interpret a light echo as a flattening of the bolometric light curve. 3) Finally, the optical filter combination

Proposal 15192 (STScI Edit Number: 2, Created: Wednesday, March 7, 2018 9:00:28 PM EST) - Overview

also attempts to evenly partition the optical energy. In the spectrum obtained 850 days after t_{Bmax} , the wavelength ranges covered by B, V, R, and I, contained 48%, 37%, 21%, 19% of the optical energy. Thus we have kept B and V as separate filters but F600LP covers both the R and I wavelength ranges.

We estimated the number of orbits and exposures needed for our program using the estimated magnitudes shown in Figure 1 and the recommendations in the HST Primer. We require a SNR of 7 and 5 for the 3 optical filters during Cycle 24 and 25, respectively. These SNRs will allow us to construct a quasi-bolometric light curve of SN 2011fe and distinguish between the Ropke et al. (2012) models by ~ 3 sigma at each epoch. Conveniently, these SNRs will also allow us to constrain the light from a possible 1Msun shock-heated companion at the 2 and 3-sigma level during each epoch in the F 555W and F 600LP filters, respectively.

The NIR, however, is not as simple because it appears that SN 2011fe is blended in the Cycle 22 and 23 F110W and F160W observations with nearby, faint, very-red stars.

There is also the concern that crowding and confusion may inhibit our measurement in the optical. Luckily, SN 2011fe exploded in a sparse region of the outer disk of M101 where archival pre-explosion HST images existed. Li et al. (2011) use these images and Keck AO observations of SN 2011fe to constrain the progenitor system. They detect no counter part at the location of the SN and place upper limits of $F435W < 27.87$, $F555W < 27.49$, and $F814W < 26.81$ at its position. These limits are fainter than SN 2011fe is expected to be during all of Cycle 24.

We then used the exposure time calculator to estimate the length of our required observations. The exposure time calculations for all of the observations include both their dates and coordinates to ensure that our estimated times are accurate and that the correct contribution of zodiacal light is accounted for. The estimates are also based on the observed optical spectrum of SN 2011fe taken 850 days after t_{Bmax} which is calibrated to the expected broad-band magnitudes for each epoch. Finally, because no SN Ia has ever been observed at these epochs, changes in the ionization state of SN 2011fe are possible and can not be predicted. This could conceivably significantly change which filters receive the largest portion of the SN flux. Thus, we will use the Cycle 23/24 photometry to determine if the exposure time distribution needs to be adjusted for Cycle 24/25, respectively.

It is important to note that both of the proposed observations in Cycle 24 and Cycle 25 are critical to understanding the late-time evolution of SN 2011fe. Cycle 24 could unveil the existence of a shock-heated companion. But decisively determining if a flattening in the F600LP lightcurve is due to a companion (evolves on a time scale of ~ 1000 years), ^{55}Fe becoming the dominate heating source (half-life of ~ 3 years), or a change in ionization state will be difficult without a latter epoch. If a shock-heated companion is not seen, then the observations in Cycle 25 will represent the

Proposal 15192 (STScI Edit Number: 2, Created: Wednesday, March 7, 2018 9:00:28 PM EST) - Overview

first time we observe a SNe Ia light curve powered by ^{55}Fe . Additionally, difference imaging with the later, deeper epoch will allow us to better deal with crowding, especially in the NIR filters. All of these reasons make late-time observations key.

Finally, because there is still a large and ongoing interest in SN 2011fe, we will waive our 1 year proprietary period and make the data immediately public.

Parallel Observations: As the closest face-on Milky Way analogue, M101 is an important nearby galaxy for many reasons. For example, Shara et al. (2013) have compiled a catalog of 10,000 Wolf-Rayet stars using extensive HST WFC3 He II optical narrow-band imaging. There are also F435W/F555W/F814W/F658N(H α) mosaics covering most of the galaxy (GO 9490, 9492, 9720). We have performed a study of Cepheids using archival ACS data that provides the distance which is commonly used for SN 2011fe (Shappee & Stanek 2011). M101 is an important galaxy for the recent 2.4% determination of the Hubble Constant (Riess et al. 2016). We are surveying the entire galaxy for new Cepheids with the LBT. We include ACS in parallel mode to broaden the archival data base. We have used APT and Aladin to confirm it is possible to place the ACS detector (given the roll restrictions created by the timing of the observations) on both of the two Cepheid fields used for published HST Cepheid distance measurements. Our parallel fields could add another, even deeper, epoch for each field and help to better constrain down Cepheid periods, magnitudes, and reddening in those fields. However, because M101 is such an interesting and large galaxy, an ACS parallel observation at any roll angle would be valuable.

Proposal 15192 - Seventh Epoch (1st Visit) (01) - Whimper of a Bang: Documenting the Final Days of the Nearby Type Ia Supernova ...

Thu Mar 08 02:00:29 GMT 2018

Visit	Proposal 15192, Seventh Epoch (1st Visit) (01), implementation Diagnostic Status: Warning Scientific Instruments: WFC3/UVIS, ACS/WFC Special Requirements: ORIENT 205D TO 230 D; BETWEEN 01-MAR-2018:00:00:00 AND 31-MAR-2018:00:00:00; ON HOLD <i>Comments: 13 orbits were not schedulable together, so we had to split the epoch into at least two visits. However, only up to 6 orbits are schedulable together, so we had to schedule three visits.</i> <i>On Hold Comments: Because of earth glow, orbits will need to be adjusted shortly before execution when sky brightness plots can be made.</i>					
	(Seventh Epoch (1st Visit) (01)) Warning (Orbit Planner): PATTERN AND COORDINATED PARALLEL MISMATCH (Seventh Epoch (1st Visit) (01)) Warning (Orbit Planner): PATTERN AND COORDINATED PARALLEL MISMATCH					
Diagnosics						
Patterns	#	Primary Pattern		Secondary Pattern		Exposures
	(5)	Pattern Type=LINE Purpose=DITHER Number Of Points=3 Point Spacing=0.135 Line Spacing=	Coordinate Frame=POS-TARG Pattern Orientation=46.84 Angle Between Sides= Center Pattern=false	Pattern Type=LINE Purpose=DITHER Number Of Points=2 Point Spacing=0.0198 Line Spacing=	Coordinate Frame=POS-TARG Pattern Orientation=0.0 Angle Between Sides= Center Pattern=false	(1-4)
Fixed Targets	#	Name	Target Coordinates	Targ. Coord. Corrections	Fluxes	Miscellaneous
	(1)	SN-2011FE-UVIS	RA: 14 03 14.3269 (210.8096954d) Dec: +54 16 22.93 (54.27304d) Equinox: J2000		V=27.5+/-1.0	Reference Frame: SIMBAD
<i>Comments: This object was generated by the targetselector and retrieved from the SIMBAD database.</i> Category=EXT-STAR Description=[SUPERNOVA TYPE IA]						

Proposal 15192 - Seventh Epoch (1st Visit) (01) - Whimper of a Bang: Documenting the Final Days of the Nearby Type Ia Supernova ...

#	Label	Target	Config,Mode,Aperture	Spectral Els.	Opt. Params.	Special Reqs.	Groups	Exp. Time (Total)/[Actual Dur.]	Orbit
Exposures	1	WFC3_F55 5W	(1) SN-2011FE-UVI S	WFC3/UVIS, ACCUM, UVIS	F555W	GS ACQ SCENARI O BASE1B3	Pattern 5, Exps 1-4 i n Seventh Epoch (1st Visit) (01) (5) Prime + Parallel Gro up 1-2 in Pattern 5, E xps 1-4 in Seventh E poch (1st Visit) (01)	1050 Secs (6300 Secs)	
								[==>(Pattern 1,1)]	[1]
								[==>(Pattern 1,2)]	[2]
								[==>(Pattern 2,1)]	[3]
								[==>(Pattern 2,2)]	[4]
								[==>(Pattern 3,1)]	[5]
	[==>(Pattern 3,2)]	[6]							
	2	ACS_F814 W	ANY	ACS/WFC, ACCUM, WFC	F814W		Pattern 5, Exps 1-4 i n Seventh Epoch (1st Visit) (01) (5) Prime + Parallel Gro up 1-2 in Pattern 5, E xps 1-4 in Seventh E poch (1st Visit) (01)	410 Secs X 2 (5262 Secs)	
								[==>426.0 Secs (Pattern 1,1, Copy 1)]	[1]
								[==>426.0 Secs (Pattern 1,1, Copy 2)]	
								[==>441.0 Secs (Pattern 1,2, Copy 1)]	[2]
								[==>441.0 Secs (Pattern 1,2, Copy 2)]	
								[==>441.0 Secs (Pattern 2,1, Copy 1)]	[3]
								[==>441.0 Secs (Pattern 2,1, Copy 2)]	
								[==>441.0 Secs (Pattern 2,2, Copy 1)]	[4]
								[==>441.0 Secs (Pattern 2,2, Copy 2)]	
								[==>441.0 Secs (Pattern 3,1, Copy 1)]	[5]
								[==>441.0 Secs (Pattern 3,1, Copy 2)]	
[==>441.0 Secs (Pattern 3,2, Copy 1)]								[6]	
[==>441.0 Secs (Pattern 3,2, Copy 2)]									
3	WFC3_F60 OLP	(1) SN-2011FE-UVI S	WFC3/UVIS, ACCUM, UVIS	F600LP		Pattern 5, Exps 1-4 i n Seventh Epoch (1st Visit) (01) (5) Prime + Parallel Gro up 3-4 in Pattern 5, E xps 1-4 in Seventh E poch (1st Visit) (01)	1800 Secs (11496 Secs)		
							[==>1821.0 Secs (Pattern 1,1)]	[1]	
							[==>1935.0 Secs (Pattern 1,2)]	[2]	
							[==>1935.0 Secs (Pattern 2,1)]	[3]	
							[==>1935.0 Secs (Pattern 2,2)]	[4]	
							[==>1935.0 Secs (Pattern 3,1)]	[5]	
[==>1935.0 Secs (Pattern 3,2)]	[6]								

Proposal 15192 - Seventh Epoch (1st Visit) (01) - Whimper of a Bang: Documenting the Final Days of the Nearby Type Ia Supernova ...

4	ACS_F814 W	ANY	ACS/WFC, ACCUM, WFC	F814W	Pattern 5, Exps 1-4 in Seventh Epoch (1st Visit) (01) (5) Prime + Parallel Group 3-4 in Pattern 5, Exps 1-4 in Seventh Epoch (1st Visit) (01)	400 Secs X 3 (8904 Secs)	
						[==>463.0 Secs (Pattern 1,1, Copy 1)]	[1]
						[==>463.0 Secs (Pattern 1,1, Copy 2)]	
						[==>463.0 Secs (Pattern 1,1, Copy 3)]	
						[==>501.0 Secs (Pattern 1,2, Copy 1)]	[2]
						[==>501.0 Secs (Pattern 1,2, Copy 2)]	
						[==>501.0 Secs (Pattern 1,2, Copy 3)]	
[==>501.0 Secs (Pattern 2,1, Copy 1)]	[3]						
[==>501.0 Secs (Pattern 2,1, Copy 2)]							
[==>501.0 Secs (Pattern 2,1, Copy 3)]							
[==>501.0 Secs (Pattern 2,2, Copy 1)]	[4]						
[==>501.0 Secs (Pattern 2,2, Copy 2)]							
[==>501.0 Secs (Pattern 2,2, Copy 3)]							
[==>501.0 Secs (Pattern 3,1, Copy 1)]	[5]						
[==>501.0 Secs (Pattern 3,1, Copy 2)]							
[==>501.0 Secs (Pattern 3,1, Copy 3)]							
[==>501.0 Secs (Pattern 3,2, Copy 1)]	[6]						
[==>501.0 Secs (Pattern 3,2, Copy 2)]							
[==>501.0 Secs (Pattern 3,2, Copy 3)]							

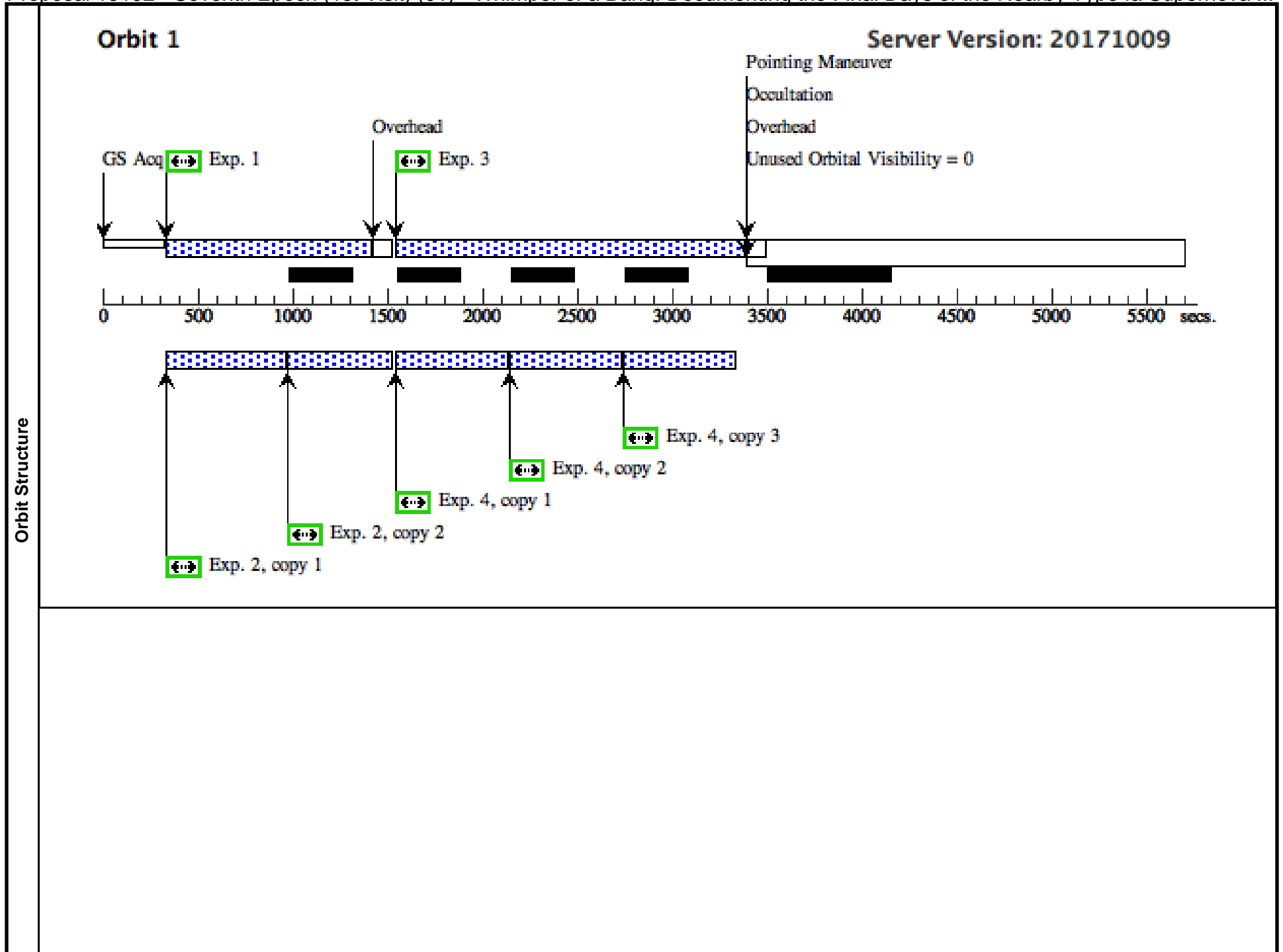

Orbit 2

Server Version: 20171009

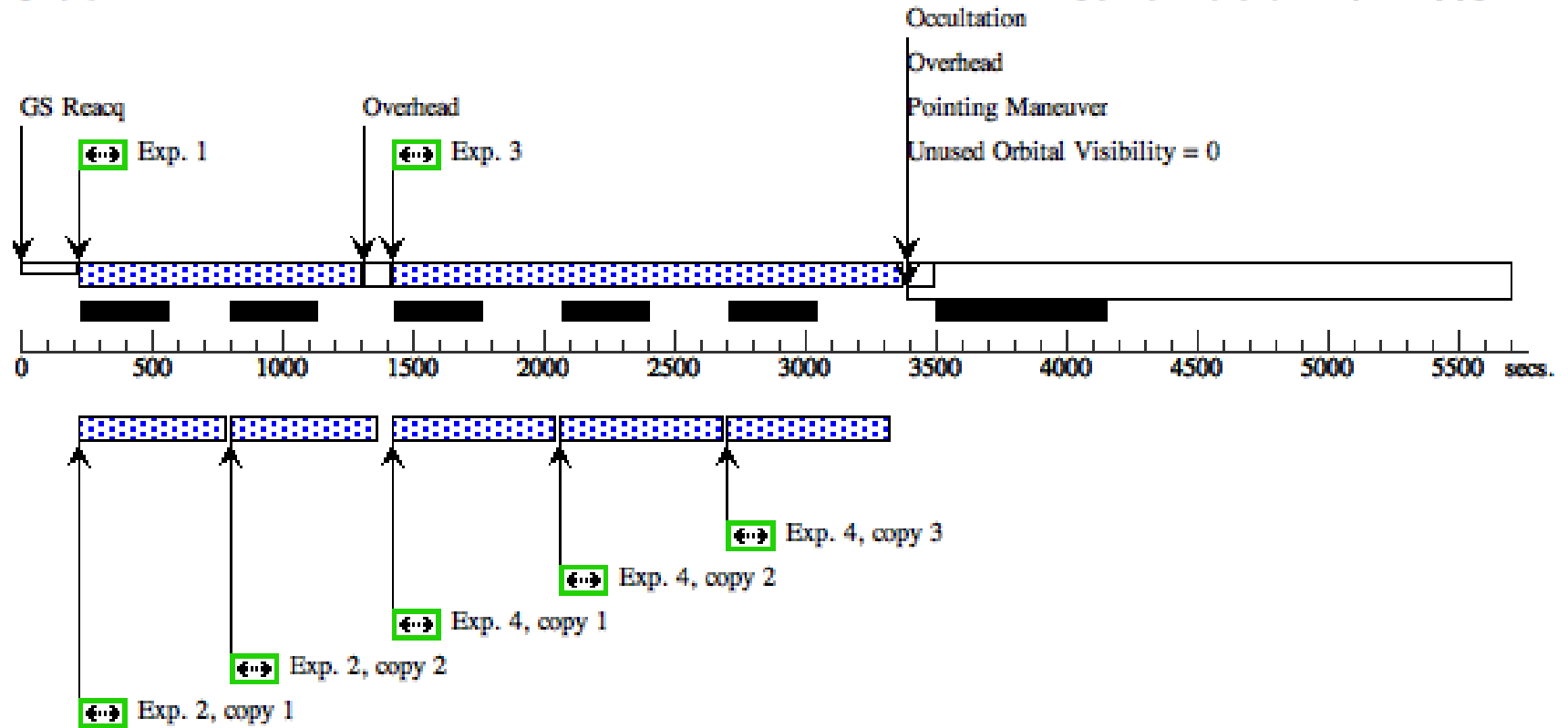

Orbit 3

Server Version: 20171009

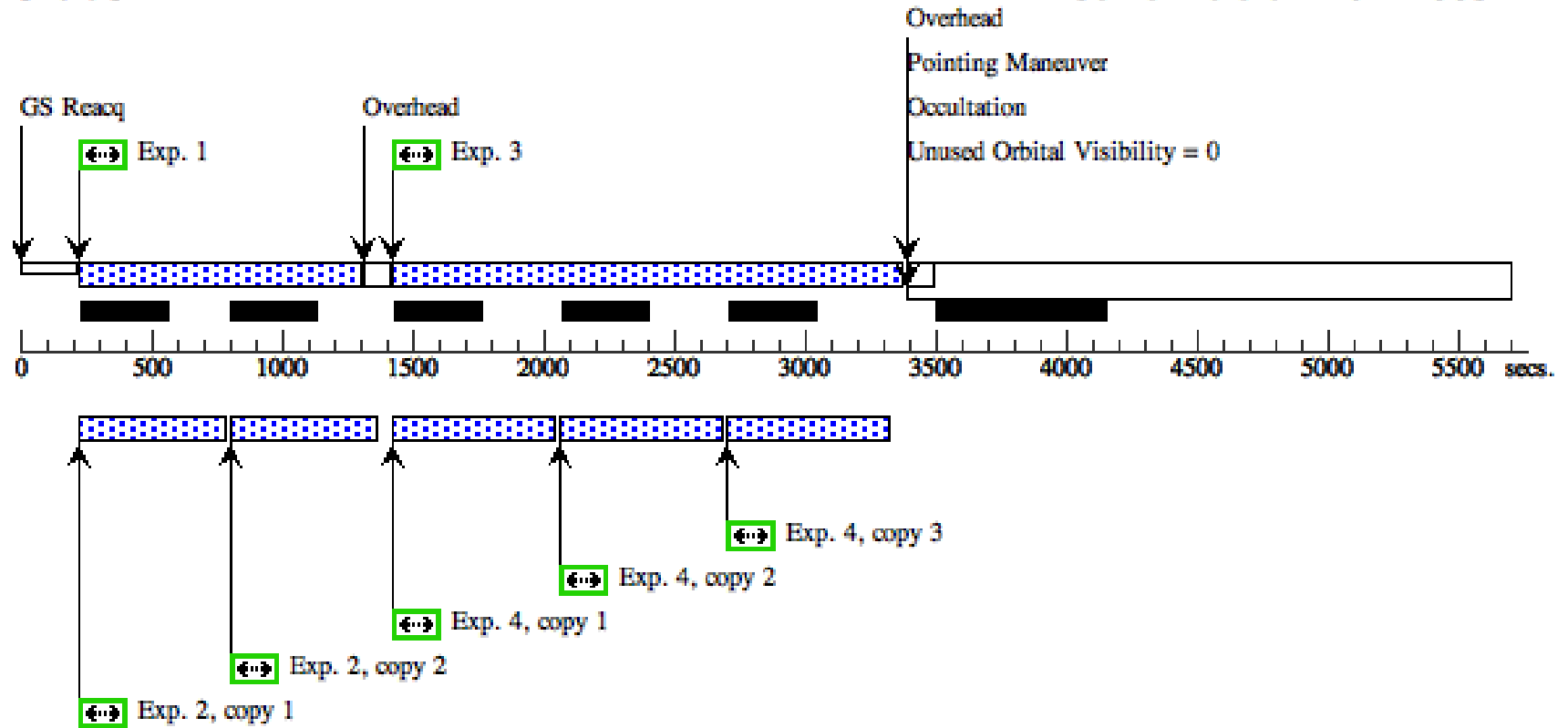

Orbit 4

Server Version: 20171009

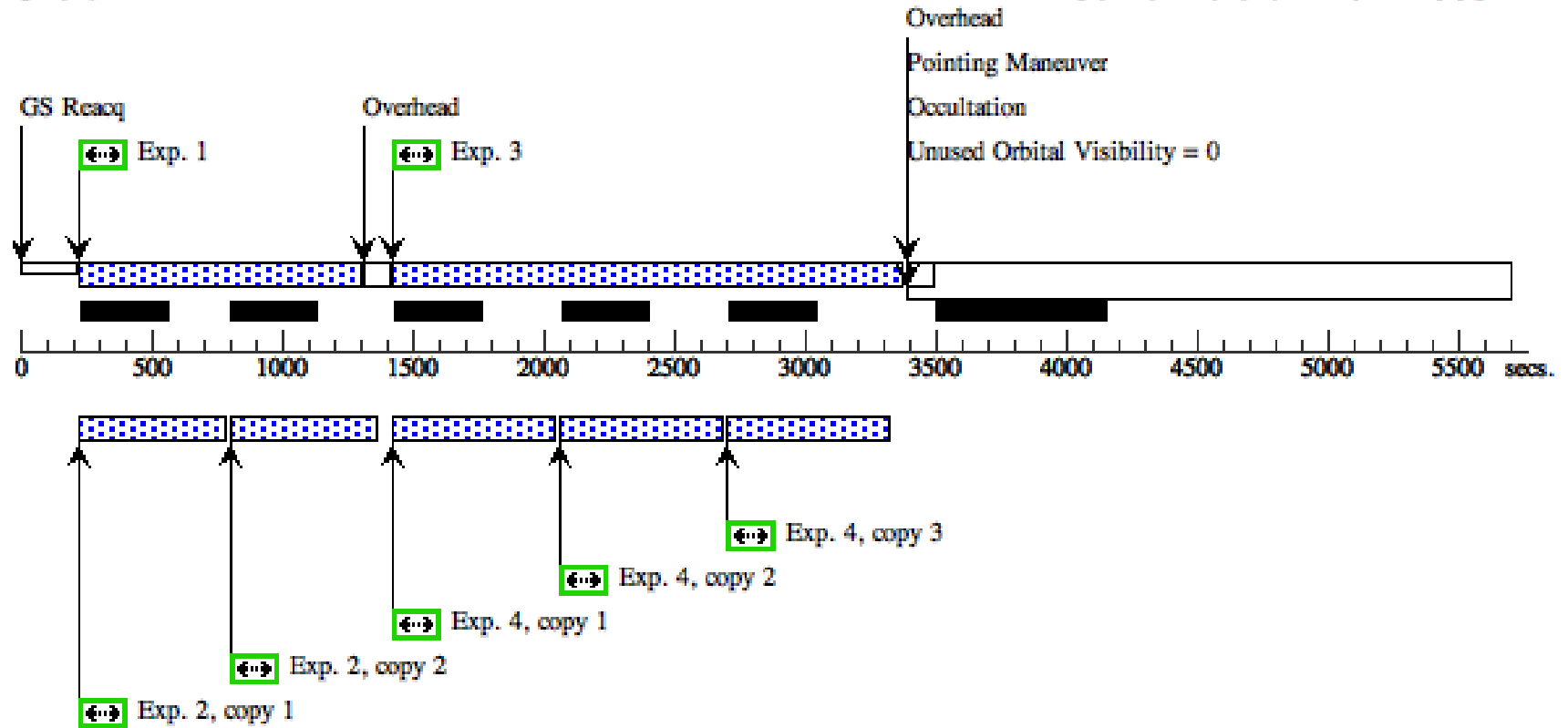

Orbit 5

Server Version: 20171009

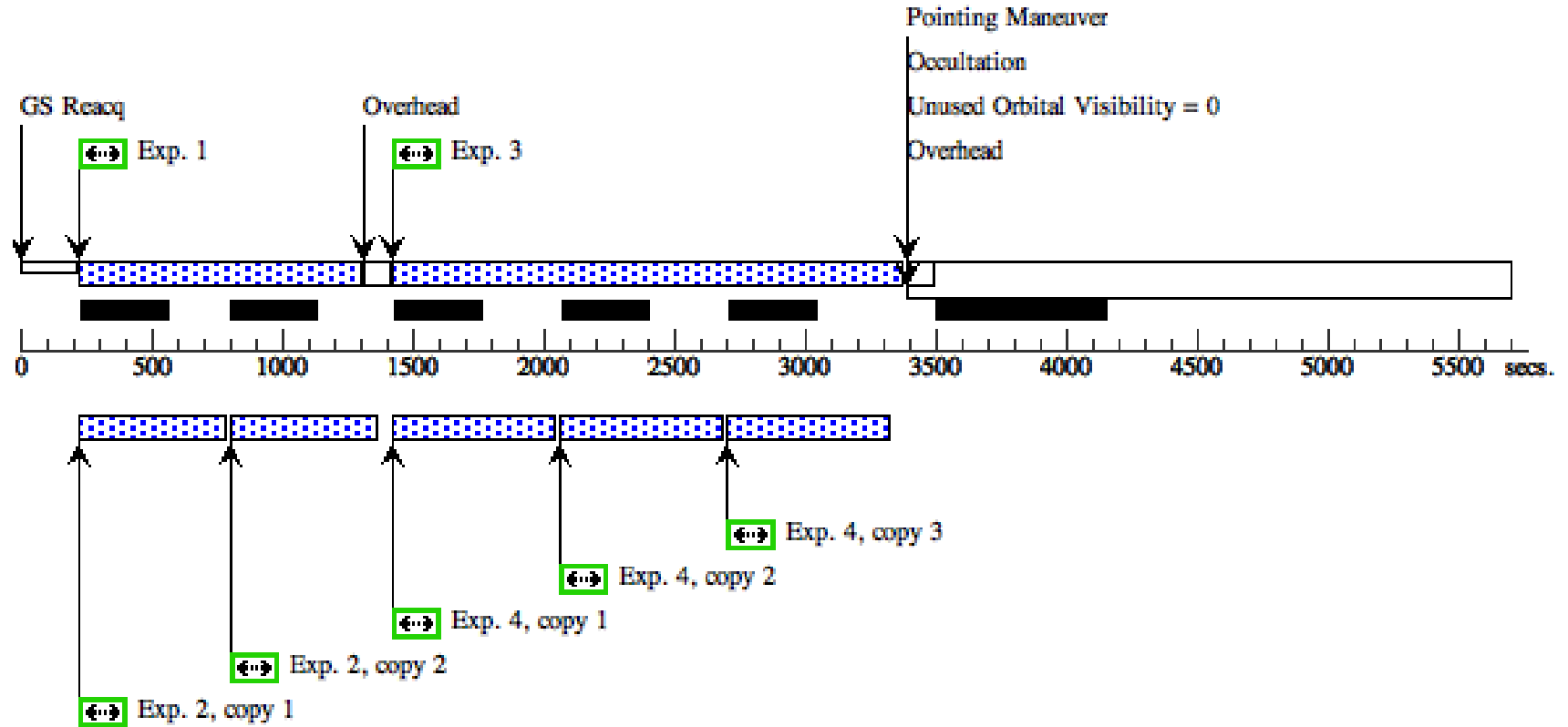

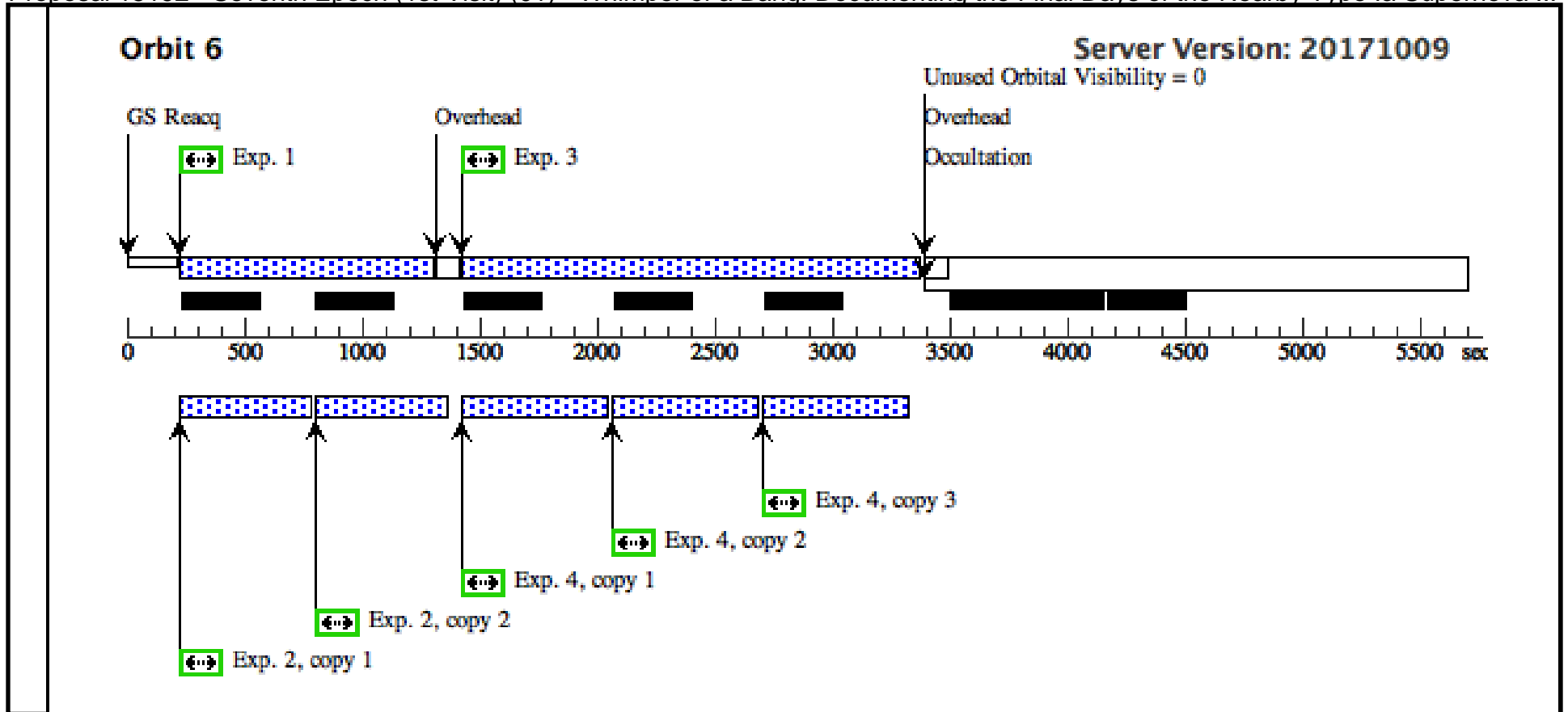

Proposal 15192 - Seventh Epoch (2nd Visit) (03) - Whimper of a Bang: Documenting the Final Days of the Nearby Type Ia Supernova ...

Thu Mar 08 02:00:29 GMT 2018

Visit	Proposal 15192, Seventh Epoch (2nd Visit) (03), implementation Diagnostic Status: No Diagnostics Scientific Instruments: WFC3/UVIS, ACS/WFC Special Requirements: ORIENT 205D TO 230 D; BETWEEN 01-MAR-2018:00:00:00 AND 31-MAR-2018:00:00:00; ON HOLD Comments: 13 orbits were not schedulable together, so we had to split the epoch into at least two visits. However, only up to 6 orbits are schedulable together, so we had to schedule three visits. On Hold Comments: Because of earth glow, orbits will need to be adjusted shortly before execution when sky brightness plots can be made.					
	Patterns	#	Primary Pattern	Secondary Pattern	Exposures	
(5)		Pattern Type=LINE Purpose=DITHER Number Of Points=3 Point Spacing=0.135 Line Spacing=	Coordinate Frame=POS-TARG Pattern Orientation=46.84 Angle Between Sides= Center Pattern=false	Pattern Type=LINE Purpose=DITHER Number Of Points=2 Point Spacing=0.0198 Line Spacing=	(1-2)	
Fixed Targets	#	Name	Target Coordinates	Targ. Coord. Corrections	Fluxes	Miscellaneous
	(1)	SN-2011FE-UVIS	RA: 14 03 14.3269 (210.8096954d) Dec: +54 16 22.93 (54.27304d) Equinox: J2000		V=27.5+/-1.0	Reference Frame: SIMBAD
Comments: This object was generated by the targetselector and retrieved from the SIMBAD database. Category=EXT-STAR Description=[SUPERNOVA TYPE IA]						

Proposal 15192 - Seventh Epoch (2nd Visit) (03) - Whimper of a Bang: Documenting the Final Days of the Nearby Type Ia Supernova ...

#	Label	Target	Config,Mode,Aperture	Spectral Els.	Opt. Params.	Special Reqs.	Groups	Exp. Time (Total)/[Actual Dur.]	Orbit	
Exposures	1	WFC3_F43 8W	(1) SN-2011FE-UVI S	WFC3/UVIS, ACCUM, UVIS	F438W	GS ACQ SCENARI O BASE1B3	Pattern 5, Exps 1-2 in Seventh Epoch (2nd Visit) (03) (5) Prime + Parallel Gro up 1-2 in Pattern 5, E xps 1-2 in Seventh E poch (2nd Visit) (03)	1400 Secs (8950 Secs)		
								[==>1444.0 Secs (Pattern 1,1)]	[1]	
								[==>1444.0 Secs (Pattern 1,2)]		
								[==>1515.0 Secs (Pattern 2,1)]	[2]	
								[==>1516.0 Secs (Pattern 2,2)]		
	[==>1515.0 Secs (Pattern 3,1)]	[3]								
	[==>1516.0 Secs (Pattern 3,2)]									
	2	ACS_F555 W	ANY	ACS/WFC, ACCUM, WFC	F555W			Pattern 5, Exps 1-2 in Seventh Epoch (2nd Visit) (03) (5) Prime + Parallel Gro up 1-2 in Pattern 5, E xps 1-2 in Seventh E poch (2nd Visit) (03)	410 Secs X 2 (7584 Secs)	
									[==>610.0 Secs (Pattern 1,1, Copy 1)]	[1]
									[==>610.0 Secs (Pattern 1,1, Copy 2)]	
[==>590.0 Secs (Pattern 1,2, Copy 1)]										
[==>590.0 Secs (Pattern 1,2, Copy 2)]										
[==>670.0 Secs (Pattern 2,1, Copy 1)]									[2]	
[==>670.0 Secs (Pattern 2,1, Copy 2)]										
[==>626.0 Secs (Pattern 2,2, Copy 1)]										
[==>626.0 Secs (Pattern 2,2, Copy 2)]										
[==>670.0 Secs (Pattern 3,1, Copy 1)]									[3]	
[==>670.0 Secs (Pattern 3,1, Copy 2)]										
[==>626.0 Secs (Pattern 3,2, Copy 1)]										
[==>626.0 Secs (Pattern 3,2, Copy 2)]										

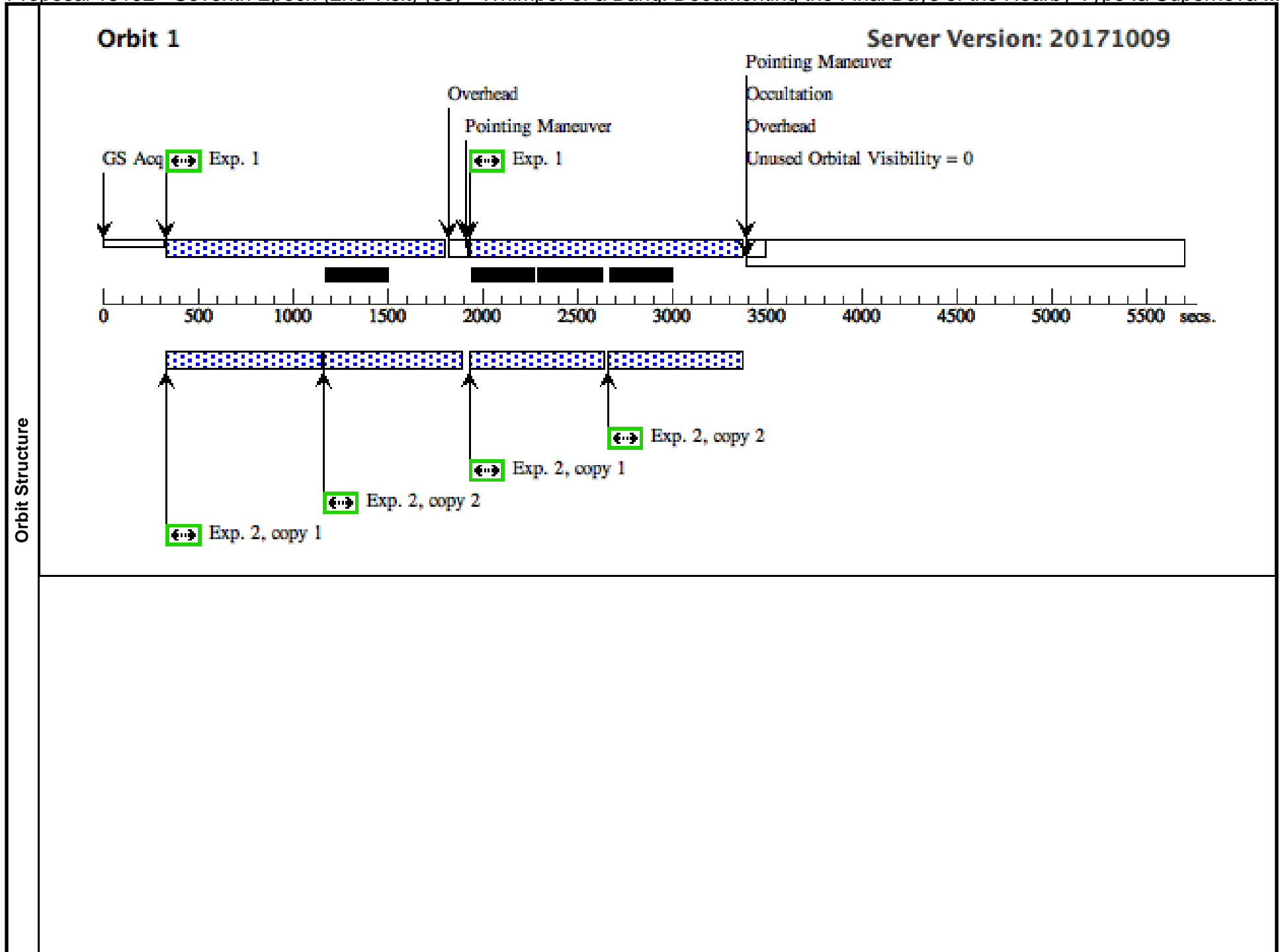

Orbit 2

Server Version: 20171009

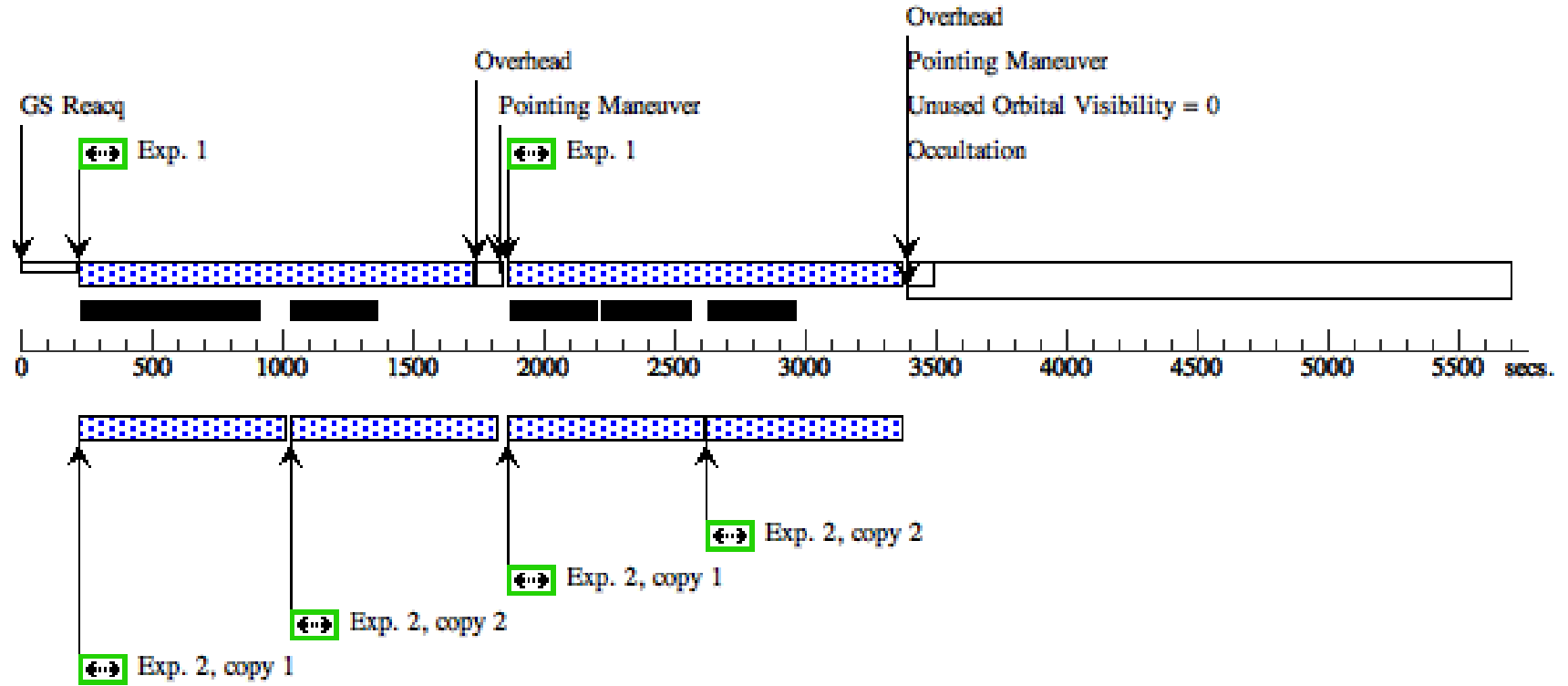

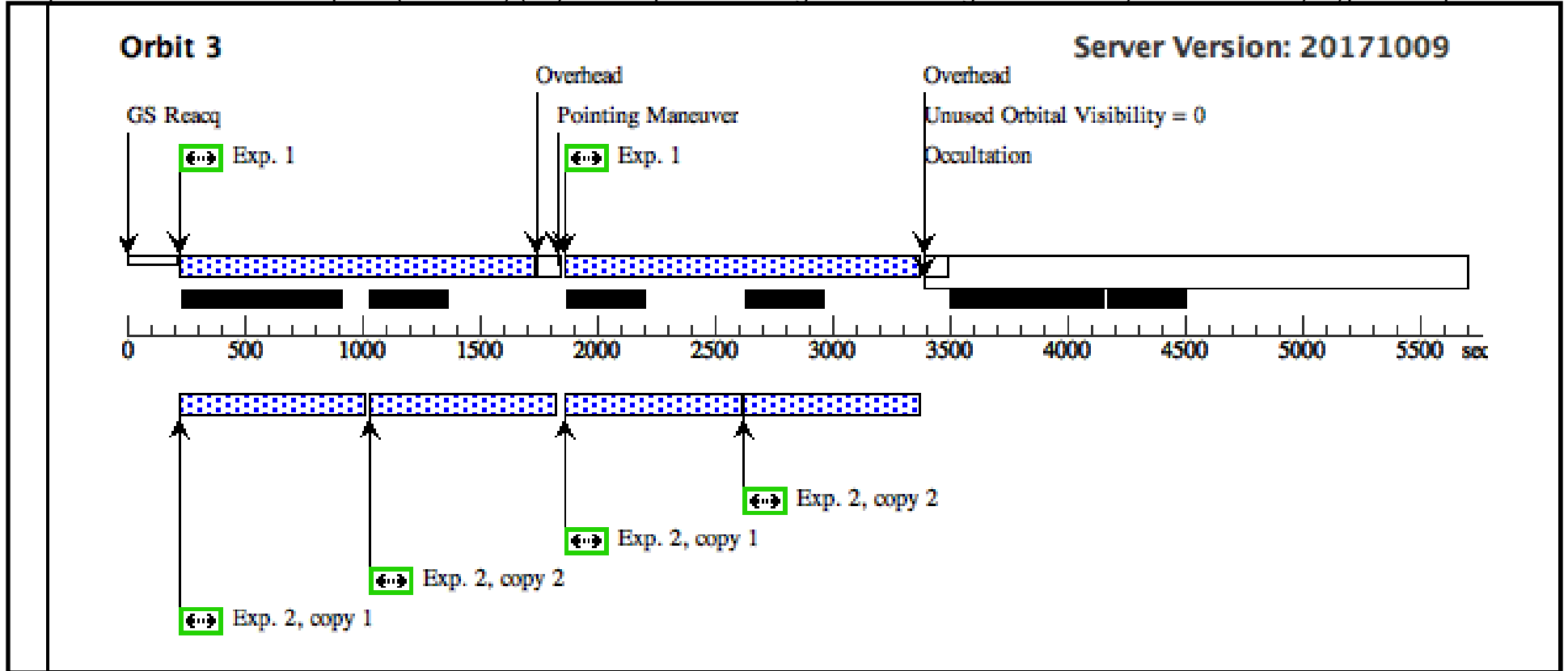

Proposal 15192 - Seventh Epoch (3rd Visit) (02) - Whimper of a Bang: Documenting the Final Days of the Nearby Type Ia Supernova ...

Thu Mar 08 02:00:29 GMT 2018

Visit	Proposal 15192, Seventh Epoch (3rd Visit) (02), implementation Diagnostic Status: Warning Scientific Instruments: WFC3/IR, ACS/WFC Special Requirements: ORIENT 205D TO 230 D; BETWEEN 01-MAR-2018:00:00:00 AND 31-MAR-2018:00:00:00; ON HOLD ; VISIBILITY INTERVAL 65.58 M Comments: 13 orbits were not schedulable together, so we had to split the epoch into at least two visits. However, only up to 6 orbits are schedulable together, so we had to schedule three visits. On Hold Comments: Because of earth glow, orbits will need to be adjusted shortly before execution when sky brightness plots can be made.														
	Diagnosics (Seventh Epoch (3rd Visit) (02)) Warning (Orbit Planner): PARALLELS SIGNIFICANTLY EXTEND ALIGNMENT TIME (Seventh Epoch (3rd Visit) (02)) Warning (Orbit Planner): PARALLELS SIGNIFICANTLY EXTEND ALIGNMENT TIME (Seventh Epoch (3rd Visit) (02)) Warning (Orbit Planner): PARALLELS SIGNIFICANTLY EXTEND ALIGNMENT TIME (Seventh Epoch (3rd Visit) (02)) Warning (Orbit Planner): PARALLELS SIGNIFICANTLY EXTEND ALIGNMENT TIME (Seventh Epoch (3rd Visit) (02)) Warning (Orbit Planner): PATTERN AND COORDINATED PARALLEL MISMATCH (Seventh Epoch (3rd Visit) (02)) Warning (Orbit Planner): PATTERN AND COORDINATED PARALLEL MISMATCH														
Patterns	<table border="1"> <thead> <tr> <th>#</th> <th>Primary Pattern</th> <th>Secondary Pattern</th> <th>Exposures</th> </tr> </thead> <tbody> <tr> <td>(2)</td> <td> Pattern Type=WFC3-IR-DITHER-BOX-MIN Purpose=DITHER Number Of Points=4 Point Spacing=0.572 Line Spacing=0.365 </td> <td> Coordinate Frame=POS-TARG Pattern Orientation=18.528 Angle Between Sides=74.653 Center Pattern=false </td> <td>(1-4)</td> </tr> </tbody> </table>	#	Primary Pattern	Secondary Pattern	Exposures	(2)	Pattern Type=WFC3-IR-DITHER-BOX-MIN Purpose=DITHER Number Of Points=4 Point Spacing=0.572 Line Spacing=0.365	Coordinate Frame=POS-TARG Pattern Orientation=18.528 Angle Between Sides=74.653 Center Pattern=false	(1-4)						
	#	Primary Pattern	Secondary Pattern	Exposures											
(2)	Pattern Type=WFC3-IR-DITHER-BOX-MIN Purpose=DITHER Number Of Points=4 Point Spacing=0.572 Line Spacing=0.365	Coordinate Frame=POS-TARG Pattern Orientation=18.528 Angle Between Sides=74.653 Center Pattern=false	(1-4)												
Fixed Targets <table border="1"> <thead> <tr> <th>#</th> <th>Name</th> <th>Target Coordinates</th> <th>Targ. Coord. Corrections</th> <th>Fluxes</th> <th>Miscellaneous</th> </tr> </thead> <tbody> <tr> <td>(2)</td> <td>SN-2011FE-IR</td> <td> RA: 14 03 6.0919 (210.7753829d) Dec: +54 16 26.53 (54.27404d) Equinox: J2000 </td> <td></td> <td>V=27.5+/-1.0</td> <td>Reference Frame: SIMBAD</td> </tr> </tbody> </table> Comments: This object was generated by the targetselector and retrieved from the SIMBAD database. Category=EXT-STAR Description=[SUPERNOVA TYPE IA]				#	Name	Target Coordinates	Targ. Coord. Corrections	Fluxes	Miscellaneous	(2)	SN-2011FE-IR	RA: 14 03 6.0919 (210.7753829d) Dec: +54 16 26.53 (54.27404d) Equinox: J2000		V=27.5+/-1.0	Reference Frame: SIMBAD
#	Name	Target Coordinates	Targ. Coord. Corrections	Fluxes	Miscellaneous										
(2)	SN-2011FE-IR	RA: 14 03 6.0919 (210.7753829d) Dec: +54 16 26.53 (54.27404d) Equinox: J2000		V=27.5+/-1.0	Reference Frame: SIMBAD										

Proposal 15192 - Seventh Epoch (3rd Visit) (02) - Whimper of a Bang: Documenting the Final Days of the Nearby Type Ia Supernova ...

Exposures	#	Label	Target	Config,Mode,Aperture	Spectral Els.	Opt. Params.	Special Reqs.	Groups	Exp. Time (Total)/[Actual Dur.]	Orbit
	1	WFC3-F110 W	(2) SN-2011FE-IR	WFC3/IR, MULTIACCUM, IR	F110W	SAMP-SEQ=SPARS 200; NSAMP=8	GS ACQ SCENARI O BASE1B3	Pattern 2, Exps 1-4 i n Seventh Epoch (3r d Visit) (02) (2)	1402.93276 Secs (5611.731 Secs)	
									[==>(Pattern 1)]	[1]
									[==>(Pattern 2)]	[2]
									Prime + Parallel Gro up 1-2 in Pattern 2, E xps 1-4 in Seventh E poch (3rd Visit) (02)	[==>(Pattern 3)]
									[==>(Pattern 4)]	[4]
	2	ACS_F658 N	ANY	ACS/WFC, ACCUM, WFC	F658N			Pattern 2, Exps 1-4 i n Seventh Epoch (3r d Visit) (02) (2)	1490 Secs (5770 Secs)	
									[==>1336.0 Secs (Pattern 1)]	[1]
									[==>1478.0 Secs (Pattern 2)]	[2]
									Prime + Parallel Gro up 1-2 in Pattern 2, E xps 1-4 in Seventh E poch (3rd Visit) (02)	[==>1478.0 Secs (Pattern 3)]
								[==>1478.0 Secs (Pattern 4)]	[4]	
3	WFC3-F160 W	(2) SN-2011FE-IR	WFC3/IR, MULTIACCUM, IR	F160W	SAMP-SEQ=SPARS 200; NSAMP=11		Pattern 2, Exps 1-4 i n Seventh Epoch (3r d Visit) (02) (2)	2002.932961 Secs (8011.732 Secs)		
								[==>(Pattern 1)]	[1]	
								[==>(Pattern 2)]	[2]	
								Prime + Parallel Gro up 3-4 in Pattern 2, E xps 1-4 in Seventh E poch (3rd Visit) (02)	[==>(Pattern 3)]	[3]
								[==>(Pattern 4)]	[4]	
4	ACS_F435 W	ANY	ACS/WFC, ACCUM, WFC	F435W			Pattern 2, Exps 1-4 i n Seventh Epoch (3r d Visit) (02) (2)	1000 Secs (7423 Secs)		
								[==>1855.0 Secs (Pattern 1)]	[1]	
								[==>1856.0 Secs (Pattern 2)]	[2]	
								Prime + Parallel Gro up 3-4 in Pattern 2, E xps 1-4 in Seventh E poch (3rd Visit) (02)	[==>1856.0 Secs (Pattern 3)]	[3]
								[==>1856.0 Secs (Pattern 4)]	[4]	

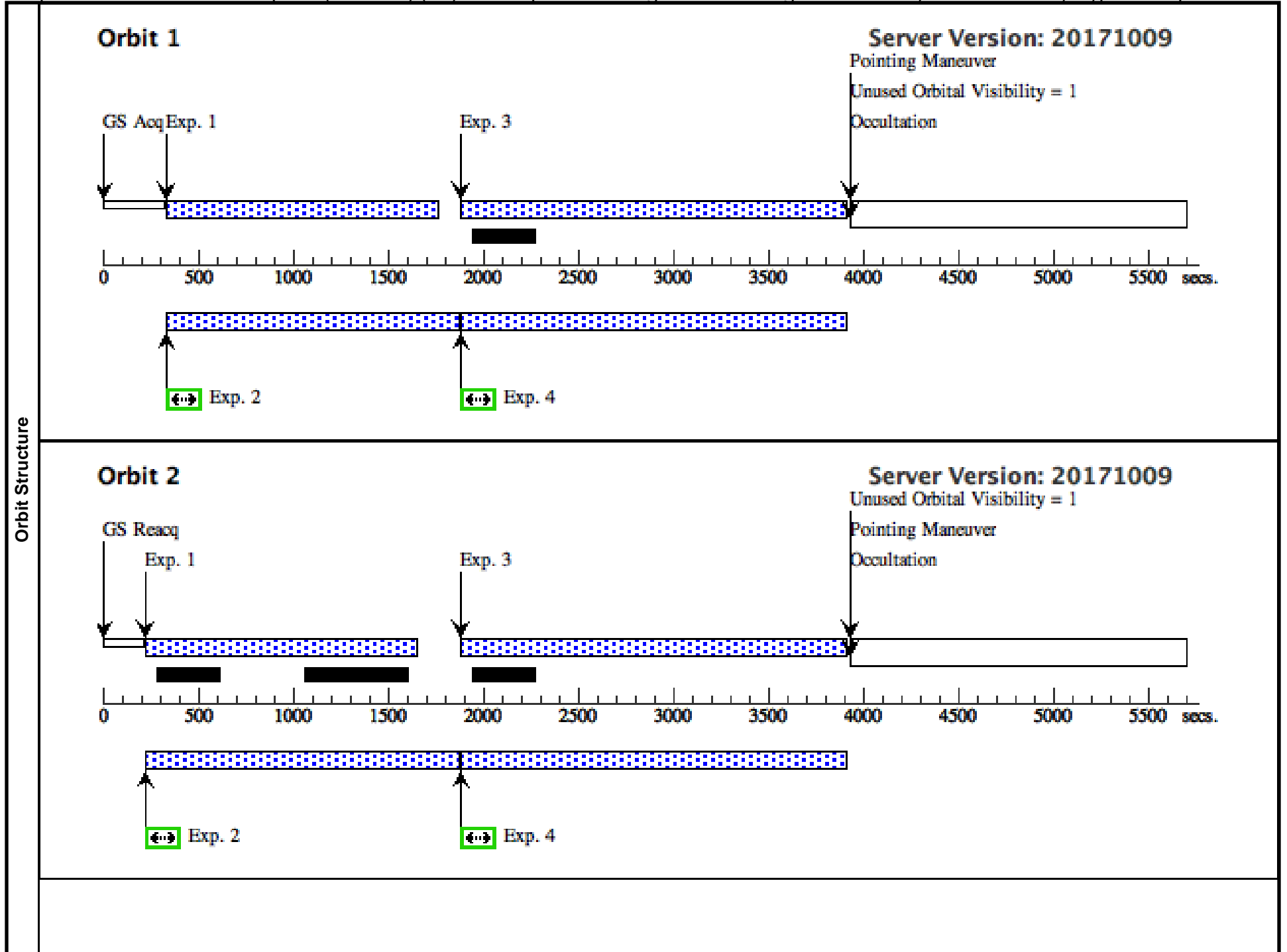

Orbit 3

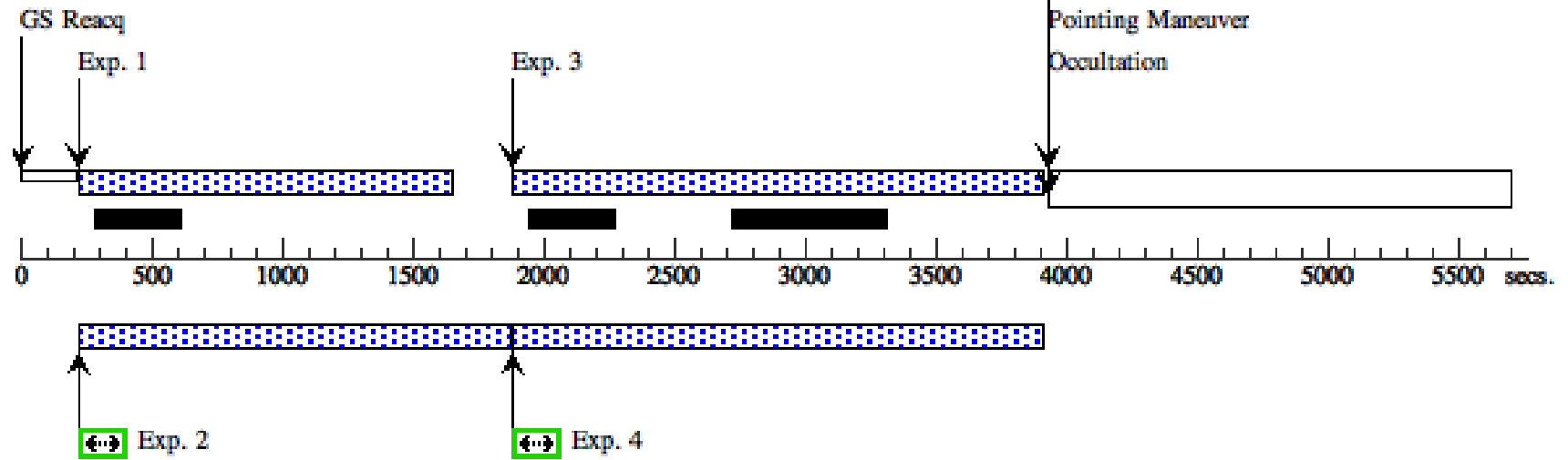

Orbit 4

