



15300 - Ecliptic-poles Stellar Survey (EclipSS)

Cycle: 25, Proposal Category: GO

(UV Initiative)

(Availability Mode: SUPPORTED)

INVESTIGATORS

<i>Name</i>	<i>Institution</i>	<i>E-Mail</i>
Dr. Thomas R. Ayres (PI) (Contact)	University of Colorado at Boulder	thomas.ayres@colorado.edu

VISITS

<i>Visit</i>	<i>Targets used in Visit</i>	<i>Configurations used in Visit</i>	<i>Orbits Used</i>	<i>Last Orbit Planner Run</i>	<i>OP Current with Visit?</i>
01	(1) HD156559	COS/FUV COS/NUV	1	13-Dec-2018 17:01:13.0	yes
02	(2) HD39755	COS/FUV COS/NUV	1	13-Dec-2018 17:01:15.0	yes
03	(3) HD156389	COS/FUV COS/NUV	1	13-Dec-2018 17:01:16.0	yes
04	(4) HD24636	COS/FUV COS/NUV	1	13-Dec-2018 17:01:17.0	yes
05	(5) HD21166	COS/FUV COS/NUV	1	13-Dec-2018 17:01:18.0	yes
06	(6) HD56737	COS/FUV COS/NUV	1	13-Dec-2018 17:01:19.0	yes
07	(7) HD154956	COS/FUV COS/NUV	1	13-Dec-2018 17:01:20.0	yes

Proposal 15300 (STScI Edit Number: 4, Created: Thursday, December 13, 2018 at 5:02:06 PM Eastern Standard Time) - Overview

<i>Visit</i>	<i>Targets used in Visit</i>	<i>Configurations used in Visit</i>	<i>Orbits Used</i>	<i>Last Orbit Planner Run</i>	<i>OP Current with Visit?</i>
08	(8) HD53658	COS/FUV COS/NUV	1	13-Dec-2018 17:01:21.0	yes
09	(9) HD28481	COS/FUV COS/NUV	1	13-Dec-2018 17:01:23.0	yes
10	(10) HD22359	COS/FUV COS/NUV	1	13-Dec-2018 17:01:24.0	yes
11	(11) HD29255	COS/FUV COS/NUV	1	13-Dec-2018 17:01:25.0	yes
51	(11) HD29255	COS/FUV COS/NUV	1	16-Apr-2018 14:44:08.0	yes
12	(12) HD165700	COS/FUV COS/NUV	1	13-Dec-2018 17:01:26.0	yes
13	(13) HD185239	COS/FUV COS/NUV	1	13-Dec-2018 17:01:27.0	yes
14	(14) HD168093	COS/FUV COS/NUV	1	13-Dec-2018 17:01:28.0	yes
15	(15) HD20052	COS/FUV COS/NUV	1	13-Dec-2018 17:01:29.0	yes
16	(16) HD180712	COS/FUV COS/NUV	1	13-Dec-2018 17:01:31.0	yes
17	(17) HD159329	COS/FUV COS/NUV	1	13-Dec-2018 17:01:32.0	yes
18	(18) HD36767	COS/FUV COS/NUV	1	13-Dec-2018 17:01:33.0	yes
19	(19) HD187876	COS/FUV COS/NUV	1	13-Dec-2018 17:01:34.0	yes
20	(20) HD146044	COS/FUV COS/NUV	1	13-Dec-2018 17:01:35.0	yes

Proposal 15300 (STScI Edit Number: 4, Created: Thursday, December 13, 2018 at 5:02:06 PM Eastern Standard Time) - Overview

<i>Visit</i>	<i>Targets used in Visit</i>	<i>Configurations used in Visit</i>	<i>Orbits Used</i>	<i>Last Orbit Planner Run</i>	<i>OP Current with Visit?</i>
21	(21) HD51929	COS/FUV COS/NUV	1	13-Dec-2018 17:01:36.0	yes
22	(22) HD28701	COS/FUV COS/NUV	1	13-Dec-2018 17:01:37.0	yes
23	(23) HD172669	COS/FUV COS/NUV	1	13-Dec-2018 17:01:38.0	yes
24	(24) HD150706	COS/FUV COS/NUV	1	13-Dec-2018 17:01:39.0	yes
25	(25) HD62850	COS/FUV COS/NUV	1	13-Dec-2018 17:01:40.0	yes
26	(26) HD24293	COS/FUV COS/NUV	1	13-Dec-2018 17:01:41.0	yes
27	(27) HD64184	COS/FUV COS/NUV	1	13-Dec-2018 17:01:42.0	yes
28	(28) HD73744	COS/FUV COS/NUV	1	13-Dec-2018 17:01:43.0	yes
29	(29) HD147231	COS/FUV COS/NUV	1	13-Dec-2018 17:01:44.0	yes
30	(30) HD28471	COS/FUV COS/NUV	1	13-Dec-2018 17:01:45.0	yes
31	(31) HD144061	COS/FUV COS/NUV	1	13-Dec-2018 17:01:46.0	yes
32	(32) HD146868	COS/FUV COS/NUV	1	13-Dec-2018 17:01:47.0	yes
33	(33) HD137826	COS/FUV COS/NUV	1	13-Dec-2018 17:01:48.0	yes
34	(34) HD32778	COS/FUV COS/NUV	1	13-Dec-2018 17:01:50.0	yes

Proposal 15300 (STScI Edit Number: 4, Created: Thursday, December 13, 2018 at 5:02:06 PM Eastern Standard Time) - Overview

<i>Visit</i>	<i>Targets used in Visit</i>	<i>Configurations used in Visit</i>	<i>Orbits Used</i>	<i>Last Orbit Planner Run</i>	<i>OP Current with Visit?</i>
35	(35) HD34297	COS/FUV COS/NUV	1	13-Dec-2018 17:01:51.0	yes
36	(36) HD199476	COS/FUV COS/NUV	1	13-Dec-2018 17:01:52.0	yes
37	(37) HD55720	COS/FUV COS/NUV	1	13-Dec-2018 17:01:53.0	yes
38	(38) HD63765	COS/FUV COS/NUV	1	13-Dec-2018 17:01:54.0	yes
39	(39) HD161897	COS/FUV COS/NUV	1	13-Dec-2018 17:01:55.0	yes
40	(40) HD201651	COS/FUV COS/NUV	1	13-Dec-2018 17:01:56.0	yes
41	(41) HD39194	COS/FUV COS/NUV	1	13-Dec-2018 17:01:57.0	yes
42	(42) HD51608	COS/FUV COS/NUV	1	13-Dec-2018 17:01:58.0	yes
43	(43) HD151541	COS/FUV COS/NUV	1	13-Dec-2018 17:01:59.0	yes
44	(44) HD47252	COS/FUV COS/NUV	1	13-Dec-2018 17:02:00.0	yes
45	(45) HD202123	COS/FUV COS/NUV	1	13-Dec-2018 17:02:01.0	yes
46	(46) HD41004	COS/FUV COS/NUV	1	13-Dec-2018 17:02:02.0	yes
47	(47) HD42286	COS/FUV COS/NUV	1	13-Dec-2018 17:02:03.0	yes
48	(48) HD38459	COS/FUV COS/NUV	1	13-Dec-2018 17:02:04.0	yes

<i>Visit</i>	<i>Targets used in Visit</i>	<i>Configurations used in Visit</i>	<i>Orbits Used</i>	<i>Last Orbit Planner Run</i>	<i>OP Current with Visit?</i>
49	(49) HD30501	COS/FUV COS/NUV	1	13-Dec-2018 17:02:05.0	yes
53	(30) HD28471	COS/FUV COS/NUV	1	13-Dec-2018 17:02:06.0	yes

51 Total Orbits Used

ABSTRACT

BACKGROUND: Now and in coming years, a number of orbiting observatories will be scanning the skies for astrometry (Gaia), transiting exoplanets (TESS), and high-energy sources (eROSITA). A key characteristic of these surveys is their high degree of exposure in the ecliptic polar regions, north and south; a natural consequence of their preferred scanning orientation. Further, JWST, although not a scanning instrument, also holds the ecliptic poles in special regard because they are accessible at all times ("continuous viewing zones"), a key advantage for exo-planet studies.

THIS PROPOSAL: Record FUV spectra, with COS G130M, of a well-defined sample of sunlike dwarfs (F2V-K2V) at the ecliptic poles to take advantage of the enhanced, wholistic information concerning rotation periods, sizes, masses, metallicities, ages, activity levels, and coronal properties that will be available for bright e-polar stars over the next few years. There is a sweet spot at about 8th magnitude where sunlike stars are not too bright for TESS, bright enough for eROSITA, and just right for COS. The G130M channel captures a wide range of ionization states, especially of Si, N, O, and C; the hydrogen Lyman-alpha emission; and also coronal forbidden transitions of Fe XII (124 nm) and Fe XXI (135 nm); altogether reflecting gas temperatures from 10,000 K to 10 MK in the magnetically disturbed stellar outer atmospheres. The combined photometric (starspots), asteroseismic, FUV, and X-ray measurements will inform community-wide efforts to explore stellar activity and its underlying magnetic machine, the Dynamo. This is a unique opportunity, and one -- like a solar eclipse -- too good to pass up.

OBSERVING DESCRIPTION

The EclipSS project -- Ecliptic poles Stellar Survey -- aims to collect FUV spectra (115-143 nm), from HST's ultra-sensitive Cosmic Origins Spectrograph (COS), of a sample of 49 F2-K2 dwarf stars in the North and South ecliptic polar regions, to further advance studies of magnetic activity among cool Main sequence stars analogous to the Sun. The ecliptic poles occupy favored places for several current and up-coming astronomical survey satellites, including Gaia (astrometry), TESS (exoplanets and asteroseismology), and eROSITA (coronal X-rays). These

Proposal 15300 (STScI Edit Number: 4, Created: Thursday, December 13, 2018 at 5:02:06 PM Eastern Standard Time) - Overview

instruments scan along lines of ecliptic longitude, and thus accumulate their deepest exposures in the ecliptic polar regions. The 49 EclipSS targets were down-selected from a larger sample of potential candidates to fall in a favorable range of visual magnitudes (not too bright for TESS, but bright enough for eROSITA and COS), ostensibly single stars (a few are known visual binaries of nearly equal components [HD156389, HD22359] with separations smaller than half the COS PSA radius; or with a much fainter secondary [HD144061, HD41004] that likely will not be visible), and not have any other bright star close by (important for 0.5'-resolution eROSITA). The targets are listed in Table 1.

TABLE 1. EclipSS Targets

```

=====
# Name      RA    Dec    V  SpTp  B-V  d  GAL RASS
      (hms)  (dms) (mag) Lum (mag) (pc) (logLx)
-----
01 HD156559 17 14 43 +58 23 02 7.89 F2V 0.37 84 Y 28.72
02 HD39755  05 50 18 -62 04 48 7.82 F2V 0.38 79 Y 28.95
03 HD156389 17 14 06 +56 08 01 7.77 F2V 0.45 86 Y -- AB 0.4" PA=319 dHp=0.28
04 HD24636  03 48 11 -74 41 38 7.12 F3V 0.38 57 Y 28.93
05 HD21166  03 18 57 -73 59 10 7.23 F3V 0.39 73 Y --
06 HD56737  07 14 22 -61 04 11 7.16 F3V 0.41 59 Y --
07 HD154956 17 05 47 +53 45 03 8.29 F5V 0.46 93 Y --
08 HD53658  07 01 05 -65 42 23 7.34 F6V 0.41 57 Y --
09 HD28481  04 26 38 -53 42 15 8.30 F6V 0.44 100 Y --
10 HD22359  03 32 43 -60 34 27 7.65 F6V 0.46 68 Y -- AB 0.7" PA=85 dHp=0.35
11 HD29255  04 29 58 -72 16 31 8.36 F6V 0.48 86 Y --
12 HD165700 18 04 00 +55 16 23 7.80 F8V 0.41 89 Y 28.71
13 HD185239 19 34 51 +57 46 21 8.16 F8V 0.41 81 Y 28.49
14 HD168093 18 15 20 +50 58 16 7.66 F8V 0.53 54 Y --
15 HD20052  03 10 08 -62 21 27 8.34 F8V 0.54 79 Y --
16 HD180712 19 14 01 +59 33 06 7.99 F8V 0.58 45 Y 28.07
17 HD159329 17 29 44 +63 51 09 7.67 F9V 0.52 46 Y --
18 HD36767  05 25 19 -75 41 32 7.18 F9V 0.53 36 Y --

```

Proposal 15300 (STScI Edit Number: 4, Created: Thursday, December 13, 2018 at 5:02:06 PM Eastern Standard Time) - Overview

19	HD187876	19 49 12	+57 24 33	7.76	G0V	0.56	47	N	--	
20	HD146044	16 10 47	+59 40 31	8.13	G0V	0.68	43	Y	--	
21	HD51929	06 55 53	-56 56 32	7.43	G2V	0.59	38	N	--	
22	HD28701	04 25 45	-69 59 37	7.87	G2V	0.61	44	Y	--	
23	HD172669	18 36 23	+66 54 47	7.60	G3V	0.58	36	Y	28.12	
24	HD150706	16 31 17	+79 47 23	7.02	G3V	0.60	28	Y	28.90	
25	HD62850	07 42 36	-59 17 50	7.19	G3V	0.64	33	N	29.22	
26	HD24293	03 48 01	-64 50 11	7.85	G3V	0.65	43	Y	--	
27	HD64184	07 49 26	-59 22 51	7.52	G3V	0.67	33	N	--	
28	HD73744	08 32 15	-76 55 43	7.61	G5V	0.60	35	N	--	
29	HD147231	16 14 50	+70 55 46	7.90	G5V	0.63	41	Y	--	
30	HD28471	04 25 09	-64 04 48	7.91	G5V	0.65	44	Y	--	
31	HD144061	15 58 21	+70 53 40	7.29	G5V	0.66	29	N	--	AB 2.3" PA=34 dV=5.0
32	HD146868	16 14 57	+60 40 11	7.69	G5V	0.66	30	Y	--	
33	HD137826	15 24 04	+66 33 14	8.72	G6V	0.69	49	Y	28.38	
34	HD32778	05 02 17	-56 04 49	7.02	G7V	0.63	22	Y	--	
35	HD34297	05 06 35	-77 34 02	7.31	G8V	0.66	40	Y	--	
36	HD199476	20 51 44	+74 46 49	7.81	G8V	0.70	30	Y	--	
37	HD55720	07 11 31	-49 25 27	7.47	G8V	0.77	28	N	--	
38	HD63765	07 47 49	-54 15 50	8.10	G9V	0.75	32	N	--	
39	HD161897	17 41 06	+72 25 13	7.61	K0V	0.72	30	N	28.26	
40	HD201651	21 06 56	+69 40 28	8.20	K0V	0.74	32	N	--	
41	HD39194	05 44 31	-70 08 36	8.07	K0V	0.76	26	N	--	
42	HD51608	06 54 51	-55 15 33	8.17	K0V	0.77	35	Y	--	
43	HD151541	16 42 38	+68 06 07	7.56	K1V	0.76	24	Y	--	
44	HD47252	06 31 56	-68 42 35	8.27	K1V	0.79	28	Y	--	
45	HD202123	21 08 40	+73 41 48	8.70	K1V	0.82	32	Y	--	
46	HD41004	05 59 49	-48 14 22	8.65	K1V	0.84	37	Y	29.24	AB 0.5" dHp=3.7 PA=176
47	HD42286	06 06 03	-59 32 35	8.47	K1V	0.84	25	Y	--	

48 HD38459 05 43 26 -47 49 22 8.50 K1V 0.87 37 Y 28.56

49 HD30501 04 45 38 -50 04 27 7.58 K2V 0.88 21 Y 27.98 90 Mjup companion

GAL= Galax; RASS= Rosat all-sky survey; log(Lx) in erg/s

The observing plan is similar for all the targets, requiring a single COS orbit each. Following the Guide Star acquisition, an NUV imaging ACQ is carried out, using the BOA and either Mirror A or B depending on the target brightness. The NUV exposure times range from about 10s (Mirror A) to about 200s (Mirror B). The NUV ACQ is followed by exposures with G130M-1223 at FP-POS 3 and 4 (107-121 nm [Segment B], 122-136 nm [A]), then G130M-1291, again at FP-POS 3 and 4 (113-128 nm [B], 129-143 [A]). Each sub-exposure was assigned the same duration, about 520 s for the typical target. The 113-136 nm region is (mostly, except for Ly-alpha) covered by all four exposures, so that fixed pattern noise would be effectively mitigated for that interval.

SAFETY ISSUES. Although the targets have not been observed previously in the FUV (e.g., by IUE), they are optically faint enough that the normal chromospheric (O I 130 nm, C II 133 nm) and "sub-coronal" lines (N V 124 nm, Si IV 139 nm) also will be faint, so that detector safety concerns should not be an issue. To test this, ETC simulations were carried out using an "extreme" FUV reference spectrum.

The test spectrum was constructed by first collecting STIS FUV tracings, from the StarCAT catalog, of thirteen representative dwarf stars covering the same spectral type range as the EclipSS targets; interpolating these onto a reference wavelength scale correcting for radial velocities and after adjusting the flux scales to V=0; then taking the average of the top three values at each wavelength. The constituent stars were chosen such that their ROSAT All-Sky Survey (RASS) luminosities were in the same (upper) range as recorded for the 14 EclipSS targets having RASS detections (the rest are upper limits). The final co-added spectrum is dominated by the 3 reference StarCAT dwarfs with log(Lx)>29 (erg/s). The "extreme" FUV spectrum then was adjusted to V=7.2 mag, which is the value of the brightest of the two EclipSS targets with log(Lx)>29 (HD62850: 29.22).

The reference spectrum is typical of a moderately active dwarf star, like those of the Hyades cluster (already safely observed by COS) but still far below the most active G dwarfs, such as the young (50 Myr) solar analog EK Draconis (which has log(Lx)>30). Most of the EclipSS targets (i.e., those with only RASS upper limits: log(Lx)<28), will have much fainter FUV energy distributions than that of the test spectrum. Further, the EclipSS targets were specifically drawn from spectral classes (F2-K2) that are not known for large flare events (unlike the early/mid-M dwarfs), and long-term FUV variability (say, due to activity cycles) is observed to be modest in such stars as well.

Proposal 15300 (STScI Edit Number: 4, Created: Thursday, December 13, 2018 at 5:02:06 PM Eastern Standard Time) - Overview

The only potential spectral safety issue identified in the ETC simulations involves the brightest feature in cool-star FUV spectra: H I Ly-alpha. The ETC run (COS.sp.1005139) for the extreme FUV spectrum at Ly-alpha predicts a brightest pixel of 0.28 cps, of which most (60%) is contributed by the sky geocoronal background assumed by the simulation. This is 4x below the local count rate limit (for the star-alone contribution of 0.11 cps, on top of the 0.17 cps geocoronal), especially considering that the Ly-alpha emission of the generally more distant EclipSS targets likely is more degraded by ISM absorption than the closer StarCAT stars that comprise the reference FUV spectrum.

Further, the "extreme" ETC simulation refers to just the most active (in terms of L_x) of the EclipSS stars, HD62850; all the other targets have lower $\log(L_x)$, or similar $\log(L_x)$ but fainter V magnitude, and thus weaker expected Ly-alpha. If, however, it is deemed that Ly-alpha observations of the most active of the EclipSS targets are too risky, then "Plan B" would be to observe with G130M-1223 A+B, but then turn off side B for the subsequent G130M-1291 exposures. The reconfiguration, however, "costs" about 350s, so would result in a loss of about 16% exposure. Another possibility would be to use segment A exclusively for 1223 and 1291, which would not give up any exposure time, but would lose key diagnostics below Ly-alpha, such as Si III 120 nm and C III 117 nm, so is not preferred. Indeed, recording Ly-alpha would be an important objective in itself, so the program as proposed is the best option scientifically, with essentially no risk.

Finally, in terms of background FUV objects that might be included in the COS PSA, most of the targets (38 of the 49) have Galex detections, all with the (low) intensity expected from the cool star itself, which rules out background sources for those cases. Further, some of the "non-Galex" targets have high proper motions. Thus, in the decades separating sky surveys like POSS and 2MASS from the present epoch, the proper motion of the typical EclipSS target would place it at a position that was "uncovered" in the earlier surveys, and thus allow any current close background object to be identified. Also, the ecliptic poles are away from the galactic equator, so the density of, say, background 14th magnitude O-type stars would be small to begin with, and the chances of a high-latitude hot star accidentally falling into the COS aperture is vanishingly small. (The one possible exception is HD39194 [target #41], which happens to be projected against the outskirts of the LMC. Fortunately, this is one of the high proper motion stars, and the target confirmation chart shows that the contemporary position is free of any other objects.)

Proposal 15300 - Visit 01 - Ecliptic-poles Stellar Survey (EclipSS)

Thu Dec 13 22:02:06 GMT 2018

Visit	Proposal 15300, Visit 01, completed Diagnostic Status: Warning Scientific Instruments: COS/FUV, COS/NUV Special Requirements: (none)																																																																																																									
	(Visit 01) Warning (Form): For the best data quality, it is strongly recommended that the maximum number of allowed FP-POS positions is used when observing at a given COS CENWAVE setting. See full description for details. (Visit 01) Warning (Orbit Planner): ORBITAL VISIBILITY OVERRUN																																																																																																									
Diagnosics																																																																																																										
Fixed Targets	<table border="1"> <thead> <tr> <th>#</th> <th>Name</th> <th>Target Coordinates</th> <th>Targ. Coord. Corrections</th> <th>Fluxes</th> <th>Miscellaneous</th> </tr> </thead> <tbody> <tr> <td>(1)</td> <td>HD156559</td> <td>RA: 17 14 43.8160 (258.6825667d) Dec: +58 23 2.63 (58.38406d) Equinox: J2000</td> <td>Proper Motion RA: -3.39 mas/yr Proper Motion Dec: 41.06 mas/yr Parallax: 0.01258" Epoch of Position: 2000 Radial Velocity: 0.0 km/sec</td> <td>V=7.89+/-0.1 sptyp= F2V; (B-V)= 0.37 mag; dist= 84 pc</td> <td>Reference Frame: ICRS</td> </tr> </tbody> </table>	#	Name	Target Coordinates	Targ. Coord. Corrections	Fluxes	Miscellaneous	(1)	HD156559	RA: 17 14 43.8160 (258.6825667d) Dec: +58 23 2.63 (58.38406d) Equinox: J2000	Proper Motion RA: -3.39 mas/yr Proper Motion Dec: 41.06 mas/yr Parallax: 0.01258" Epoch of Position: 2000 Radial Velocity: 0.0 km/sec	V=7.89+/-0.1 sptyp= F2V; (B-V)= 0.37 mag; dist= 84 pc	Reference Frame: ICRS	Comments: Category=STAR Description=[F0-F2] Extended=NO																																																																																												
	#	Name	Target Coordinates	Targ. Coord. Corrections	Fluxes	Miscellaneous																																																																																																				
(1)	HD156559	RA: 17 14 43.8160 (258.6825667d) Dec: +58 23 2.63 (58.38406d) Equinox: J2000	Proper Motion RA: -3.39 mas/yr Proper Motion Dec: 41.06 mas/yr Parallax: 0.01258" Epoch of Position: 2000 Radial Velocity: 0.0 km/sec	V=7.89+/-0.1 sptyp= F2V; (B-V)= 0.37 mag; dist= 84 pc	Reference Frame: ICRS																																																																																																					
Exposures	<table border="1"> <thead> <tr> <th>#</th> <th>Label (ETC Run)</th> <th>Target</th> <th>Config,Mode,Aperture</th> <th>Spectral Els.</th> <th>Opt. Params.</th> <th>Special Reqs.</th> <th>Groups</th> <th>Exp. Time (Total)/[Actual Dur.]</th> <th>Orbit</th> </tr> </thead> <tbody> <tr> <td>1</td> <td>(COS.ta.100 4259)</td> <td>(1) HD156559</td> <td>COS/NUV, ACQ/IMAGE, BOA</td> <td>MIRRORB</td> <td></td> <td></td> <td></td> <td>30 Secs (30 Secs) [==>]</td> <td>[1]</td> </tr> <tr> <td>2</td> <td>(COS.sp.100 5139)</td> <td>(1) HD156559</td> <td>COS/FUV, TIME-TAG, PSA</td> <td>G130M 1222 A</td> <td>BUFFER-TIME=47 2; FP-POS=3</td> <td></td> <td></td> <td>572 Secs (572 Secs) [==>]</td> <td>[1]</td> </tr> <tr> <td colspan="10"> Comments: Note: ETC simulation (for G130M-1291, so as to include Ly-alpha) is for an "extreme" FUV spectrum, scaled to V=7.2 mag, and thus will over-predict count rates for most of the targets (see Observation Description). </td> </tr> <tr> <td>3</td> <td>(COS.sp.100 5139)</td> <td>(1) HD156559</td> <td>COS/FUV, TIME-TAG, PSA</td> <td>G130M 1222 A</td> <td>BUFFER-TIME=47 2; FP-POS=4</td> <td></td> <td></td> <td>572 Secs (572 Secs) [==>]</td> <td>[1]</td> </tr> <tr> <td colspan="10"> Comments: Note: ETC simulation (for G130M-1291, so as to include Ly-alpha) is for an "extreme" FUV spectrum, scaled to V=7.2 mag, and thus will over-predict count rates for most of the targets (see Observation Description). </td> </tr> <tr> <td>4</td> <td>(COS.sp.100 5139)</td> <td>(1) HD156559</td> <td>COS/FUV, TIME-TAG, PSA</td> <td>G130M 1291 A</td> <td>BUFFER-TIME=47 2; FP-POS=3</td> <td></td> <td></td> <td>572 Secs (572 Secs) [==>]</td> <td>[1]</td> </tr> <tr> <td colspan="10"> Comments: Note: ETC simulation (for G130M-1291, so as to include Ly-alpha) is for an "extreme" FUV spectrum, scaled to V=7.2 mag, and thus will over-predict count rates for most of the targets (see Observation Description). </td> </tr> <tr> <td>5</td> <td>(COS.sp.100 5139)</td> <td>(1) HD156559</td> <td>COS/FUV, TIME-TAG, PSA</td> <td>G130M 1291 A</td> <td>BUFFER-TIME=47 2; FP-POS=4</td> <td></td> <td></td> <td>572 Secs (572 Secs) [==>]</td> <td>[1]</td> </tr> <tr> <td colspan="10"> Comments: Note: ETC simulation (for G130M-1291, so as to include Ly-alpha) is for an "extreme" FUV spectrum, scaled to V=7.2 mag, and thus will over-predict count rates for most of the targets (see Observation Description). </td> </tr> </tbody> </table>	#	Label (ETC Run)	Target	Config,Mode,Aperture	Spectral Els.	Opt. Params.	Special Reqs.	Groups	Exp. Time (Total)/[Actual Dur.]	Orbit	1	(COS.ta.100 4259)	(1) HD156559	COS/NUV, ACQ/IMAGE, BOA	MIRRORB				30 Secs (30 Secs) [==>]	[1]	2	(COS.sp.100 5139)	(1) HD156559	COS/FUV, TIME-TAG, PSA	G130M 1222 A	BUFFER-TIME=47 2; FP-POS=3			572 Secs (572 Secs) [==>]	[1]	Comments: Note: ETC simulation (for G130M-1291, so as to include Ly-alpha) is for an "extreme" FUV spectrum, scaled to V=7.2 mag, and thus will over-predict count rates for most of the targets (see Observation Description).										3	(COS.sp.100 5139)	(1) HD156559	COS/FUV, TIME-TAG, PSA	G130M 1222 A	BUFFER-TIME=47 2; FP-POS=4			572 Secs (572 Secs) [==>]	[1]	Comments: Note: ETC simulation (for G130M-1291, so as to include Ly-alpha) is for an "extreme" FUV spectrum, scaled to V=7.2 mag, and thus will over-predict count rates for most of the targets (see Observation Description).										4	(COS.sp.100 5139)	(1) HD156559	COS/FUV, TIME-TAG, PSA	G130M 1291 A	BUFFER-TIME=47 2; FP-POS=3			572 Secs (572 Secs) [==>]	[1]	Comments: Note: ETC simulation (for G130M-1291, so as to include Ly-alpha) is for an "extreme" FUV spectrum, scaled to V=7.2 mag, and thus will over-predict count rates for most of the targets (see Observation Description).										5	(COS.sp.100 5139)	(1) HD156559	COS/FUV, TIME-TAG, PSA	G130M 1291 A	BUFFER-TIME=47 2; FP-POS=4			572 Secs (572 Secs) [==>]	[1]	Comments: Note: ETC simulation (for G130M-1291, so as to include Ly-alpha) is for an "extreme" FUV spectrum, scaled to V=7.2 mag, and thus will over-predict count rates for most of the targets (see Observation Description).														
	#	Label (ETC Run)	Target	Config,Mode,Aperture	Spectral Els.	Opt. Params.	Special Reqs.	Groups	Exp. Time (Total)/[Actual Dur.]	Orbit																																																																																																
	1	(COS.ta.100 4259)	(1) HD156559	COS/NUV, ACQ/IMAGE, BOA	MIRRORB				30 Secs (30 Secs) [==>]	[1]																																																																																																
	2	(COS.sp.100 5139)	(1) HD156559	COS/FUV, TIME-TAG, PSA	G130M 1222 A	BUFFER-TIME=47 2; FP-POS=3			572 Secs (572 Secs) [==>]	[1]																																																																																																
	Comments: Note: ETC simulation (for G130M-1291, so as to include Ly-alpha) is for an "extreme" FUV spectrum, scaled to V=7.2 mag, and thus will over-predict count rates for most of the targets (see Observation Description).																																																																																																									
	3	(COS.sp.100 5139)	(1) HD156559	COS/FUV, TIME-TAG, PSA	G130M 1222 A	BUFFER-TIME=47 2; FP-POS=4			572 Secs (572 Secs) [==>]	[1]																																																																																																
Comments: Note: ETC simulation (for G130M-1291, so as to include Ly-alpha) is for an "extreme" FUV spectrum, scaled to V=7.2 mag, and thus will over-predict count rates for most of the targets (see Observation Description).																																																																																																										
4	(COS.sp.100 5139)	(1) HD156559	COS/FUV, TIME-TAG, PSA	G130M 1291 A	BUFFER-TIME=47 2; FP-POS=3			572 Secs (572 Secs) [==>]	[1]																																																																																																	
Comments: Note: ETC simulation (for G130M-1291, so as to include Ly-alpha) is for an "extreme" FUV spectrum, scaled to V=7.2 mag, and thus will over-predict count rates for most of the targets (see Observation Description).																																																																																																										
5	(COS.sp.100 5139)	(1) HD156559	COS/FUV, TIME-TAG, PSA	G130M 1291 A	BUFFER-TIME=47 2; FP-POS=4			572 Secs (572 Secs) [==>]	[1]																																																																																																	
Comments: Note: ETC simulation (for G130M-1291, so as to include Ly-alpha) is for an "extreme" FUV spectrum, scaled to V=7.2 mag, and thus will over-predict count rates for most of the targets (see Observation Description).																																																																																																										

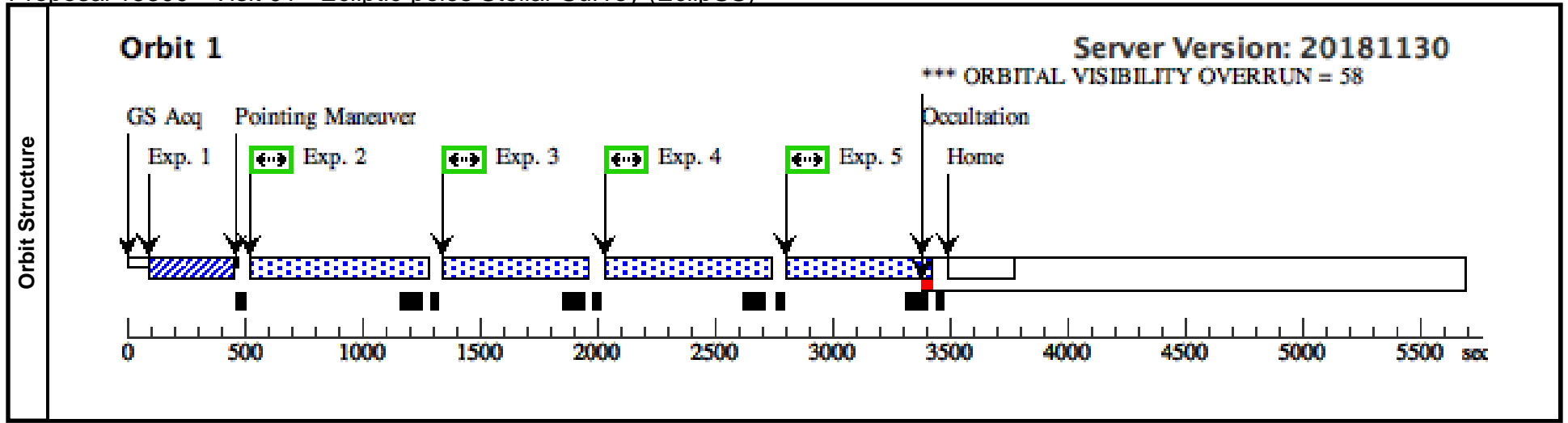

Proposal 15300 - Visit 02 - Ecliptic-poles Stellar Survey (EclipSS)

Thu Dec 13 22:02:07 GMT 2018

Visit	Proposal 15300, Visit 02, completed Diagnostic Status: Warning Scientific Instruments: COS/FUV, COS/NUV Special Requirements: (none)										
	(Visit 02) Warning (Form): For the best data quality, it is strongly recommended that the maximum number of allowed FP-POS positions is used when observing at a given COS CENWAVE setting. See full description for details. (Visit 02) Warning (Orbit Planner): ORBITAL VISIBILITY OVERRUN										
Fixed Targets	#	Name	Target Coordinates	Targ. Coord. Corrections	Fluxes	Miscellaneous					
	(2)	HD39755	RA: 05 50 18.6788 (87.5778283d) Dec: -62 04 48.72 (-62.08020d) Equinox: J2000	Proper Motion RA: -34.40 mas/yr Proper Motion Dec: -34.00 mas/yr Parallax: 0.01136" Epoch of Position: 2000 Radial Velocity: 0.0 km/sec	V=7.82+/-0.1 sptyp= F2V; (B-V)= 0.38 mag; dist= 79 pc	Reference Frame: ICRS					
Comments: Category=STAR Description=[F0-F2] Extended=NO											
Exposures	#	Label (ETC Run)	Target	Config,Mode,Aperture	Spectral Els.	Opt. Params.	Special Reqs.	Groups	Exp. Time (Total)/[Actual Dur.]	Orbit	
	1	(COS.ta.100 4260)	(2) HD39755	COS/NUV, ACQ/IMAGE, BOA	MIRRORB				27 Secs (27 Secs) [==>]	[1]	
	2	(COS.sp.100 5139)	(2) HD39755	COS/FUV, TIME-TAG, PSA	G130M 1222 A	BUFFER-TIME=47 9; FP-POS=3			579 Secs (579 Secs) [==>]	[1]	
	Comments: Note: ETC simulation (for G130M-1291, so as to include Ly-alpha) is for an "extreme" FUV spectrum, scaled to V=7.2 mag, and thus will over-predict count rates for most of the targets (see Observation Description).										
	3	(COS.sp.100 5139)	(2) HD39755	COS/FUV, TIME-TAG, PSA	G130M 1222 A	BUFFER-TIME=47 9; FP-POS=4			579 Secs (579 Secs) [==>]	[1]	
	Comments: Note: ETC simulation (for G130M-1291, so as to include Ly-alpha) is for an "extreme" FUV spectrum, scaled to V=7.2 mag, and thus will over-predict count rates for most of the targets (see Observation Description).										
4	(COS.sp.100 5139)	(2) HD39755	COS/FUV, TIME-TAG, PSA	G130M 1291 A	BUFFER-TIME=47 9; FP-POS=3			579 Secs (579 Secs) [==>]	[1]		
Comments: Note: ETC simulation (for G130M-1291, so as to include Ly-alpha) is for an "extreme" FUV spectrum, scaled to V=7.2 mag, and thus will over-predict count rates for most of the targets (see Observation Description).											
5	(COS.sp.100 5139)	(2) HD39755	COS/FUV, TIME-TAG, PSA	G130M 1291 A	BUFFER-TIME=47 9; FP-POS=4			579 Secs (579 Secs) [==>]	[1]		
Comments: Note: ETC simulation (for G130M-1291, so as to include Ly-alpha) is for an "extreme" FUV spectrum, scaled to V=7.2 mag, and thus will over-predict count rates for most of the targets (see Observation Description).											

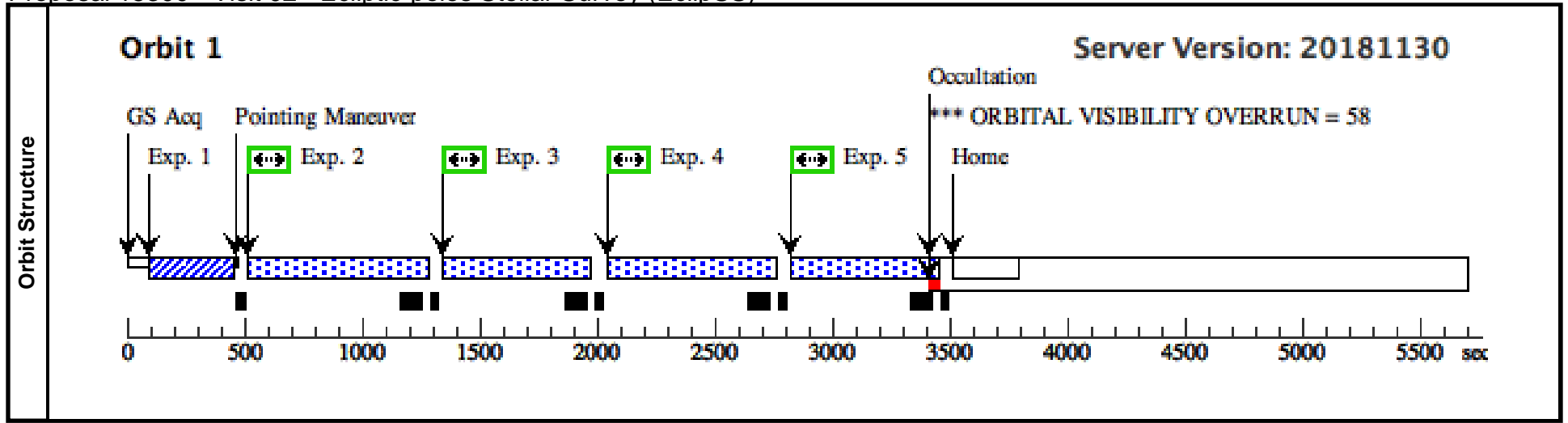

Proposal 15300 - Visit 03 - Ecliptic-poles Stellar Survey (EclipSS)

Thu Dec 13 22:02:07 GMT 2018

Visit	Proposal 15300, Visit 03, completed Diagnostic Status: Warning Scientific Instruments: COS/FUV, COS/NUV Special Requirements: ORIENT 64D TO 124 D; ORIENT 244D TO 304 D <i>Comments: AB 0.4" PA=319 dHp=0.28; ORIENT to separate nearly equal pair spatially</i>									
	(Visit 03) Warning (Form): For the best data quality, it is strongly recommended that the maximum number of allowed FP-POS positions is used when observing at a given COS CENWAVE setting. See full description for details. (Visit 03) Warning (Orbit Planner): ORBITAL VISIBILITY OVERRUN									
Diagnosics										
Fixed Targets	#	Name	Target Coordinates	Targ. Coord. Corrections	Fluxes	Miscellaneous				
	(3)	HD156389	RA: 17 14 6.8300 (258.5284583d) Dec: +56 08 1.64 (56.13379d) Equinox: J2000	Proper Motion RA: -17.66 mas/yr Proper Motion Dec: 10.37 mas/yr Parallax: 0.01158" Epoch of Position: 2000 Radial Velocity: 0.0 km/sec	V=7.77+/-0.1 sptyp= F2V; (B-V)= 0.45 mag; dist= 86 pc	Reference Frame: ICRS				
<i>Comments: Category=STAR Description=[F0-F2] Extended=NO</i>										
Exposures	#	Label (ETC Run)	Target	Config,Mode,Aperture	Spectral Els.	Opt. Params.	Special Reqs.	Groups	Exp. Time (Total)/[Actual Dur.]	Orbit
	1	(COS.ta.100 4261)	(3) HD156389	COS/NUV, ACQ/IMAGE, BOA	MIRRORB				26 Secs (26 Secs) [==>]	[1]
2	(COS.sp.100 5139)	(3) HD156389	COS/FUV, TIME-TAG, PSA	G130M 1222 A	BUFFER-TIME=47 4; FP-POS=3			574 Secs (574 Secs) [==>]	[1]	
<i>Comments: Note: ETC simulation (for G130M-1291, so as to include Ly-alpha) is for an "extreme" FUV spectrum, scaled to V=7.2 mag, and thus will over-predict count rates for most of the targets (see Observation Description).</i>										
3	(COS.sp.100 5139)	(3) HD156389	COS/FUV, TIME-TAG, PSA	G130M 1222 A	BUFFER-TIME=47 4; FP-POS=4			574 Secs (574 Secs) [==>]	[1]	
4	(COS.sp.100 5139)	(3) HD156389	COS/FUV, TIME-TAG, PSA	G130M 1291 A	BUFFER-TIME=47 4; FP-POS=3			574 Secs (574 Secs) [==>]	[1]	
<i>Comments: Note: ETC simulation (for G130M-1291, so as to include Ly-alpha) is for an "extreme" FUV spectrum, scaled to V=7.2 mag, and thus will over-predict count rates for most of the targets (see Observation Description).</i>										
5	(COS.sp.100 5139)	(3) HD156389	COS/FUV, TIME-TAG, PSA	G130M 1291 A	BUFFER-TIME=47 4; FP-POS=4			574 Secs (574 Secs) [==>]	[1]	
<i>Comments: Note: ETC simulation (for G130M-1291, so as to include Ly-alpha) is for an "extreme" FUV spectrum, scaled to V=7.2 mag, and thus will over-predict count rates for most of the targets (see Observation Description).</i>										

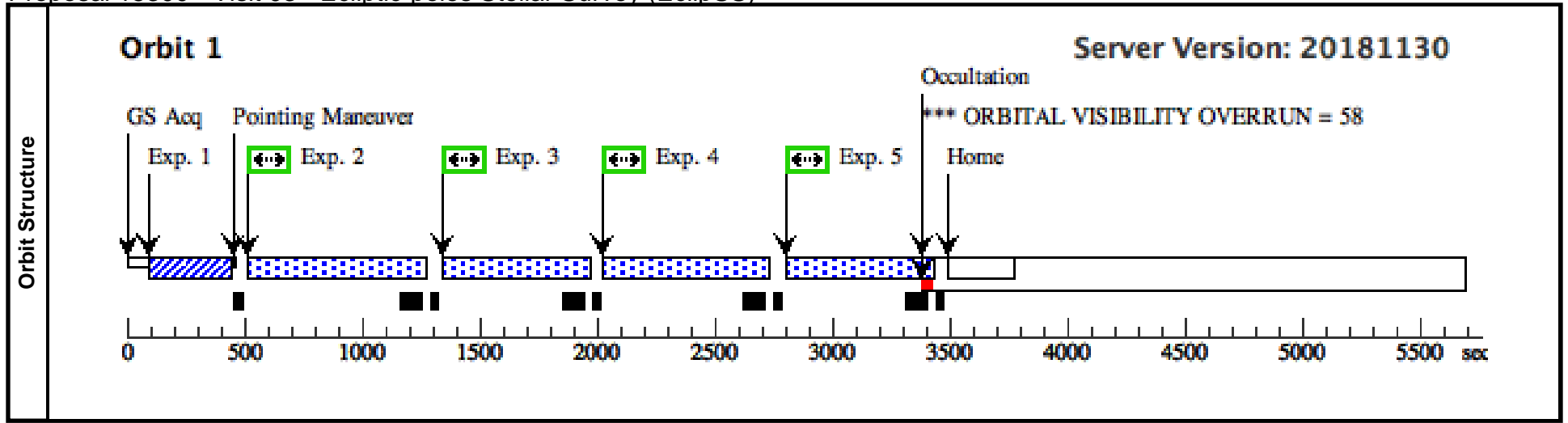

Proposal 15300 - Visit 04 - Ecliptic-poles Stellar Survey (EclipSS)

Thu Dec 13 22:02:07 GMT 2018

Visit	Proposal 15300, Visit 04, completed Diagnostic Status: Warning Scientific Instruments: COS/FUV, COS/NUV Special Requirements: (none)																																																																																																								
	(Visit 04) Warning (Form): For the best data quality, it is strongly recommended that the maximum number of allowed FP-POS positions is used when observing at a given COS CENWAVE setting. See full description for details. (Visit 04) Warning (Orbit Planner): ORBITAL VISIBILITY OVERRUN																																																																																																								
Diagnosics																																																																																																									
Fixed Targets	<table border="1"> <thead> <tr> <th>#</th> <th>Name</th> <th>Target Coordinates</th> <th>Targ. Coord. Corrections</th> <th>Fluxes</th> <th>Miscellaneous</th> </tr> </thead> <tbody> <tr> <td>(4)</td> <td>HD24636</td> <td>RA: 03 48 11.4714 (57.0477975d) Dec: -74 41 38.82 (-74.69412d) Equinox: J2000</td> <td>Proper Motion RA: 63.46 mas/yr Proper Motion Dec: 24.86 mas/yr Parallax: 0.01850" Epoch of Position: 2000 Radial Velocity: 0. km/sec</td> <td>V=7.12+/-0.1 sptyp= F3V; (B-V)= 0.38 mag; dist= 57 pc</td> <td>Reference Frame: ICRS</td> </tr> </tbody> </table>	#	Name	Target Coordinates	Targ. Coord. Corrections	Fluxes	Miscellaneous	(4)	HD24636	RA: 03 48 11.4714 (57.0477975d) Dec: -74 41 38.82 (-74.69412d) Equinox: J2000	Proper Motion RA: 63.46 mas/yr Proper Motion Dec: 24.86 mas/yr Parallax: 0.01850" Epoch of Position: 2000 Radial Velocity: 0. km/sec	V=7.12+/-0.1 sptyp= F3V; (B-V)= 0.38 mag; dist= 57 pc	Reference Frame: ICRS	Comments: Category=STAR Description=[F3-F9] Extended=NO																																																																																											
	#	Name	Target Coordinates	Targ. Coord. Corrections	Fluxes	Miscellaneous																																																																																																			
(4)	HD24636	RA: 03 48 11.4714 (57.0477975d) Dec: -74 41 38.82 (-74.69412d) Equinox: J2000	Proper Motion RA: 63.46 mas/yr Proper Motion Dec: 24.86 mas/yr Parallax: 0.01850" Epoch of Position: 2000 Radial Velocity: 0. km/sec	V=7.12+/-0.1 sptyp= F3V; (B-V)= 0.38 mag; dist= 57 pc	Reference Frame: ICRS																																																																																																				
<table border="1"> <thead> <tr> <th>#</th> <th>Label (ETC Run)</th> <th>Target</th> <th>Config,Mode,Aperture</th> <th>Spectral Els.</th> <th>Opt. Params.</th> <th>Special Reqs.</th> <th>Groups</th> <th>Exp. Time (Total)/[Actual Dur.]</th> <th>Orbit</th> </tr> </thead> <tbody> <tr> <td>1</td> <td>(COS.ta.100 4262)</td> <td>(4) HD24636</td> <td>COS/NUV, ACQ/IMAGE, BOA</td> <td>MIRRORB</td> <td></td> <td></td> <td></td> <td>16 Secs (16 Secs) [==>]</td> <td>[1]</td> </tr> <tr> <td>2</td> <td>(COS.sp.100 5139)</td> <td>(4) HD24636</td> <td>COS/FUV, TIME-TAG, PSA</td> <td>G130M 1222 A</td> <td>BUFFER-TIME=51 3; FP-POS=3</td> <td></td> <td></td> <td>613 Secs (613 Secs) [==>]</td> <td>[1]</td> </tr> <tr> <td colspan="10"> Comments: Note: ETC simulation (for G130M-1291, so as to include Ly-alpha) is for an "extreme" FUV spectrum, scaled to V=7.2 mag, and thus will over-predict count rates for most of the targets (see Observation Description). </td> </tr> <tr> <td>3</td> <td>(COS.sp.100 5139)</td> <td>(4) HD24636</td> <td>COS/FUV, TIME-TAG, PSA</td> <td>G130M 1222 A</td> <td>BUFFER-TIME=51 3; FP-POS=4</td> <td></td> <td></td> <td>613 Secs (613 Secs) [==>]</td> <td>[1]</td> </tr> <tr> <td colspan="10"> Comments: Note: ETC simulation (for G130M-1291, so as to include Ly-alpha) is for an "extreme" FUV spectrum, scaled to V=7.2 mag, and thus will over-predict count rates for most of the targets (see Observation Description). </td> </tr> <tr> <td>4</td> <td>(COS.sp.100 5139)</td> <td>(4) HD24636</td> <td>COS/FUV, TIME-TAG, PSA</td> <td>G130M 1291 A</td> <td>BUFFER-TIME=51 3; FP-POS=3</td> <td></td> <td></td> <td>613 Secs (613 Secs) [==>]</td> <td>[1]</td> </tr> <tr> <td colspan="10"> Comments: Note: ETC simulation (for G130M-1291, so as to include Ly-alpha) is for an "extreme" FUV spectrum, scaled to V=7.2 mag, and thus will over-predict count rates for most of the targets (see Observation Description). </td> </tr> <tr> <td>5</td> <td>(COS.sp.100 5139)</td> <td>(4) HD24636</td> <td>COS/FUV, TIME-TAG, PSA</td> <td>G130M 1291 A</td> <td>BUFFER-TIME=51 3; FP-POS=4</td> <td></td> <td></td> <td>613 Secs (613 Secs) [==>]</td> <td>[1]</td> </tr> <tr> <td colspan="10"> Comments: Note: ETC simulation (for G130M-1291, so as to include Ly-alpha) is for an "extreme" FUV spectrum, scaled to V=7.2 mag, and thus will over-predict count rates for most of the targets (see Observation Description). </td> </tr> </tbody> </table>						#	Label (ETC Run)	Target	Config,Mode,Aperture	Spectral Els.	Opt. Params.	Special Reqs.	Groups	Exp. Time (Total)/[Actual Dur.]	Orbit	1	(COS.ta.100 4262)	(4) HD24636	COS/NUV, ACQ/IMAGE, BOA	MIRRORB				16 Secs (16 Secs) [==>]	[1]	2	(COS.sp.100 5139)	(4) HD24636	COS/FUV, TIME-TAG, PSA	G130M 1222 A	BUFFER-TIME=51 3; FP-POS=3			613 Secs (613 Secs) [==>]	[1]	Comments: Note: ETC simulation (for G130M-1291, so as to include Ly-alpha) is for an "extreme" FUV spectrum, scaled to V=7.2 mag, and thus will over-predict count rates for most of the targets (see Observation Description).										3	(COS.sp.100 5139)	(4) HD24636	COS/FUV, TIME-TAG, PSA	G130M 1222 A	BUFFER-TIME=51 3; FP-POS=4			613 Secs (613 Secs) [==>]	[1]	Comments: Note: ETC simulation (for G130M-1291, so as to include Ly-alpha) is for an "extreme" FUV spectrum, scaled to V=7.2 mag, and thus will over-predict count rates for most of the targets (see Observation Description).										4	(COS.sp.100 5139)	(4) HD24636	COS/FUV, TIME-TAG, PSA	G130M 1291 A	BUFFER-TIME=51 3; FP-POS=3			613 Secs (613 Secs) [==>]	[1]	Comments: Note: ETC simulation (for G130M-1291, so as to include Ly-alpha) is for an "extreme" FUV spectrum, scaled to V=7.2 mag, and thus will over-predict count rates for most of the targets (see Observation Description).										5	(COS.sp.100 5139)	(4) HD24636	COS/FUV, TIME-TAG, PSA	G130M 1291 A	BUFFER-TIME=51 3; FP-POS=4			613 Secs (613 Secs) [==>]	[1]	Comments: Note: ETC simulation (for G130M-1291, so as to include Ly-alpha) is for an "extreme" FUV spectrum, scaled to V=7.2 mag, and thus will over-predict count rates for most of the targets (see Observation Description).									
#	Label (ETC Run)	Target	Config,Mode,Aperture	Spectral Els.	Opt. Params.	Special Reqs.	Groups	Exp. Time (Total)/[Actual Dur.]	Orbit																																																																																																
1	(COS.ta.100 4262)	(4) HD24636	COS/NUV, ACQ/IMAGE, BOA	MIRRORB				16 Secs (16 Secs) [==>]	[1]																																																																																																
2	(COS.sp.100 5139)	(4) HD24636	COS/FUV, TIME-TAG, PSA	G130M 1222 A	BUFFER-TIME=51 3; FP-POS=3			613 Secs (613 Secs) [==>]	[1]																																																																																																
Comments: Note: ETC simulation (for G130M-1291, so as to include Ly-alpha) is for an "extreme" FUV spectrum, scaled to V=7.2 mag, and thus will over-predict count rates for most of the targets (see Observation Description).																																																																																																									
3	(COS.sp.100 5139)	(4) HD24636	COS/FUV, TIME-TAG, PSA	G130M 1222 A	BUFFER-TIME=51 3; FP-POS=4			613 Secs (613 Secs) [==>]	[1]																																																																																																
Comments: Note: ETC simulation (for G130M-1291, so as to include Ly-alpha) is for an "extreme" FUV spectrum, scaled to V=7.2 mag, and thus will over-predict count rates for most of the targets (see Observation Description).																																																																																																									
4	(COS.sp.100 5139)	(4) HD24636	COS/FUV, TIME-TAG, PSA	G130M 1291 A	BUFFER-TIME=51 3; FP-POS=3			613 Secs (613 Secs) [==>]	[1]																																																																																																
Comments: Note: ETC simulation (for G130M-1291, so as to include Ly-alpha) is for an "extreme" FUV spectrum, scaled to V=7.2 mag, and thus will over-predict count rates for most of the targets (see Observation Description).																																																																																																									
5	(COS.sp.100 5139)	(4) HD24636	COS/FUV, TIME-TAG, PSA	G130M 1291 A	BUFFER-TIME=51 3; FP-POS=4			613 Secs (613 Secs) [==>]	[1]																																																																																																
Comments: Note: ETC simulation (for G130M-1291, so as to include Ly-alpha) is for an "extreme" FUV spectrum, scaled to V=7.2 mag, and thus will over-predict count rates for most of the targets (see Observation Description).																																																																																																									
Exposures																																																																																																									

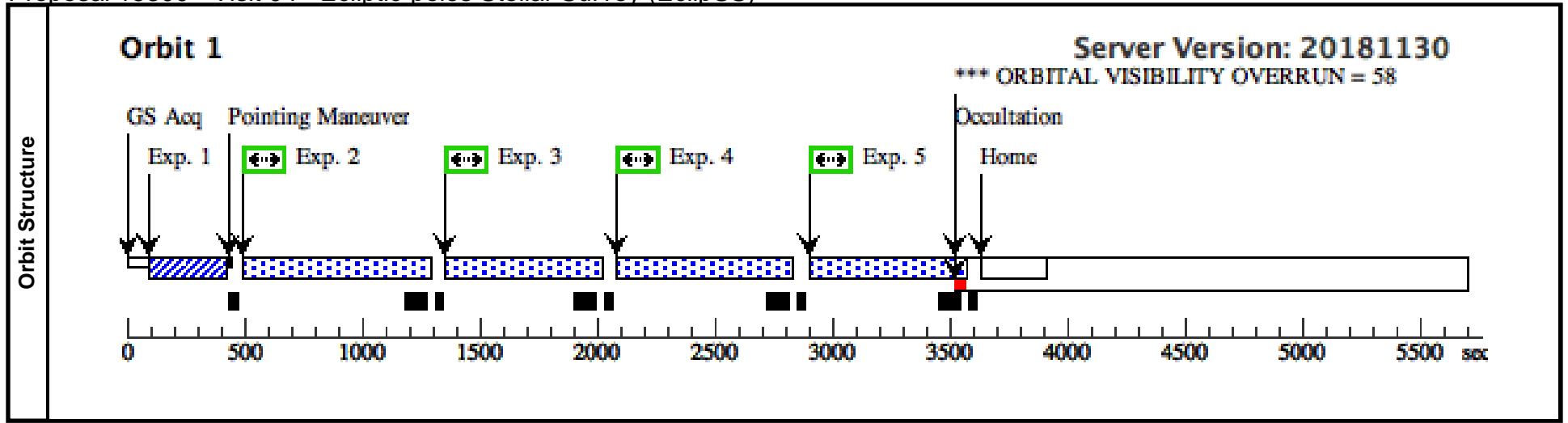

Proposal 15300 - Visit 05 - Ecliptic-poles Stellar Survey (EclipSS)

Thu Dec 13 22:02:07 GMT 2018

Visit	Proposal 15300, Visit 05, scheduled Diagnostic Status: Warning Scientific Instruments: COS/FUV, COS/NUV Special Requirements: (none)										
	(Visit 05) Warning (Form): For the best data quality, it is strongly recommended that the maximum number of allowed FP-POS positions is used when observing at a given COS CENWAVE setting. See full description for details. (Visit 05) Warning (Orbit Planner): ORBITAL VISIBILITY OVERRUN										
Diagnosics											
Fixed Targets	#	Name	Target Coordinates	Targ. Coord. Corrections		Fluxes	Miscellaneous				
	(5)	HD21166	RA: 03 18 57.7030 (49.7404292d) Dec: -73 59 10.47 (-73.98624d) Equinox: J2000	Proper Motion RA: -20.49 mas/yr Proper Motion Dec: -94.13 mas/yr Parallax: 0.01400" Epoch of Position: 2000 Radial Velocity: 0.0 km/sec	V=7.23+/-0.1 sptyp= F3V; (B-V)= 0.39 mag; dist= 73 pc		Reference Frame: ICRS				
Comments: Category=STAR Description=[F3-F9] Extended=NO											
Exposures	#	Label (ETC Run)	Target	Config,Mode,Aperture	Spectral Els.	Opt. Params.	Special Reqs.	Groups	Exp. Time (Total)/[Actual Dur.]		Orbit
	1	(COS.ta.100 4263)	(5) HD21166	COS/NUV, ACQ/IMAGE, BOA	MIRRORB				16 Secs (16 Secs) [==>]		[1]
2	(COS.sp.100 5139)	(5) HD21166	COS/FUV, TIME-TAG, PSA	G130M 1222 A	BUFFER-TIME=51 3; FP-POS=3			613 Secs (613 Secs) [==>]		[1]	
Comments: Note: ETC simulation (for G130M-1291, so as to include Ly-alpha) is for an "extreme" FUV spectrum, scaled to V=7.2 mag, and thus will over-predict count rates for most of the targets (see Observation Description).											
3	(COS.sp.100 5139)	(5) HD21166	COS/FUV, TIME-TAG, PSA	G130M 1222 A	BUFFER-TIME=51 3; FP-POS=4			613 Secs (613 Secs) [==>]		[1]	
Comments: Note: ETC simulation (for G130M-1291, so as to include Ly-alpha) is for an "extreme" FUV spectrum, scaled to V=7.2 mag, and thus will over-predict count rates for most of the targets (see Observation Description).											
4	(COS.sp.100 5139)	(5) HD21166	COS/FUV, TIME-TAG, PSA	G130M 1291 A	BUFFER-TIME=51 3; FP-POS=3			613 Secs (613 Secs) [==>]		[1]	
Comments: Note: ETC simulation (for G130M-1291, so as to include Ly-alpha) is for an "extreme" FUV spectrum, scaled to V=7.2 mag, and thus will over-predict count rates for most of the targets (see Observation Description).											
5	(COS.sp.100 5139)	(5) HD21166	COS/FUV, TIME-TAG, PSA	G130M 1291 A	BUFFER-TIME=51 3; FP-POS=4			613 Secs (613 Secs) [==>]		[1]	
Comments: Note: ETC simulation (for G130M-1291, so as to include Ly-alpha) is for an "extreme" FUV spectrum, scaled to V=7.2 mag, and thus will over-predict count rates for most of the targets (see Observation Description).											

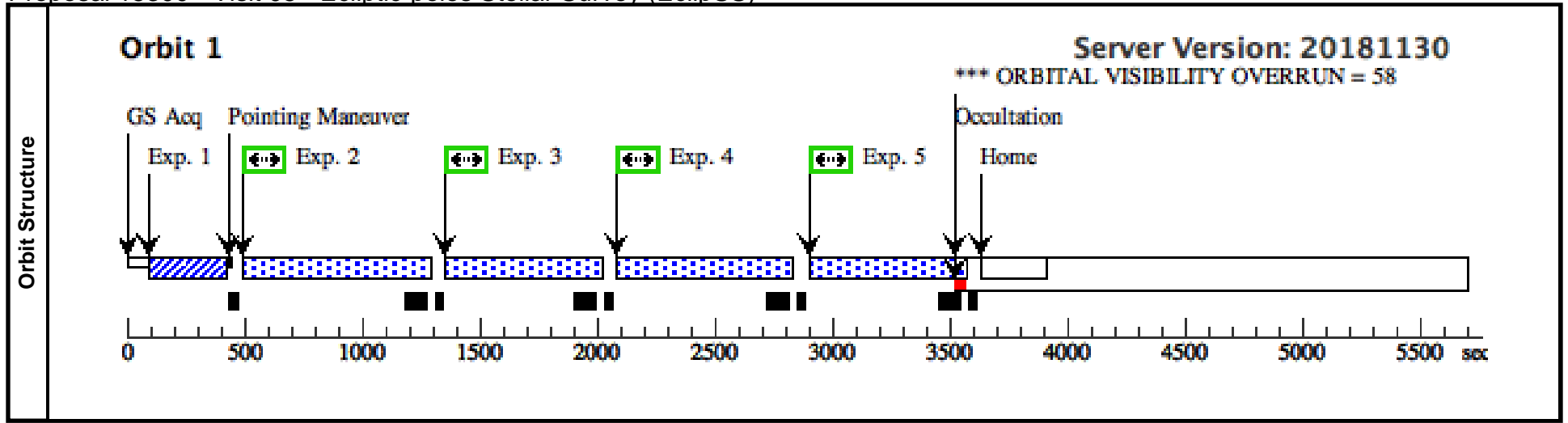

Proposal 15300 - Visit 06 - Ecliptic-poles Stellar Survey (EclipSS)

Thu Dec 13 22:02:07 GMT 2018

Visit	Proposal 15300, Visit 06, completed Diagnostic Status: Warning Scientific Instruments: COS/FUV, COS/NUV Special Requirements: (none)										
	(Visit 06) Warning (Form): For the best data quality, it is strongly recommended that the maximum number of allowed FP-POS positions is used when observing at a given COS CENWAVE setting. See full description for details. (Visit 06) Warning (Orbit Planner): ORBITAL VISIBILITY OVERRUN										
Fixed Targets	#	Name	Target Coordinates	Targ. Coord. Corrections	Fluxes	Miscellaneous					
	(6)	HD56737	RA: 07 14 22.5034 (108.5937642d) Dec: -61 04 11.24 (-61.06979d) Equinox: J2000	Proper Motion RA: -114.30 mas/yr Proper Motion Dec: 17.21 mas/yr Parallax: 0.01724" Epoch of Position: 2000 Radial Velocity: 0.0 km/sec	V=7.16+/-0.1 sptyp= F3V; (B-V)= 0.41 mag; dist= 59 pc	Reference Frame: ICRS					
Comments: Category=STAR Description=[F3-F9] Extended=NO											
Exposures	#	Label (ETC Run)	Target	Config,Mode,Aperture	Spectral Els.	Opt. Params.	Special Reqs.	Groups	Exp. Time (Total)/[Actual Dur.]	Orbit	
	1	(COS.ta.100 4264)	(6) HD56737	COS/NUV, ACQ/IMAGE, BOA	MIRRORB				17 Secs (17 Secs) [==>]	[1]	
	2	(COS.sp.100 5139)	(6) HD56737	COS/FUV, TIME-TAG, PSA	G130M 1222 A	BUFFER-TIME=48 4; FP-POS=3			584 Secs (584 Secs) [==>]	[1]	
	Comments: Note: ETC simulation (for G130M-1291, so as to include Ly-alpha) is for an "extreme" FUV spectrum, scaled to V=7.2 mag, and thus will over-predict count rates for most of the targets (see Observation Description).										
	3	(COS.sp.100 5139)	(6) HD56737	COS/FUV, TIME-TAG, PSA	G130M 1222 A	BUFFER-TIME=48 4; FP-POS=4			584 Secs (584 Secs) [==>]	[1]	
	Comments: Note: ETC simulation (for G130M-1291, so as to include Ly-alpha) is for an "extreme" FUV spectrum, scaled to V=7.2 mag, and thus will over-predict count rates for most of the targets (see Observation Description).										
4	(COS.sp.100 5139)	(6) HD56737	COS/FUV, TIME-TAG, PSA	G130M 1291 A	BUFFER-TIME=48 4; FP-POS=3			584 Secs (584 Secs) [==>]	[1]		
Comments: Note: ETC simulation (for G130M-1291, so as to include Ly-alpha) is for an "extreme" FUV spectrum, scaled to V=7.2 mag, and thus will over-predict count rates for most of the targets (see Observation Description).											
5	(COS.sp.100 5139)	(6) HD56737	COS/FUV, TIME-TAG, PSA	G130M 1291 A	BUFFER-TIME=48 4; FP-POS=4			584 Secs (584 Secs) [==>]	[1]		
Comments: Note: ETC simulation (for G130M-1291, so as to include Ly-alpha) is for an "extreme" FUV spectrum, scaled to V=7.2 mag, and thus will over-predict count rates for most of the targets (see Observation Description).											

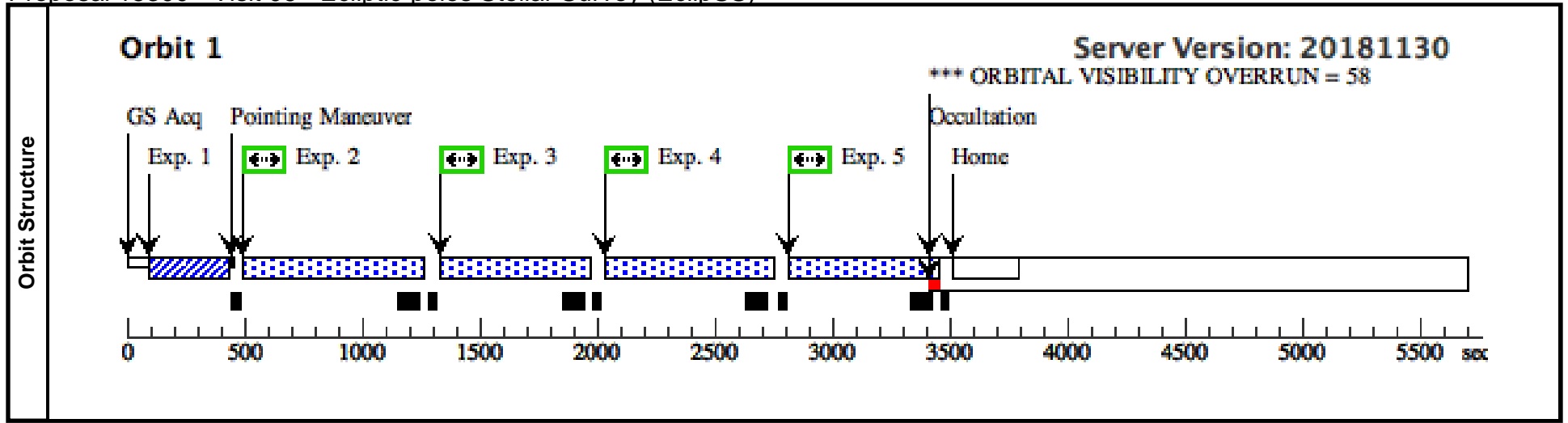

Proposal 15300 - Visit 07 - Ecliptic-poles Stellar Survey (EclipSS)

Thu Dec 13 22:02:07 GMT 2018

Visit	Proposal 15300, Visit 07, completed Diagnostic Status: Warning Scientific Instruments: COS/FUV, COS/NUV Special Requirements: (none)									
	(Visit 07) Warning (Form): For the best data quality, it is strongly recommended that the maximum number of allowed FP-POS positions is used when observing at a given COS CENWAVE setting. See full description for details. (Visit 07) Warning (Orbit Planner): ORBITAL VISIBILITY OVERRUN									
Diagnosics										
Fixed Targets	#	Name	Target Coordinates	Targ. Coord. Corrections	Fluxes	Miscellaneous				
	(7)	HD154956	RA: 17 05 47.5791 (256.4482462d) Dec: +53 45 3.42 (53.75095d) Equinox: J2000	Proper Motion RA: 36.03 mas/yr Proper Motion Dec: 90.32 mas/yr Parallax: 0.01036" Epoch of Position: 2000 Radial Velocity: 0.0 km/sec	V=8.29+/-0.1 sptyp= F5V; (B-V)= 0.46 mag; dist= 93 pc	Reference Frame: ICRS				
Comments: Category=STAR Description=[F3-F9] Extended=NO										
Exposures	#	Label (ETC Run)	Target	Config,Mode,Aperture	Spectral Els.	Opt. Params.	Special Reqs.	Groups	Exp. Time (Total)/[Actual Dur.]	Orbit
	1	(COS.ta.100 4266)	(7) HD154956	COS/NUV, ACQ/IMAGE, BOA	MIRRORA			GS ACQ SCENARI O BASE1B3	4 Secs (4 Secs) [==>]	[1]
2	(COS.sp.100 5139)	(7) HD154956	COS/FUV, TIME-TAG, PSA	G130M 1222 A	BUFFER-TIME=47 1; FP-POS=3			571 Secs (571 Secs) [==>]	[1]	
Comments: Note: ETC simulation (for G130M-1291, so as to include Ly-alpha) is for an "extreme" FUV spectrum, scaled to V=7.2 mag, and thus will over-predict count rates for most of the targets (see Observation Description).										
3	(COS.sp.100 5139)	(7) HD154956	COS/FUV, TIME-TAG, PSA	G130M 1222 A	BUFFER-TIME=47 1; FP-POS=4			571 Secs (571 Secs) [==>]	[1]	
Comments: Note: ETC simulation (for G130M-1291, so as to include Ly-alpha) is for an "extreme" FUV spectrum, scaled to V=7.2 mag, and thus will over-predict count rates for most of the targets (see Observation Description).										
4	(COS.sp.100 5139)	(7) HD154956	COS/FUV, TIME-TAG, PSA	G130M 1291 A	BUFFER-TIME=47 1; FP-POS=3			571 Secs (571 Secs) [==>]	[1]	
Comments: Note: ETC simulation (for G130M-1291, so as to include Ly-alpha) is for an "extreme" FUV spectrum, scaled to V=7.2 mag, and thus will over-predict count rates for most of the targets (see Observation Description).										
5	(COS.sp.100 5139)	(7) HD154956	COS/FUV, TIME-TAG, PSA	G130M 1291 A	BUFFER-TIME=47 1; FP-POS=4			571 Secs (571 Secs) [==>]	[1]	
Comments: Note: ETC simulation (for G130M-1291, so as to include Ly-alpha) is for an "extreme" FUV spectrum, scaled to V=7.2 mag, and thus will over-predict count rates for most of the targets (see Observation Description).										

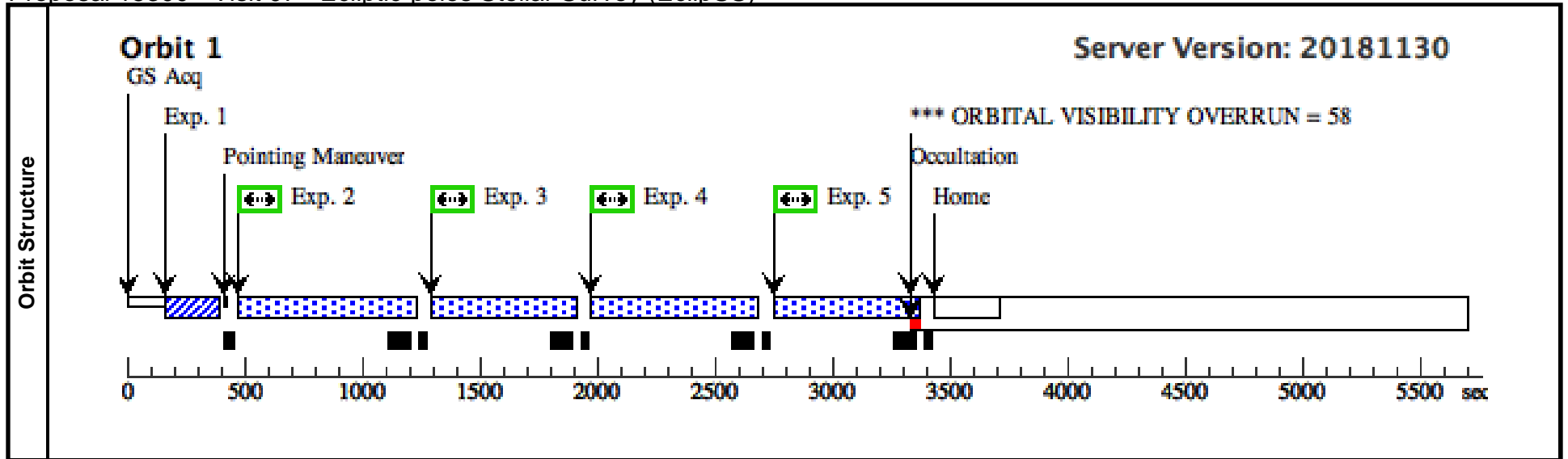

Proposal 15300 - Visit 08 - Ecliptic-poles Stellar Survey (EclipSS)

Thu Dec 13 22:02:07 GMT 2018

Visit	Proposal 15300, Visit 08, scheduled Diagnostic Status: Warning Scientific Instruments: COS/FUV, COS/NUV Special Requirements: (none)										
	(Visit 08) Warning (Form): For the best data quality, it is strongly recommended that the maximum number of allowed FP-POS positions is used when observing at a given COS CENWAVE setting. See full description for details. (Visit 08) Warning (Orbit Planner): ORBITAL VISIBILITY OVERRUN										
Fixed Targets	#	Name	Target Coordinates	Targ. Coord. Corrections	Fluxes	Miscellaneous					
	(8)	HD53658	RA: 07 01 5.4440 (105.2726833d) Dec: -65 42 23.40 (-65.70650d) Equinox: J2000	Proper Motion RA: -108.39 mas/yr Proper Motion Dec: 65.19 mas/yr Parallax: 0.01745" Epoch of Position: 2000 Radial Velocity: 0.0 km/sec	V=7.34+/-0.1 sptyp= F6V; (B-V)= 0.41 mag; dist= 57 pc	Reference Frame: ICRS					
Comments: Category=STAR Description=[F3-F9] Extended=NO											
Exposures	#	Label (ETC Run)	Target	Config,Mode,Aperture	Spectral Els.	Opt. Params.	Special Reqs.	Groups	Exp. Time (Total)/[Actual Dur.]	Orbit	
	1	(COS.ta.100 4269)	(8) HD53658	COS/NUV, ACQ/IMAGE, BOA	MIRRORB				28 Secs (28 Secs) [==>]	[1]	
	2	(COS.sp.100 5139)	(8) HD53658	COS/FUV, TIME-TAG, PSA	G130M 1222 A	BUFFER-TIME=49 7; FP-POS=3			597 Secs (597 Secs) [==>]	[1]	
	Comments: Note: ETC simulation (for G130M-1291, so as to include Ly-alpha) is for an "extreme" FUV spectrum, scaled to V=7.2 mag, and thus will over-predict count rates for most of the targets (see Observation Description).										
	3	(COS.sp.100 5139)	(8) HD53658	COS/FUV, TIME-TAG, PSA	G130M 1222 A	BUFFER-TIME=49 7; FP-POS=4			597 Secs (597 Secs) [==>]	[1]	
	Comments: Note: ETC simulation (for G130M-1291, so as to include Ly-alpha) is for an "extreme" FUV spectrum, scaled to V=7.2 mag, and thus will over-predict count rates for most of the targets (see Observation Description).										
4	(COS.sp.100 5139)	(8) HD53658	COS/FUV, TIME-TAG, PSA	G130M 1291 A	BUFFER-TIME=49 7; FP-POS=3			597 Secs (597 Secs) [==>]	[1]		
Comments: Note: ETC simulation (for G130M-1291, so as to include Ly-alpha) is for an "extreme" FUV spectrum, scaled to V=7.2 mag, and thus will over-predict count rates for most of the targets (see Observation Description).											
5	(COS.sp.100 5139)	(8) HD53658	COS/FUV, TIME-TAG, PSA	G130M 1291 A	BUFFER-TIME=49 7; FP-POS=4			597 Secs (597 Secs) [==>]	[1]		
Comments: Note: ETC simulation (for G130M-1291, so as to include Ly-alpha) is for an "extreme" FUV spectrum, scaled to V=7.2 mag, and thus will over-predict count rates for most of the targets (see Observation Description).											

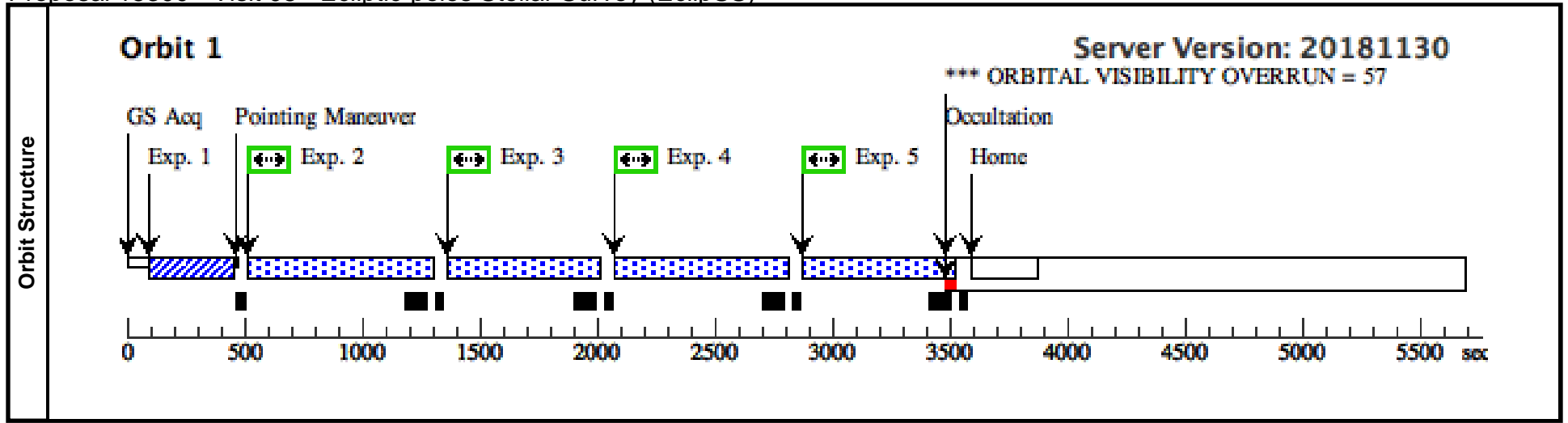

Proposal 15300 - Visit 09 - Ecliptic-poles Stellar Survey (EclipSS)

Thu Dec 13 22:02:07 GMT 2018

Visit	Proposal 15300, Visit 09, completed Diagnostic Status: Warning Scientific Instruments: COS/FUV, COS/NUV Special Requirements: (none)									
	(Visit 09) Warning (Form): For the best data quality, it is strongly recommended that the maximum number of allowed FP-POS positions is used when observing at a given COS CENWAVE setting. See full description for details. (Visit 09) Warning (Orbit Planner): ORBITAL VISIBILITY OVERRUN									
Diagnosics										
Fixed Targets	#	Name	Target Coordinates	Targ. Coord. Corrections	Fluxes	Miscellaneous				
	(9)	HD28481	RA: 04 26 38.9097 (66.6621238d) Dec: -53 42 15.23 (-53.70423d) Equinox: J2000	Proper Motion RA: -29.95 mas/yr Proper Motion Dec: 50.50 mas/yr Parallax: 0.01048" Epoch of Position: 2000 Radial Velocity: 0.0 km/sec	V=8.3+/-0.1 sptyp= F6V; (B-V)= 0.44 mag; dist= 100 pc	Reference Frame: ICRS				
Comments: Category=STAR Description=[F3-F9] Extended=NO										
Exposures	#	Label (ETC Run)	Target	Config,Mode,Aperture	Spectral Els.	Opt. Params.	Special Reqs.	Groups	Exp. Time (Total)/[Actual Dur.]	Orbit
	1	(COS.ta.100 4270)	(9) HD28481	COS/NUV, ACQ/IMAGE, BOA	MIRRORA				4 Secs (4 Secs) [==>]	[1]
2	(COS.sp.100 5139)	(9) HD28481	COS/FUV, TIME-TAG, PSA	G130M 1222 A	BUFFER-TIME=47 1; FP-POS=3			571 Secs (571 Secs) [==>]	[1]	
Comments: Note: ETC simulation (for G130M-1291, so as to include Ly-alpha) is for an "extreme" FUV spectrum, scaled to V=7.2 mag, and thus will over-predict count rates for most of the targets (see Observation Description).										
3	(COS.sp.100 5139)	(9) HD28481	COS/FUV, TIME-TAG, PSA	G130M 1222 A	BUFFER-TIME=47 1; FP-POS=4			571 Secs (571 Secs) [==>]	[1]	
Comments: Note: ETC simulation (for G130M-1291, so as to include Ly-alpha) is for an "extreme" FUV spectrum, scaled to V=7.2 mag, and thus will over-predict count rates for most of the targets (see Observation Description).										
4	(COS.sp.100 5139)	(9) HD28481	COS/FUV, TIME-TAG, PSA	G130M 1291 A	BUFFER-TIME=47 1; FP-POS=3			571 Secs (571 Secs) [==>]	[1]	
Comments: Note: ETC simulation (for G130M-1291, so as to include Ly-alpha) is for an "extreme" FUV spectrum, scaled to V=7.2 mag, and thus will over-predict count rates for most of the targets (see Observation Description).										
5	(COS.sp.100 5139)	(9) HD28481	COS/FUV, TIME-TAG, PSA	G130M 1291 A	BUFFER-TIME=47 1; FP-POS=4			571 Secs (571 Secs) [==>]	[1]	
Comments: Note: ETC simulation (for G130M-1291, so as to include Ly-alpha) is for an "extreme" FUV spectrum, scaled to V=7.2 mag, and thus will over-predict count rates for most of the targets (see Observation Description).										

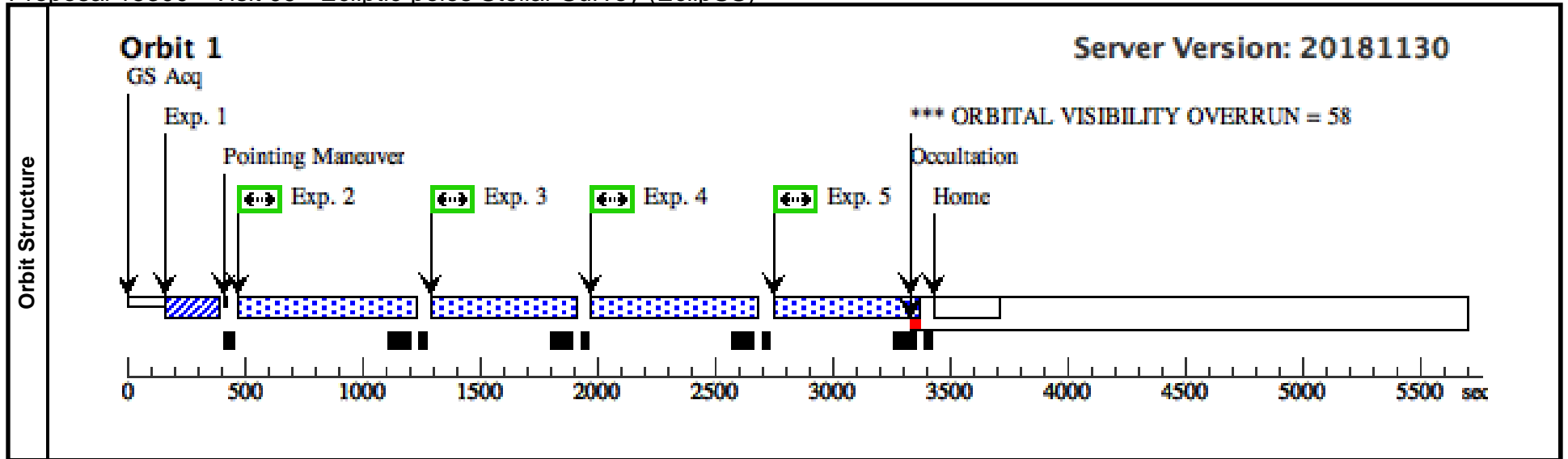

Proposal 15300 - Visit 10 - Ecliptic-poles Stellar Survey (EclipSS)

Thu Dec 13 22:02:07 GMT 2018

Visit	Proposal 15300, Visit 10, completed Diagnostic Status: Warning Scientific Instruments: COS/FUV, COS/NUV Special Requirements: ORIENT 190D TO 250 D; ORIENT 10D TO 70 D <i>Comments: AB 0.7" PA=85 dHp=0.35; ORIENT to separate nearly equal pair spatially</i>																																																																																																					
	(Visit 10) Warning (Form): For the best data quality, it is strongly recommended that the maximum number of allowed FP-POS positions is used when observing at a given COS CENWAVE setting. See full description for details. (Visit 10) Warning (Orbit Planner): ORBITAL VISIBILITY OVERRUN																																																																																																					
Diagnosics																																																																																																						
Fixed Targets	<table border="1"> <thead> <tr> <th>#</th> <th>Name</th> <th>Target Coordinates</th> <th>Targ. Coord. Corrections</th> <th>Fluxes</th> <th>Miscellaneous</th> </tr> </thead> <tbody> <tr> <td>(10)</td> <td>HD22359</td> <td>RA: 03 32 43.7745 (53.1823937d) Dec: -60 34 27.42 (-60.57428d) Equinox: J2000</td> <td>Proper Motion RA: 116.08 mas/yr Proper Motion Dec: 55.78 mas/yr Parallax: 0.01461" Epoch of Position: 2000 Radial Velocity: 0.0 km/sec</td> <td>V=7.65+/-0.1 sptyp= F6V; (B-V)= 0.46 mag; dist= 68 pc</td> <td>Reference Frame: ICRS</td> </tr> </tbody> </table>	#	Name	Target Coordinates	Targ. Coord. Corrections	Fluxes	Miscellaneous	(10)	HD22359	RA: 03 32 43.7745 (53.1823937d) Dec: -60 34 27.42 (-60.57428d) Equinox: J2000	Proper Motion RA: 116.08 mas/yr Proper Motion Dec: 55.78 mas/yr Parallax: 0.01461" Epoch of Position: 2000 Radial Velocity: 0.0 km/sec	V=7.65+/-0.1 sptyp= F6V; (B-V)= 0.46 mag; dist= 68 pc	Reference Frame: ICRS	<i>Comments:</i> Category=STAR Description=[F3-F9] Extended=NO																																																																																								
	#	Name	Target Coordinates	Targ. Coord. Corrections	Fluxes	Miscellaneous																																																																																																
(10)	HD22359	RA: 03 32 43.7745 (53.1823937d) Dec: -60 34 27.42 (-60.57428d) Equinox: J2000	Proper Motion RA: 116.08 mas/yr Proper Motion Dec: 55.78 mas/yr Parallax: 0.01461" Epoch of Position: 2000 Radial Velocity: 0.0 km/sec	V=7.65+/-0.1 sptyp= F6V; (B-V)= 0.46 mag; dist= 68 pc	Reference Frame: ICRS																																																																																																	
Exposures	<table border="1"> <thead> <tr> <th>#</th> <th>Label (ETC Run)</th> <th>Target</th> <th>Config,Mode,Aperture</th> <th>Spectral Els.</th> <th>Opt. Params.</th> <th>Special Reqs.</th> <th>Groups</th> <th>Exp. Time (Total)/[Actual Dur.]</th> <th>Orbit</th> </tr> </thead> <tbody> <tr> <td>1</td> <td>(COS.ta.100 4272)</td> <td>(10) HD22359</td> <td>COS/NUV, ACQ/IMAGE, BOA</td> <td>MIRRORB</td> <td></td> <td></td> <td></td> <td>37 Secs (37 Secs) [==>]</td> <td>[1]</td> </tr> <tr> <td>2</td> <td>(COS.sp.100 5139)</td> <td>(10) HD22359</td> <td>COS/FUV, TIME-TAG, PSA</td> <td>G130M 1222 A</td> <td>BUFFER-TIME=47 4; FP-POS=3</td> <td></td> <td></td> <td>574 Secs (574 Secs) [==>]</td> <td>[1]</td> </tr> <tr> <td colspan="9"> <i>Comments: Note: ETC simulation (for G130M-1291, so as to include Ly-alpha) is for an "extreme" FUV spectrum, scaled to V=7.2 mag, and thus will over-predict count rates for most of the targets (see Observation Description).</i> </td> </tr> <tr> <td>3</td> <td>(COS.sp.100 5139)</td> <td>(10) HD22359</td> <td>COS/FUV, TIME-TAG, PSA</td> <td>G130M 1222 A</td> <td>BUFFER-TIME=47 4; FP-POS=4</td> <td></td> <td></td> <td>574 Secs (574 Secs) [==>]</td> <td>[1]</td> </tr> <tr> <td colspan="9"> <i>Comments: Note: ETC simulation (for G130M-1291, so as to include Ly-alpha) is for an "extreme" FUV spectrum, scaled to V=7.2 mag, and thus will over-predict count rates for most of the targets (see Observation Description).</i> </td> </tr> <tr> <td>4</td> <td>(COS.sp.100 5139)</td> <td>(10) HD22359</td> <td>COS/FUV, TIME-TAG, PSA</td> <td>G130M 1291 A</td> <td>BUFFER-TIME=47 4; FP-POS=3</td> <td></td> <td></td> <td>574 Secs (574 Secs) [==>]</td> <td>[1]</td> </tr> <tr> <td colspan="9"> <i>Comments: Note: ETC simulation (for G130M-1291, so as to include Ly-alpha) is for an "extreme" FUV spectrum, scaled to V=7.2 mag, and thus will over-predict count rates for most of the targets (see Observation Description).</i> </td> </tr> <tr> <td>5</td> <td>(COS.sp.100 5139)</td> <td>(10) HD22359</td> <td>COS/FUV, TIME-TAG, PSA</td> <td>G130M 1291 A</td> <td>BUFFER-TIME=47 4; FP-POS=4</td> <td></td> <td></td> <td>574 Secs (574 Secs) [==>]</td> <td>[1]</td> </tr> <tr> <td colspan="9"> <i>Comments: Note: ETC simulation (for G130M-1291, so as to include Ly-alpha) is for an "extreme" FUV spectrum, scaled to V=7.2 mag, and thus will over-predict count rates for most of the targets (see Observation Description).</i> </td> </tr> </tbody> </table>	#	Label (ETC Run)	Target	Config,Mode,Aperture	Spectral Els.	Opt. Params.	Special Reqs.	Groups	Exp. Time (Total)/[Actual Dur.]	Orbit	1	(COS.ta.100 4272)	(10) HD22359	COS/NUV, ACQ/IMAGE, BOA	MIRRORB				37 Secs (37 Secs) [==>]	[1]	2	(COS.sp.100 5139)	(10) HD22359	COS/FUV, TIME-TAG, PSA	G130M 1222 A	BUFFER-TIME=47 4; FP-POS=3			574 Secs (574 Secs) [==>]	[1]	<i>Comments: Note: ETC simulation (for G130M-1291, so as to include Ly-alpha) is for an "extreme" FUV spectrum, scaled to V=7.2 mag, and thus will over-predict count rates for most of the targets (see Observation Description).</i>									3	(COS.sp.100 5139)	(10) HD22359	COS/FUV, TIME-TAG, PSA	G130M 1222 A	BUFFER-TIME=47 4; FP-POS=4			574 Secs (574 Secs) [==>]	[1]	<i>Comments: Note: ETC simulation (for G130M-1291, so as to include Ly-alpha) is for an "extreme" FUV spectrum, scaled to V=7.2 mag, and thus will over-predict count rates for most of the targets (see Observation Description).</i>									4	(COS.sp.100 5139)	(10) HD22359	COS/FUV, TIME-TAG, PSA	G130M 1291 A	BUFFER-TIME=47 4; FP-POS=3			574 Secs (574 Secs) [==>]	[1]	<i>Comments: Note: ETC simulation (for G130M-1291, so as to include Ly-alpha) is for an "extreme" FUV spectrum, scaled to V=7.2 mag, and thus will over-predict count rates for most of the targets (see Observation Description).</i>									5	(COS.sp.100 5139)	(10) HD22359	COS/FUV, TIME-TAG, PSA	G130M 1291 A	BUFFER-TIME=47 4; FP-POS=4			574 Secs (574 Secs) [==>]	[1]	<i>Comments: Note: ETC simulation (for G130M-1291, so as to include Ly-alpha) is for an "extreme" FUV spectrum, scaled to V=7.2 mag, and thus will over-predict count rates for most of the targets (see Observation Description).</i>													
	#	Label (ETC Run)	Target	Config,Mode,Aperture	Spectral Els.	Opt. Params.	Special Reqs.	Groups	Exp. Time (Total)/[Actual Dur.]	Orbit																																																																																												
	1	(COS.ta.100 4272)	(10) HD22359	COS/NUV, ACQ/IMAGE, BOA	MIRRORB				37 Secs (37 Secs) [==>]	[1]																																																																																												
	2	(COS.sp.100 5139)	(10) HD22359	COS/FUV, TIME-TAG, PSA	G130M 1222 A	BUFFER-TIME=47 4; FP-POS=3			574 Secs (574 Secs) [==>]	[1]																																																																																												
	<i>Comments: Note: ETC simulation (for G130M-1291, so as to include Ly-alpha) is for an "extreme" FUV spectrum, scaled to V=7.2 mag, and thus will over-predict count rates for most of the targets (see Observation Description).</i>																																																																																																					
	3	(COS.sp.100 5139)	(10) HD22359	COS/FUV, TIME-TAG, PSA	G130M 1222 A	BUFFER-TIME=47 4; FP-POS=4			574 Secs (574 Secs) [==>]	[1]																																																																																												
<i>Comments: Note: ETC simulation (for G130M-1291, so as to include Ly-alpha) is for an "extreme" FUV spectrum, scaled to V=7.2 mag, and thus will over-predict count rates for most of the targets (see Observation Description).</i>																																																																																																						
4	(COS.sp.100 5139)	(10) HD22359	COS/FUV, TIME-TAG, PSA	G130M 1291 A	BUFFER-TIME=47 4; FP-POS=3			574 Secs (574 Secs) [==>]	[1]																																																																																													
<i>Comments: Note: ETC simulation (for G130M-1291, so as to include Ly-alpha) is for an "extreme" FUV spectrum, scaled to V=7.2 mag, and thus will over-predict count rates for most of the targets (see Observation Description).</i>																																																																																																						
5	(COS.sp.100 5139)	(10) HD22359	COS/FUV, TIME-TAG, PSA	G130M 1291 A	BUFFER-TIME=47 4; FP-POS=4			574 Secs (574 Secs) [==>]	[1]																																																																																													
<i>Comments: Note: ETC simulation (for G130M-1291, so as to include Ly-alpha) is for an "extreme" FUV spectrum, scaled to V=7.2 mag, and thus will over-predict count rates for most of the targets (see Observation Description).</i>																																																																																																						

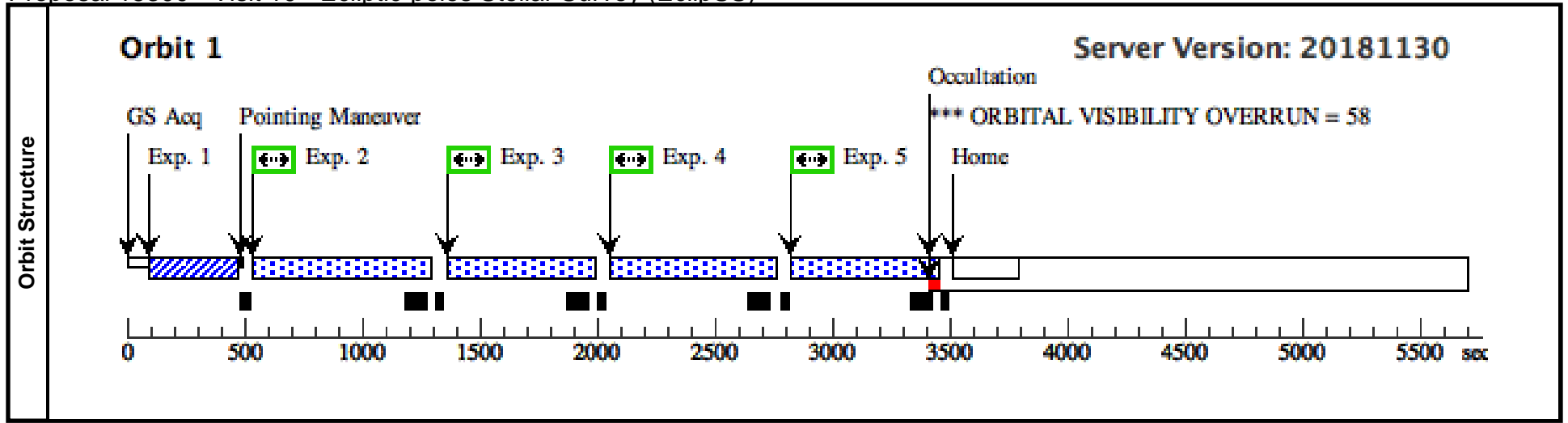

Proposal 15300 - Visit 11 - Ecliptic-poles Stellar Survey (EclipSS)

Thu Dec 13 22:02:07 GMT 2018

Visit	Proposal 15300, Visit 11, failed Diagnostic Status: Warning Scientific Instruments: COS/FUV, COS/NUV Special Requirements: (none)									
	(Visit 11) Warning (Form): For the best data quality, it is strongly recommended that the maximum number of allowed FP-POS positions is used when observing at a given COS CENWAVE setting. See full description for details. (Visit 11) Warning (Orbit Planner): ORBITAL VISIBILITY OVERRUN									
Diagnosics										
Fixed Targets	#	Name	Target Coordinates	Targ. Coord. Corrections	Fluxes	Miscellaneous				
	(11)	HD29255	RA: 04 29 58.6452 (67.4943550d) Dec: -72 16 31.78 (-72.27549d) Equinox: J2000	Proper Motion RA: 4.57 mas/yr Proper Motion Dec: 9.59 mas/yr Parallax: 0.01206" Epoch of Position: 2000 Radial Velocity: 0.0 km/sec	V=8.36+/-0.1 sptyp= F6V; (B-V)= 0.48 mag; dist= 86 pc	Reference Frame: ICRS				
Comments: Category=STAR Description=[F3-F9] Extended=NO										
Exposures	#	Label (ETC Run)	Target	Config,Mode,Aperture	Spectral Els.	Opt. Params.	Special Reqs.	Groups	Exp. Time (Total)/[Actual Dur.]	Orbit
	1	(COS.ta.100 4273)	(11) HD29255	COS/NUV, ACQ/IMAGE, BOA	MIRRORA				4 Secs (4 Secs) [==>]	[1]
2	(COS.sp.100 5139)	(11) HD29255	COS/FUV, TIME-TAG, PSA	G130M 1222 A	9; FP-POS=3			619 Secs (619 Secs) [==>]	[1]	
Comments: Note: ETC simulation (for G130M-1291, so as to include Ly-alpha) is for an "extreme" FUV spectrum, scaled to V=7.2 mag, and thus will over-predict count rates for most of the targets (see Observation Description).										
3	(COS.sp.100 5139)	(11) HD29255	COS/FUV, TIME-TAG, PSA	G130M 1222 A	9; FP-POS=4			619 Secs (619 Secs) [==>]	[1]	
Comments: Note: ETC simulation (for G130M-1291, so as to include Ly-alpha) is for an "extreme" FUV spectrum, scaled to V=7.2 mag, and thus will over-predict count rates for most of the targets (see Observation Description).										
4	(COS.sp.100 5139)	(11) HD29255	COS/FUV, TIME-TAG, PSA	G130M 1291 A	9; FP-POS=3			619 Secs (619 Secs) [==>]	[1]	
Comments: Note: ETC simulation (for G130M-1291, so as to include Ly-alpha) is for an "extreme" FUV spectrum, scaled to V=7.2 mag, and thus will over-predict count rates for most of the targets (see Observation Description).										
5	(COS.sp.100 5139)	(11) HD29255	COS/FUV, TIME-TAG, PSA	G130M 1291 A	9; FP-POS=4			619 Secs (619 Secs) [==>]	[1]	
Comments: Note: ETC simulation (for G130M-1291, so as to include Ly-alpha) is for an "extreme" FUV spectrum, scaled to V=7.2 mag, and thus will over-predict count rates for most of the targets (see Observation Description).										

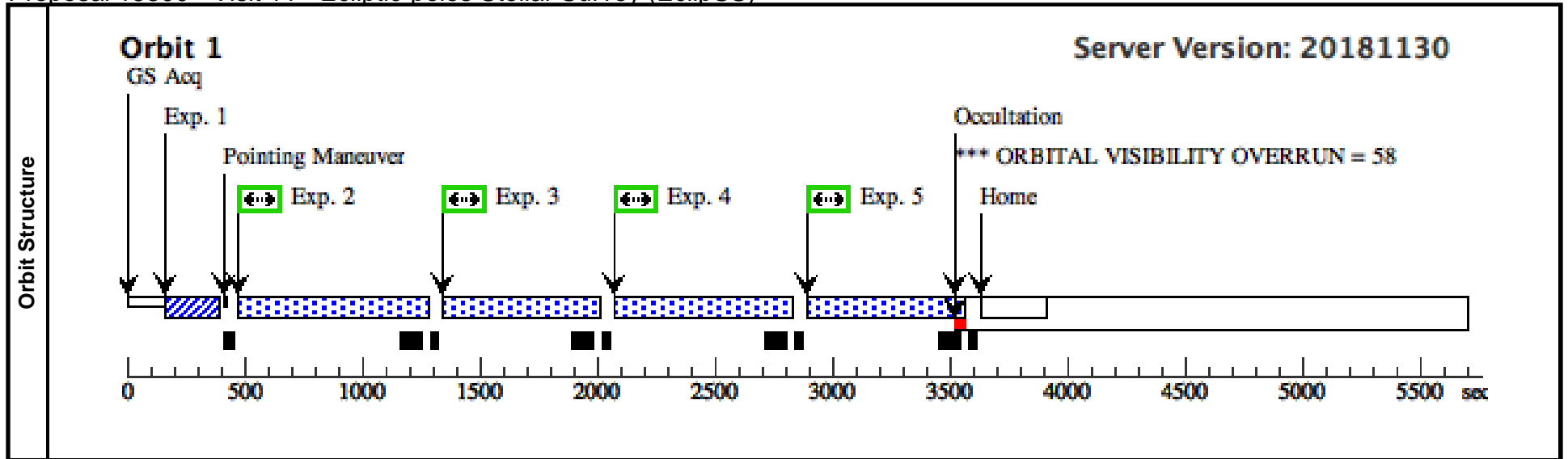

Proposal 15300 - Visit 51 - Ecliptic-poles Stellar Survey (EclipSS)

Thu Dec 13 22:02:07 GMT 2018

Visit	Proposal 15300, Visit 51, completed Diagnostic Status: Warning Scientific Instruments: COS/FUV, COS/NUV Special Requirements: (none) <i>Comments: Repeat for failed visit 11.</i>																																																																																																									
	(Visit 51) Warning (Form): For the best data quality, it is strongly recommended that the maximum number of allowed FP-POS positions is used when observing at a given COS CENWAVE setting. See full description for details.																																																																																																									
Diagnostics																																																																																																										
Fixed Targets	<table border="1"> <thead> <tr> <th>#</th> <th>Name</th> <th>Target Coordinates</th> <th>Targ. Coord. Corrections</th> <th>Fluxes</th> <th>Miscellaneous</th> </tr> </thead> <tbody> <tr> <td>(11)</td> <td>HD29255</td> <td>RA: 04 29 58.6452 (67.4943550d) Dec: -72 16 31.78 (-72.27549d) Equinox: J2000</td> <td>Proper Motion RA: 4.57 mas/yr Proper Motion Dec: 9.59 mas/yr Parallax: 0.01206" Epoch of Position: 2000 Radial Velocity: 0.0 km/sec</td> <td>V=8.36+/-0.1 sptyp= F6V; (B-V)= 0.48 mag; dist= 86 pc</td> <td>Reference Frame: ICRS</td> </tr> </tbody> </table>	#	Name	Target Coordinates	Targ. Coord. Corrections	Fluxes	Miscellaneous	(11)	HD29255	RA: 04 29 58.6452 (67.4943550d) Dec: -72 16 31.78 (-72.27549d) Equinox: J2000	Proper Motion RA: 4.57 mas/yr Proper Motion Dec: 9.59 mas/yr Parallax: 0.01206" Epoch of Position: 2000 Radial Velocity: 0.0 km/sec	V=8.36+/-0.1 sptyp= F6V; (B-V)= 0.48 mag; dist= 86 pc	Reference Frame: ICRS	<i>Comments:</i> Category=STAR Description=[F3-F9] Extended=NO																																																																																												
	#	Name	Target Coordinates	Targ. Coord. Corrections	Fluxes	Miscellaneous																																																																																																				
(11)	HD29255	RA: 04 29 58.6452 (67.4943550d) Dec: -72 16 31.78 (-72.27549d) Equinox: J2000	Proper Motion RA: 4.57 mas/yr Proper Motion Dec: 9.59 mas/yr Parallax: 0.01206" Epoch of Position: 2000 Radial Velocity: 0.0 km/sec	V=8.36+/-0.1 sptyp= F6V; (B-V)= 0.48 mag; dist= 86 pc	Reference Frame: ICRS																																																																																																					
Exposures	<table border="1"> <thead> <tr> <th>#</th> <th>Label (ETC Run)</th> <th>Target</th> <th>Config,Mode,Aperture</th> <th>Spectral Els.</th> <th>Opt. Params.</th> <th>Special Reqs.</th> <th>Groups</th> <th>Exp. Time (Total)/[Actual Dur.]</th> <th>Orbit</th> </tr> </thead> <tbody> <tr> <td>1</td> <td>(COS.ta.100 4273)</td> <td>(11) HD29255</td> <td>COS/NUV, ACQ/IMAGE, BOA</td> <td>MIRRORA</td> <td></td> <td></td> <td></td> <td>4 Secs (4 Secs) [==>]</td> <td>[1]</td> </tr> <tr> <td>2</td> <td>(COS.sp.100 5139)</td> <td>(11) HD29255</td> <td>COS/FUV, TIME-TAG, PSA</td> <td>G130M 1222 A</td> <td>BUFFER-TIME=51 9; FP-POS=3</td> <td></td> <td></td> <td>619 Secs (619 Secs) [==>]</td> <td>[1]</td> </tr> <tr> <td colspan="10"> <i>Comments: Note: ETC simulation (for G130M-1291, so as to include Ly-alpha) is for an "extreme" FUV spectrum, scaled to V=7.2 mag, and thus will over-predict count rates for most of the targets (see Observation Description).</i> </td> </tr> <tr> <td>3</td> <td>(COS.sp.100 5139)</td> <td>(11) HD29255</td> <td>COS/FUV, TIME-TAG, PSA</td> <td>G130M 1222 A</td> <td>BUFFER-TIME=51 9; FP-POS=4</td> <td></td> <td></td> <td>619 Secs (619 Secs) [==>]</td> <td>[1]</td> </tr> <tr> <td colspan="10"> <i>Comments: Note: ETC simulation (for G130M-1291, so as to include Ly-alpha) is for an "extreme" FUV spectrum, scaled to V=7.2 mag, and thus will over-predict count rates for most of the targets (see Observation Description).</i> </td> </tr> <tr> <td>4</td> <td>(COS.sp.100 5139)</td> <td>(11) HD29255</td> <td>COS/FUV, TIME-TAG, PSA</td> <td>G130M 1291 A</td> <td>BUFFER-TIME=51 9; FP-POS=3</td> <td></td> <td></td> <td>619 Secs (619 Secs) [==>]</td> <td>[1]</td> </tr> <tr> <td colspan="10"> <i>Comments: Note: ETC simulation (for G130M-1291, so as to include Ly-alpha) is for an "extreme" FUV spectrum, scaled to V=7.2 mag, and thus will over-predict count rates for most of the targets (see Observation Description).</i> </td> </tr> <tr> <td>5</td> <td>(COS.sp.100 5139)</td> <td>(11) HD29255</td> <td>COS/FUV, TIME-TAG, PSA</td> <td>G130M 1291 A</td> <td>BUFFER-TIME=51 9; FP-POS=4</td> <td></td> <td></td> <td>619 Secs (619 Secs) [==>]</td> <td>[1]</td> </tr> <tr> <td colspan="10"> <i>Comments: Note: ETC simulation (for G130M-1291, so as to include Ly-alpha) is for an "extreme" FUV spectrum, scaled to V=7.2 mag, and thus will over-predict count rates for most of the targets (see Observation Description).</i> </td> </tr> </tbody> </table>	#	Label (ETC Run)	Target	Config,Mode,Aperture	Spectral Els.	Opt. Params.	Special Reqs.	Groups	Exp. Time (Total)/[Actual Dur.]	Orbit	1	(COS.ta.100 4273)	(11) HD29255	COS/NUV, ACQ/IMAGE, BOA	MIRRORA				4 Secs (4 Secs) [==>]	[1]	2	(COS.sp.100 5139)	(11) HD29255	COS/FUV, TIME-TAG, PSA	G130M 1222 A	BUFFER-TIME=51 9; FP-POS=3			619 Secs (619 Secs) [==>]	[1]	<i>Comments: Note: ETC simulation (for G130M-1291, so as to include Ly-alpha) is for an "extreme" FUV spectrum, scaled to V=7.2 mag, and thus will over-predict count rates for most of the targets (see Observation Description).</i>										3	(COS.sp.100 5139)	(11) HD29255	COS/FUV, TIME-TAG, PSA	G130M 1222 A	BUFFER-TIME=51 9; FP-POS=4			619 Secs (619 Secs) [==>]	[1]	<i>Comments: Note: ETC simulation (for G130M-1291, so as to include Ly-alpha) is for an "extreme" FUV spectrum, scaled to V=7.2 mag, and thus will over-predict count rates for most of the targets (see Observation Description).</i>										4	(COS.sp.100 5139)	(11) HD29255	COS/FUV, TIME-TAG, PSA	G130M 1291 A	BUFFER-TIME=51 9; FP-POS=3			619 Secs (619 Secs) [==>]	[1]	<i>Comments: Note: ETC simulation (for G130M-1291, so as to include Ly-alpha) is for an "extreme" FUV spectrum, scaled to V=7.2 mag, and thus will over-predict count rates for most of the targets (see Observation Description).</i>										5	(COS.sp.100 5139)	(11) HD29255	COS/FUV, TIME-TAG, PSA	G130M 1291 A	BUFFER-TIME=51 9; FP-POS=4			619 Secs (619 Secs) [==>]	[1]	<i>Comments: Note: ETC simulation (for G130M-1291, so as to include Ly-alpha) is for an "extreme" FUV spectrum, scaled to V=7.2 mag, and thus will over-predict count rates for most of the targets (see Observation Description).</i>														
	#	Label (ETC Run)	Target	Config,Mode,Aperture	Spectral Els.	Opt. Params.	Special Reqs.	Groups	Exp. Time (Total)/[Actual Dur.]	Orbit																																																																																																
	1	(COS.ta.100 4273)	(11) HD29255	COS/NUV, ACQ/IMAGE, BOA	MIRRORA				4 Secs (4 Secs) [==>]	[1]																																																																																																
	2	(COS.sp.100 5139)	(11) HD29255	COS/FUV, TIME-TAG, PSA	G130M 1222 A	BUFFER-TIME=51 9; FP-POS=3			619 Secs (619 Secs) [==>]	[1]																																																																																																
	<i>Comments: Note: ETC simulation (for G130M-1291, so as to include Ly-alpha) is for an "extreme" FUV spectrum, scaled to V=7.2 mag, and thus will over-predict count rates for most of the targets (see Observation Description).</i>																																																																																																									
	3	(COS.sp.100 5139)	(11) HD29255	COS/FUV, TIME-TAG, PSA	G130M 1222 A	BUFFER-TIME=51 9; FP-POS=4			619 Secs (619 Secs) [==>]	[1]																																																																																																
<i>Comments: Note: ETC simulation (for G130M-1291, so as to include Ly-alpha) is for an "extreme" FUV spectrum, scaled to V=7.2 mag, and thus will over-predict count rates for most of the targets (see Observation Description).</i>																																																																																																										
4	(COS.sp.100 5139)	(11) HD29255	COS/FUV, TIME-TAG, PSA	G130M 1291 A	BUFFER-TIME=51 9; FP-POS=3			619 Secs (619 Secs) [==>]	[1]																																																																																																	
<i>Comments: Note: ETC simulation (for G130M-1291, so as to include Ly-alpha) is for an "extreme" FUV spectrum, scaled to V=7.2 mag, and thus will over-predict count rates for most of the targets (see Observation Description).</i>																																																																																																										
5	(COS.sp.100 5139)	(11) HD29255	COS/FUV, TIME-TAG, PSA	G130M 1291 A	BUFFER-TIME=51 9; FP-POS=4			619 Secs (619 Secs) [==>]	[1]																																																																																																	
<i>Comments: Note: ETC simulation (for G130M-1291, so as to include Ly-alpha) is for an "extreme" FUV spectrum, scaled to V=7.2 mag, and thus will over-predict count rates for most of the targets (see Observation Description).</i>																																																																																																										

Proposal 15300 - Visit 12 - Ecliptic-poles Stellar Survey (EclipSS)

Thu Dec 13 22:02:07 GMT 2018

Visit	Proposal 15300, Visit 12, completed Diagnostic Status: Warning Scientific Instruments: COS/FUV, COS/NUV Special Requirements: (none)																																																																																																									
	(Visit 12) Warning (Form): For the best data quality, it is strongly recommended that the maximum number of allowed FP-POS positions is used when observing at a given COS CENWAVE setting. See full description for details. (Visit 12) Warning (Orbit Planner): ORBITAL VISIBILITY OVERRUN																																																																																																									
Diagnosics																																																																																																										
Fixed Targets	<table border="1"> <thead> <tr> <th>#</th> <th>Name</th> <th>Target Coordinates</th> <th>Targ. Coord. Corrections</th> <th>Fluxes</th> <th>Miscellaneous</th> </tr> </thead> <tbody> <tr> <td>(12)</td> <td>HD165700</td> <td>RA: 18 04 0.4652 (271.0019383d) Dec: +55 16 23.44 (55.27318d) Equinox: J2000</td> <td>Proper Motion RA: -50.15 mas/yr Proper Motion Dec: -125.80 mas/yr Parallax: 0.01162" Epoch of Position: 2000 Radial Velocity: 0.0 km/sec</td> <td>V=7.80+/-0.1 sptyp= F8V; (B-V)= 0.41 mag; dist= 89 pc</td> <td>Reference Frame: ICRS</td> </tr> </tbody> </table>	#	Name	Target Coordinates	Targ. Coord. Corrections	Fluxes	Miscellaneous	(12)	HD165700	RA: 18 04 0.4652 (271.0019383d) Dec: +55 16 23.44 (55.27318d) Equinox: J2000	Proper Motion RA: -50.15 mas/yr Proper Motion Dec: -125.80 mas/yr Parallax: 0.01162" Epoch of Position: 2000 Radial Velocity: 0.0 km/sec	V=7.80+/-0.1 sptyp= F8V; (B-V)= 0.41 mag; dist= 89 pc	Reference Frame: ICRS	Comments: Category=STAR Description=[F3-F9] Extended=NO																																																																																												
	#	Name	Target Coordinates	Targ. Coord. Corrections	Fluxes	Miscellaneous																																																																																																				
(12)	HD165700	RA: 18 04 0.4652 (271.0019383d) Dec: +55 16 23.44 (55.27318d) Equinox: J2000	Proper Motion RA: -50.15 mas/yr Proper Motion Dec: -125.80 mas/yr Parallax: 0.01162" Epoch of Position: 2000 Radial Velocity: 0.0 km/sec	V=7.80+/-0.1 sptyp= F8V; (B-V)= 0.41 mag; dist= 89 pc	Reference Frame: ICRS																																																																																																					
Exposures	<table border="1"> <thead> <tr> <th>#</th> <th>Label (ETC Run)</th> <th>Target</th> <th>Config,Mode,Aperture</th> <th>Spectral Els.</th> <th>Opt. Params.</th> <th>Special Reqs.</th> <th>Groups</th> <th>Exp. Time (Total)/[Actual Dur.]</th> <th>Orbit</th> </tr> </thead> <tbody> <tr> <td>1</td> <td>(COS.ta.100 4275)</td> <td>(12) HD165700</td> <td>COS/NUV, ACQ/IMAGE, BOA</td> <td>MIRRORB</td> <td></td> <td></td> <td></td> <td>54 Secs (54 Secs) [==>]</td> <td>[1]</td> </tr> <tr> <td>2</td> <td>(COS.sp.100 5139)</td> <td>(12) HD165700</td> <td>COS/FUV, TIME-TAG, PSA</td> <td>G130M 1222 A</td> <td>BUFFER-TIME=46 0; FP-POS=3</td> <td></td> <td></td> <td>560 Secs (560 Secs) [==>]</td> <td>[1]</td> </tr> <tr> <td colspan="10"> Comments: Note: ETC simulation (for G130M-1291, so as to include Ly-alpha) is for an "extreme" FUV spectrum, scaled to V=7.2 mag, and thus will over-predict count rates for most of the targets (see Observation Description). </td> </tr> <tr> <td>3</td> <td>(COS.sp.100 5139)</td> <td>(12) HD165700</td> <td>COS/FUV, TIME-TAG, PSA</td> <td>G130M 1222 A</td> <td>BUFFER-TIME=46 0; FP-POS=4</td> <td></td> <td></td> <td>560 Secs (560 Secs) [==>]</td> <td>[1]</td> </tr> <tr> <td colspan="10"> Comments: Note: ETC simulation (for G130M-1291, so as to include Ly-alpha) is for an "extreme" FUV spectrum, scaled to V=7.2 mag, and thus will over-predict count rates for most of the targets (see Observation Description). </td> </tr> <tr> <td>4</td> <td>(COS.sp.100 5139)</td> <td>(12) HD165700</td> <td>COS/FUV, TIME-TAG, PSA</td> <td>G130M 1291 A</td> <td>BUFFER-TIME=46 0; FP-POS=3</td> <td></td> <td></td> <td>560 Secs (560 Secs) [==>]</td> <td>[1]</td> </tr> <tr> <td colspan="10"> Comments: Note: ETC simulation (for G130M-1291, so as to include Ly-alpha) is for an "extreme" FUV spectrum, scaled to V=7.2 mag, and thus will over-predict count rates for most of the targets (see Observation Description). </td> </tr> <tr> <td>5</td> <td>(COS.sp.100 5139)</td> <td>(12) HD165700</td> <td>COS/FUV, TIME-TAG, PSA</td> <td>G130M 1291 A</td> <td>BUFFER-TIME=46 0; FP-POS=4</td> <td></td> <td></td> <td>560 Secs (560 Secs) [==>]</td> <td>[1]</td> </tr> <tr> <td colspan="10"> Comments: Note: ETC simulation (for G130M-1291, so as to include Ly-alpha) is for an "extreme" FUV spectrum, scaled to V=7.2 mag, and thus will over-predict count rates for most of the targets (see Observation Description). </td> </tr> </tbody> </table>	#	Label (ETC Run)	Target	Config,Mode,Aperture	Spectral Els.	Opt. Params.	Special Reqs.	Groups	Exp. Time (Total)/[Actual Dur.]	Orbit	1	(COS.ta.100 4275)	(12) HD165700	COS/NUV, ACQ/IMAGE, BOA	MIRRORB				54 Secs (54 Secs) [==>]	[1]	2	(COS.sp.100 5139)	(12) HD165700	COS/FUV, TIME-TAG, PSA	G130M 1222 A	BUFFER-TIME=46 0; FP-POS=3			560 Secs (560 Secs) [==>]	[1]	Comments: Note: ETC simulation (for G130M-1291, so as to include Ly-alpha) is for an "extreme" FUV spectrum, scaled to V=7.2 mag, and thus will over-predict count rates for most of the targets (see Observation Description).										3	(COS.sp.100 5139)	(12) HD165700	COS/FUV, TIME-TAG, PSA	G130M 1222 A	BUFFER-TIME=46 0; FP-POS=4			560 Secs (560 Secs) [==>]	[1]	Comments: Note: ETC simulation (for G130M-1291, so as to include Ly-alpha) is for an "extreme" FUV spectrum, scaled to V=7.2 mag, and thus will over-predict count rates for most of the targets (see Observation Description).										4	(COS.sp.100 5139)	(12) HD165700	COS/FUV, TIME-TAG, PSA	G130M 1291 A	BUFFER-TIME=46 0; FP-POS=3			560 Secs (560 Secs) [==>]	[1]	Comments: Note: ETC simulation (for G130M-1291, so as to include Ly-alpha) is for an "extreme" FUV spectrum, scaled to V=7.2 mag, and thus will over-predict count rates for most of the targets (see Observation Description).										5	(COS.sp.100 5139)	(12) HD165700	COS/FUV, TIME-TAG, PSA	G130M 1291 A	BUFFER-TIME=46 0; FP-POS=4			560 Secs (560 Secs) [==>]	[1]	Comments: Note: ETC simulation (for G130M-1291, so as to include Ly-alpha) is for an "extreme" FUV spectrum, scaled to V=7.2 mag, and thus will over-predict count rates for most of the targets (see Observation Description).														
	#	Label (ETC Run)	Target	Config,Mode,Aperture	Spectral Els.	Opt. Params.	Special Reqs.	Groups	Exp. Time (Total)/[Actual Dur.]	Orbit																																																																																																
	1	(COS.ta.100 4275)	(12) HD165700	COS/NUV, ACQ/IMAGE, BOA	MIRRORB				54 Secs (54 Secs) [==>]	[1]																																																																																																
	2	(COS.sp.100 5139)	(12) HD165700	COS/FUV, TIME-TAG, PSA	G130M 1222 A	BUFFER-TIME=46 0; FP-POS=3			560 Secs (560 Secs) [==>]	[1]																																																																																																
	Comments: Note: ETC simulation (for G130M-1291, so as to include Ly-alpha) is for an "extreme" FUV spectrum, scaled to V=7.2 mag, and thus will over-predict count rates for most of the targets (see Observation Description).																																																																																																									
	3	(COS.sp.100 5139)	(12) HD165700	COS/FUV, TIME-TAG, PSA	G130M 1222 A	BUFFER-TIME=46 0; FP-POS=4			560 Secs (560 Secs) [==>]	[1]																																																																																																
Comments: Note: ETC simulation (for G130M-1291, so as to include Ly-alpha) is for an "extreme" FUV spectrum, scaled to V=7.2 mag, and thus will over-predict count rates for most of the targets (see Observation Description).																																																																																																										
4	(COS.sp.100 5139)	(12) HD165700	COS/FUV, TIME-TAG, PSA	G130M 1291 A	BUFFER-TIME=46 0; FP-POS=3			560 Secs (560 Secs) [==>]	[1]																																																																																																	
Comments: Note: ETC simulation (for G130M-1291, so as to include Ly-alpha) is for an "extreme" FUV spectrum, scaled to V=7.2 mag, and thus will over-predict count rates for most of the targets (see Observation Description).																																																																																																										
5	(COS.sp.100 5139)	(12) HD165700	COS/FUV, TIME-TAG, PSA	G130M 1291 A	BUFFER-TIME=46 0; FP-POS=4			560 Secs (560 Secs) [==>]	[1]																																																																																																	
Comments: Note: ETC simulation (for G130M-1291, so as to include Ly-alpha) is for an "extreme" FUV spectrum, scaled to V=7.2 mag, and thus will over-predict count rates for most of the targets (see Observation Description).																																																																																																										

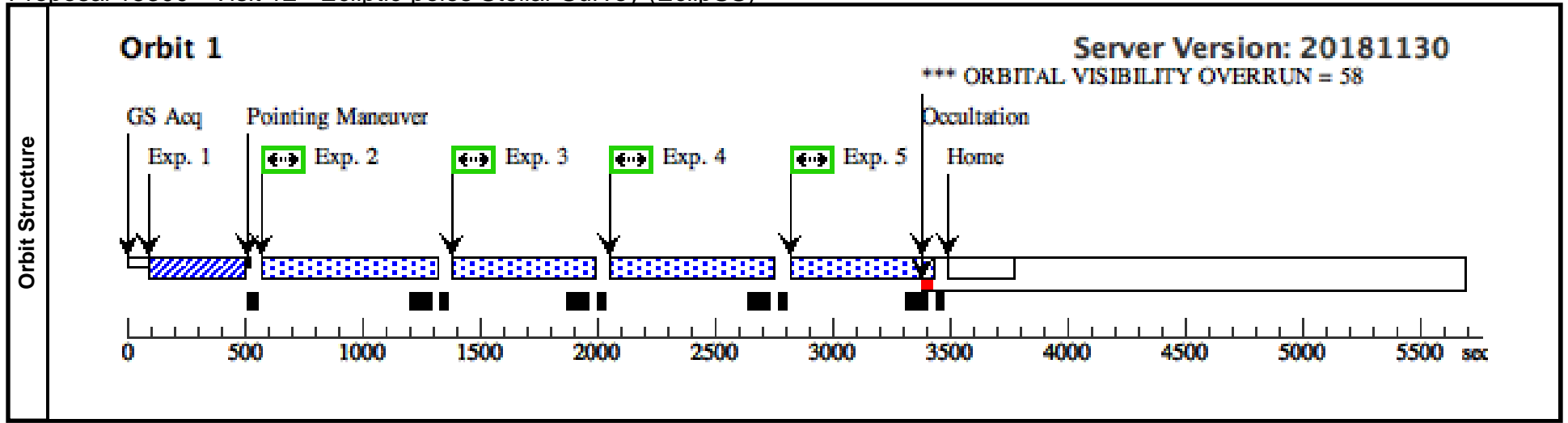

Proposal 15300 - Visit 13 - Ecliptic-poles Stellar Survey (EclipSS)

Thu Dec 13 22:02:07 GMT 2018

Visit	Proposal 15300, Visit 13, completed Diagnostic Status: Warning Scientific Instruments: COS/FUV, COS/NUV Special Requirements: (none)																																																																																																									
	(Visit 13) Warning (Form): For the best data quality, it is strongly recommended that the maximum number of allowed FP-POS positions is used when observing at a given COS CENWAVE setting. See full description for details. (Visit 13) Warning (Orbit Planner): ORBITAL VISIBILITY OVERRUN																																																																																																									
Diagnosics																																																																																																										
Fixed Targets	<table border="1"> <thead> <tr> <th>#</th> <th>Name</th> <th>Target Coordinates</th> <th>Targ. Coord. Corrections</th> <th>Fluxes</th> <th>Miscellaneous</th> </tr> </thead> <tbody> <tr> <td>(13)</td> <td>HD185239</td> <td>RA: 19 34 51.8814 (293.7161725d) Dec: +57 46 21.47 (57.77263d) Equinox: J2000</td> <td>Proper Motion RA: -34.51 mas/yr Proper Motion Dec: 23.53 mas/yr Parallax: 0.01183" Epoch of Position: 2000 Radial Velocity: 0.0 km/sec</td> <td>V=8.16+/-0.1 sptyp= F8V; (B-V)= 0.41 mag; dist= 81 pc</td> <td>Reference Frame: ICRS</td> </tr> </tbody> </table>	#	Name	Target Coordinates	Targ. Coord. Corrections	Fluxes	Miscellaneous	(13)	HD185239	RA: 19 34 51.8814 (293.7161725d) Dec: +57 46 21.47 (57.77263d) Equinox: J2000	Proper Motion RA: -34.51 mas/yr Proper Motion Dec: 23.53 mas/yr Parallax: 0.01183" Epoch of Position: 2000 Radial Velocity: 0.0 km/sec	V=8.16+/-0.1 sptyp= F8V; (B-V)= 0.41 mag; dist= 81 pc	Reference Frame: ICRS	Comments: Category=STAR Description=[F3-F9] Extended=NO																																																																																												
	#	Name	Target Coordinates	Targ. Coord. Corrections	Fluxes	Miscellaneous																																																																																																				
(13)	HD185239	RA: 19 34 51.8814 (293.7161725d) Dec: +57 46 21.47 (57.77263d) Equinox: J2000	Proper Motion RA: -34.51 mas/yr Proper Motion Dec: 23.53 mas/yr Parallax: 0.01183" Epoch of Position: 2000 Radial Velocity: 0.0 km/sec	V=8.16+/-0.1 sptyp= F8V; (B-V)= 0.41 mag; dist= 81 pc	Reference Frame: ICRS																																																																																																					
Exposures	<table border="1"> <thead> <tr> <th>#</th> <th>Label (ETC Run)</th> <th>Target</th> <th>Config,Mode,Aperture</th> <th>Spectral Els.</th> <th>Opt. Params.</th> <th>Special Reqs.</th> <th>Groups</th> <th>Exp. Time (Total)/[Actual Dur.]</th> <th>Orbit</th> </tr> </thead> <tbody> <tr> <td>1</td> <td>(COS.ta.100 4277)</td> <td>(13) HD185239</td> <td>COS/NUV, ACQ/IMAGE, BOA</td> <td>MIRRORA</td> <td></td> <td></td> <td></td> <td>6 Secs (6 Secs) [==>]</td> <td>[1]</td> </tr> <tr> <td>2</td> <td>(COS.sp.100 5139)</td> <td>(13) HD185239</td> <td>COS/FUV, TIME-TAG, PSA</td> <td>G130M 1222 A</td> <td>BUFFER-TIME=48 4; FP-POS=3</td> <td></td> <td></td> <td>584 Secs (584 Secs) [==>]</td> <td>[1]</td> </tr> <tr> <td colspan="10"> Comments: Note: ETC simulation (for G130M-1291, so as to include Ly-alpha) is for an "extreme" FUV spectrum, scaled to V=7.2 mag, and thus will over-predict count rates for most of the targets (see Observation Description). </td> </tr> <tr> <td>3</td> <td>(COS.sp.100 5139)</td> <td>(13) HD185239</td> <td>COS/FUV, TIME-TAG, PSA</td> <td>G130M 1222 A</td> <td>BUFFER-TIME=48 4; FP-POS=4</td> <td></td> <td></td> <td>584 Secs (584 Secs) [==>]</td> <td>[1]</td> </tr> <tr> <td colspan="10"> Comments: Note: ETC simulation (for G130M-1291, so as to include Ly-alpha) is for an "extreme" FUV spectrum, scaled to V=7.2 mag, and thus will over-predict count rates for most of the targets (see Observation Description). </td> </tr> <tr> <td>4</td> <td>(COS.sp.100 5139)</td> <td>(13) HD185239</td> <td>COS/FUV, TIME-TAG, PSA</td> <td>G130M 1291 A</td> <td>BUFFER-TIME=48 4; FP-POS=3</td> <td></td> <td></td> <td>584 Secs (584 Secs) [==>]</td> <td>[1]</td> </tr> <tr> <td colspan="10"> Comments: Note: ETC simulation (for G130M-1291, so as to include Ly-alpha) is for an "extreme" FUV spectrum, scaled to V=7.2 mag, and thus will over-predict count rates for most of the targets (see Observation Description). </td> </tr> <tr> <td>5</td> <td>(COS.sp.100 5139)</td> <td>(13) HD185239</td> <td>COS/FUV, TIME-TAG, PSA</td> <td>G130M 1291 A</td> <td>BUFFER-TIME=48 4; FP-POS=4</td> <td></td> <td></td> <td>584 Secs (584 Secs) [==>]</td> <td>[1]</td> </tr> <tr> <td colspan="10"> Comments: Note: ETC simulation (for G130M-1291, so as to include Ly-alpha) is for an "extreme" FUV spectrum, scaled to V=7.2 mag, and thus will over-predict count rates for most of the targets (see Observation Description). </td> </tr> </tbody> </table>	#	Label (ETC Run)	Target	Config,Mode,Aperture	Spectral Els.	Opt. Params.	Special Reqs.	Groups	Exp. Time (Total)/[Actual Dur.]	Orbit	1	(COS.ta.100 4277)	(13) HD185239	COS/NUV, ACQ/IMAGE, BOA	MIRRORA				6 Secs (6 Secs) [==>]	[1]	2	(COS.sp.100 5139)	(13) HD185239	COS/FUV, TIME-TAG, PSA	G130M 1222 A	BUFFER-TIME=48 4; FP-POS=3			584 Secs (584 Secs) [==>]	[1]	Comments: Note: ETC simulation (for G130M-1291, so as to include Ly-alpha) is for an "extreme" FUV spectrum, scaled to V=7.2 mag, and thus will over-predict count rates for most of the targets (see Observation Description).										3	(COS.sp.100 5139)	(13) HD185239	COS/FUV, TIME-TAG, PSA	G130M 1222 A	BUFFER-TIME=48 4; FP-POS=4			584 Secs (584 Secs) [==>]	[1]	Comments: Note: ETC simulation (for G130M-1291, so as to include Ly-alpha) is for an "extreme" FUV spectrum, scaled to V=7.2 mag, and thus will over-predict count rates for most of the targets (see Observation Description).										4	(COS.sp.100 5139)	(13) HD185239	COS/FUV, TIME-TAG, PSA	G130M 1291 A	BUFFER-TIME=48 4; FP-POS=3			584 Secs (584 Secs) [==>]	[1]	Comments: Note: ETC simulation (for G130M-1291, so as to include Ly-alpha) is for an "extreme" FUV spectrum, scaled to V=7.2 mag, and thus will over-predict count rates for most of the targets (see Observation Description).										5	(COS.sp.100 5139)	(13) HD185239	COS/FUV, TIME-TAG, PSA	G130M 1291 A	BUFFER-TIME=48 4; FP-POS=4			584 Secs (584 Secs) [==>]	[1]	Comments: Note: ETC simulation (for G130M-1291, so as to include Ly-alpha) is for an "extreme" FUV spectrum, scaled to V=7.2 mag, and thus will over-predict count rates for most of the targets (see Observation Description).														
	#	Label (ETC Run)	Target	Config,Mode,Aperture	Spectral Els.	Opt. Params.	Special Reqs.	Groups	Exp. Time (Total)/[Actual Dur.]	Orbit																																																																																																
	1	(COS.ta.100 4277)	(13) HD185239	COS/NUV, ACQ/IMAGE, BOA	MIRRORA				6 Secs (6 Secs) [==>]	[1]																																																																																																
	2	(COS.sp.100 5139)	(13) HD185239	COS/FUV, TIME-TAG, PSA	G130M 1222 A	BUFFER-TIME=48 4; FP-POS=3			584 Secs (584 Secs) [==>]	[1]																																																																																																
	Comments: Note: ETC simulation (for G130M-1291, so as to include Ly-alpha) is for an "extreme" FUV spectrum, scaled to V=7.2 mag, and thus will over-predict count rates for most of the targets (see Observation Description).																																																																																																									
	3	(COS.sp.100 5139)	(13) HD185239	COS/FUV, TIME-TAG, PSA	G130M 1222 A	BUFFER-TIME=48 4; FP-POS=4			584 Secs (584 Secs) [==>]	[1]																																																																																																
Comments: Note: ETC simulation (for G130M-1291, so as to include Ly-alpha) is for an "extreme" FUV spectrum, scaled to V=7.2 mag, and thus will over-predict count rates for most of the targets (see Observation Description).																																																																																																										
4	(COS.sp.100 5139)	(13) HD185239	COS/FUV, TIME-TAG, PSA	G130M 1291 A	BUFFER-TIME=48 4; FP-POS=3			584 Secs (584 Secs) [==>]	[1]																																																																																																	
Comments: Note: ETC simulation (for G130M-1291, so as to include Ly-alpha) is for an "extreme" FUV spectrum, scaled to V=7.2 mag, and thus will over-predict count rates for most of the targets (see Observation Description).																																																																																																										
5	(COS.sp.100 5139)	(13) HD185239	COS/FUV, TIME-TAG, PSA	G130M 1291 A	BUFFER-TIME=48 4; FP-POS=4			584 Secs (584 Secs) [==>]	[1]																																																																																																	
Comments: Note: ETC simulation (for G130M-1291, so as to include Ly-alpha) is for an "extreme" FUV spectrum, scaled to V=7.2 mag, and thus will over-predict count rates for most of the targets (see Observation Description).																																																																																																										

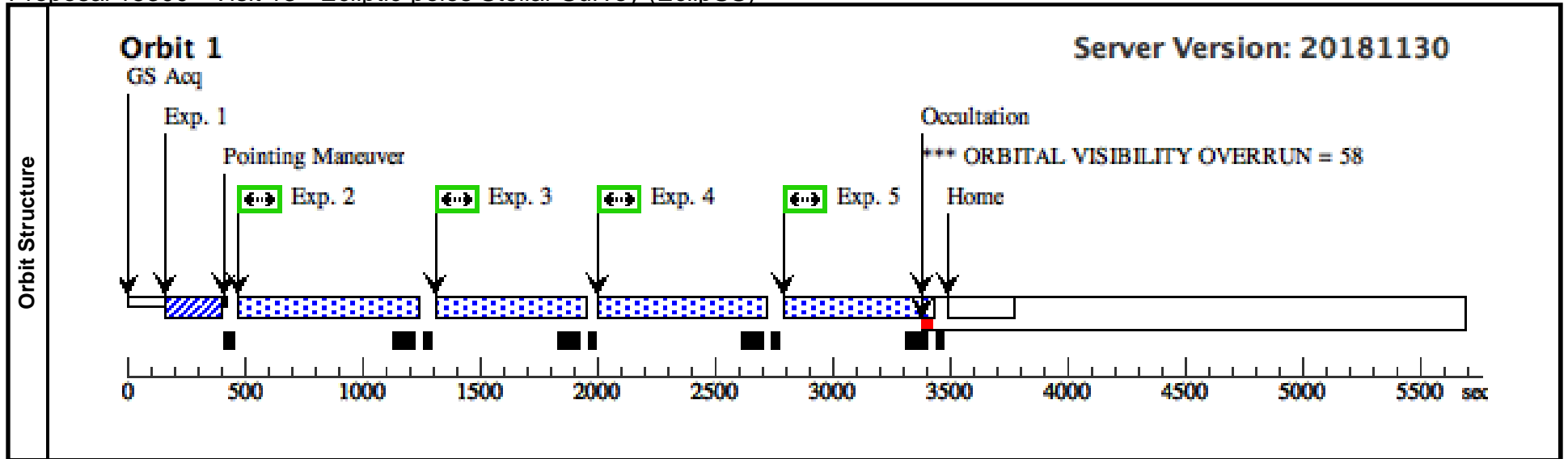

Proposal 15300 - Visit 14 - Ecliptic-poles Stellar Survey (EclipSS)

Thu Dec 13 22:02:07 GMT 2018

Visit	Proposal 15300, Visit 14, completed Diagnostic Status: Warning Scientific Instruments: COS/FUV, COS/NUV Special Requirements: (none)																																																																																																													
	(Visit 14) Warning (Form): For the best data quality, it is strongly recommended that the maximum number of allowed FP-POS positions is used when observing at a given COS CENWAVE setting. See full description for details. (Visit 14) Warning (Orbit Planner): ORBITAL VISIBILITY OVERRUN																																																																																																													
Fixed Targets	<table border="1"> <thead> <tr> <th>#</th> <th>Name</th> <th>Target Coordinates</th> <th>Targ. Coord. Corrections</th> <th>Fluxes</th> <th>Miscellaneous</th> </tr> </thead> <tbody> <tr> <td>(14)</td> <td>HD168093</td> <td>RA: 18 15 20.0053 (273.8333554d) Dec: +50 58 16.54 (50.97126d) Equinox: J2000</td> <td>Proper Motion RA: 15.03 mas/yr Proper Motion Dec: -36.72 mas/yr Parallax: 0.01792" Epoch of Position: 2000 Radial Velocity: 0.0 km/sec</td> <td>V=7.66+/-0.1 sptyp= F8V; (B-V)= 0.53 mag; dist= 54 pc</td> <td>Reference Frame: ICRS</td> </tr> </tbody> </table>						#	Name	Target Coordinates	Targ. Coord. Corrections	Fluxes	Miscellaneous	(14)	HD168093	RA: 18 15 20.0053 (273.8333554d) Dec: +50 58 16.54 (50.97126d) Equinox: J2000	Proper Motion RA: 15.03 mas/yr Proper Motion Dec: -36.72 mas/yr Parallax: 0.01792" Epoch of Position: 2000 Radial Velocity: 0.0 km/sec	V=7.66+/-0.1 sptyp= F8V; (B-V)= 0.53 mag; dist= 54 pc	Reference Frame: ICRS																																																																																												
	#	Name	Target Coordinates	Targ. Coord. Corrections	Fluxes	Miscellaneous																																																																																																								
(14)	HD168093	RA: 18 15 20.0053 (273.8333554d) Dec: +50 58 16.54 (50.97126d) Equinox: J2000	Proper Motion RA: 15.03 mas/yr Proper Motion Dec: -36.72 mas/yr Parallax: 0.01792" Epoch of Position: 2000 Radial Velocity: 0.0 km/sec	V=7.66+/-0.1 sptyp= F8V; (B-V)= 0.53 mag; dist= 54 pc	Reference Frame: ICRS																																																																																																									
Comments: Category=STAR Description=[F3-F9] Extended=NO																																																																																																														
Exposures	<table border="1"> <thead> <tr> <th>#</th> <th>Label (ETC Run)</th> <th>Target</th> <th>Config,Mode,Aperture</th> <th>Spectral Els.</th> <th>Opt. Params.</th> <th>Special Reqs.</th> <th>Groups</th> <th>Exp. Time (Total)/[Actual Dur.]</th> <th>Orbit</th> </tr> </thead> <tbody> <tr> <td>1</td> <td>(COS.ta.100 4278)</td> <td>(14) HD168093</td> <td>COS/NUV, ACQ/IMAGE, BOA</td> <td>MIRRORB</td> <td></td> <td></td> <td></td> <td>48 Secs (48 Secs) [==>]</td> <td>[1]</td> </tr> <tr> <td>2</td> <td>(COS.sp.100 5139)</td> <td>(14) HD168093</td> <td>COS/FUV, TIME-TAG, PSA</td> <td>G130M 1222 A</td> <td>BUFFER-TIME=44 2; FP-POS=3</td> <td></td> <td></td> <td>542 Secs (542 Secs) [==>]</td> <td>[1]</td> </tr> <tr> <td colspan="10"> Comments: Note: ETC simulation (for G130M-1291, so as to include Ly-alpha) is for an "extreme" FUV spectrum, scaled to V=7.2 mag, and thus will over-predict count rates for most of the targets (see Observation Description). </td> </tr> <tr> <td>3</td> <td>(COS.sp.100 5139)</td> <td>(14) HD168093</td> <td>COS/FUV, TIME-TAG, PSA</td> <td>G130M 1222 A</td> <td>BUFFER-TIME=44 2; FP-POS=4</td> <td></td> <td></td> <td>542 Secs (542 Secs) [==>]</td> <td>[1]</td> </tr> <tr> <td colspan="10"> Comments: Note: ETC simulation (for G130M-1291, so as to include Ly-alpha) is for an "extreme" FUV spectrum, scaled to V=7.2 mag, and thus will over-predict count rates for most of the targets (see Observation Description). </td> </tr> <tr> <td>4</td> <td>(COS.sp.100 5139)</td> <td>(14) HD168093</td> <td>COS/FUV, TIME-TAG, PSA</td> <td>G130M 1291 A</td> <td>BUFFER-TIME=44 2; FP-POS=3</td> <td></td> <td></td> <td>542 Secs (542 Secs) [==>]</td> <td>[1]</td> </tr> <tr> <td colspan="10"> Comments: Note: ETC simulation (for G130M-1291, so as to include Ly-alpha) is for an "extreme" FUV spectrum, scaled to V=7.2 mag, and thus will over-predict count rates for most of the targets (see Observation Description). </td> </tr> <tr> <td>5</td> <td>(COS.sp.100 5139)</td> <td>(14) HD168093</td> <td>COS/FUV, TIME-TAG, PSA</td> <td>G130M 1291 A</td> <td>BUFFER-TIME=44 2; FP-POS=4</td> <td></td> <td></td> <td>542 Secs (542 Secs) [==>]</td> <td>[1]</td> </tr> <tr> <td colspan="10"> Comments: Note: ETC simulation (for G130M-1291, so as to include Ly-alpha) is for an "extreme" FUV spectrum, scaled to V=7.2 mag, and thus will over-predict count rates for most of the targets (see Observation Description). </td> </tr> </tbody> </table>										#	Label (ETC Run)	Target	Config,Mode,Aperture	Spectral Els.	Opt. Params.	Special Reqs.	Groups	Exp. Time (Total)/[Actual Dur.]	Orbit	1	(COS.ta.100 4278)	(14) HD168093	COS/NUV, ACQ/IMAGE, BOA	MIRRORB				48 Secs (48 Secs) [==>]	[1]	2	(COS.sp.100 5139)	(14) HD168093	COS/FUV, TIME-TAG, PSA	G130M 1222 A	BUFFER-TIME=44 2; FP-POS=3			542 Secs (542 Secs) [==>]	[1]	Comments: Note: ETC simulation (for G130M-1291, so as to include Ly-alpha) is for an "extreme" FUV spectrum, scaled to V=7.2 mag, and thus will over-predict count rates for most of the targets (see Observation Description).										3	(COS.sp.100 5139)	(14) HD168093	COS/FUV, TIME-TAG, PSA	G130M 1222 A	BUFFER-TIME=44 2; FP-POS=4			542 Secs (542 Secs) [==>]	[1]	Comments: Note: ETC simulation (for G130M-1291, so as to include Ly-alpha) is for an "extreme" FUV spectrum, scaled to V=7.2 mag, and thus will over-predict count rates for most of the targets (see Observation Description).										4	(COS.sp.100 5139)	(14) HD168093	COS/FUV, TIME-TAG, PSA	G130M 1291 A	BUFFER-TIME=44 2; FP-POS=3			542 Secs (542 Secs) [==>]	[1]	Comments: Note: ETC simulation (for G130M-1291, so as to include Ly-alpha) is for an "extreme" FUV spectrum, scaled to V=7.2 mag, and thus will over-predict count rates for most of the targets (see Observation Description).										5	(COS.sp.100 5139)	(14) HD168093	COS/FUV, TIME-TAG, PSA	G130M 1291 A	BUFFER-TIME=44 2; FP-POS=4			542 Secs (542 Secs) [==>]	[1]	Comments: Note: ETC simulation (for G130M-1291, so as to include Ly-alpha) is for an "extreme" FUV spectrum, scaled to V=7.2 mag, and thus will over-predict count rates for most of the targets (see Observation Description).									
	#	Label (ETC Run)	Target	Config,Mode,Aperture	Spectral Els.	Opt. Params.	Special Reqs.	Groups	Exp. Time (Total)/[Actual Dur.]	Orbit																																																																																																				
	1	(COS.ta.100 4278)	(14) HD168093	COS/NUV, ACQ/IMAGE, BOA	MIRRORB				48 Secs (48 Secs) [==>]	[1]																																																																																																				
	2	(COS.sp.100 5139)	(14) HD168093	COS/FUV, TIME-TAG, PSA	G130M 1222 A	BUFFER-TIME=44 2; FP-POS=3			542 Secs (542 Secs) [==>]	[1]																																																																																																				
	Comments: Note: ETC simulation (for G130M-1291, so as to include Ly-alpha) is for an "extreme" FUV spectrum, scaled to V=7.2 mag, and thus will over-predict count rates for most of the targets (see Observation Description).																																																																																																													
	3	(COS.sp.100 5139)	(14) HD168093	COS/FUV, TIME-TAG, PSA	G130M 1222 A	BUFFER-TIME=44 2; FP-POS=4			542 Secs (542 Secs) [==>]	[1]																																																																																																				
Comments: Note: ETC simulation (for G130M-1291, so as to include Ly-alpha) is for an "extreme" FUV spectrum, scaled to V=7.2 mag, and thus will over-predict count rates for most of the targets (see Observation Description).																																																																																																														
4	(COS.sp.100 5139)	(14) HD168093	COS/FUV, TIME-TAG, PSA	G130M 1291 A	BUFFER-TIME=44 2; FP-POS=3			542 Secs (542 Secs) [==>]	[1]																																																																																																					
Comments: Note: ETC simulation (for G130M-1291, so as to include Ly-alpha) is for an "extreme" FUV spectrum, scaled to V=7.2 mag, and thus will over-predict count rates for most of the targets (see Observation Description).																																																																																																														
5	(COS.sp.100 5139)	(14) HD168093	COS/FUV, TIME-TAG, PSA	G130M 1291 A	BUFFER-TIME=44 2; FP-POS=4			542 Secs (542 Secs) [==>]	[1]																																																																																																					
Comments: Note: ETC simulation (for G130M-1291, so as to include Ly-alpha) is for an "extreme" FUV spectrum, scaled to V=7.2 mag, and thus will over-predict count rates for most of the targets (see Observation Description).																																																																																																														

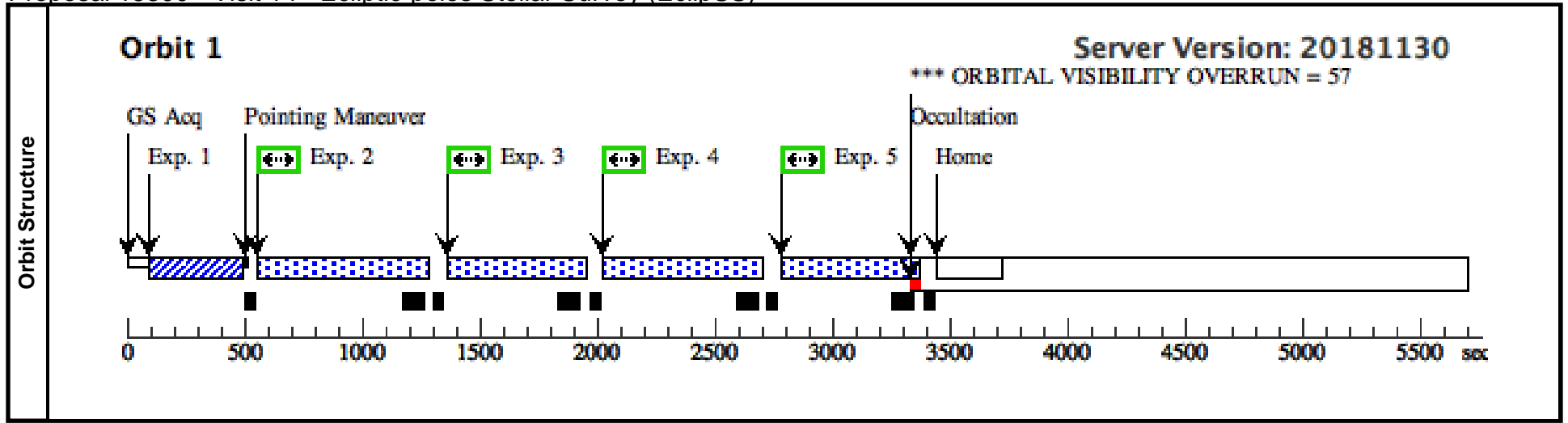

Proposal 15300 - Visit 15 - Ecliptic-poles Stellar Survey (EclipSS)

Thu Dec 13 22:02:07 GMT 2018

Visit	Proposal 15300, Visit 15, scheduling Diagnostic Status: Warning Scientific Instruments: COS/FUV, COS/NUV Special Requirements: (none)										
	(Visit 15) Warning (Form): For the best data quality, it is strongly recommended that the maximum number of allowed FP-POS positions is used when observing at a given COS CENWAVE setting. See full description for details. (Visit 15) Warning (Orbit Planner): ORBITAL VISIBILITY OVERRUN										
Fixed Targets	#	Name	Target Coordinates	Targ. Coord. Corrections	Fluxes	Miscellaneous					
	(15)	HD20052	RA: 03 10 8.7345 (47.5363938d) Dec: -62 21 27.49 (-62.35764d) Equinox: J2000	Proper Motion RA: -54.12 mas/yr Proper Motion Dec: -113.02 mas/yr Parallax: 0.01248" Epoch of Position: 2000 Radial Velocity: 0.0 km/sec	V=8.34+/-0.1 sptyp= F8V; (B-V)= 0.54 mag; dist= 79 pc	Reference Frame: ICRS					
Comments: Category=STAR Description=[F3-F9] Extended=NO											
Exposures	#	Label (ETC Run)	Target	Config,Mode,Aperture	Spectral Els.	Opt. Params.	Special Reqs.	Groups	Exp. Time (Total)/[Actual Dur.]	Orbit	
	1	(COS.ta.100 4279)	(15) HD20052	COS/NUV, ACQ/IMAGE, BOA	MIRRORA				5 Secs (5 Secs) [==>]	[1]	
	2	(COS.sp.100 5139)	(15) HD20052	COS/FUV, TIME-TAG, PSA	G130M 1222 A	0; FP-POS=3			590 Secs (590 Secs) [==>]	[1]	
	Comments: Note: ETC simulation (for G130M-1291, so as to include Ly-alpha) is for an "extreme" FUV spectrum, scaled to V=7.2 mag, and thus will over-predict count rates for most of the targets (see Observation Description).										
	3	(COS.sp.100 5139)	(15) HD20052	COS/FUV, TIME-TAG, PSA	G130M 1222 A	0; FP-POS=4			590 Secs (590 Secs) [==>]	[1]	
	Comments: Note: ETC simulation (for G130M-1291, so as to include Ly-alpha) is for an "extreme" FUV spectrum, scaled to V=7.2 mag, and thus will over-predict count rates for most of the targets (see Observation Description).										
4	(COS.sp.100 5139)	(15) HD20052	COS/FUV, TIME-TAG, PSA	G130M 1291 A	0; FP-POS=3			590 Secs (590 Secs) [==>]	[1]		
Comments: Note: ETC simulation (for G130M-1291, so as to include Ly-alpha) is for an "extreme" FUV spectrum, scaled to V=7.2 mag, and thus will over-predict count rates for most of the targets (see Observation Description).											
5	(COS.sp.100 5139)	(15) HD20052	COS/FUV, TIME-TAG, PSA	G130M 1291 A	0; FP-POS=4			590 Secs (590 Secs) [==>]	[1]		
Comments: Note: ETC simulation (for G130M-1291, so as to include Ly-alpha) is for an "extreme" FUV spectrum, scaled to V=7.2 mag, and thus will over-predict count rates for most of the targets (see Observation Description).											

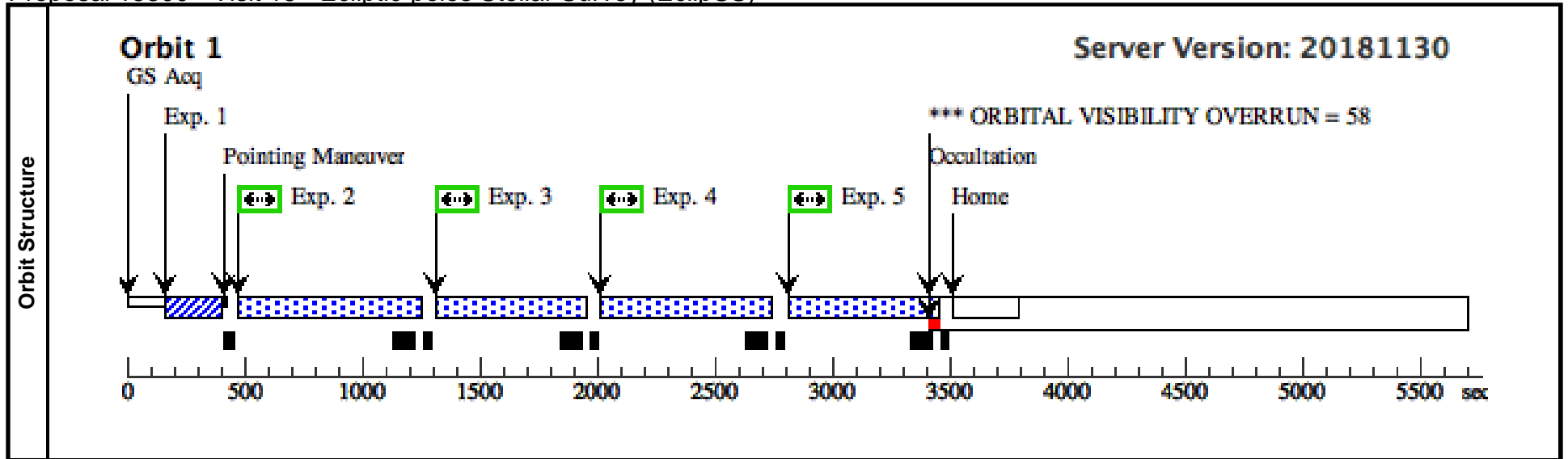

Proposal 15300 - Visit 16 - Ecliptic-poles Stellar Survey (EclipSS)

Thu Dec 13 22:02:07 GMT 2018

Visit	Proposal 15300, Visit 16, completed Diagnostic Status: Warning Scientific Instruments: COS/FUV, COS/NUV Special Requirements: (none)																																																																																																									
	(Visit 16) Warning (Form): For the best data quality, it is strongly recommended that the maximum number of allowed FP-POS positions is used when observing at a given COS CENWAVE setting. See full description for details. (Visit 16) Warning (Orbit Planner): ORBITAL VISIBILITY OVERRUN																																																																																																									
Diagnosics																																																																																																										
Fixed Targets	<table border="1"> <thead> <tr> <th>#</th> <th>Name</th> <th>Target Coordinates</th> <th>Targ. Coord. Corrections</th> <th>Fluxes</th> <th>Miscellaneous</th> </tr> </thead> <tbody> <tr> <td>(16)</td> <td>HD180712</td> <td>RA: 19 14 1.4621 (288.5060921d) Dec: +59 33 6.57 (59.55182d) Equinox: J2000</td> <td>Proper Motion RA: 45.68 mas/yr Proper Motion Dec: 112.12 mas/yr Parallax: 0.02244" Epoch of Position: 2000 Radial Velocity: 0.0 km/sec</td> <td>V=7.99+/-0.1 sptyp= F8V; (B-V)= 0.58 mag; dist= 45 pc</td> <td>Reference Frame: ICRS</td> </tr> </tbody> </table>	#	Name	Target Coordinates	Targ. Coord. Corrections	Fluxes	Miscellaneous	(16)	HD180712	RA: 19 14 1.4621 (288.5060921d) Dec: +59 33 6.57 (59.55182d) Equinox: J2000	Proper Motion RA: 45.68 mas/yr Proper Motion Dec: 112.12 mas/yr Parallax: 0.02244" Epoch of Position: 2000 Radial Velocity: 0.0 km/sec	V=7.99+/-0.1 sptyp= F8V; (B-V)= 0.58 mag; dist= 45 pc	Reference Frame: ICRS	Comments: Category=STAR Description=[F3-F9] Extended=NO																																																																																												
	#	Name	Target Coordinates	Targ. Coord. Corrections	Fluxes	Miscellaneous																																																																																																				
(16)	HD180712	RA: 19 14 1.4621 (288.5060921d) Dec: +59 33 6.57 (59.55182d) Equinox: J2000	Proper Motion RA: 45.68 mas/yr Proper Motion Dec: 112.12 mas/yr Parallax: 0.02244" Epoch of Position: 2000 Radial Velocity: 0.0 km/sec	V=7.99+/-0.1 sptyp= F8V; (B-V)= 0.58 mag; dist= 45 pc	Reference Frame: ICRS																																																																																																					
Exposures	<table border="1"> <thead> <tr> <th>#</th> <th>Label (ETC Run)</th> <th>Target</th> <th>Config,Mode,Aperture</th> <th>Spectral Els.</th> <th>Opt. Params.</th> <th>Special Reqs.</th> <th>Groups</th> <th>Exp. Time (Total)/[Actual Dur.]</th> <th>Orbit</th> </tr> </thead> <tbody> <tr> <td>1</td> <td>(COS.ta.100 4280)</td> <td>(16) HD180712</td> <td>COS/NUV, ACQ/IMAGE, BOA</td> <td>MIRRORA</td> <td></td> <td></td> <td></td> <td>4 Secs (4 Secs) [==>]</td> <td>[1]</td> </tr> <tr> <td>2</td> <td>(COS.sp.100 5139)</td> <td>(16) HD180712</td> <td>COS/FUV, TIME-TAG, PSA</td> <td>G130M 1222 A</td> <td>BUFFER-TIME=48 5; FP-POS=3</td> <td></td> <td></td> <td>585 Secs (585 Secs) [==>]</td> <td>[1]</td> </tr> <tr> <td colspan="10"> Comments: Note: ETC simulation (for G130M-1291, so as to include Ly-alpha) is for an "extreme" FUV spectrum, scaled to V=7.2 mag, and thus will over-predict count rates for most of the targets (see Observation Description). </td> </tr> <tr> <td>3</td> <td>(COS.sp.100 5139)</td> <td>(16) HD180712</td> <td>COS/FUV, TIME-TAG, PSA</td> <td>G130M 1222 A</td> <td>BUFFER-TIME=48 5; FP-POS=4</td> <td></td> <td></td> <td>585 Secs (585 Secs) [==>]</td> <td>[1]</td> </tr> <tr> <td colspan="10"> Comments: Note: ETC simulation (for G130M-1291, so as to include Ly-alpha) is for an "extreme" FUV spectrum, scaled to V=7.2 mag, and thus will over-predict count rates for most of the targets (see Observation Description). </td> </tr> <tr> <td>4</td> <td>(COS.sp.100 5139)</td> <td>(16) HD180712</td> <td>COS/FUV, TIME-TAG, PSA</td> <td>G130M 1291 A</td> <td>BUFFER-TIME=48 5; FP-POS=3</td> <td></td> <td></td> <td>585 Secs (585 Secs) [==>]</td> <td>[1]</td> </tr> <tr> <td colspan="10"> Comments: Note: ETC simulation (for G130M-1291, so as to include Ly-alpha) is for an "extreme" FUV spectrum, scaled to V=7.2 mag, and thus will over-predict count rates for most of the targets (see Observation Description). </td> </tr> <tr> <td>5</td> <td>(COS.sp.100 5139)</td> <td>(16) HD180712</td> <td>COS/FUV, TIME-TAG, PSA</td> <td>G130M 1291 A</td> <td>BUFFER-TIME=48 5; FP-POS=4</td> <td></td> <td></td> <td>585 Secs (585 Secs) [==>]</td> <td>[1]</td> </tr> <tr> <td colspan="10"> Comments: Note: ETC simulation (for G130M-1291, so as to include Ly-alpha) is for an "extreme" FUV spectrum, scaled to V=7.2 mag, and thus will over-predict count rates for most of the targets (see Observation Description). </td> </tr> </tbody> </table>	#	Label (ETC Run)	Target	Config,Mode,Aperture	Spectral Els.	Opt. Params.	Special Reqs.	Groups	Exp. Time (Total)/[Actual Dur.]	Orbit	1	(COS.ta.100 4280)	(16) HD180712	COS/NUV, ACQ/IMAGE, BOA	MIRRORA				4 Secs (4 Secs) [==>]	[1]	2	(COS.sp.100 5139)	(16) HD180712	COS/FUV, TIME-TAG, PSA	G130M 1222 A	BUFFER-TIME=48 5; FP-POS=3			585 Secs (585 Secs) [==>]	[1]	Comments: Note: ETC simulation (for G130M-1291, so as to include Ly-alpha) is for an "extreme" FUV spectrum, scaled to V=7.2 mag, and thus will over-predict count rates for most of the targets (see Observation Description).										3	(COS.sp.100 5139)	(16) HD180712	COS/FUV, TIME-TAG, PSA	G130M 1222 A	BUFFER-TIME=48 5; FP-POS=4			585 Secs (585 Secs) [==>]	[1]	Comments: Note: ETC simulation (for G130M-1291, so as to include Ly-alpha) is for an "extreme" FUV spectrum, scaled to V=7.2 mag, and thus will over-predict count rates for most of the targets (see Observation Description).										4	(COS.sp.100 5139)	(16) HD180712	COS/FUV, TIME-TAG, PSA	G130M 1291 A	BUFFER-TIME=48 5; FP-POS=3			585 Secs (585 Secs) [==>]	[1]	Comments: Note: ETC simulation (for G130M-1291, so as to include Ly-alpha) is for an "extreme" FUV spectrum, scaled to V=7.2 mag, and thus will over-predict count rates for most of the targets (see Observation Description).										5	(COS.sp.100 5139)	(16) HD180712	COS/FUV, TIME-TAG, PSA	G130M 1291 A	BUFFER-TIME=48 5; FP-POS=4			585 Secs (585 Secs) [==>]	[1]	Comments: Note: ETC simulation (for G130M-1291, so as to include Ly-alpha) is for an "extreme" FUV spectrum, scaled to V=7.2 mag, and thus will over-predict count rates for most of the targets (see Observation Description).														
	#	Label (ETC Run)	Target	Config,Mode,Aperture	Spectral Els.	Opt. Params.	Special Reqs.	Groups	Exp. Time (Total)/[Actual Dur.]	Orbit																																																																																																
	1	(COS.ta.100 4280)	(16) HD180712	COS/NUV, ACQ/IMAGE, BOA	MIRRORA				4 Secs (4 Secs) [==>]	[1]																																																																																																
	2	(COS.sp.100 5139)	(16) HD180712	COS/FUV, TIME-TAG, PSA	G130M 1222 A	BUFFER-TIME=48 5; FP-POS=3			585 Secs (585 Secs) [==>]	[1]																																																																																																
	Comments: Note: ETC simulation (for G130M-1291, so as to include Ly-alpha) is for an "extreme" FUV spectrum, scaled to V=7.2 mag, and thus will over-predict count rates for most of the targets (see Observation Description).																																																																																																									
	3	(COS.sp.100 5139)	(16) HD180712	COS/FUV, TIME-TAG, PSA	G130M 1222 A	BUFFER-TIME=48 5; FP-POS=4			585 Secs (585 Secs) [==>]	[1]																																																																																																
Comments: Note: ETC simulation (for G130M-1291, so as to include Ly-alpha) is for an "extreme" FUV spectrum, scaled to V=7.2 mag, and thus will over-predict count rates for most of the targets (see Observation Description).																																																																																																										
4	(COS.sp.100 5139)	(16) HD180712	COS/FUV, TIME-TAG, PSA	G130M 1291 A	BUFFER-TIME=48 5; FP-POS=3			585 Secs (585 Secs) [==>]	[1]																																																																																																	
Comments: Note: ETC simulation (for G130M-1291, so as to include Ly-alpha) is for an "extreme" FUV spectrum, scaled to V=7.2 mag, and thus will over-predict count rates for most of the targets (see Observation Description).																																																																																																										
5	(COS.sp.100 5139)	(16) HD180712	COS/FUV, TIME-TAG, PSA	G130M 1291 A	BUFFER-TIME=48 5; FP-POS=4			585 Secs (585 Secs) [==>]	[1]																																																																																																	
Comments: Note: ETC simulation (for G130M-1291, so as to include Ly-alpha) is for an "extreme" FUV spectrum, scaled to V=7.2 mag, and thus will over-predict count rates for most of the targets (see Observation Description).																																																																																																										

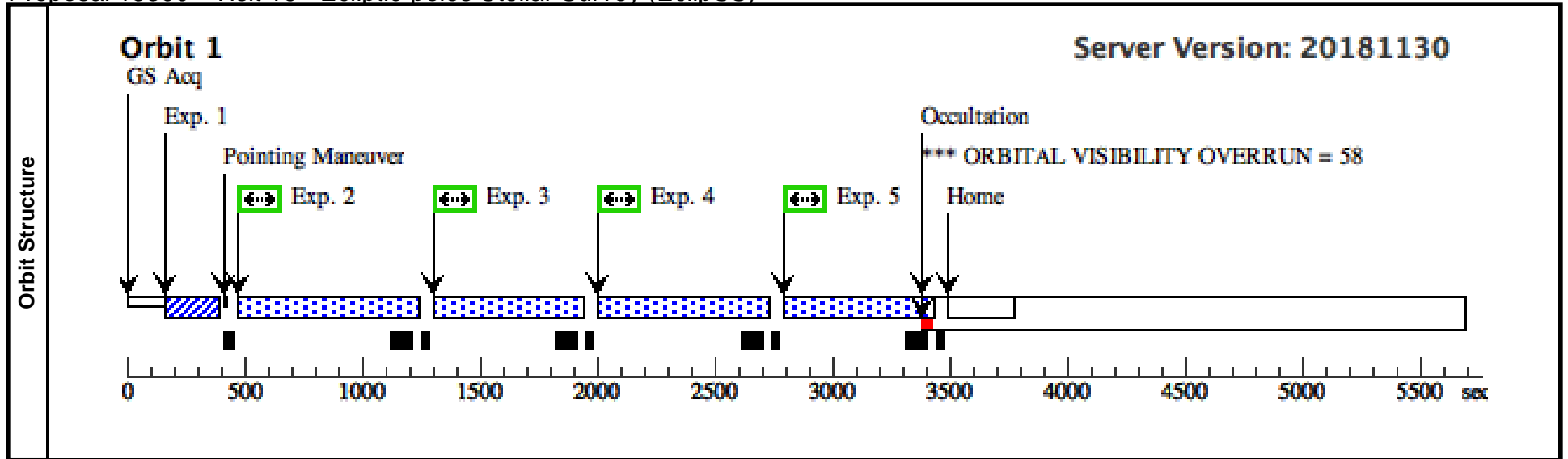

Proposal 15300 - Visit 17 - Ecliptic-poles Stellar Survey (EclipSS)

Thu Dec 13 22:02:07 GMT 2018

Visit	Proposal 15300, Visit 17, completed Diagnostic Status: Warning Scientific Instruments: COS/FUV, COS/NUV Special Requirements: (none)																																																																																																									
	(Visit 17) Warning (Form): For the best data quality, it is strongly recommended that the maximum number of allowed FP-POS positions is used when observing at a given COS CENWAVE setting. See full description for details. (Visit 17) Warning (Orbit Planner): ORBITAL VISIBILITY OVERRUN																																																																																																									
Diagnosics																																																																																																										
Fixed Targets	<table border="1"> <thead> <tr> <th>#</th> <th>Name</th> <th>Target Coordinates</th> <th>Targ. Coord. Corrections</th> <th>Fluxes</th> <th>Miscellaneous</th> </tr> </thead> <tbody> <tr> <td>(17)</td> <td>HD159329</td> <td>RA: 17 29 44.4513 (262.4352138d) Dec: +63 51 9.56 (63.85266d) Equinox: J2000</td> <td>Proper Motion RA: 2.53 mas/yr Proper Motion Dec: -181.58 mas/yr Parallax: 0.02212" Epoch of Position: 2000 Radial Velocity: 0.0 km/sec</td> <td>V=7.67+/-0.1 sptyp= F9V; (B-V)= 0.52 mag; dist= 46 pc</td> <td>Reference Frame: ICRS</td> </tr> </tbody> </table>	#	Name	Target Coordinates	Targ. Coord. Corrections	Fluxes	Miscellaneous	(17)	HD159329	RA: 17 29 44.4513 (262.4352138d) Dec: +63 51 9.56 (63.85266d) Equinox: J2000	Proper Motion RA: 2.53 mas/yr Proper Motion Dec: -181.58 mas/yr Parallax: 0.02212" Epoch of Position: 2000 Radial Velocity: 0.0 km/sec	V=7.67+/-0.1 sptyp= F9V; (B-V)= 0.52 mag; dist= 46 pc	Reference Frame: ICRS	Comments: Category=STAR Description=[F3-F9] Extended=NO																																																																																												
	#	Name	Target Coordinates	Targ. Coord. Corrections	Fluxes	Miscellaneous																																																																																																				
(17)	HD159329	RA: 17 29 44.4513 (262.4352138d) Dec: +63 51 9.56 (63.85266d) Equinox: J2000	Proper Motion RA: 2.53 mas/yr Proper Motion Dec: -181.58 mas/yr Parallax: 0.02212" Epoch of Position: 2000 Radial Velocity: 0.0 km/sec	V=7.67+/-0.1 sptyp= F9V; (B-V)= 0.52 mag; dist= 46 pc	Reference Frame: ICRS																																																																																																					
Exposures	<table border="1"> <thead> <tr> <th>#</th> <th>Label (ETC Run)</th> <th>Target</th> <th>Config,Mode,Aperture</th> <th>Spectral Els.</th> <th>Opt. Params.</th> <th>Special Reqs.</th> <th>Groups</th> <th>Exp. Time (Total)/[Actual Dur.]</th> <th>Orbit</th> </tr> </thead> <tbody> <tr> <td>1</td> <td>(COS.ta.100 4281)</td> <td>(17) HD159329</td> <td>COS/NUV, ACQ/IMAGE, BOA</td> <td>MIRRORB</td> <td></td> <td></td> <td></td> <td>47 Secs (47 Secs) [==>]</td> <td>[1]</td> </tr> <tr> <td>2</td> <td>(COS.sp.100 5139)</td> <td>(17) HD159329</td> <td>COS/FUV, TIME-TAG, PSA</td> <td>G130M 1222 A</td> <td>BUFFER-TIME=46 9; FP-POS=3</td> <td></td> <td></td> <td>569 Secs (569 Secs) [==>]</td> <td>[1]</td> </tr> <tr> <td colspan="10"> Comments: Note: ETC simulation (for G130M-1291, so as to include Ly-alpha) is for an "extreme" FUV spectrum, scaled to V=7.2 mag, and thus will over-predict count rates for most of the targets (see Observation Description). </td> </tr> <tr> <td>3</td> <td>(COS.sp.100 5139)</td> <td>(17) HD159329</td> <td>COS/FUV, TIME-TAG, PSA</td> <td>G130M 1222 A</td> <td>BUFFER-TIME=46 9; FP-POS=4</td> <td></td> <td></td> <td>569 Secs (569 Secs) [==>]</td> <td>[1]</td> </tr> <tr> <td colspan="10"> Comments: Note: ETC simulation (for G130M-1291, so as to include Ly-alpha) is for an "extreme" FUV spectrum, scaled to V=7.2 mag, and thus will over-predict count rates for most of the targets (see Observation Description). </td> </tr> <tr> <td>4</td> <td>(COS.sp.100 5139)</td> <td>(17) HD159329</td> <td>COS/FUV, TIME-TAG, PSA</td> <td>G130M 1291 A</td> <td>BUFFER-TIME=46 9; FP-POS=3</td> <td></td> <td></td> <td>569 Secs (569 Secs) [==>]</td> <td>[1]</td> </tr> <tr> <td colspan="10"> Comments: Note: ETC simulation (for G130M-1291, so as to include Ly-alpha) is for an "extreme" FUV spectrum, scaled to V=7.2 mag, and thus will over-predict count rates for most of the targets (see Observation Description). </td> </tr> <tr> <td>5</td> <td>(COS.sp.100 5139)</td> <td>(17) HD159329</td> <td>COS/FUV, TIME-TAG, PSA</td> <td>G130M 1291 A</td> <td>BUFFER-TIME=46 9; FP-POS=4</td> <td></td> <td></td> <td>569 Secs (569 Secs) [==>]</td> <td>[1]</td> </tr> <tr> <td colspan="10"> Comments: Note: ETC simulation (for G130M-1291, so as to include Ly-alpha) is for an "extreme" FUV spectrum, scaled to V=7.2 mag, and thus will over-predict count rates for most of the targets (see Observation Description). </td> </tr> </tbody> </table>	#	Label (ETC Run)	Target	Config,Mode,Aperture	Spectral Els.	Opt. Params.	Special Reqs.	Groups	Exp. Time (Total)/[Actual Dur.]	Orbit	1	(COS.ta.100 4281)	(17) HD159329	COS/NUV, ACQ/IMAGE, BOA	MIRRORB				47 Secs (47 Secs) [==>]	[1]	2	(COS.sp.100 5139)	(17) HD159329	COS/FUV, TIME-TAG, PSA	G130M 1222 A	BUFFER-TIME=46 9; FP-POS=3			569 Secs (569 Secs) [==>]	[1]	Comments: Note: ETC simulation (for G130M-1291, so as to include Ly-alpha) is for an "extreme" FUV spectrum, scaled to V=7.2 mag, and thus will over-predict count rates for most of the targets (see Observation Description).										3	(COS.sp.100 5139)	(17) HD159329	COS/FUV, TIME-TAG, PSA	G130M 1222 A	BUFFER-TIME=46 9; FP-POS=4			569 Secs (569 Secs) [==>]	[1]	Comments: Note: ETC simulation (for G130M-1291, so as to include Ly-alpha) is for an "extreme" FUV spectrum, scaled to V=7.2 mag, and thus will over-predict count rates for most of the targets (see Observation Description).										4	(COS.sp.100 5139)	(17) HD159329	COS/FUV, TIME-TAG, PSA	G130M 1291 A	BUFFER-TIME=46 9; FP-POS=3			569 Secs (569 Secs) [==>]	[1]	Comments: Note: ETC simulation (for G130M-1291, so as to include Ly-alpha) is for an "extreme" FUV spectrum, scaled to V=7.2 mag, and thus will over-predict count rates for most of the targets (see Observation Description).										5	(COS.sp.100 5139)	(17) HD159329	COS/FUV, TIME-TAG, PSA	G130M 1291 A	BUFFER-TIME=46 9; FP-POS=4			569 Secs (569 Secs) [==>]	[1]	Comments: Note: ETC simulation (for G130M-1291, so as to include Ly-alpha) is for an "extreme" FUV spectrum, scaled to V=7.2 mag, and thus will over-predict count rates for most of the targets (see Observation Description).														
	#	Label (ETC Run)	Target	Config,Mode,Aperture	Spectral Els.	Opt. Params.	Special Reqs.	Groups	Exp. Time (Total)/[Actual Dur.]	Orbit																																																																																																
	1	(COS.ta.100 4281)	(17) HD159329	COS/NUV, ACQ/IMAGE, BOA	MIRRORB				47 Secs (47 Secs) [==>]	[1]																																																																																																
	2	(COS.sp.100 5139)	(17) HD159329	COS/FUV, TIME-TAG, PSA	G130M 1222 A	BUFFER-TIME=46 9; FP-POS=3			569 Secs (569 Secs) [==>]	[1]																																																																																																
	Comments: Note: ETC simulation (for G130M-1291, so as to include Ly-alpha) is for an "extreme" FUV spectrum, scaled to V=7.2 mag, and thus will over-predict count rates for most of the targets (see Observation Description).																																																																																																									
	3	(COS.sp.100 5139)	(17) HD159329	COS/FUV, TIME-TAG, PSA	G130M 1222 A	BUFFER-TIME=46 9; FP-POS=4			569 Secs (569 Secs) [==>]	[1]																																																																																																
Comments: Note: ETC simulation (for G130M-1291, so as to include Ly-alpha) is for an "extreme" FUV spectrum, scaled to V=7.2 mag, and thus will over-predict count rates for most of the targets (see Observation Description).																																																																																																										
4	(COS.sp.100 5139)	(17) HD159329	COS/FUV, TIME-TAG, PSA	G130M 1291 A	BUFFER-TIME=46 9; FP-POS=3			569 Secs (569 Secs) [==>]	[1]																																																																																																	
Comments: Note: ETC simulation (for G130M-1291, so as to include Ly-alpha) is for an "extreme" FUV spectrum, scaled to V=7.2 mag, and thus will over-predict count rates for most of the targets (see Observation Description).																																																																																																										
5	(COS.sp.100 5139)	(17) HD159329	COS/FUV, TIME-TAG, PSA	G130M 1291 A	BUFFER-TIME=46 9; FP-POS=4			569 Secs (569 Secs) [==>]	[1]																																																																																																	
Comments: Note: ETC simulation (for G130M-1291, so as to include Ly-alpha) is for an "extreme" FUV spectrum, scaled to V=7.2 mag, and thus will over-predict count rates for most of the targets (see Observation Description).																																																																																																										

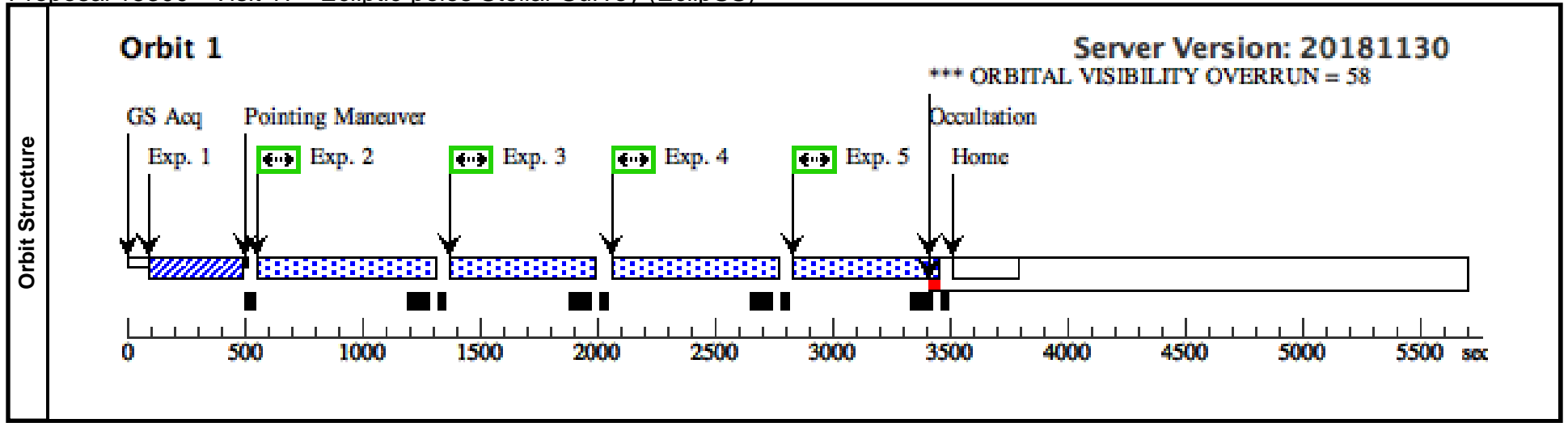

Proposal 15300 - Visit 18 - Ecliptic-poles Stellar Survey (EclipSS)

Thu Dec 13 22:02:07 GMT 2018

Visit	Proposal 15300, Visit 18, completed Diagnostic Status: Warning Scientific Instruments: COS/FUV, COS/NUV Special Requirements: (none)										
	(Visit 18) Warning (Form): For the best data quality, it is strongly recommended that the maximum number of allowed FP-POS positions is used when observing at a given COS CENWAVE setting. See full description for details. (Visit 18) Warning (Orbit Planner): ORBITAL VISIBILITY OVERRUN										
Diagnosics											
Fixed Targets	#	Name	Target Coordinates	Targ. Coord. Corrections		Fluxes	Miscellaneous				
	(18)	HD36767	RA: 05 25 19.0338 (81.3293075d) Dec: -75 41 32.65 (-75.69240d) Equinox: J2000	Proper Motion RA: -103.61 mas/yr Proper Motion Dec: -309.98 mas/yr Parallax: 0.02788" Epoch of Position: 2000 Radial Velocity: 0.0 km/sec	V=7.18+/-0.1 sptyp= F9V; (B-V)= 0.53 mag; dist= 36 pc		Reference Frame: ICRS				
Comments: Category=STAR Description=[F3-F9] Extended=NO											
Exposures	#	Label (ETC Run)	Target	Config,Mode,Aperture	Spectral Els.	Opt. Params.	Special Reqs.	Groups	Exp. Time (Total)/[Actual Dur.]		Orbit
	1	(COS.ta.100 4282)	(18) HD36767	COS/NUV, ACQ/IMAGE, BOA	MIRRORB				31 Secs (31 Secs) [==>]		[1]
2	(COS.sp.100 5139)	(18) HD36767	COS/FUV, TIME-TAG, PSA	G130M 1222 A	BUFFER-TIME=50 4; FP-POS=3			604 Secs (604 Secs) [==>]		[1]	
Comments: Note: ETC simulation (for G130M-1291, so as to include Ly-alpha) is for an "extreme" FUV spectrum, scaled to V=7.2 mag, and thus will over-predict count rates for most of the targets (see Observation Description).											
3	(COS.sp.100 5139)	(18) HD36767	COS/FUV, TIME-TAG, PSA	G130M 1222 A	BUFFER-TIME=50 4; FP-POS=4			604 Secs (604 Secs) [==>]		[1]	
Comments: Note: ETC simulation (for G130M-1291, so as to include Ly-alpha) is for an "extreme" FUV spectrum, scaled to V=7.2 mag, and thus will over-predict count rates for most of the targets (see Observation Description).											
4	(COS.sp.100 5139)	(18) HD36767	COS/FUV, TIME-TAG, PSA	G130M 1291 A	BUFFER-TIME=50 4; FP-POS=3			604 Secs (604 Secs) [==>]		[1]	
Comments: Note: ETC simulation (for G130M-1291, so as to include Ly-alpha) is for an "extreme" FUV spectrum, scaled to V=7.2 mag, and thus will over-predict count rates for most of the targets (see Observation Description).											
5	(COS.sp.100 5139)	(18) HD36767	COS/FUV, TIME-TAG, PSA	G130M 1291 A	BUFFER-TIME=50 4; FP-POS=4			604 Secs (604 Secs) [==>]		[1]	
Comments: Note: ETC simulation (for G130M-1291, so as to include Ly-alpha) is for an "extreme" FUV spectrum, scaled to V=7.2 mag, and thus will over-predict count rates for most of the targets (see Observation Description).											

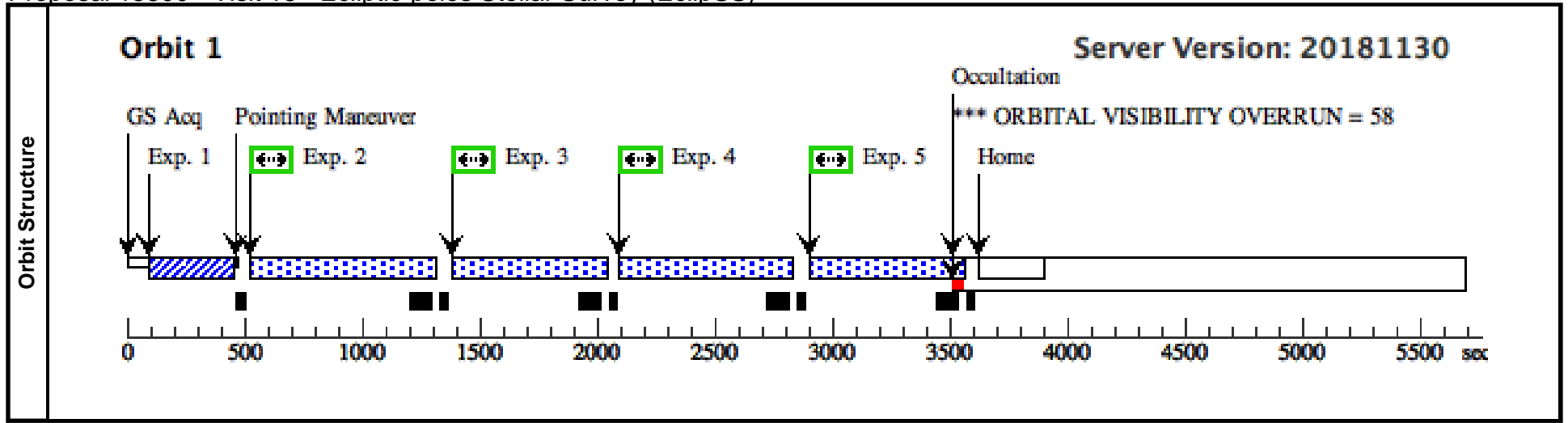

Proposal 15300 - Visit 19 - Ecliptic-poles Stellar Survey (EclipSS)

Thu Dec 13 22:02:07 GMT 2018

Visit	Proposal 15300, Visit 19, completed Diagnostic Status: Warning Scientific Instruments: COS/FUV, COS/NUV Special Requirements: (none)																																																																																																									
	(Visit 19) Warning (Form): For the best data quality, it is strongly recommended that the maximum number of allowed FP-POS positions is used when observing at a given COS CENWAVE setting. See full description for details. (Visit 19) Warning (Orbit Planner): ORBITAL VISIBILITY OVERRUN																																																																																																									
Diagnosics																																																																																																										
Fixed Targets	<table border="1"> <thead> <tr> <th>#</th> <th>Name</th> <th>Target Coordinates</th> <th>Targ. Coord. Corrections</th> <th>Fluxes</th> <th>Miscellaneous</th> </tr> </thead> <tbody> <tr> <td>(19)</td> <td>HD187876</td> <td>RA: 19 49 12.1764 (297.3007350d) Dec: +57 24 33.60 (57.40933d) Equinox: J2000</td> <td>Proper Motion RA: -6.03 mas/yr Proper Motion Dec: -60.57 mas/yr Parallax: 0.02131" Epoch of Position: 2000 Radial Velocity: 0.0 km/sec</td> <td>V=7.76+/-0.1 sptyp= G0V; (B-V)= 0.56 mag; dist= 47 pc</td> <td>Reference Frame: ICRS</td> </tr> </tbody> </table>	#	Name	Target Coordinates	Targ. Coord. Corrections	Fluxes	Miscellaneous	(19)	HD187876	RA: 19 49 12.1764 (297.3007350d) Dec: +57 24 33.60 (57.40933d) Equinox: J2000	Proper Motion RA: -6.03 mas/yr Proper Motion Dec: -60.57 mas/yr Parallax: 0.02131" Epoch of Position: 2000 Radial Velocity: 0.0 km/sec	V=7.76+/-0.1 sptyp= G0V; (B-V)= 0.56 mag; dist= 47 pc	Reference Frame: ICRS	Comments: Category=STAR Description=[G V-IV] Extended=NO																																																																																												
	#	Name	Target Coordinates	Targ. Coord. Corrections	Fluxes	Miscellaneous																																																																																																				
(19)	HD187876	RA: 19 49 12.1764 (297.3007350d) Dec: +57 24 33.60 (57.40933d) Equinox: J2000	Proper Motion RA: -6.03 mas/yr Proper Motion Dec: -60.57 mas/yr Parallax: 0.02131" Epoch of Position: 2000 Radial Velocity: 0.0 km/sec	V=7.76+/-0.1 sptyp= G0V; (B-V)= 0.56 mag; dist= 47 pc	Reference Frame: ICRS																																																																																																					
Exposures	<table border="1"> <thead> <tr> <th>#</th> <th>Label (ETC Run)</th> <th>Target</th> <th>Config,Mode,Aperture</th> <th>Spectral Els.</th> <th>Opt. Params.</th> <th>Special Reqs.</th> <th>Groups</th> <th>Exp. Time (Total)/[Actual Dur.]</th> <th>Orbit</th> </tr> </thead> <tbody> <tr> <td>1</td> <td>(COS.ta.100 4284)</td> <td>(19) HD187876</td> <td>COS/NUV, ACQ/IMAGE, BOA</td> <td>MIRRORA</td> <td></td> <td></td> <td></td> <td>4 Secs (4 Secs) [==>]</td> <td>[1]</td> </tr> <tr> <td>2</td> <td>(COS.sp.100 5139)</td> <td>(19) HD187876</td> <td>COS/FUV, TIME-TAG, PSA</td> <td>G130M 1222 A</td> <td>BUFFER-TIME=48 5; FP-POS=3</td> <td></td> <td></td> <td>585 Secs (585 Secs) [==>]</td> <td>[1]</td> </tr> <tr> <td colspan="10"> Comments: Note: ETC simulation (for G130M-1291, so as to include Ly-alpha) is for an "extreme" FUV spectrum, scaled to V=7.2 mag, and thus will over-predict count rates for most of the targets (see Observation Description). </td> </tr> <tr> <td>3</td> <td>(COS.sp.100 5139)</td> <td>(19) HD187876</td> <td>COS/FUV, TIME-TAG, PSA</td> <td>G130M 1222 A</td> <td>BUFFER-TIME=48 5; FP-POS=4</td> <td></td> <td></td> <td>585 Secs (585 Secs) [==>]</td> <td>[1]</td> </tr> <tr> <td colspan="10"> Comments: Note: ETC simulation (for G130M-1291, so as to include Ly-alpha) is for an "extreme" FUV spectrum, scaled to V=7.2 mag, and thus will over-predict count rates for most of the targets (see Observation Description). </td> </tr> <tr> <td>4</td> <td>(COS.sp.100 5139)</td> <td>(19) HD187876</td> <td>COS/FUV, TIME-TAG, PSA</td> <td>G130M 1291 A</td> <td>BUFFER-TIME=48 5; FP-POS=3</td> <td></td> <td></td> <td>585 Secs (585 Secs) [==>]</td> <td>[1]</td> </tr> <tr> <td colspan="10"> Comments: Note: ETC simulation (for G130M-1291, so as to include Ly-alpha) is for an "extreme" FUV spectrum, scaled to V=7.2 mag, and thus will over-predict count rates for most of the targets (see Observation Description). </td> </tr> <tr> <td>5</td> <td>(COS.sp.100 5139)</td> <td>(19) HD187876</td> <td>COS/FUV, TIME-TAG, PSA</td> <td>G130M 1291 A</td> <td>BUFFER-TIME=48 5; FP-POS=4</td> <td></td> <td></td> <td>585 Secs (585 Secs) [==>]</td> <td>[1]</td> </tr> <tr> <td colspan="10"> Comments: Note: ETC simulation (for G130M-1291, so as to include Ly-alpha) is for an "extreme" FUV spectrum, scaled to V=7.2 mag, and thus will over-predict count rates for most of the targets (see Observation Description). </td> </tr> </tbody> </table>	#	Label (ETC Run)	Target	Config,Mode,Aperture	Spectral Els.	Opt. Params.	Special Reqs.	Groups	Exp. Time (Total)/[Actual Dur.]	Orbit	1	(COS.ta.100 4284)	(19) HD187876	COS/NUV, ACQ/IMAGE, BOA	MIRRORA				4 Secs (4 Secs) [==>]	[1]	2	(COS.sp.100 5139)	(19) HD187876	COS/FUV, TIME-TAG, PSA	G130M 1222 A	BUFFER-TIME=48 5; FP-POS=3			585 Secs (585 Secs) [==>]	[1]	Comments: Note: ETC simulation (for G130M-1291, so as to include Ly-alpha) is for an "extreme" FUV spectrum, scaled to V=7.2 mag, and thus will over-predict count rates for most of the targets (see Observation Description).										3	(COS.sp.100 5139)	(19) HD187876	COS/FUV, TIME-TAG, PSA	G130M 1222 A	BUFFER-TIME=48 5; FP-POS=4			585 Secs (585 Secs) [==>]	[1]	Comments: Note: ETC simulation (for G130M-1291, so as to include Ly-alpha) is for an "extreme" FUV spectrum, scaled to V=7.2 mag, and thus will over-predict count rates for most of the targets (see Observation Description).										4	(COS.sp.100 5139)	(19) HD187876	COS/FUV, TIME-TAG, PSA	G130M 1291 A	BUFFER-TIME=48 5; FP-POS=3			585 Secs (585 Secs) [==>]	[1]	Comments: Note: ETC simulation (for G130M-1291, so as to include Ly-alpha) is for an "extreme" FUV spectrum, scaled to V=7.2 mag, and thus will over-predict count rates for most of the targets (see Observation Description).										5	(COS.sp.100 5139)	(19) HD187876	COS/FUV, TIME-TAG, PSA	G130M 1291 A	BUFFER-TIME=48 5; FP-POS=4			585 Secs (585 Secs) [==>]	[1]	Comments: Note: ETC simulation (for G130M-1291, so as to include Ly-alpha) is for an "extreme" FUV spectrum, scaled to V=7.2 mag, and thus will over-predict count rates for most of the targets (see Observation Description).														
	#	Label (ETC Run)	Target	Config,Mode,Aperture	Spectral Els.	Opt. Params.	Special Reqs.	Groups	Exp. Time (Total)/[Actual Dur.]	Orbit																																																																																																
	1	(COS.ta.100 4284)	(19) HD187876	COS/NUV, ACQ/IMAGE, BOA	MIRRORA				4 Secs (4 Secs) [==>]	[1]																																																																																																
	2	(COS.sp.100 5139)	(19) HD187876	COS/FUV, TIME-TAG, PSA	G130M 1222 A	BUFFER-TIME=48 5; FP-POS=3			585 Secs (585 Secs) [==>]	[1]																																																																																																
	Comments: Note: ETC simulation (for G130M-1291, so as to include Ly-alpha) is for an "extreme" FUV spectrum, scaled to V=7.2 mag, and thus will over-predict count rates for most of the targets (see Observation Description).																																																																																																									
	3	(COS.sp.100 5139)	(19) HD187876	COS/FUV, TIME-TAG, PSA	G130M 1222 A	BUFFER-TIME=48 5; FP-POS=4			585 Secs (585 Secs) [==>]	[1]																																																																																																
Comments: Note: ETC simulation (for G130M-1291, so as to include Ly-alpha) is for an "extreme" FUV spectrum, scaled to V=7.2 mag, and thus will over-predict count rates for most of the targets (see Observation Description).																																																																																																										
4	(COS.sp.100 5139)	(19) HD187876	COS/FUV, TIME-TAG, PSA	G130M 1291 A	BUFFER-TIME=48 5; FP-POS=3			585 Secs (585 Secs) [==>]	[1]																																																																																																	
Comments: Note: ETC simulation (for G130M-1291, so as to include Ly-alpha) is for an "extreme" FUV spectrum, scaled to V=7.2 mag, and thus will over-predict count rates for most of the targets (see Observation Description).																																																																																																										
5	(COS.sp.100 5139)	(19) HD187876	COS/FUV, TIME-TAG, PSA	G130M 1291 A	BUFFER-TIME=48 5; FP-POS=4			585 Secs (585 Secs) [==>]	[1]																																																																																																	
Comments: Note: ETC simulation (for G130M-1291, so as to include Ly-alpha) is for an "extreme" FUV spectrum, scaled to V=7.2 mag, and thus will over-predict count rates for most of the targets (see Observation Description).																																																																																																										

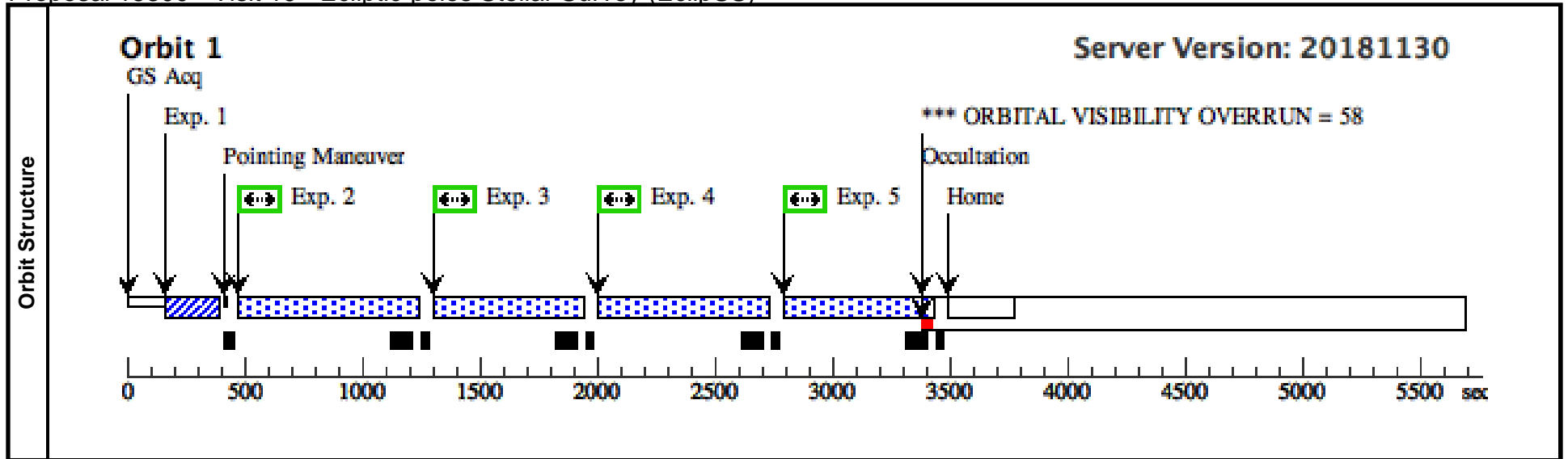

Proposal 15300 - Visit 20 - Ecliptic-poles Stellar Survey (EclipSS)

Thu Dec 13 22:02:08 GMT 2018

Visit	Proposal 15300, Visit 20, scheduling Diagnostic Status: Warning Scientific Instruments: COS/FUV, COS/NUV Special Requirements: (none)																																																																																																									
	(Visit 20) Warning (Form): For the best data quality, it is strongly recommended that the maximum number of allowed FP-POS positions is used when observing at a given COS CENWAVE setting. See full description for details. (Visit 20) Warning (Orbit Planner): ORBITAL VISIBILITY OVERRUN																																																																																																									
Diagnosics																																																																																																										
Fixed Targets	<table border="1"> <thead> <tr> <th>#</th> <th>Name</th> <th>Target Coordinates</th> <th>Targ. Coord. Corrections</th> <th>Fluxes</th> <th>Miscellaneous</th> </tr> </thead> <tbody> <tr> <td>(20)</td> <td>HD146044</td> <td>RA: 16 10 47.2523 (242.6968846d) Dec: +59 40 31.48 (59.67541d) Equinox: J2000</td> <td>Proper Motion RA: -38.45 mas/yr Proper Motion Dec: -115.41 mas/yr Parallax: 0.02396" Epoch of Position: 2000 Radial Velocity: 0.0 km/sec</td> <td>V=8.13+/-0.1 sptyp= G0V; (B-V)= 0.68 mag; dist= 43 pc</td> <td>Reference Frame: ICRS</td> </tr> </tbody> </table>	#	Name	Target Coordinates	Targ. Coord. Corrections	Fluxes	Miscellaneous	(20)	HD146044	RA: 16 10 47.2523 (242.6968846d) Dec: +59 40 31.48 (59.67541d) Equinox: J2000	Proper Motion RA: -38.45 mas/yr Proper Motion Dec: -115.41 mas/yr Parallax: 0.02396" Epoch of Position: 2000 Radial Velocity: 0.0 km/sec	V=8.13+/-0.1 sptyp= G0V; (B-V)= 0.68 mag; dist= 43 pc	Reference Frame: ICRS	Comments: Category=STAR Description=[G V-IV] Extended=NO																																																																																												
	#	Name	Target Coordinates	Targ. Coord. Corrections	Fluxes	Miscellaneous																																																																																																				
(20)	HD146044	RA: 16 10 47.2523 (242.6968846d) Dec: +59 40 31.48 (59.67541d) Equinox: J2000	Proper Motion RA: -38.45 mas/yr Proper Motion Dec: -115.41 mas/yr Parallax: 0.02396" Epoch of Position: 2000 Radial Velocity: 0.0 km/sec	V=8.13+/-0.1 sptyp= G0V; (B-V)= 0.68 mag; dist= 43 pc	Reference Frame: ICRS																																																																																																					
Exposures	<table border="1"> <thead> <tr> <th>#</th> <th>Label (ETC Run)</th> <th>Target</th> <th>Config,Mode,Aperture</th> <th>Spectral Els.</th> <th>Opt. Params.</th> <th>Special Reqs.</th> <th>Groups</th> <th>Exp. Time (Total)/[Actual Dur.]</th> <th>Orbit</th> </tr> </thead> <tbody> <tr> <td>1</td> <td>(COS.ta.100 4285)</td> <td>(20) HD146044</td> <td>COS/NUV, ACQ/IMAGE, BOA</td> <td>MIRRORA</td> <td></td> <td></td> <td></td> <td>6 Secs (6 Secs) [==>]</td> <td>[1]</td> </tr> <tr> <td>2</td> <td>(COS.sp.100 5139)</td> <td>(20) HD146044</td> <td>COS/FUV, TIME-TAG, PSA</td> <td>G130M 1222 A</td> <td>BUFFER-TIME=48 4; FP-POS=3</td> <td></td> <td></td> <td>584 Secs (584 Secs) [==>]</td> <td>[1]</td> </tr> <tr> <td colspan="10"> Comments: Note: ETC simulation (for G130M-1291, so as to include Ly-alpha) is for an "extreme" FUV spectrum, scaled to V=7.2 mag, and thus will over-predict count rates for most of the targets (see Observation Description). </td> </tr> <tr> <td>3</td> <td>(COS.sp.100 5139)</td> <td>(20) HD146044</td> <td>COS/FUV, TIME-TAG, PSA</td> <td>G130M 1222 A</td> <td>BUFFER-TIME=48 4; FP-POS=4</td> <td></td> <td></td> <td>584 Secs (584 Secs) [==>]</td> <td>[1]</td> </tr> <tr> <td colspan="10"> Comments: Note: ETC simulation (for G130M-1291, so as to include Ly-alpha) is for an "extreme" FUV spectrum, scaled to V=7.2 mag, and thus will over-predict count rates for most of the targets (see Observation Description). </td> </tr> <tr> <td>4</td> <td>(COS.sp.100 5139)</td> <td>(20) HD146044</td> <td>COS/FUV, TIME-TAG, PSA</td> <td>G130M 1291 A</td> <td>BUFFER-TIME=48 4; FP-POS=3</td> <td></td> <td></td> <td>584 Secs (584 Secs) [==>]</td> <td>[1]</td> </tr> <tr> <td colspan="10"> Comments: Note: ETC simulation (for G130M-1291, so as to include Ly-alpha) is for an "extreme" FUV spectrum, scaled to V=7.2 mag, and thus will over-predict count rates for most of the targets (see Observation Description). </td> </tr> <tr> <td>5</td> <td>(COS.sp.100 5139)</td> <td>(20) HD146044</td> <td>COS/FUV, TIME-TAG, PSA</td> <td>G130M 1291 A</td> <td>BUFFER-TIME=48 4; FP-POS=4</td> <td></td> <td></td> <td>584 Secs (584 Secs) [==>]</td> <td>[1]</td> </tr> <tr> <td colspan="10"> Comments: Note: ETC simulation (for G130M-1291, so as to include Ly-alpha) is for an "extreme" FUV spectrum, scaled to V=7.2 mag, and thus will over-predict count rates for most of the targets (see Observation Description). </td> </tr> </tbody> </table>	#	Label (ETC Run)	Target	Config,Mode,Aperture	Spectral Els.	Opt. Params.	Special Reqs.	Groups	Exp. Time (Total)/[Actual Dur.]	Orbit	1	(COS.ta.100 4285)	(20) HD146044	COS/NUV, ACQ/IMAGE, BOA	MIRRORA				6 Secs (6 Secs) [==>]	[1]	2	(COS.sp.100 5139)	(20) HD146044	COS/FUV, TIME-TAG, PSA	G130M 1222 A	BUFFER-TIME=48 4; FP-POS=3			584 Secs (584 Secs) [==>]	[1]	Comments: Note: ETC simulation (for G130M-1291, so as to include Ly-alpha) is for an "extreme" FUV spectrum, scaled to V=7.2 mag, and thus will over-predict count rates for most of the targets (see Observation Description).										3	(COS.sp.100 5139)	(20) HD146044	COS/FUV, TIME-TAG, PSA	G130M 1222 A	BUFFER-TIME=48 4; FP-POS=4			584 Secs (584 Secs) [==>]	[1]	Comments: Note: ETC simulation (for G130M-1291, so as to include Ly-alpha) is for an "extreme" FUV spectrum, scaled to V=7.2 mag, and thus will over-predict count rates for most of the targets (see Observation Description).										4	(COS.sp.100 5139)	(20) HD146044	COS/FUV, TIME-TAG, PSA	G130M 1291 A	BUFFER-TIME=48 4; FP-POS=3			584 Secs (584 Secs) [==>]	[1]	Comments: Note: ETC simulation (for G130M-1291, so as to include Ly-alpha) is for an "extreme" FUV spectrum, scaled to V=7.2 mag, and thus will over-predict count rates for most of the targets (see Observation Description).										5	(COS.sp.100 5139)	(20) HD146044	COS/FUV, TIME-TAG, PSA	G130M 1291 A	BUFFER-TIME=48 4; FP-POS=4			584 Secs (584 Secs) [==>]	[1]	Comments: Note: ETC simulation (for G130M-1291, so as to include Ly-alpha) is for an "extreme" FUV spectrum, scaled to V=7.2 mag, and thus will over-predict count rates for most of the targets (see Observation Description).														
	#	Label (ETC Run)	Target	Config,Mode,Aperture	Spectral Els.	Opt. Params.	Special Reqs.	Groups	Exp. Time (Total)/[Actual Dur.]	Orbit																																																																																																
	1	(COS.ta.100 4285)	(20) HD146044	COS/NUV, ACQ/IMAGE, BOA	MIRRORA				6 Secs (6 Secs) [==>]	[1]																																																																																																
	2	(COS.sp.100 5139)	(20) HD146044	COS/FUV, TIME-TAG, PSA	G130M 1222 A	BUFFER-TIME=48 4; FP-POS=3			584 Secs (584 Secs) [==>]	[1]																																																																																																
	Comments: Note: ETC simulation (for G130M-1291, so as to include Ly-alpha) is for an "extreme" FUV spectrum, scaled to V=7.2 mag, and thus will over-predict count rates for most of the targets (see Observation Description).																																																																																																									
	3	(COS.sp.100 5139)	(20) HD146044	COS/FUV, TIME-TAG, PSA	G130M 1222 A	BUFFER-TIME=48 4; FP-POS=4			584 Secs (584 Secs) [==>]	[1]																																																																																																
Comments: Note: ETC simulation (for G130M-1291, so as to include Ly-alpha) is for an "extreme" FUV spectrum, scaled to V=7.2 mag, and thus will over-predict count rates for most of the targets (see Observation Description).																																																																																																										
4	(COS.sp.100 5139)	(20) HD146044	COS/FUV, TIME-TAG, PSA	G130M 1291 A	BUFFER-TIME=48 4; FP-POS=3			584 Secs (584 Secs) [==>]	[1]																																																																																																	
Comments: Note: ETC simulation (for G130M-1291, so as to include Ly-alpha) is for an "extreme" FUV spectrum, scaled to V=7.2 mag, and thus will over-predict count rates for most of the targets (see Observation Description).																																																																																																										
5	(COS.sp.100 5139)	(20) HD146044	COS/FUV, TIME-TAG, PSA	G130M 1291 A	BUFFER-TIME=48 4; FP-POS=4			584 Secs (584 Secs) [==>]	[1]																																																																																																	
Comments: Note: ETC simulation (for G130M-1291, so as to include Ly-alpha) is for an "extreme" FUV spectrum, scaled to V=7.2 mag, and thus will over-predict count rates for most of the targets (see Observation Description).																																																																																																										

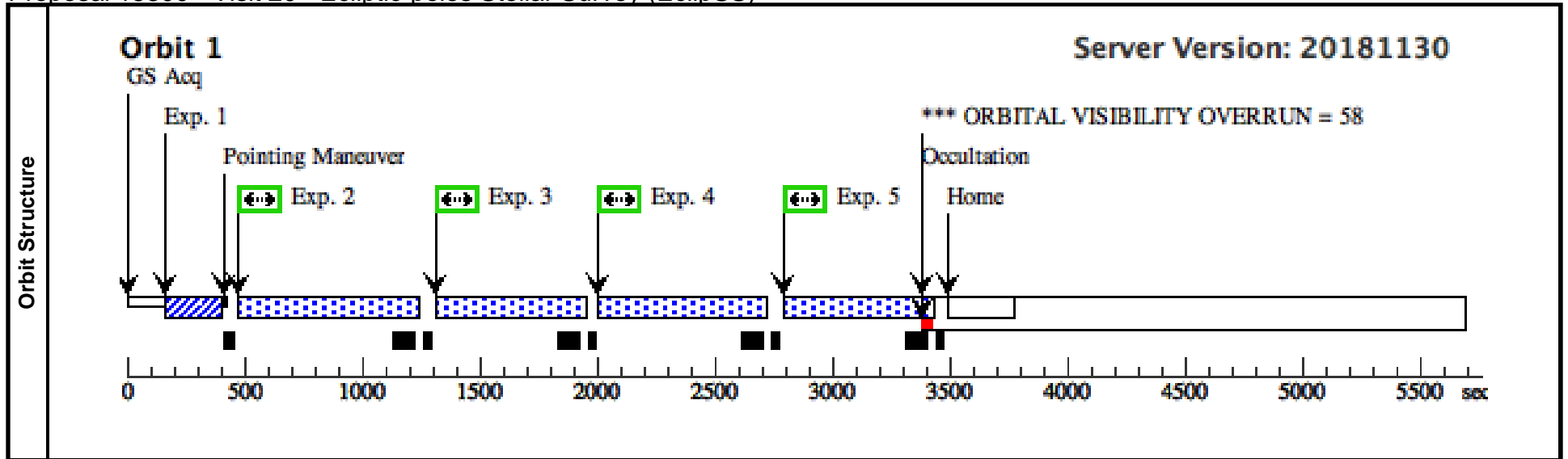

Proposal 15300 - Visit 21 - Ecliptic-poles Stellar Survey (EclipSS)

Thu Dec 13 22:02:08 GMT 2018

Visit	Proposal 15300, Visit 21, scheduled Diagnostic Status: Warning Scientific Instruments: COS/FUV, COS/NUV Special Requirements: (none)										
	(Visit 21) Warning (Form): For the best data quality, it is strongly recommended that the maximum number of allowed FP-POS positions is used when observing at a given COS CENWAVE setting. See full description for details. (Visit 21) Warning (Orbit Planner): ORBITAL VISIBILITY OVERRUN										
Fixed Targets	#	Name	Target Coordinates	Targ. Coord. Corrections	Fluxes	Miscellaneous					
	(21)	HD51929	RA: 06 55 53.2145 (103.9717271d) Dec: -56 56 32.68 (-56.94241d) Equinox: J2000	Proper Motion RA: -7.71 mas/yr Proper Motion Dec: 632.54 mas/yr Parallax: 0.02634" Epoch of Position: 2000 Radial Velocity: 0.0 km/sec	V=7.43+/-0.1 sptyp= G2V; (B-V)= 0.59 mag; dist= 38 pc	Reference Frame: ICRS					
Comments: Category=STAR Description=[G V-IV] Extended=NO											
Exposures	#	Label (ETC Run)	Target	Config,Mode,Aperture	Spectral Els.	Opt. Params.	Special Reqs.	Groups	Exp. Time (Total)/[Actual Dur.]	Orbit	
	1	(COS.ta.100 4286)	(21) HD51929	COS/NUV, ACQ/IMAGE, BOA	MIRRORA				4 Secs (4 Secs) [==>]	[1]	
	2	(COS.sp.100 5139)	(21) HD51929	COS/FUV, TIME-TAG, PSA	G130M 1222 A	BUFFER-TIME=48 5; FP-POS=3			585 Secs (585 Secs) [==>]	[1]	
	Comments: Note: ETC simulation (for G130M-1291, so as to include Ly-alpha) is for an "extreme" FUV spectrum, scaled to V=7.2 mag, and thus will over-predict count rates for most of the targets (see Observation Description).										
	3	(COS.sp.100 5139)	(21) HD51929	COS/FUV, TIME-TAG, PSA	G130M 1222 A	BUFFER-TIME=48 5; FP-POS=4			585 Secs (585 Secs) [==>]	[1]	
	Comments: Note: ETC simulation (for G130M-1291, so as to include Ly-alpha) is for an "extreme" FUV spectrum, scaled to V=7.2 mag, and thus will over-predict count rates for most of the targets (see Observation Description).										
4	(COS.sp.100 5139)	(21) HD51929	COS/FUV, TIME-TAG, PSA	G130M 1291 A	BUFFER-TIME=48 5; FP-POS=3			585 Secs (585 Secs) [==>]	[1]		
Comments: Note: ETC simulation (for G130M-1291, so as to include Ly-alpha) is for an "extreme" FUV spectrum, scaled to V=7.2 mag, and thus will over-predict count rates for most of the targets (see Observation Description).											
5	(COS.sp.100 5139)	(21) HD51929	COS/FUV, TIME-TAG, PSA	G130M 1291 A	BUFFER-TIME=48 5; FP-POS=4			585 Secs (585 Secs) [==>]	[1]		
Comments: Note: ETC simulation (for G130M-1291, so as to include Ly-alpha) is for an "extreme" FUV spectrum, scaled to V=7.2 mag, and thus will over-predict count rates for most of the targets (see Observation Description).											

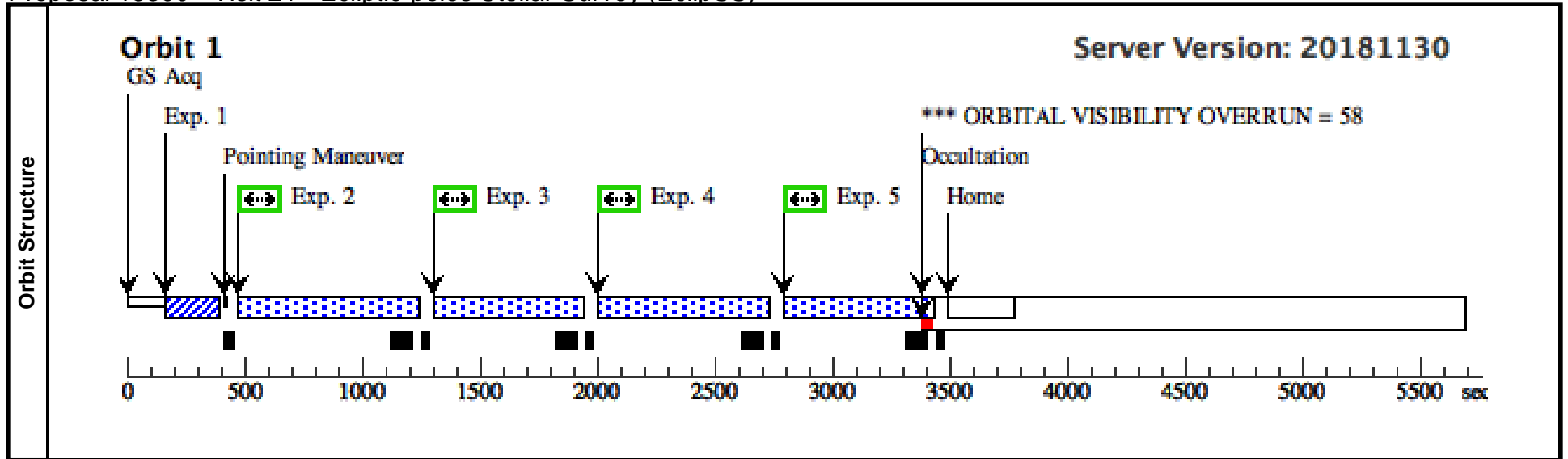

Proposal 15300 - Visit 22 - Ecliptic-poles Stellar Survey (EclipSS)

Thu Dec 13 22:02:08 GMT 2018

Visit	Proposal 15300, Visit 22, completed Diagnostic Status: Warning Scientific Instruments: COS/FUV, COS/NUV Special Requirements: (none)																																																																																																									
	(Visit 22) Warning (Form): For the best data quality, it is strongly recommended that the maximum number of allowed FP-POS positions is used when observing at a given COS CENWAVE setting. See full description for details. (Visit 22) Warning (Orbit Planner): ORBITAL VISIBILITY OVERRUN																																																																																																									
Diagnosics																																																																																																										
Fixed Targets	<table border="1"> <thead> <tr> <th>#</th> <th>Name</th> <th>Target Coordinates</th> <th>Targ. Coord. Corrections</th> <th>Fluxes</th> <th>Miscellaneous</th> </tr> </thead> <tbody> <tr> <td>(22)</td> <td>HD28701</td> <td>RA: 04 25 45.8486 (66.4410358d) Dec: -69 59 37.27 (-69.99369d) Equinox: J2000</td> <td>Proper Motion RA: 144.69 mas/yr Proper Motion Dec: 5.13 mas/yr Parallax: 0.02335" Epoch of Position: 2000 Radial Velocity: 0.0 km/sec</td> <td>V=7.87+/-0.1 sptyp= G2V; (B-V)= 0.61 mag; dist= 44 pc</td> <td>Reference Frame: ICRS</td> </tr> </tbody> </table>	#	Name	Target Coordinates	Targ. Coord. Corrections	Fluxes	Miscellaneous	(22)	HD28701	RA: 04 25 45.8486 (66.4410358d) Dec: -69 59 37.27 (-69.99369d) Equinox: J2000	Proper Motion RA: 144.69 mas/yr Proper Motion Dec: 5.13 mas/yr Parallax: 0.02335" Epoch of Position: 2000 Radial Velocity: 0.0 km/sec	V=7.87+/-0.1 sptyp= G2V; (B-V)= 0.61 mag; dist= 44 pc	Reference Frame: ICRS	Comments: Category=STAR Description=[G V-IV] Extended=NO																																																																																												
	#	Name	Target Coordinates	Targ. Coord. Corrections	Fluxes	Miscellaneous																																																																																																				
(22)	HD28701	RA: 04 25 45.8486 (66.4410358d) Dec: -69 59 37.27 (-69.99369d) Equinox: J2000	Proper Motion RA: 144.69 mas/yr Proper Motion Dec: 5.13 mas/yr Parallax: 0.02335" Epoch of Position: 2000 Radial Velocity: 0.0 km/sec	V=7.87+/-0.1 sptyp= G2V; (B-V)= 0.61 mag; dist= 44 pc	Reference Frame: ICRS																																																																																																					
Exposures	<table border="1"> <thead> <tr> <th>#</th> <th>Label (ETC Run)</th> <th>Target</th> <th>Config,Mode,Aperture</th> <th>Spectral Els.</th> <th>Opt. Params.</th> <th>Special Reqs.</th> <th>Groups</th> <th>Exp. Time (Total)/[Actual Dur.]</th> <th>Orbit</th> </tr> </thead> <tbody> <tr> <td>1</td> <td>(COS.ta.100 4287)</td> <td>(22) HD28701</td> <td>COS/NUV, ACQ/IMAGE, BOA</td> <td>MIRRORA</td> <td></td> <td></td> <td></td> <td>6 Secs (6 Secs) [==>]</td> <td>[1]</td> </tr> <tr> <td>2</td> <td>(COS.sp.100 5139)</td> <td>(22) HD28701</td> <td>COS/FUV, TIME-TAG, PSA</td> <td>G130M 1222 A</td> <td>BUFFER-TIME=50 8; FP-POS=3</td> <td></td> <td></td> <td>608 Secs (608 Secs) [==>]</td> <td>[1]</td> </tr> <tr> <td colspan="10"> Comments: Note: ETC simulation (for G130M-1291, so as to include Ly-alpha) is for an "extreme" FUV spectrum, scaled to V=7.2 mag, and thus will over-predict count rates for most of the targets (see Observation Description). </td> </tr> <tr> <td>3</td> <td>(COS.sp.100 5139)</td> <td>(22) HD28701</td> <td>COS/FUV, TIME-TAG, PSA</td> <td>G130M 1222 A</td> <td>BUFFER-TIME=50 8; FP-POS=4</td> <td></td> <td></td> <td>608 Secs (608 Secs) [==>]</td> <td>[1]</td> </tr> <tr> <td colspan="10"> Comments: Note: ETC simulation (for G130M-1291, so as to include Ly-alpha) is for an "extreme" FUV spectrum, scaled to V=7.2 mag, and thus will over-predict count rates for most of the targets (see Observation Description). </td> </tr> <tr> <td>4</td> <td>(COS.sp.100 5139)</td> <td>(22) HD28701</td> <td>COS/FUV, TIME-TAG, PSA</td> <td>G130M 1291 A</td> <td>BUFFER-TIME=50 8; FP-POS=3</td> <td></td> <td></td> <td>608 Secs (608 Secs) [==>]</td> <td>[1]</td> </tr> <tr> <td colspan="10"> Comments: Note: ETC simulation (for G130M-1291, so as to include Ly-alpha) is for an "extreme" FUV spectrum, scaled to V=7.2 mag, and thus will over-predict count rates for most of the targets (see Observation Description). </td> </tr> <tr> <td>5</td> <td>(COS.sp.100 5139)</td> <td>(22) HD28701</td> <td>COS/FUV, TIME-TAG, PSA</td> <td>G130M 1291 A</td> <td>BUFFER-TIME=50 8; FP-POS=4</td> <td></td> <td></td> <td>608 Secs (608 Secs) [==>]</td> <td>[1]</td> </tr> <tr> <td colspan="10"> Comments: Note: ETC simulation (for G130M-1291, so as to include Ly-alpha) is for an "extreme" FUV spectrum, scaled to V=7.2 mag, and thus will over-predict count rates for most of the targets (see Observation Description). </td> </tr> </tbody> </table>	#	Label (ETC Run)	Target	Config,Mode,Aperture	Spectral Els.	Opt. Params.	Special Reqs.	Groups	Exp. Time (Total)/[Actual Dur.]	Orbit	1	(COS.ta.100 4287)	(22) HD28701	COS/NUV, ACQ/IMAGE, BOA	MIRRORA				6 Secs (6 Secs) [==>]	[1]	2	(COS.sp.100 5139)	(22) HD28701	COS/FUV, TIME-TAG, PSA	G130M 1222 A	BUFFER-TIME=50 8; FP-POS=3			608 Secs (608 Secs) [==>]	[1]	Comments: Note: ETC simulation (for G130M-1291, so as to include Ly-alpha) is for an "extreme" FUV spectrum, scaled to V=7.2 mag, and thus will over-predict count rates for most of the targets (see Observation Description).										3	(COS.sp.100 5139)	(22) HD28701	COS/FUV, TIME-TAG, PSA	G130M 1222 A	BUFFER-TIME=50 8; FP-POS=4			608 Secs (608 Secs) [==>]	[1]	Comments: Note: ETC simulation (for G130M-1291, so as to include Ly-alpha) is for an "extreme" FUV spectrum, scaled to V=7.2 mag, and thus will over-predict count rates for most of the targets (see Observation Description).										4	(COS.sp.100 5139)	(22) HD28701	COS/FUV, TIME-TAG, PSA	G130M 1291 A	BUFFER-TIME=50 8; FP-POS=3			608 Secs (608 Secs) [==>]	[1]	Comments: Note: ETC simulation (for G130M-1291, so as to include Ly-alpha) is for an "extreme" FUV spectrum, scaled to V=7.2 mag, and thus will over-predict count rates for most of the targets (see Observation Description).										5	(COS.sp.100 5139)	(22) HD28701	COS/FUV, TIME-TAG, PSA	G130M 1291 A	BUFFER-TIME=50 8; FP-POS=4			608 Secs (608 Secs) [==>]	[1]	Comments: Note: ETC simulation (for G130M-1291, so as to include Ly-alpha) is for an "extreme" FUV spectrum, scaled to V=7.2 mag, and thus will over-predict count rates for most of the targets (see Observation Description).														
	#	Label (ETC Run)	Target	Config,Mode,Aperture	Spectral Els.	Opt. Params.	Special Reqs.	Groups	Exp. Time (Total)/[Actual Dur.]	Orbit																																																																																																
	1	(COS.ta.100 4287)	(22) HD28701	COS/NUV, ACQ/IMAGE, BOA	MIRRORA				6 Secs (6 Secs) [==>]	[1]																																																																																																
	2	(COS.sp.100 5139)	(22) HD28701	COS/FUV, TIME-TAG, PSA	G130M 1222 A	BUFFER-TIME=50 8; FP-POS=3			608 Secs (608 Secs) [==>]	[1]																																																																																																
	Comments: Note: ETC simulation (for G130M-1291, so as to include Ly-alpha) is for an "extreme" FUV spectrum, scaled to V=7.2 mag, and thus will over-predict count rates for most of the targets (see Observation Description).																																																																																																									
	3	(COS.sp.100 5139)	(22) HD28701	COS/FUV, TIME-TAG, PSA	G130M 1222 A	BUFFER-TIME=50 8; FP-POS=4			608 Secs (608 Secs) [==>]	[1]																																																																																																
Comments: Note: ETC simulation (for G130M-1291, so as to include Ly-alpha) is for an "extreme" FUV spectrum, scaled to V=7.2 mag, and thus will over-predict count rates for most of the targets (see Observation Description).																																																																																																										
4	(COS.sp.100 5139)	(22) HD28701	COS/FUV, TIME-TAG, PSA	G130M 1291 A	BUFFER-TIME=50 8; FP-POS=3			608 Secs (608 Secs) [==>]	[1]																																																																																																	
Comments: Note: ETC simulation (for G130M-1291, so as to include Ly-alpha) is for an "extreme" FUV spectrum, scaled to V=7.2 mag, and thus will over-predict count rates for most of the targets (see Observation Description).																																																																																																										
5	(COS.sp.100 5139)	(22) HD28701	COS/FUV, TIME-TAG, PSA	G130M 1291 A	BUFFER-TIME=50 8; FP-POS=4			608 Secs (608 Secs) [==>]	[1]																																																																																																	
Comments: Note: ETC simulation (for G130M-1291, so as to include Ly-alpha) is for an "extreme" FUV spectrum, scaled to V=7.2 mag, and thus will over-predict count rates for most of the targets (see Observation Description).																																																																																																										

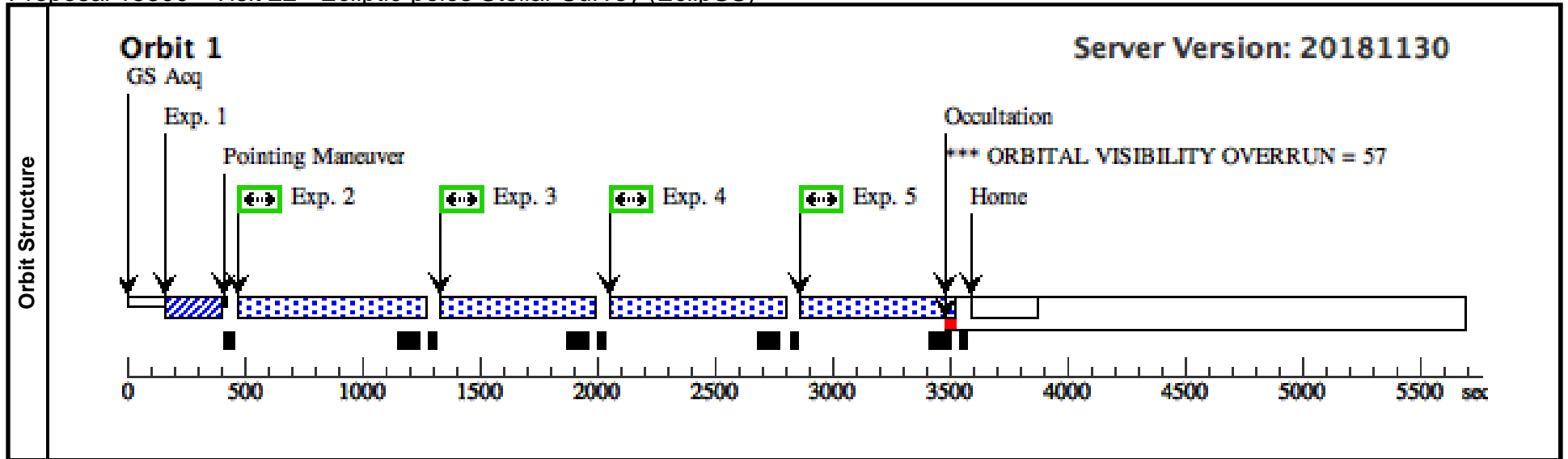

Proposal 15300 - Visit 23 - Ecliptic-poles Stellar Survey (EclipSS)

Thu Dec 13 22:02:08 GMT 2018

Visit	Proposal 15300, Visit 23, completed Diagnostic Status: Warning Scientific Instruments: COS/FUV, COS/NUV Special Requirements: (none)																																																																																																									
	(Visit 23) Warning (Form): For the best data quality, it is strongly recommended that the maximum number of allowed FP-POS positions is used when observing at a given COS CENWAVE setting. See full description for details. (Visit 23) Warning (Orbit Planner): ORBITAL VISIBILITY OVERRUN																																																																																																									
Diagnosics																																																																																																										
Fixed Targets	<table border="1"> <thead> <tr> <th>#</th> <th>Name</th> <th>Target Coordinates</th> <th>Targ. Coord. Corrections</th> <th>Fluxes</th> <th>Miscellaneous</th> </tr> </thead> <tbody> <tr> <td>(23)</td> <td>HD172669</td> <td>RA: 18 36 23.4532 (279.0977217d) Dec: +66 54 47.67 (66.91324d) Equinox: J2000</td> <td>Proper Motion RA: 69.59 mas/yr Proper Motion Dec: -57.73 mas/yr Parallax: 0.02791" Epoch of Position: 2000 Radial Velocity: 0.0 km/sec</td> <td>V=7.6+/-0.1 sptyp= G3V; (B-V)= 0.58 mag; dist= 36 pc</td> <td>Reference Frame: ICRS</td> </tr> </tbody> </table>	#	Name	Target Coordinates	Targ. Coord. Corrections	Fluxes	Miscellaneous	(23)	HD172669	RA: 18 36 23.4532 (279.0977217d) Dec: +66 54 47.67 (66.91324d) Equinox: J2000	Proper Motion RA: 69.59 mas/yr Proper Motion Dec: -57.73 mas/yr Parallax: 0.02791" Epoch of Position: 2000 Radial Velocity: 0.0 km/sec	V=7.6+/-0.1 sptyp= G3V; (B-V)= 0.58 mag; dist= 36 pc	Reference Frame: ICRS	Comments: Category=STAR Description=[G V-IV] Extended=NO																																																																																												
	#	Name	Target Coordinates	Targ. Coord. Corrections	Fluxes	Miscellaneous																																																																																																				
(23)	HD172669	RA: 18 36 23.4532 (279.0977217d) Dec: +66 54 47.67 (66.91324d) Equinox: J2000	Proper Motion RA: 69.59 mas/yr Proper Motion Dec: -57.73 mas/yr Parallax: 0.02791" Epoch of Position: 2000 Radial Velocity: 0.0 km/sec	V=7.6+/-0.1 sptyp= G3V; (B-V)= 0.58 mag; dist= 36 pc	Reference Frame: ICRS																																																																																																					
Exposures	<table border="1"> <thead> <tr> <th>#</th> <th>Label (ETC Run)</th> <th>Target</th> <th>Config,Mode,Aperture</th> <th>Spectral Els.</th> <th>Opt. Params.</th> <th>Special Reqs.</th> <th>Groups</th> <th>Exp. Time (Total)/[Actual Dur.]</th> <th>Orbit</th> </tr> </thead> <tbody> <tr> <td>1</td> <td>(COS.ta.100 4288)</td> <td>(23) HD172669</td> <td>COS/NUV, ACQ/IMAGE, BOA</td> <td>MIRRORA</td> <td></td> <td></td> <td></td> <td>4 Secs (4 Secs) [==>]</td> <td>[1]</td> </tr> <tr> <td>2</td> <td>(COS.sp.100 5139)</td> <td>(23) HD172669</td> <td>COS/FUV, TIME-TAG, PSA</td> <td>G130M 1222 A</td> <td>BUFFER-TIME=50 9; FP-POS=3</td> <td></td> <td></td> <td>609 Secs (609 Secs) [==>]</td> <td>[1]</td> </tr> <tr> <td colspan="10"> Comments: Note: ETC simulation (for G130M-1291, so as to include Ly-alpha) is for an "extreme" FUV spectrum, scaled to V=7.2 mag, and thus will over-predict count rates for most of the targets (see Observation Description). </td> </tr> <tr> <td>3</td> <td>(COS.sp.100 5139)</td> <td>(23) HD172669</td> <td>COS/FUV, TIME-TAG, PSA</td> <td>G130M 1222 A</td> <td>BUFFER-TIME=50 9; FP-POS=4</td> <td></td> <td></td> <td>609 Secs (609 Secs) [==>]</td> <td>[1]</td> </tr> <tr> <td colspan="10"> Comments: Note: ETC simulation (for G130M-1291, so as to include Ly-alpha) is for an "extreme" FUV spectrum, scaled to V=7.2 mag, and thus will over-predict count rates for most of the targets (see Observation Description). </td> </tr> <tr> <td>4</td> <td>(COS.sp.100 5139)</td> <td>(23) HD172669</td> <td>COS/FUV, TIME-TAG, PSA</td> <td>G130M 1291 A</td> <td>BUFFER-TIME=50 9; FP-POS=3</td> <td></td> <td></td> <td>609 Secs (609 Secs) [==>]</td> <td>[1]</td> </tr> <tr> <td colspan="10"> Comments: Note: ETC simulation (for G130M-1291, so as to include Ly-alpha) is for an "extreme" FUV spectrum, scaled to V=7.2 mag, and thus will over-predict count rates for most of the targets (see Observation Description). </td> </tr> <tr> <td>5</td> <td>(COS.sp.100 5139)</td> <td>(23) HD172669</td> <td>COS/FUV, TIME-TAG, PSA</td> <td>G130M 1291 A</td> <td>BUFFER-TIME=50 9; FP-POS=4</td> <td></td> <td></td> <td>609 Secs (609 Secs) [==>]</td> <td>[1]</td> </tr> <tr> <td colspan="10"> Comments: Note: ETC simulation (for G130M-1291, so as to include Ly-alpha) is for an "extreme" FUV spectrum, scaled to V=7.2 mag, and thus will over-predict count rates for most of the targets (see Observation Description). </td> </tr> </tbody> </table>	#	Label (ETC Run)	Target	Config,Mode,Aperture	Spectral Els.	Opt. Params.	Special Reqs.	Groups	Exp. Time (Total)/[Actual Dur.]	Orbit	1	(COS.ta.100 4288)	(23) HD172669	COS/NUV, ACQ/IMAGE, BOA	MIRRORA				4 Secs (4 Secs) [==>]	[1]	2	(COS.sp.100 5139)	(23) HD172669	COS/FUV, TIME-TAG, PSA	G130M 1222 A	BUFFER-TIME=50 9; FP-POS=3			609 Secs (609 Secs) [==>]	[1]	Comments: Note: ETC simulation (for G130M-1291, so as to include Ly-alpha) is for an "extreme" FUV spectrum, scaled to V=7.2 mag, and thus will over-predict count rates for most of the targets (see Observation Description).										3	(COS.sp.100 5139)	(23) HD172669	COS/FUV, TIME-TAG, PSA	G130M 1222 A	BUFFER-TIME=50 9; FP-POS=4			609 Secs (609 Secs) [==>]	[1]	Comments: Note: ETC simulation (for G130M-1291, so as to include Ly-alpha) is for an "extreme" FUV spectrum, scaled to V=7.2 mag, and thus will over-predict count rates for most of the targets (see Observation Description).										4	(COS.sp.100 5139)	(23) HD172669	COS/FUV, TIME-TAG, PSA	G130M 1291 A	BUFFER-TIME=50 9; FP-POS=3			609 Secs (609 Secs) [==>]	[1]	Comments: Note: ETC simulation (for G130M-1291, so as to include Ly-alpha) is for an "extreme" FUV spectrum, scaled to V=7.2 mag, and thus will over-predict count rates for most of the targets (see Observation Description).										5	(COS.sp.100 5139)	(23) HD172669	COS/FUV, TIME-TAG, PSA	G130M 1291 A	BUFFER-TIME=50 9; FP-POS=4			609 Secs (609 Secs) [==>]	[1]	Comments: Note: ETC simulation (for G130M-1291, so as to include Ly-alpha) is for an "extreme" FUV spectrum, scaled to V=7.2 mag, and thus will over-predict count rates for most of the targets (see Observation Description).														
	#	Label (ETC Run)	Target	Config,Mode,Aperture	Spectral Els.	Opt. Params.	Special Reqs.	Groups	Exp. Time (Total)/[Actual Dur.]	Orbit																																																																																																
	1	(COS.ta.100 4288)	(23) HD172669	COS/NUV, ACQ/IMAGE, BOA	MIRRORA				4 Secs (4 Secs) [==>]	[1]																																																																																																
	2	(COS.sp.100 5139)	(23) HD172669	COS/FUV, TIME-TAG, PSA	G130M 1222 A	BUFFER-TIME=50 9; FP-POS=3			609 Secs (609 Secs) [==>]	[1]																																																																																																
	Comments: Note: ETC simulation (for G130M-1291, so as to include Ly-alpha) is for an "extreme" FUV spectrum, scaled to V=7.2 mag, and thus will over-predict count rates for most of the targets (see Observation Description).																																																																																																									
	3	(COS.sp.100 5139)	(23) HD172669	COS/FUV, TIME-TAG, PSA	G130M 1222 A	BUFFER-TIME=50 9; FP-POS=4			609 Secs (609 Secs) [==>]	[1]																																																																																																
Comments: Note: ETC simulation (for G130M-1291, so as to include Ly-alpha) is for an "extreme" FUV spectrum, scaled to V=7.2 mag, and thus will over-predict count rates for most of the targets (see Observation Description).																																																																																																										
4	(COS.sp.100 5139)	(23) HD172669	COS/FUV, TIME-TAG, PSA	G130M 1291 A	BUFFER-TIME=50 9; FP-POS=3			609 Secs (609 Secs) [==>]	[1]																																																																																																	
Comments: Note: ETC simulation (for G130M-1291, so as to include Ly-alpha) is for an "extreme" FUV spectrum, scaled to V=7.2 mag, and thus will over-predict count rates for most of the targets (see Observation Description).																																																																																																										
5	(COS.sp.100 5139)	(23) HD172669	COS/FUV, TIME-TAG, PSA	G130M 1291 A	BUFFER-TIME=50 9; FP-POS=4			609 Secs (609 Secs) [==>]	[1]																																																																																																	
Comments: Note: ETC simulation (for G130M-1291, so as to include Ly-alpha) is for an "extreme" FUV spectrum, scaled to V=7.2 mag, and thus will over-predict count rates for most of the targets (see Observation Description).																																																																																																										

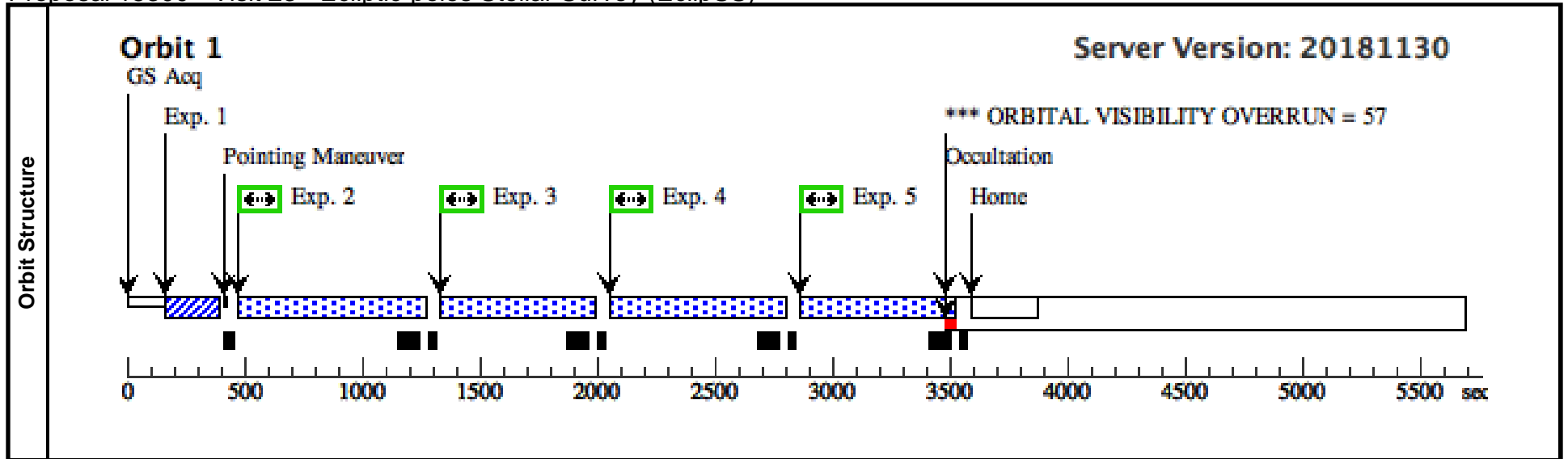

Proposal 15300 - Visit 24 - Ecliptic-poles Stellar Survey (EclipSS)

Thu Dec 13 22:02:08 GMT 2018

Visit	Proposal 15300, Visit 24, scheduled Diagnostic Status: Warning Scientific Instruments: COS/FUV, COS/NUV Special Requirements: (none)																																																																																																									
	(Visit 24) Warning (Form): For the best data quality, it is strongly recommended that the maximum number of allowed FP-POS positions is used when observing at a given COS CENWAVE setting. See full description for details. (Visit 24) Warning (Orbit Planner): ORBITAL VISIBILITY OVERRUN																																																																																																									
Diagnosics																																																																																																										
Fixed Targets	<table border="1"> <thead> <tr> <th>#</th> <th>Name</th> <th>Target Coordinates</th> <th>Targ. Coord. Corrections</th> <th>Fluxes</th> <th>Miscellaneous</th> </tr> </thead> <tbody> <tr> <td>(24)</td> <td>HD150706</td> <td>RA: 16 31 17.5855 (247.8232729d) Dec: +79 47 23.20 (79.78978d) Equinox: J2000</td> <td>Proper Motion RA: 95.77 mas/yr Proper Motion Dec: -86.40 mas/yr Parallax: 0.03543" Epoch of Position: 2000 Radial Velocity: 0.0 km/sec</td> <td>V=7.02+/-0.1 sptyp= G3V; (B-V)= 0.60 mag; dist= 28 pc</td> <td>Reference Frame: ICRS</td> </tr> </tbody> </table>	#	Name	Target Coordinates	Targ. Coord. Corrections	Fluxes	Miscellaneous	(24)	HD150706	RA: 16 31 17.5855 (247.8232729d) Dec: +79 47 23.20 (79.78978d) Equinox: J2000	Proper Motion RA: 95.77 mas/yr Proper Motion Dec: -86.40 mas/yr Parallax: 0.03543" Epoch of Position: 2000 Radial Velocity: 0.0 km/sec	V=7.02+/-0.1 sptyp= G3V; (B-V)= 0.60 mag; dist= 28 pc	Reference Frame: ICRS	Comments: Category=STAR Description=[G V-IV] Extended=NO																																																																																												
	#	Name	Target Coordinates	Targ. Coord. Corrections	Fluxes	Miscellaneous																																																																																																				
(24)	HD150706	RA: 16 31 17.5855 (247.8232729d) Dec: +79 47 23.20 (79.78978d) Equinox: J2000	Proper Motion RA: 95.77 mas/yr Proper Motion Dec: -86.40 mas/yr Parallax: 0.03543" Epoch of Position: 2000 Radial Velocity: 0.0 km/sec	V=7.02+/-0.1 sptyp= G3V; (B-V)= 0.60 mag; dist= 28 pc	Reference Frame: ICRS																																																																																																					
Exposures	<table border="1"> <thead> <tr> <th>#</th> <th>Label (ETC Run)</th> <th>Target</th> <th>Config,Mode,Aperture</th> <th>Spectral Els.</th> <th>Opt. Params.</th> <th>Special Reqs.</th> <th>Groups</th> <th>Exp. Time (Total)/[Actual Dur.]</th> <th>Orbit</th> </tr> </thead> <tbody> <tr> <td>1</td> <td>(COS.ta.100 4290)</td> <td>(24) HD150706</td> <td>COS/NUV, ACQ/IMAGE, BOA</td> <td>MIRRORB</td> <td></td> <td></td> <td></td> <td>45 Secs (45 Secs) [==>]</td> <td>[1]</td> </tr> <tr> <td>2</td> <td>(COS.sp.100 5139)</td> <td>(24) HD150706</td> <td>COS/FUV, TIME-TAG, PSA</td> <td>G130M 1222 A</td> <td>BUFFER-TIME=49 7; FP-POS=3</td> <td></td> <td></td> <td>597 Secs (597 Secs) [==>]</td> <td>[1]</td> </tr> <tr> <td colspan="10"> Comments: Note: ETC simulation (for G130M-1291, so as to include Ly-alpha) is for an "extreme" FUV spectrum, scaled to V=7.2 mag, and thus will over-predict count rates for most of the targets (see Observation Description). </td> </tr> <tr> <td>3</td> <td>(COS.sp.100 5139)</td> <td>(24) HD150706</td> <td>COS/FUV, TIME-TAG, PSA</td> <td>G130M 1222 A</td> <td>BUFFER-TIME=49 7; FP-POS=4</td> <td></td> <td></td> <td>597 Secs (597 Secs) [==>]</td> <td>[1]</td> </tr> <tr> <td colspan="10"> Comments: Note: ETC simulation (for G130M-1291, so as to include Ly-alpha) is for an "extreme" FUV spectrum, scaled to V=7.2 mag, and thus will over-predict count rates for most of the targets (see Observation Description). </td> </tr> <tr> <td>4</td> <td>(COS.sp.100 5139)</td> <td>(24) HD150706</td> <td>COS/FUV, TIME-TAG, PSA</td> <td>G130M 1291 A</td> <td>BUFFER-TIME=49 7; FP-POS=3</td> <td></td> <td></td> <td>597 Secs (597 Secs) [==>]</td> <td>[1]</td> </tr> <tr> <td colspan="10"> Comments: Note: ETC simulation (for G130M-1291, so as to include Ly-alpha) is for an "extreme" FUV spectrum, scaled to V=7.2 mag, and thus will over-predict count rates for most of the targets (see Observation Description). </td> </tr> <tr> <td>5</td> <td>(COS.sp.100 5139)</td> <td>(24) HD150706</td> <td>COS/FUV, TIME-TAG, PSA</td> <td>G130M 1291 A</td> <td>BUFFER-TIME=49 7; FP-POS=4</td> <td></td> <td></td> <td>597 Secs (597 Secs) [==>]</td> <td>[1]</td> </tr> <tr> <td colspan="10"> Comments: Note: ETC simulation (for G130M-1291, so as to include Ly-alpha) is for an "extreme" FUV spectrum, scaled to V=7.2 mag, and thus will over-predict count rates for most of the targets (see Observation Description). </td> </tr> </tbody> </table>	#	Label (ETC Run)	Target	Config,Mode,Aperture	Spectral Els.	Opt. Params.	Special Reqs.	Groups	Exp. Time (Total)/[Actual Dur.]	Orbit	1	(COS.ta.100 4290)	(24) HD150706	COS/NUV, ACQ/IMAGE, BOA	MIRRORB				45 Secs (45 Secs) [==>]	[1]	2	(COS.sp.100 5139)	(24) HD150706	COS/FUV, TIME-TAG, PSA	G130M 1222 A	BUFFER-TIME=49 7; FP-POS=3			597 Secs (597 Secs) [==>]	[1]	Comments: Note: ETC simulation (for G130M-1291, so as to include Ly-alpha) is for an "extreme" FUV spectrum, scaled to V=7.2 mag, and thus will over-predict count rates for most of the targets (see Observation Description).										3	(COS.sp.100 5139)	(24) HD150706	COS/FUV, TIME-TAG, PSA	G130M 1222 A	BUFFER-TIME=49 7; FP-POS=4			597 Secs (597 Secs) [==>]	[1]	Comments: Note: ETC simulation (for G130M-1291, so as to include Ly-alpha) is for an "extreme" FUV spectrum, scaled to V=7.2 mag, and thus will over-predict count rates for most of the targets (see Observation Description).										4	(COS.sp.100 5139)	(24) HD150706	COS/FUV, TIME-TAG, PSA	G130M 1291 A	BUFFER-TIME=49 7; FP-POS=3			597 Secs (597 Secs) [==>]	[1]	Comments: Note: ETC simulation (for G130M-1291, so as to include Ly-alpha) is for an "extreme" FUV spectrum, scaled to V=7.2 mag, and thus will over-predict count rates for most of the targets (see Observation Description).										5	(COS.sp.100 5139)	(24) HD150706	COS/FUV, TIME-TAG, PSA	G130M 1291 A	BUFFER-TIME=49 7; FP-POS=4			597 Secs (597 Secs) [==>]	[1]	Comments: Note: ETC simulation (for G130M-1291, so as to include Ly-alpha) is for an "extreme" FUV spectrum, scaled to V=7.2 mag, and thus will over-predict count rates for most of the targets (see Observation Description).														
	#	Label (ETC Run)	Target	Config,Mode,Aperture	Spectral Els.	Opt. Params.	Special Reqs.	Groups	Exp. Time (Total)/[Actual Dur.]	Orbit																																																																																																
	1	(COS.ta.100 4290)	(24) HD150706	COS/NUV, ACQ/IMAGE, BOA	MIRRORB				45 Secs (45 Secs) [==>]	[1]																																																																																																
	2	(COS.sp.100 5139)	(24) HD150706	COS/FUV, TIME-TAG, PSA	G130M 1222 A	BUFFER-TIME=49 7; FP-POS=3			597 Secs (597 Secs) [==>]	[1]																																																																																																
	Comments: Note: ETC simulation (for G130M-1291, so as to include Ly-alpha) is for an "extreme" FUV spectrum, scaled to V=7.2 mag, and thus will over-predict count rates for most of the targets (see Observation Description).																																																																																																									
	3	(COS.sp.100 5139)	(24) HD150706	COS/FUV, TIME-TAG, PSA	G130M 1222 A	BUFFER-TIME=49 7; FP-POS=4			597 Secs (597 Secs) [==>]	[1]																																																																																																
Comments: Note: ETC simulation (for G130M-1291, so as to include Ly-alpha) is for an "extreme" FUV spectrum, scaled to V=7.2 mag, and thus will over-predict count rates for most of the targets (see Observation Description).																																																																																																										
4	(COS.sp.100 5139)	(24) HD150706	COS/FUV, TIME-TAG, PSA	G130M 1291 A	BUFFER-TIME=49 7; FP-POS=3			597 Secs (597 Secs) [==>]	[1]																																																																																																	
Comments: Note: ETC simulation (for G130M-1291, so as to include Ly-alpha) is for an "extreme" FUV spectrum, scaled to V=7.2 mag, and thus will over-predict count rates for most of the targets (see Observation Description).																																																																																																										
5	(COS.sp.100 5139)	(24) HD150706	COS/FUV, TIME-TAG, PSA	G130M 1291 A	BUFFER-TIME=49 7; FP-POS=4			597 Secs (597 Secs) [==>]	[1]																																																																																																	
Comments: Note: ETC simulation (for G130M-1291, so as to include Ly-alpha) is for an "extreme" FUV spectrum, scaled to V=7.2 mag, and thus will over-predict count rates for most of the targets (see Observation Description).																																																																																																										

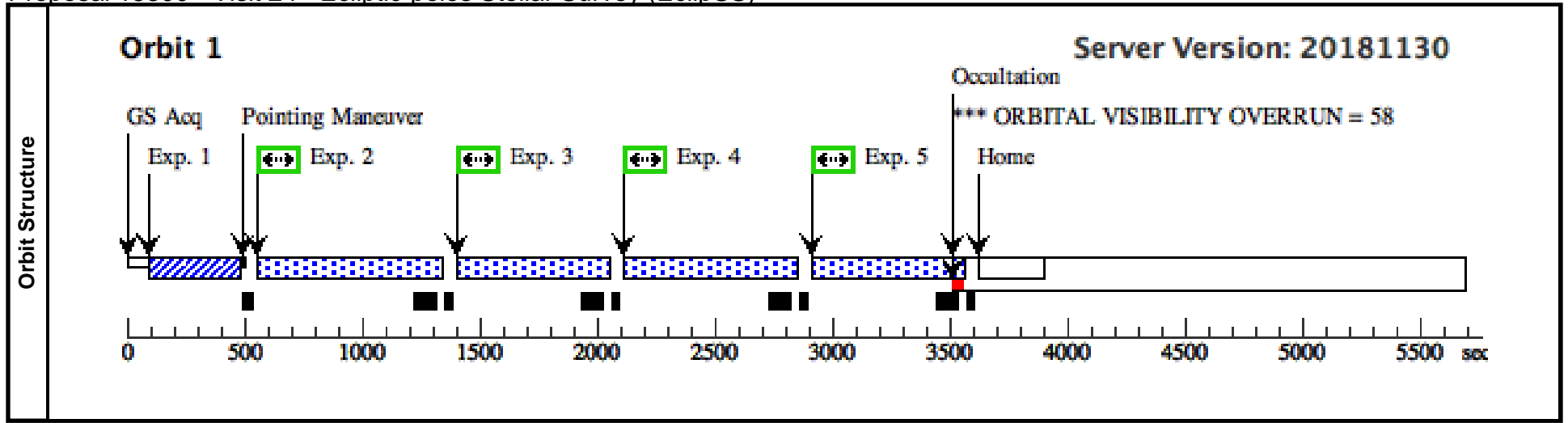

Proposal 15300 - Visit 25 - Ecliptic-poles Stellar Survey (EclipSS)

Thu Dec 13 22:02:08 GMT 2018

Visit	Proposal 15300, Visit 25, completed Diagnostic Status: Warning Scientific Instruments: COS/FUV, COS/NUV Special Requirements: (none)																																																																																																				
	(Visit 25) Warning (Form): For the best data quality, it is strongly recommended that the maximum number of allowed FP-POS positions is used when observing at a given COS CENWAVE setting. See full description for details. (Visit 25) Warning (Orbit Planner): ORBITAL VISIBILITY OVERRUN																																																																																																				
Fixed Targets	<table border="1"> <thead> <tr> <th>#</th> <th>Name</th> <th>Target Coordinates</th> <th>Targ. Coord. Corrections</th> <th>Fluxes</th> <th>Miscellaneous</th> </tr> </thead> <tbody> <tr> <td>(25)</td> <td>HD62850</td> <td>RA: 07 42 36.0630 (115.6502625d) Dec: -59 17 50.75 (-59.29743d) Equinox: J2000</td> <td>Proper Motion RA: -53.10 mas/yr Proper Motion Dec: 157.20 mas/yr Parallax: 0.03048" Epoch of Position: 2000 Radial Velocity: 0.0 km/sec</td> <td>V=7.19+/-0.1 sptyp= G3V; (B-V)= 0.64 mag; dist= 33 pc</td> <td>Reference Frame: ICRS</td> </tr> </tbody> </table>	#	Name	Target Coordinates	Targ. Coord. Corrections	Fluxes	Miscellaneous	(25)	HD62850	RA: 07 42 36.0630 (115.6502625d) Dec: -59 17 50.75 (-59.29743d) Equinox: J2000	Proper Motion RA: -53.10 mas/yr Proper Motion Dec: 157.20 mas/yr Parallax: 0.03048" Epoch of Position: 2000 Radial Velocity: 0.0 km/sec	V=7.19+/-0.1 sptyp= G3V; (B-V)= 0.64 mag; dist= 33 pc	Reference Frame: ICRS	<i>Comments:</i> Category=STAR Description=[G V-IV] Extended=NO																																																																																							
	#	Name	Target Coordinates	Targ. Coord. Corrections	Fluxes	Miscellaneous																																																																																															
(25)	HD62850	RA: 07 42 36.0630 (115.6502625d) Dec: -59 17 50.75 (-59.29743d) Equinox: J2000	Proper Motion RA: -53.10 mas/yr Proper Motion Dec: 157.20 mas/yr Parallax: 0.03048" Epoch of Position: 2000 Radial Velocity: 0.0 km/sec	V=7.19+/-0.1 sptyp= G3V; (B-V)= 0.64 mag; dist= 33 pc	Reference Frame: ICRS																																																																																																
Exposures	<table border="1"> <thead> <tr> <th>#</th> <th>Label (ETC Run)</th> <th>Target</th> <th>Config,Mode,Aperture</th> <th>Spectral Els.</th> <th>Opt. Params.</th> <th>Special Reqs.</th> <th>Groups</th> <th>Exp. Time (Total)/[Actual Dur.]</th> <th>Orbit</th> </tr> </thead> <tbody> <tr> <td>1</td> <td>(COS.ta.100 4291)</td> <td>(25) HD62850</td> <td>COS/NUV, ACQ/IMAGE, BOA</td> <td>MIRRORB</td> <td></td> <td></td> <td></td> <td>54 Secs (54 Secs) [==>]</td> <td>[1]</td> </tr> <tr> <td>2</td> <td>(COS.sp.100 5139)</td> <td>(25) HD62850</td> <td>COS/FUV, TIME-TAG, PSA</td> <td>G130M 1222 A</td> <td>BUFFER-TIME=46 0; FP-POS=3</td> <td></td> <td></td> <td>560 Secs (560 Secs) [==>]</td> <td>[1]</td> </tr> <tr> <td colspan="10"><i>Comments: Note: ETC simulation (for G130M-1291, so as to include Ly-alpha) is for an "extreme" FUV spectrum, scaled to V=7.2 mag, and thus will over-predict count rates for most of the targets (see Observation Description).</i></td> </tr> <tr> <td>3</td> <td>(COS.sp.100 5139)</td> <td>(25) HD62850</td> <td>COS/FUV, TIME-TAG, PSA</td> <td>G130M 1222 A</td> <td>BUFFER-TIME=46 0; FP-POS=4</td> <td></td> <td></td> <td>560 Secs (560 Secs) [==>]</td> <td>[1]</td> </tr> <tr> <td colspan="10"><i>Comments: Note: ETC simulation (for G130M-1291, so as to include Ly-alpha) is for an "extreme" FUV spectrum, scaled to V=7.2 mag, and thus will over-predict count rates for most of the targets (see Observation Description).</i></td> </tr> <tr> <td>4</td> <td>(COS.sp.100 5139)</td> <td>(25) HD62850</td> <td>COS/FUV, TIME-TAG, PSA</td> <td>G130M 1291 A</td> <td>BUFFER-TIME=46 0; FP-POS=3</td> <td></td> <td></td> <td>560 Secs (560 Secs) [==>]</td> <td>[1]</td> </tr> <tr> <td colspan="10"><i>Comments: Note: ETC simulation (for G130M-1291, so as to include Ly-alpha) is for an "extreme" FUV spectrum, scaled to V=7.2 mag, and thus will over-predict count rates for most of the targets (see Observation Description).</i></td> </tr> <tr> <td>5</td> <td>(COS.sp.100 5139)</td> <td>(25) HD62850</td> <td>COS/FUV, TIME-TAG, PSA</td> <td>G130M 1291 A</td> <td>BUFFER-TIME=46 0; FP-POS=4</td> <td></td> <td></td> <td>560 Secs (560 Secs) [==>]</td> <td>[1]</td> </tr> <tr> <td colspan="10"><i>Comments: Note: ETC simulation (for G130M-1291, so as to include Ly-alpha) is for an "extreme" FUV spectrum, scaled to V=7.2 mag, and thus will over-predict count rates for most of the targets (see Observation Description).</i></td> </tr> </tbody> </table>	#	Label (ETC Run)	Target	Config,Mode,Aperture	Spectral Els.	Opt. Params.	Special Reqs.	Groups	Exp. Time (Total)/[Actual Dur.]	Orbit	1	(COS.ta.100 4291)	(25) HD62850	COS/NUV, ACQ/IMAGE, BOA	MIRRORB				54 Secs (54 Secs) [==>]	[1]	2	(COS.sp.100 5139)	(25) HD62850	COS/FUV, TIME-TAG, PSA	G130M 1222 A	BUFFER-TIME=46 0; FP-POS=3			560 Secs (560 Secs) [==>]	[1]	<i>Comments: Note: ETC simulation (for G130M-1291, so as to include Ly-alpha) is for an "extreme" FUV spectrum, scaled to V=7.2 mag, and thus will over-predict count rates for most of the targets (see Observation Description).</i>										3	(COS.sp.100 5139)	(25) HD62850	COS/FUV, TIME-TAG, PSA	G130M 1222 A	BUFFER-TIME=46 0; FP-POS=4			560 Secs (560 Secs) [==>]	[1]	<i>Comments: Note: ETC simulation (for G130M-1291, so as to include Ly-alpha) is for an "extreme" FUV spectrum, scaled to V=7.2 mag, and thus will over-predict count rates for most of the targets (see Observation Description).</i>										4	(COS.sp.100 5139)	(25) HD62850	COS/FUV, TIME-TAG, PSA	G130M 1291 A	BUFFER-TIME=46 0; FP-POS=3			560 Secs (560 Secs) [==>]	[1]	<i>Comments: Note: ETC simulation (for G130M-1291, so as to include Ly-alpha) is for an "extreme" FUV spectrum, scaled to V=7.2 mag, and thus will over-predict count rates for most of the targets (see Observation Description).</i>										5	(COS.sp.100 5139)	(25) HD62850	COS/FUV, TIME-TAG, PSA	G130M 1291 A	BUFFER-TIME=46 0; FP-POS=4			560 Secs (560 Secs) [==>]	[1]	<i>Comments: Note: ETC simulation (for G130M-1291, so as to include Ly-alpha) is for an "extreme" FUV spectrum, scaled to V=7.2 mag, and thus will over-predict count rates for most of the targets (see Observation Description).</i>									
	#	Label (ETC Run)	Target	Config,Mode,Aperture	Spectral Els.	Opt. Params.	Special Reqs.	Groups	Exp. Time (Total)/[Actual Dur.]	Orbit																																																																																											
	1	(COS.ta.100 4291)	(25) HD62850	COS/NUV, ACQ/IMAGE, BOA	MIRRORB				54 Secs (54 Secs) [==>]	[1]																																																																																											
	2	(COS.sp.100 5139)	(25) HD62850	COS/FUV, TIME-TAG, PSA	G130M 1222 A	BUFFER-TIME=46 0; FP-POS=3			560 Secs (560 Secs) [==>]	[1]																																																																																											
	<i>Comments: Note: ETC simulation (for G130M-1291, so as to include Ly-alpha) is for an "extreme" FUV spectrum, scaled to V=7.2 mag, and thus will over-predict count rates for most of the targets (see Observation Description).</i>																																																																																																				
	3	(COS.sp.100 5139)	(25) HD62850	COS/FUV, TIME-TAG, PSA	G130M 1222 A	BUFFER-TIME=46 0; FP-POS=4			560 Secs (560 Secs) [==>]	[1]																																																																																											
<i>Comments: Note: ETC simulation (for G130M-1291, so as to include Ly-alpha) is for an "extreme" FUV spectrum, scaled to V=7.2 mag, and thus will over-predict count rates for most of the targets (see Observation Description).</i>																																																																																																					
4	(COS.sp.100 5139)	(25) HD62850	COS/FUV, TIME-TAG, PSA	G130M 1291 A	BUFFER-TIME=46 0; FP-POS=3			560 Secs (560 Secs) [==>]	[1]																																																																																												
<i>Comments: Note: ETC simulation (for G130M-1291, so as to include Ly-alpha) is for an "extreme" FUV spectrum, scaled to V=7.2 mag, and thus will over-predict count rates for most of the targets (see Observation Description).</i>																																																																																																					
5	(COS.sp.100 5139)	(25) HD62850	COS/FUV, TIME-TAG, PSA	G130M 1291 A	BUFFER-TIME=46 0; FP-POS=4			560 Secs (560 Secs) [==>]	[1]																																																																																												
<i>Comments: Note: ETC simulation (for G130M-1291, so as to include Ly-alpha) is for an "extreme" FUV spectrum, scaled to V=7.2 mag, and thus will over-predict count rates for most of the targets (see Observation Description).</i>																																																																																																					

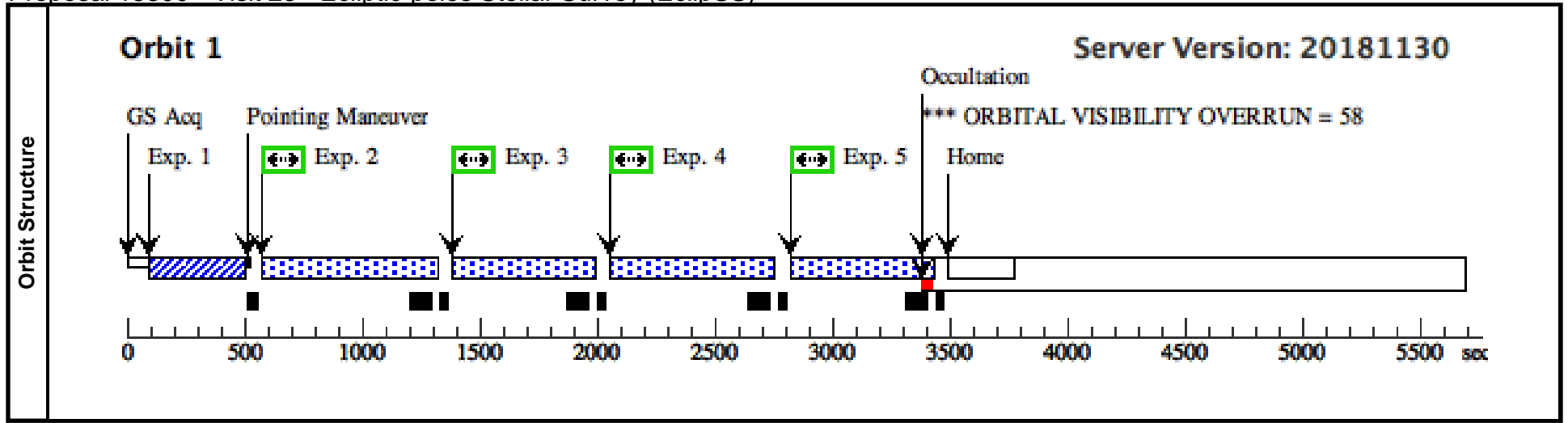

Proposal 15300 - Visit 26 - Ecliptic-poles Stellar Survey (EclipSS)

Thu Dec 13 22:02:08 GMT 2018

Visit	Proposal 15300, Visit 26, completed Diagnostic Status: Warning Scientific Instruments: COS/FUV, COS/NUV Special Requirements: (none)									
	(Visit 26) Warning (Form): For the best data quality, it is strongly recommended that the maximum number of allowed FP-POS positions is used when observing at a given COS CENWAVE setting. See full description for details. (Visit 26) Warning (Orbit Planner): ORBITAL VISIBILITY OVERRUN									
Diagnosics										
Fixed Targets	#	Name	Target Coordinates	Targ. Coord. Corrections	Fluxes	Miscellaneous				
	(26)	HD24293	RA: 03 48 1.1191 (57.0046629d) Dec: -64 50 11.73 (-64.83659d) Equinox: J2000	Proper Motion RA: 331.10 mas/yr Proper Motion Dec: 95.85 mas/yr Parallax: 0.02468" Epoch of Position: 2000 Radial Velocity: 0.0 km/sec	V=7.85+/-0.1 sptyp= G3V; (B-V)= 0.65 mag; dist= 43 pc	Reference Frame: ICRS				
Comments: Category=STAR Description=[G V-IV] Extended=NO										
Exposures	#	Label (ETC Run)	Target	Config,Mode,Aperture	Spectral Els.	Opt. Params.	Special Reqs.	Groups	Exp. Time (Total)/[Actual Dur.]	Orbit
	1	(COS.ta.100 4293)	(26) HD24293	COS/NUV, ACQ/IMAGE, BOA	MIRRORA				7 Secs (7 Secs) [==>]	[1]
2	(COS.sp.100 5139)	(26) HD24293	COS/FUV, TIME-TAG, PSA	G130M 1222 A	9; FP-POS=3			589 Secs (589 Secs) [==>]	[1]	
Comments: Note: ETC simulation (for G130M-1291, so as to include Ly-alpha) is for an "extreme" FUV spectrum, scaled to V=7.2 mag, and thus will over-predict count rates for most of the targets (see Observation Description).										
3	(COS.sp.100 5139)	(26) HD24293	COS/FUV, TIME-TAG, PSA	G130M 1222 A	9; FP-POS=4			589 Secs (589 Secs) [==>]	[1]	
Comments: Note: ETC simulation (for G130M-1291, so as to include Ly-alpha) is for an "extreme" FUV spectrum, scaled to V=7.2 mag, and thus will over-predict count rates for most of the targets (see Observation Description).										
4	(COS.sp.100 5139)	(26) HD24293	COS/FUV, TIME-TAG, PSA	G130M 1291 A	9; FP-POS=3			589 Secs (589 Secs) [==>]	[1]	
Comments: Note: ETC simulation (for G130M-1291, so as to include Ly-alpha) is for an "extreme" FUV spectrum, scaled to V=7.2 mag, and thus will over-predict count rates for most of the targets (see Observation Description).										
5	(COS.sp.100 5139)	(26) HD24293	COS/FUV, TIME-TAG, PSA	G130M 1291 A	9; FP-POS=4			589 Secs (589 Secs) [==>]	[1]	
Comments: Note: ETC simulation (for G130M-1291, so as to include Ly-alpha) is for an "extreme" FUV spectrum, scaled to V=7.2 mag, and thus will over-predict count rates for most of the targets (see Observation Description).										

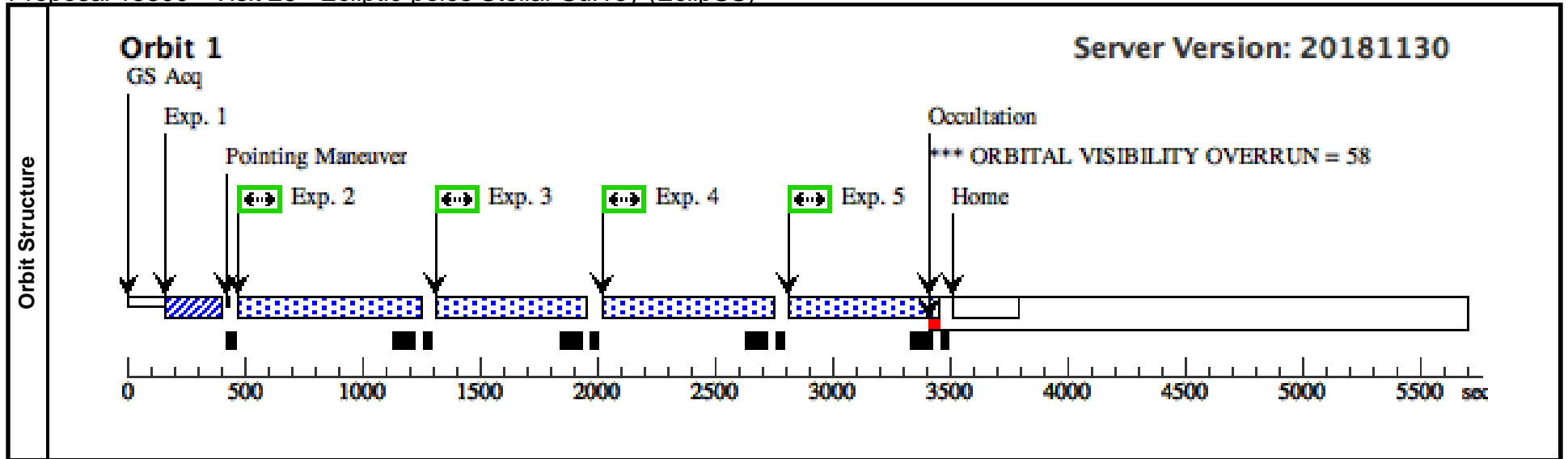

Proposal 15300 - Visit 27 - Ecliptic-poles Stellar Survey (EclipSS)

Thu Dec 13 22:02:08 GMT 2018

Visit	Proposal 15300, Visit 27, completed Diagnostic Status: Warning Scientific Instruments: COS/FUV, COS/NUV Special Requirements: (none)									
	(Visit 27) Warning (Form): For the best data quality, it is strongly recommended that the maximum number of allowed FP-POS positions is used when observing at a given COS CENWAVE setting. See full description for details. (Visit 27) Warning (Orbit Planner): ORBITAL VISIBILITY OVERRUN									
Diagnosics										
Fixed Targets	#	Name	Target Coordinates	Targ. Coord. Corrections	Fluxes	Miscellaneous				
	(27)	HD64184	RA: 07 49 26.6500 (117.3610417d) Dec: -59 22 51.04 (-59.38084d) Equinox: J2000	Proper Motion RA: 305.65 mas/yr Proper Motion Dec: -218.60 mas/yr Parallax: 0.03001" Epoch of Position: 2000 Radial Velocity: 0.0 km/sec	V=7.52+/-0.1 sptyp= G3V; (B-V)= 0.67 mag; dist= 33 pc	Reference Frame: ICRS				
Comments: Category=STAR Description=[G V-IV] Extended=NO										
Exposures	#	Label (ETC Run)	Target	Config,Mode,Aperture	Spectral Els.	Opt. Params.	Special Reqs.	Groups	Exp. Time (Total)/[Actual Dur.]	Orbit
	1	(COS.ta.100 4294)	(27) HD64184	COS/NUV, ACQ/IMAGE, BOA	MIRRORA				6 Secs (6 Secs) [==>]	[1]
2	(COS.sp.100 5139)	(27) HD64184	COS/FUV, TIME-TAG, PSA	G130M 1222 A	BUFFER-TIME=48 4; FP-POS=3			584 Secs (584 Secs) [==>]	[1]	
Comments: Note: ETC simulation (for G130M-1291, so as to include Ly-alpha) is for an "extreme" FUV spectrum, scaled to V=7.2 mag, and thus will over-predict count rates for most of the targets (see Observation Description).										
3	(COS.sp.100 5139)	(27) HD64184	COS/FUV, TIME-TAG, PSA	G130M 1222 A	BUFFER-TIME=48 4; FP-POS=4			584 Secs (584 Secs) [==>]	[1]	
Comments: Note: ETC simulation (for G130M-1291, so as to include Ly-alpha) is for an "extreme" FUV spectrum, scaled to V=7.2 mag, and thus will over-predict count rates for most of the targets (see Observation Description).										
4	(COS.sp.100 5139)	(27) HD64184	COS/FUV, TIME-TAG, PSA	G130M 1291 A	BUFFER-TIME=48 4; FP-POS=3			584 Secs (584 Secs) [==>]	[1]	
Comments: Note: ETC simulation (for G130M-1291, so as to include Ly-alpha) is for an "extreme" FUV spectrum, scaled to V=7.2 mag, and thus will over-predict count rates for most of the targets (see Observation Description).										
5	(COS.sp.100 5139)	(27) HD64184	COS/FUV, TIME-TAG, PSA	G130M 1291 A	BUFFER-TIME=48 4; FP-POS=4			584 Secs (584 Secs) [==>]	[1]	
Comments: Note: ETC simulation (for G130M-1291, so as to include Ly-alpha) is for an "extreme" FUV spectrum, scaled to V=7.2 mag, and thus will over-predict count rates for most of the targets (see Observation Description).										

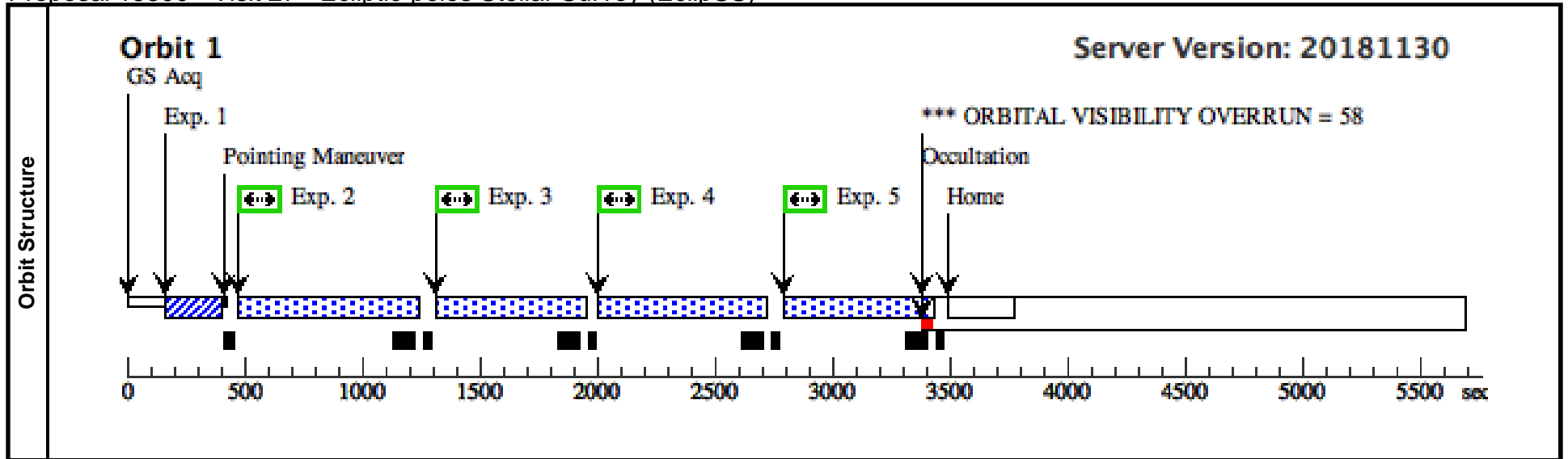

Proposal 15300 - Visit 28 - Ecliptic-poles Stellar Survey (EclipSS)

Thu Dec 13 22:02:08 GMT 2018

Visit	Proposal 15300, Visit 28, completed Diagnostic Status: Warning Scientific Instruments: COS/FUV, COS/NUV Special Requirements: (none)																																																																																																									
	(Visit 28) Warning (Form): For the best data quality, it is strongly recommended that the maximum number of allowed FP-POS positions is used when observing at a given COS CENWAVE setting. See full description for details. (Visit 28) Warning (Orbit Planner): ORBITAL VISIBILITY OVERRUN																																																																																																									
Diagnosics																																																																																																										
Fixed Targets	<table border="1"> <thead> <tr> <th>#</th> <th>Name</th> <th>Target Coordinates</th> <th>Targ. Coord. Corrections</th> <th>Fluxes</th> <th>Miscellaneous</th> </tr> </thead> <tbody> <tr> <td>(28)</td> <td>HD73744</td> <td>RA: 08 32 15.5614 (128.0648392d) Dec: -76 55 43.68 (-76.92880d) Equinox: J2000</td> <td>Proper Motion RA: -185.26 mas/yr Proper Motion Dec: 154.98 mas/yr Parallax: 0.02657" Epoch of Position: 2000 Radial Velocity: 0.0 km/sec</td> <td>V=7.61+/-0.1 sptyp= G5V; (B-V)= 0.60 mag; dist= 35 pc</td> <td>Reference Frame: ICRS</td> </tr> </tbody> </table>	#	Name	Target Coordinates	Targ. Coord. Corrections	Fluxes	Miscellaneous	(28)	HD73744	RA: 08 32 15.5614 (128.0648392d) Dec: -76 55 43.68 (-76.92880d) Equinox: J2000	Proper Motion RA: -185.26 mas/yr Proper Motion Dec: 154.98 mas/yr Parallax: 0.02657" Epoch of Position: 2000 Radial Velocity: 0.0 km/sec	V=7.61+/-0.1 sptyp= G5V; (B-V)= 0.60 mag; dist= 35 pc	Reference Frame: ICRS	Comments: Category=STAR Description=[G V-IV] Extended=NO																																																																																												
	#	Name	Target Coordinates	Targ. Coord. Corrections	Fluxes	Miscellaneous																																																																																																				
(28)	HD73744	RA: 08 32 15.5614 (128.0648392d) Dec: -76 55 43.68 (-76.92880d) Equinox: J2000	Proper Motion RA: -185.26 mas/yr Proper Motion Dec: 154.98 mas/yr Parallax: 0.02657" Epoch of Position: 2000 Radial Velocity: 0.0 km/sec	V=7.61+/-0.1 sptyp= G5V; (B-V)= 0.60 mag; dist= 35 pc	Reference Frame: ICRS																																																																																																					
Exposures	<table border="1"> <thead> <tr> <th>#</th> <th>Label (ETC Run)</th> <th>Target</th> <th>Config,Mode,Aperture</th> <th>Spectral Els.</th> <th>Opt. Params.</th> <th>Special Reqs.</th> <th>Groups</th> <th>Exp. Time (Total)/[Actual Dur.]</th> <th>Orbit</th> </tr> </thead> <tbody> <tr> <td>1</td> <td>(COS.ta.100 4296)</td> <td>(28) HD73744</td> <td>COS/NUV, ACQ/IMAGE, BOA</td> <td>MIRRORA</td> <td></td> <td></td> <td></td> <td>7 Secs (7 Secs) [==>]</td> <td>[1]</td> </tr> <tr> <td>2</td> <td>(COS.sp.100 5139)</td> <td>(28) HD73744</td> <td>COS/FUV, TIME-TAG, PSA</td> <td>G130M 1222 A</td> <td>BUFFER-TIME=51 6; FP-POS=3</td> <td></td> <td></td> <td>616 Secs (616 Secs) [==>]</td> <td>[1]</td> </tr> <tr> <td colspan="10"> Comments: Note: ETC simulation (for G130M-1291, so as to include Ly-alpha) is for an "extreme" FUV spectrum, scaled to V=7.2 mag, and thus will over-predict count rates for most of the targets (see Observation Description). </td> </tr> <tr> <td>3</td> <td>(COS.sp.100 5139)</td> <td>(28) HD73744</td> <td>COS/FUV, TIME-TAG, PSA</td> <td>G130M 1222 A</td> <td>BUFFER-TIME=51 6; FP-POS=4</td> <td></td> <td></td> <td>616 Secs (616 Secs) [==>]</td> <td>[1]</td> </tr> <tr> <td colspan="10"> Comments: Note: ETC simulation (for G130M-1291, so as to include Ly-alpha) is for an "extreme" FUV spectrum, scaled to V=7.2 mag, and thus will over-predict count rates for most of the targets (see Observation Description). </td> </tr> <tr> <td>4</td> <td>(COS.sp.100 5139)</td> <td>(28) HD73744</td> <td>COS/FUV, TIME-TAG, PSA</td> <td>G130M 1291 A</td> <td>BUFFER-TIME=51 6; FP-POS=3</td> <td></td> <td></td> <td>616 Secs (616 Secs) [==>]</td> <td>[1]</td> </tr> <tr> <td colspan="10"> Comments: Note: ETC simulation (for G130M-1291, so as to include Ly-alpha) is for an "extreme" FUV spectrum, scaled to V=7.2 mag, and thus will over-predict count rates for most of the targets (see Observation Description). </td> </tr> <tr> <td>5</td> <td>(COS.sp.100 5139)</td> <td>(28) HD73744</td> <td>COS/FUV, TIME-TAG, PSA</td> <td>G130M 1291 A</td> <td>BUFFER-TIME=51 6; FP-POS=4</td> <td></td> <td></td> <td>616 Secs (616 Secs) [==>]</td> <td>[1]</td> </tr> <tr> <td colspan="10"> Comments: Note: ETC simulation (for G130M-1291, so as to include Ly-alpha) is for an "extreme" FUV spectrum, scaled to V=7.2 mag, and thus will over-predict count rates for most of the targets (see Observation Description). </td> </tr> </tbody> </table>	#	Label (ETC Run)	Target	Config,Mode,Aperture	Spectral Els.	Opt. Params.	Special Reqs.	Groups	Exp. Time (Total)/[Actual Dur.]	Orbit	1	(COS.ta.100 4296)	(28) HD73744	COS/NUV, ACQ/IMAGE, BOA	MIRRORA				7 Secs (7 Secs) [==>]	[1]	2	(COS.sp.100 5139)	(28) HD73744	COS/FUV, TIME-TAG, PSA	G130M 1222 A	BUFFER-TIME=51 6; FP-POS=3			616 Secs (616 Secs) [==>]	[1]	Comments: Note: ETC simulation (for G130M-1291, so as to include Ly-alpha) is for an "extreme" FUV spectrum, scaled to V=7.2 mag, and thus will over-predict count rates for most of the targets (see Observation Description).										3	(COS.sp.100 5139)	(28) HD73744	COS/FUV, TIME-TAG, PSA	G130M 1222 A	BUFFER-TIME=51 6; FP-POS=4			616 Secs (616 Secs) [==>]	[1]	Comments: Note: ETC simulation (for G130M-1291, so as to include Ly-alpha) is for an "extreme" FUV spectrum, scaled to V=7.2 mag, and thus will over-predict count rates for most of the targets (see Observation Description).										4	(COS.sp.100 5139)	(28) HD73744	COS/FUV, TIME-TAG, PSA	G130M 1291 A	BUFFER-TIME=51 6; FP-POS=3			616 Secs (616 Secs) [==>]	[1]	Comments: Note: ETC simulation (for G130M-1291, so as to include Ly-alpha) is for an "extreme" FUV spectrum, scaled to V=7.2 mag, and thus will over-predict count rates for most of the targets (see Observation Description).										5	(COS.sp.100 5139)	(28) HD73744	COS/FUV, TIME-TAG, PSA	G130M 1291 A	BUFFER-TIME=51 6; FP-POS=4			616 Secs (616 Secs) [==>]	[1]	Comments: Note: ETC simulation (for G130M-1291, so as to include Ly-alpha) is for an "extreme" FUV spectrum, scaled to V=7.2 mag, and thus will over-predict count rates for most of the targets (see Observation Description).														
	#	Label (ETC Run)	Target	Config,Mode,Aperture	Spectral Els.	Opt. Params.	Special Reqs.	Groups	Exp. Time (Total)/[Actual Dur.]	Orbit																																																																																																
	1	(COS.ta.100 4296)	(28) HD73744	COS/NUV, ACQ/IMAGE, BOA	MIRRORA				7 Secs (7 Secs) [==>]	[1]																																																																																																
	2	(COS.sp.100 5139)	(28) HD73744	COS/FUV, TIME-TAG, PSA	G130M 1222 A	BUFFER-TIME=51 6; FP-POS=3			616 Secs (616 Secs) [==>]	[1]																																																																																																
	Comments: Note: ETC simulation (for G130M-1291, so as to include Ly-alpha) is for an "extreme" FUV spectrum, scaled to V=7.2 mag, and thus will over-predict count rates for most of the targets (see Observation Description).																																																																																																									
	3	(COS.sp.100 5139)	(28) HD73744	COS/FUV, TIME-TAG, PSA	G130M 1222 A	BUFFER-TIME=51 6; FP-POS=4			616 Secs (616 Secs) [==>]	[1]																																																																																																
Comments: Note: ETC simulation (for G130M-1291, so as to include Ly-alpha) is for an "extreme" FUV spectrum, scaled to V=7.2 mag, and thus will over-predict count rates for most of the targets (see Observation Description).																																																																																																										
4	(COS.sp.100 5139)	(28) HD73744	COS/FUV, TIME-TAG, PSA	G130M 1291 A	BUFFER-TIME=51 6; FP-POS=3			616 Secs (616 Secs) [==>]	[1]																																																																																																	
Comments: Note: ETC simulation (for G130M-1291, so as to include Ly-alpha) is for an "extreme" FUV spectrum, scaled to V=7.2 mag, and thus will over-predict count rates for most of the targets (see Observation Description).																																																																																																										
5	(COS.sp.100 5139)	(28) HD73744	COS/FUV, TIME-TAG, PSA	G130M 1291 A	BUFFER-TIME=51 6; FP-POS=4			616 Secs (616 Secs) [==>]	[1]																																																																																																	
Comments: Note: ETC simulation (for G130M-1291, so as to include Ly-alpha) is for an "extreme" FUV spectrum, scaled to V=7.2 mag, and thus will over-predict count rates for most of the targets (see Observation Description).																																																																																																										

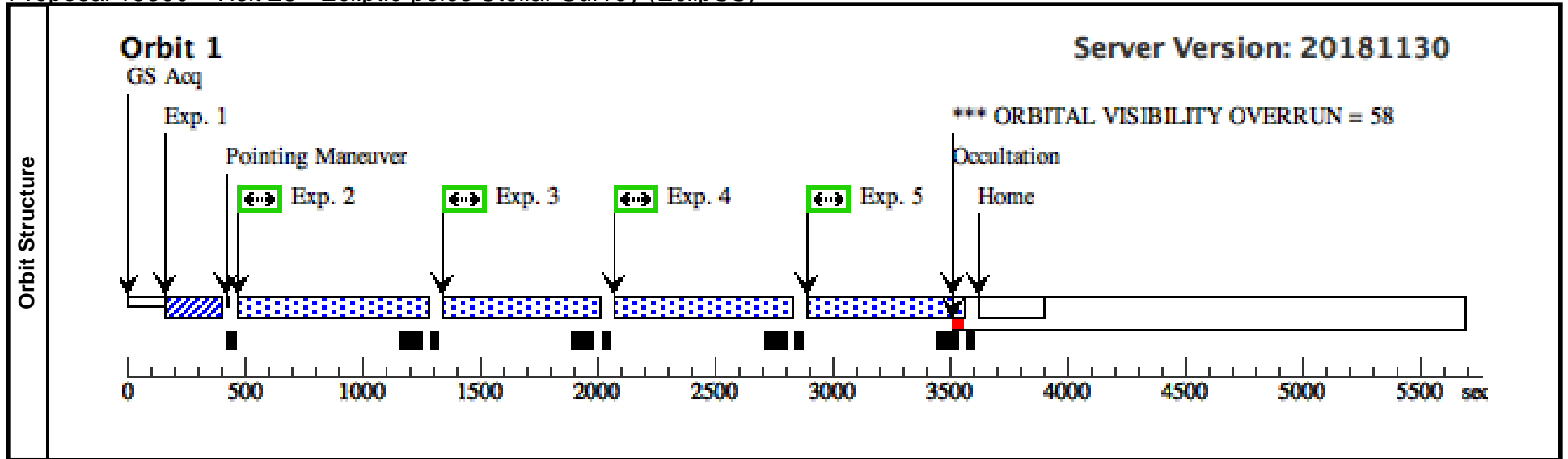

Proposal 15300 - Visit 29 - Ecliptic-poles Stellar Survey (EclipSS)

Thu Dec 13 22:02:08 GMT 2018

Visit	Proposal 15300, Visit 29, completed Diagnostic Status: Warning Scientific Instruments: COS/FUV, COS/NUV Special Requirements: (none)										
	(Visit 29) Warning (Form): For the best data quality, it is strongly recommended that the maximum number of allowed FP-POS positions is used when observing at a given COS CENWAVE setting. See full description for details. (Visit 29) Warning (Orbit Planner): ORBITAL VISIBILITY OVERRUN										
Fixed Targets	#	Name	Target Coordinates	Targ. Coord. Corrections	Fluxes	Miscellaneous					
	(29)	HD147231	RA: 16 14 50.2481 (243.7093671d) Dec: +70 55 46.79 (70.92966d) Equinox: J2000	Proper Motion RA: -2.35 mas/yr Proper Motion Dec: -286.25 mas/yr Parallax: 0.02511" Epoch of Position: 2000 Radial Velocity: 0.0 km/sec	V=7.90+/-0.1 sptyp= G5V; (B-V)= 0.63 mag; dist= 41 pc	Reference Frame: ICRS					
Comments: Category=STAR Description=[G V-IV] Extended=NO											
Exposures	#	Label (ETC Run)	Target	Config,Mode,Aperture	Spectral Els.	Opt. Params.	Special Reqs.	Groups	Exp. Time (Total)/[Actual Dur.]	Orbit	
	1	(COS.ta.100 4297)	(29) HD147231	COS/NUV, ACQ/IMAGE, BOA	MIRRORA				8 Secs (8 Secs) [==>]	[1]	
	2	(COS.sp.100 5139)	(29) HD147231	COS/FUV, TIME-TAG, PSA	G130M 1222 A	BUFFER-TIME=51 7; FP-POS=3			617 Secs (617 Secs) [==>]	[1]	
	Comments: Note: ETC simulation (for G130M-1291, so as to include Ly-alpha) is for an "extreme" FUV spectrum, scaled to V=7.2 mag, and thus will over-predict count rates for most of the targets (see Observation Description).										
	3	(COS.sp.100 5139)	(29) HD147231	COS/FUV, TIME-TAG, PSA	G130M 1222 A	BUFFER-TIME=51 7; FP-POS=4			617 Secs (617 Secs) [==>]	[1]	
	Comments: Note: ETC simulation (for G130M-1291, so as to include Ly-alpha) is for an "extreme" FUV spectrum, scaled to V=7.2 mag, and thus will over-predict count rates for most of the targets (see Observation Description).										
4	(COS.sp.100 5139)	(29) HD147231	COS/FUV, TIME-TAG, PSA	G130M 1291 A	BUFFER-TIME=51 7; FP-POS=3			617 Secs (617 Secs) [==>]	[1]		
Comments: Note: ETC simulation (for G130M-1291, so as to include Ly-alpha) is for an "extreme" FUV spectrum, scaled to V=7.2 mag, and thus will over-predict count rates for most of the targets (see Observation Description).											
5	(COS.sp.100 5139)	(29) HD147231	COS/FUV, TIME-TAG, PSA	G130M 1291 A	BUFFER-TIME=51 7; FP-POS=4			617 Secs (617 Secs) [==>]	[1]		
Comments: Note: ETC simulation (for G130M-1291, so as to include Ly-alpha) is for an "extreme" FUV spectrum, scaled to V=7.2 mag, and thus will over-predict count rates for most of the targets (see Observation Description).											

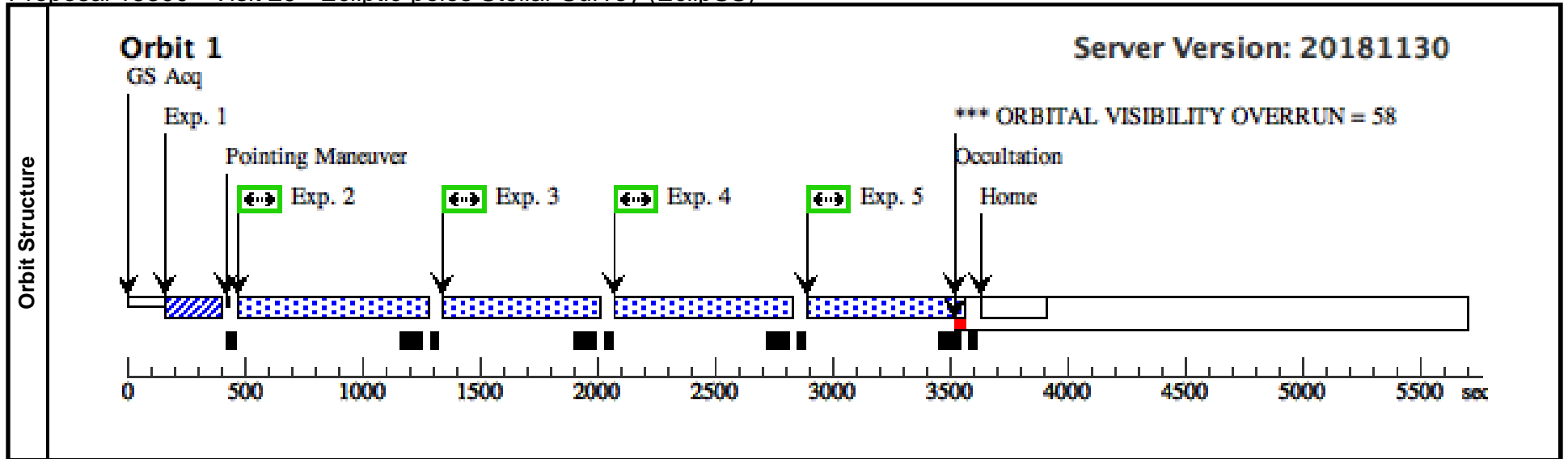

Proposal 15300 - Visit 30 - Ecliptic-poles Stellar Survey (EclipSS)

Thu Dec 13 22:02:08 GMT 2018

Visit	Proposal 15300, Visit 30, failed Diagnostic Status: Warning Scientific Instruments: COS/FUV, COS/NUV Special Requirements: (none)									
	(Visit 30) Warning (Form): For the best data quality, it is strongly recommended that the maximum number of allowed FP-POS positions is used when observing at a given COS CENWAVE setting. See full description for details. (Visit 30) Warning (Orbit Planner): ORBITAL VISIBILITY OVERRUN									
Diagnosics										
Fixed Targets	#	Name	Target Coordinates	Targ. Coord. Corrections	Fluxes	Miscellaneous				
	(30)	HD28471	RA: 04 25 9.1515 (66.2881313d) Dec: -64 04 48.25 (-64.08007d) Equinox: J2000	Proper Motion RA: -61.21 mas/yr Proper Motion Dec: 321.65 mas/yr Parallax: 0.2348" Epoch of Position: 2000 Radial Velocity: 0.0 km/sec	V=7.91+/-0.1 sptyp= G5V; (B-V)= 0.65 mag; dist= 44 pc	Reference Frame: ICRS				
Comments: Category=STAR Description=[G V-IV] Extended=NO										
Exposures	#	Label (ETC Run)	Target	Config,Mode,Aperture	Spectral Els.	Opt. Params.	Special Reqs.	Groups	Exp. Time (Total)/[Actual Dur.]	Orbit
	1	(COS.ta.100 4297)	(30) HD28471	COS/NUV, ACQ/IMAGE, BOA	MIRRORA				7 Secs (7 Secs) [==>]	[1]
2	(COS.sp.100 5139)	(30) HD28471	COS/FUV, TIME-TAG, PSA	G130M 1222 A	9; FP-POS=3			589 Secs (589 Secs) [==>]	[1]	
Comments: Note: ETC simulation (for G130M-1291, so as to include Ly-alpha) is for an "extreme" FUV spectrum, scaled to V=7.2 mag, and thus will over-predict count rates for most of the targets (see Observation Description).										
3	(COS.sp.100 5139)	(30) HD28471	COS/FUV, TIME-TAG, PSA	G130M 1222 A	9; FP-POS=4			589 Secs (589 Secs) [==>]	[1]	
Comments: Note: ETC simulation (for G130M-1291, so as to include Ly-alpha) is for an "extreme" FUV spectrum, scaled to V=7.2 mag, and thus will over-predict count rates for most of the targets (see Observation Description).										
4	(COS.sp.100 5139)	(30) HD28471	COS/FUV, TIME-TAG, PSA	G130M 1291 A	9; FP-POS=3			589 Secs (589 Secs) [==>]	[1]	
Comments: Note: ETC simulation (for G130M-1291, so as to include Ly-alpha) is for an "extreme" FUV spectrum, scaled to V=7.2 mag, and thus will over-predict count rates for most of the targets (see Observation Description).										
5	(COS.sp.100 5139)	(30) HD28471	COS/FUV, TIME-TAG, PSA	G130M 1291 A	9; FP-POS=4			589 Secs (589 Secs) [==>]	[1]	
Comments: Note: ETC simulation (for G130M-1291, so as to include Ly-alpha) is for an "extreme" FUV spectrum, scaled to V=7.2 mag, and thus will over-predict count rates for most of the targets (see Observation Description).										

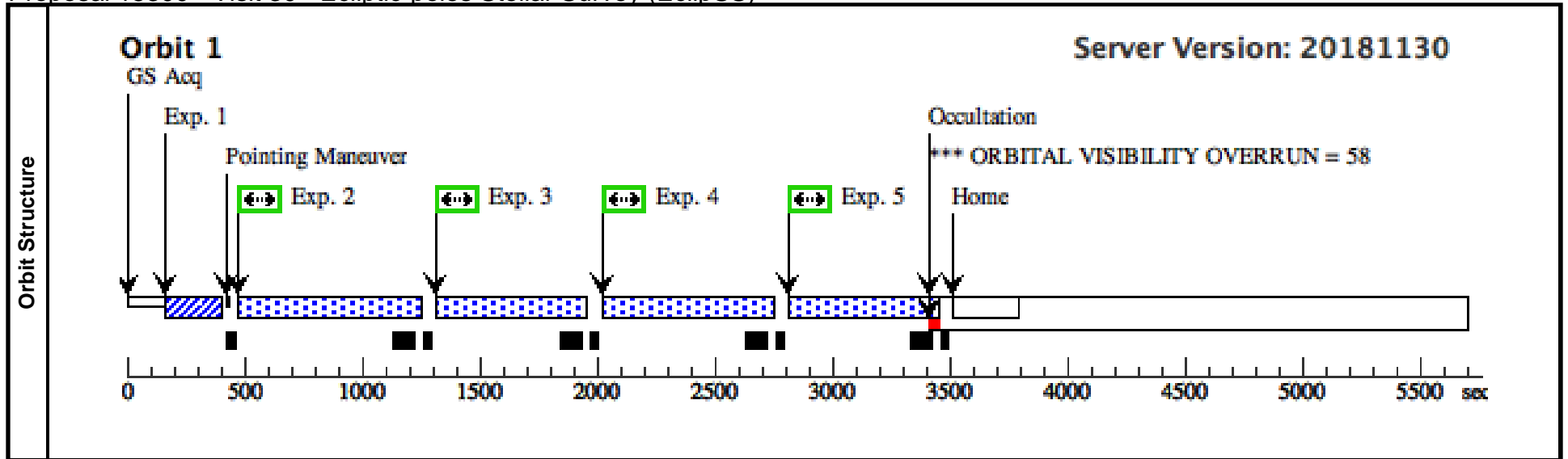

Proposal 15300 - Visit 31 - Ecliptic-poles Stellar Survey (EclipSS)

Thu Dec 13 22:02:08 GMT 2018

Visit	Proposal 15300, Visit 31, scheduling Diagnostic Status: Warning Scientific Instruments: COS/FUV, COS/NUV Special Requirements: ORIENT 139D TO 199 D; ORIENT 319D TO 359.00 D; ORIENT 0.0D TO 19 D <i>Comments: AB 2.3" PA=34 dV=5.0; ORIENT to keep faint secondary away from primary spectrum</i>																																																																																																									
	(Visit 31) Warning (Form): For the best data quality, it is strongly recommended that the maximum number of allowed FP-POS positions is used when observing at a given COS CENWAVE setting. See full description for details. (Visit 31) Warning (Orbit Planner): ORBITAL VISIBILITY OVERRUN																																																																																																									
Diagnosics																																																																																																										
Fixed Targets	<table border="1"> <thead> <tr> <th>#</th> <th>Name</th> <th>Target Coordinates</th> <th>Targ. Coord. Corrections</th> <th>Fluxes</th> <th>Miscellaneous</th> </tr> </thead> <tbody> <tr> <td>(31)</td> <td>HD144061</td> <td>RA: 15 58 21.0278 (239.5876158d) Dec: +70 53 40.00 (70.89444d) Equinox: J2000</td> <td>Proper Motion RA: -59.02 mas/yr Proper Motion Dec: 253.73 mas/yr Parallax: 0.03379" Epoch of Position: 2000 Radial Velocity: 0.0 km/sec</td> <td>V=7.29+/-0.1 sptyp= G5V; (B-V)= 0.66 mag; dist= 29 pc</td> <td>Reference Frame: ICRS</td> </tr> </tbody> </table>	#	Name	Target Coordinates	Targ. Coord. Corrections	Fluxes	Miscellaneous	(31)	HD144061	RA: 15 58 21.0278 (239.5876158d) Dec: +70 53 40.00 (70.89444d) Equinox: J2000	Proper Motion RA: -59.02 mas/yr Proper Motion Dec: 253.73 mas/yr Parallax: 0.03379" Epoch of Position: 2000 Radial Velocity: 0.0 km/sec	V=7.29+/-0.1 sptyp= G5V; (B-V)= 0.66 mag; dist= 29 pc	Reference Frame: ICRS	<i>Comments:</i> Category=STAR Description=[G V-IV] Extended=NO																																																																																												
	#	Name	Target Coordinates	Targ. Coord. Corrections	Fluxes	Miscellaneous																																																																																																				
(31)	HD144061	RA: 15 58 21.0278 (239.5876158d) Dec: +70 53 40.00 (70.89444d) Equinox: J2000	Proper Motion RA: -59.02 mas/yr Proper Motion Dec: 253.73 mas/yr Parallax: 0.03379" Epoch of Position: 2000 Radial Velocity: 0.0 km/sec	V=7.29+/-0.1 sptyp= G5V; (B-V)= 0.66 mag; dist= 29 pc	Reference Frame: ICRS																																																																																																					
Exposures	<table border="1"> <thead> <tr> <th>#</th> <th>Label (ETC Run)</th> <th>Target</th> <th>Config,Mode,Aperture</th> <th>Spectral Els.</th> <th>Opt. Params.</th> <th>Special Reqs.</th> <th>Groups</th> <th>Exp. Time (Total)/[Actual Dur.]</th> <th>Orbit</th> </tr> </thead> <tbody> <tr> <td>1</td> <td>(COS.ta.100 4298)</td> <td>(31) HD144061</td> <td>COS/NUV, ACQ/IMAGE, BOA</td> <td>MIRRORA</td> <td></td> <td></td> <td></td> <td>6 Secs (6 Secs) [==>]</td> <td>[1]</td> </tr> <tr> <td>2</td> <td>(COS.sp.100 5139)</td> <td>(31) HD144061</td> <td>COS/FUV, TIME-TAG, PSA</td> <td>G130M 1222 A</td> <td>BUFFER-TIME=51 8; FP-POS=3</td> <td></td> <td></td> <td>618 Secs (618 Secs) [==>]</td> <td>[1]</td> </tr> <tr> <td colspan="10"><i>Comments: Note: ETC simulation (for G130M-1291, so as to include Ly-alpha) is for an "extreme" FUV spectrum, scaled to V=7.2 mag, and thus will over-predict count rates for most of the targets (see Observation Description).</i></td> </tr> <tr> <td>3</td> <td>(COS.sp.100 5139)</td> <td>(31) HD144061</td> <td>COS/FUV, TIME-TAG, PSA</td> <td>G130M 1222 A</td> <td>BUFFER-TIME=51 8; FP-POS=4</td> <td></td> <td></td> <td>618 Secs (618 Secs) [==>]</td> <td>[1]</td> </tr> <tr> <td colspan="10"><i>Comments: Note: ETC simulation (for G130M-1291, so as to include Ly-alpha) is for an "extreme" FUV spectrum, scaled to V=7.2 mag, and thus will over-predict count rates for most of the targets (see Observation Description).</i></td> </tr> <tr> <td>4</td> <td>(COS.sp.100 5139)</td> <td>(31) HD144061</td> <td>COS/FUV, TIME-TAG, PSA</td> <td>G130M 1291 A</td> <td>BUFFER-TIME=51 8; FP-POS=3</td> <td></td> <td></td> <td>618 Secs (618 Secs) [==>]</td> <td>[1]</td> </tr> <tr> <td colspan="10"><i>Comments: Note: ETC simulation (for G130M-1291, so as to include Ly-alpha) is for an "extreme" FUV spectrum, scaled to V=7.2 mag, and thus will over-predict count rates for most of the targets (see Observation Description).</i></td> </tr> <tr> <td>5</td> <td>(COS.sp.100 5139)</td> <td>(31) HD144061</td> <td>COS/FUV, TIME-TAG, PSA</td> <td>G130M 1291 A</td> <td>BUFFER-TIME=51 8; FP-POS=4</td> <td></td> <td></td> <td>618 Secs (618 Secs) [==>]</td> <td>[1]</td> </tr> <tr> <td colspan="10"><i>Comments: Note: ETC simulation (for G130M-1291, so as to include Ly-alpha) is for an "extreme" FUV spectrum, scaled to V=7.2 mag, and thus will over-predict count rates for most of the targets (see Observation Description).</i></td> </tr> </tbody> </table>	#	Label (ETC Run)	Target	Config,Mode,Aperture	Spectral Els.	Opt. Params.	Special Reqs.	Groups	Exp. Time (Total)/[Actual Dur.]	Orbit	1	(COS.ta.100 4298)	(31) HD144061	COS/NUV, ACQ/IMAGE, BOA	MIRRORA				6 Secs (6 Secs) [==>]	[1]	2	(COS.sp.100 5139)	(31) HD144061	COS/FUV, TIME-TAG, PSA	G130M 1222 A	BUFFER-TIME=51 8; FP-POS=3			618 Secs (618 Secs) [==>]	[1]	<i>Comments: Note: ETC simulation (for G130M-1291, so as to include Ly-alpha) is for an "extreme" FUV spectrum, scaled to V=7.2 mag, and thus will over-predict count rates for most of the targets (see Observation Description).</i>										3	(COS.sp.100 5139)	(31) HD144061	COS/FUV, TIME-TAG, PSA	G130M 1222 A	BUFFER-TIME=51 8; FP-POS=4			618 Secs (618 Secs) [==>]	[1]	<i>Comments: Note: ETC simulation (for G130M-1291, so as to include Ly-alpha) is for an "extreme" FUV spectrum, scaled to V=7.2 mag, and thus will over-predict count rates for most of the targets (see Observation Description).</i>										4	(COS.sp.100 5139)	(31) HD144061	COS/FUV, TIME-TAG, PSA	G130M 1291 A	BUFFER-TIME=51 8; FP-POS=3			618 Secs (618 Secs) [==>]	[1]	<i>Comments: Note: ETC simulation (for G130M-1291, so as to include Ly-alpha) is for an "extreme" FUV spectrum, scaled to V=7.2 mag, and thus will over-predict count rates for most of the targets (see Observation Description).</i>										5	(COS.sp.100 5139)	(31) HD144061	COS/FUV, TIME-TAG, PSA	G130M 1291 A	BUFFER-TIME=51 8; FP-POS=4			618 Secs (618 Secs) [==>]	[1]	<i>Comments: Note: ETC simulation (for G130M-1291, so as to include Ly-alpha) is for an "extreme" FUV spectrum, scaled to V=7.2 mag, and thus will over-predict count rates for most of the targets (see Observation Description).</i>														
	#	Label (ETC Run)	Target	Config,Mode,Aperture	Spectral Els.	Opt. Params.	Special Reqs.	Groups	Exp. Time (Total)/[Actual Dur.]	Orbit																																																																																																
	1	(COS.ta.100 4298)	(31) HD144061	COS/NUV, ACQ/IMAGE, BOA	MIRRORA				6 Secs (6 Secs) [==>]	[1]																																																																																																
	2	(COS.sp.100 5139)	(31) HD144061	COS/FUV, TIME-TAG, PSA	G130M 1222 A	BUFFER-TIME=51 8; FP-POS=3			618 Secs (618 Secs) [==>]	[1]																																																																																																
	<i>Comments: Note: ETC simulation (for G130M-1291, so as to include Ly-alpha) is for an "extreme" FUV spectrum, scaled to V=7.2 mag, and thus will over-predict count rates for most of the targets (see Observation Description).</i>																																																																																																									
	3	(COS.sp.100 5139)	(31) HD144061	COS/FUV, TIME-TAG, PSA	G130M 1222 A	BUFFER-TIME=51 8; FP-POS=4			618 Secs (618 Secs) [==>]	[1]																																																																																																
<i>Comments: Note: ETC simulation (for G130M-1291, so as to include Ly-alpha) is for an "extreme" FUV spectrum, scaled to V=7.2 mag, and thus will over-predict count rates for most of the targets (see Observation Description).</i>																																																																																																										
4	(COS.sp.100 5139)	(31) HD144061	COS/FUV, TIME-TAG, PSA	G130M 1291 A	BUFFER-TIME=51 8; FP-POS=3			618 Secs (618 Secs) [==>]	[1]																																																																																																	
<i>Comments: Note: ETC simulation (for G130M-1291, so as to include Ly-alpha) is for an "extreme" FUV spectrum, scaled to V=7.2 mag, and thus will over-predict count rates for most of the targets (see Observation Description).</i>																																																																																																										
5	(COS.sp.100 5139)	(31) HD144061	COS/FUV, TIME-TAG, PSA	G130M 1291 A	BUFFER-TIME=51 8; FP-POS=4			618 Secs (618 Secs) [==>]	[1]																																																																																																	
<i>Comments: Note: ETC simulation (for G130M-1291, so as to include Ly-alpha) is for an "extreme" FUV spectrum, scaled to V=7.2 mag, and thus will over-predict count rates for most of the targets (see Observation Description).</i>																																																																																																										

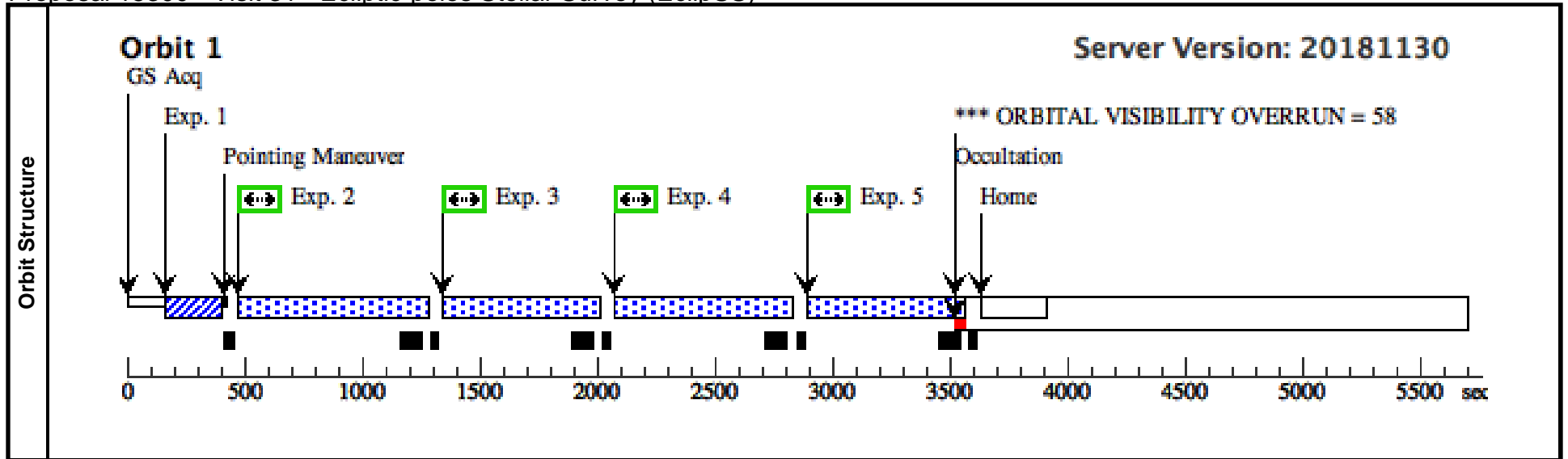

Proposal 15300 - Visit 32 - Ecliptic-poles Stellar Survey (EclipSS)

Thu Dec 13 22:02:08 GMT 2018

Visit	Proposal 15300, Visit 32, scheduled Diagnostic Status: Warning Scientific Instruments: COS/FUV, COS/NUV Special Requirements: (none)																																																																																																									
	(Visit 32) Warning (Form): For the best data quality, it is strongly recommended that the maximum number of allowed FP-POS positions is used when observing at a given COS CENWAVE setting. See full description for details. (Visit 32) Warning (Orbit Planner): ORBITAL VISIBILITY OVERRUN																																																																																																									
Diagnosics																																																																																																										
Fixed Targets	<table border="1"> <thead> <tr> <th>#</th> <th>Name</th> <th>Target Coordinates</th> <th>Targ. Coord. Corrections</th> <th>Fluxes</th> <th>Miscellaneous</th> </tr> </thead> <tbody> <tr> <td>(32)</td> <td>HD146868</td> <td>RA: 16 14 57.0782 (243.7378258d) Dec: +60 40 11.17 (60.66977d) Equinox: J2000</td> <td>Proper Motion RA: 25.16 mas/yr Proper Motion Dec: 437.47 mas/yr Parallax: 0.03254" Epoch of Position: 2000 Radial Velocity: 0.0 km/sec</td> <td>V=7.69+/-0.1 sptyp= G5V; (B-V)= 0.66 mag; dist= 30 pc</td> <td>Reference Frame: ICRS</td> </tr> </tbody> </table>	#	Name	Target Coordinates	Targ. Coord. Corrections	Fluxes	Miscellaneous	(32)	HD146868	RA: 16 14 57.0782 (243.7378258d) Dec: +60 40 11.17 (60.66977d) Equinox: J2000	Proper Motion RA: 25.16 mas/yr Proper Motion Dec: 437.47 mas/yr Parallax: 0.03254" Epoch of Position: 2000 Radial Velocity: 0.0 km/sec	V=7.69+/-0.1 sptyp= G5V; (B-V)= 0.66 mag; dist= 30 pc	Reference Frame: ICRS	Comments: Category=STAR Description=[G V-IV] Extended=NO																																																																																												
	#	Name	Target Coordinates	Targ. Coord. Corrections	Fluxes	Miscellaneous																																																																																																				
(32)	HD146868	RA: 16 14 57.0782 (243.7378258d) Dec: +60 40 11.17 (60.66977d) Equinox: J2000	Proper Motion RA: 25.16 mas/yr Proper Motion Dec: 437.47 mas/yr Parallax: 0.03254" Epoch of Position: 2000 Radial Velocity: 0.0 km/sec	V=7.69+/-0.1 sptyp= G5V; (B-V)= 0.66 mag; dist= 30 pc	Reference Frame: ICRS																																																																																																					
Exposures	<table border="1"> <thead> <tr> <th>#</th> <th>Label (ETC Run)</th> <th>Target</th> <th>Config,Mode,Aperture</th> <th>Spectral Els.</th> <th>Opt. Params.</th> <th>Special Reqs.</th> <th>Groups</th> <th>Exp. Time (Total)/[Actual Dur.]</th> <th>Orbit</th> </tr> </thead> <tbody> <tr> <td>1</td> <td>(COS.ta.100 4299)</td> <td>(32) HD146868</td> <td>COS/NUV, ACQ/IMAGE, BOA</td> <td>MIRRORA</td> <td></td> <td></td> <td></td> <td>7 Secs (7 Secs) [==>]</td> <td>[1]</td> </tr> <tr> <td>2</td> <td>(COS.sp.100 5139)</td> <td>(32) HD146868</td> <td>COS/FUV, TIME-TAG, PSA</td> <td>G130M 1222 A</td> <td>BUFFER-TIME=48 9; FP-POS=3</td> <td></td> <td></td> <td>589 Secs (589 Secs) [==>]</td> <td>[1]</td> </tr> <tr> <td colspan="10"> Comments: Note: ETC simulation (for G130M-1291, so as to include Ly-alpha) is for an "extreme" FUV spectrum, scaled to V=7.2 mag, and thus will over-predict count rates for most of the targets (see Observation Description). </td> </tr> <tr> <td>3</td> <td>(COS.sp.100 5139)</td> <td>(32) HD146868</td> <td>COS/FUV, TIME-TAG, PSA</td> <td>G130M 1222 A</td> <td>BUFFER-TIME=48 9; FP-POS=4</td> <td></td> <td></td> <td>589 Secs (589 Secs) [==>]</td> <td>[1]</td> </tr> <tr> <td colspan="10"> Comments: Note: ETC simulation (for G130M-1291, so as to include Ly-alpha) is for an "extreme" FUV spectrum, scaled to V=7.2 mag, and thus will over-predict count rates for most of the targets (see Observation Description). </td> </tr> <tr> <td>4</td> <td>(COS.sp.100 5139)</td> <td>(32) HD146868</td> <td>COS/FUV, TIME-TAG, PSA</td> <td>G130M 1291 A</td> <td>BUFFER-TIME=48 9; FP-POS=3</td> <td></td> <td></td> <td>589 Secs (589 Secs) [==>]</td> <td>[1]</td> </tr> <tr> <td colspan="10"> Comments: Note: ETC simulation (for G130M-1291, so as to include Ly-alpha) is for an "extreme" FUV spectrum, scaled to V=7.2 mag, and thus will over-predict count rates for most of the targets (see Observation Description). </td> </tr> <tr> <td>5</td> <td>(COS.sp.100 5139)</td> <td>(32) HD146868</td> <td>COS/FUV, TIME-TAG, PSA</td> <td>G130M 1291 A</td> <td>BUFFER-TIME=48 9; FP-POS=4</td> <td></td> <td></td> <td>589 Secs (589 Secs) [==>]</td> <td>[1]</td> </tr> <tr> <td colspan="10"> Comments: Note: ETC simulation (for G130M-1291, so as to include Ly-alpha) is for an "extreme" FUV spectrum, scaled to V=7.2 mag, and thus will over-predict count rates for most of the targets (see Observation Description). </td> </tr> </tbody> </table>	#	Label (ETC Run)	Target	Config,Mode,Aperture	Spectral Els.	Opt. Params.	Special Reqs.	Groups	Exp. Time (Total)/[Actual Dur.]	Orbit	1	(COS.ta.100 4299)	(32) HD146868	COS/NUV, ACQ/IMAGE, BOA	MIRRORA				7 Secs (7 Secs) [==>]	[1]	2	(COS.sp.100 5139)	(32) HD146868	COS/FUV, TIME-TAG, PSA	G130M 1222 A	BUFFER-TIME=48 9; FP-POS=3			589 Secs (589 Secs) [==>]	[1]	Comments: Note: ETC simulation (for G130M-1291, so as to include Ly-alpha) is for an "extreme" FUV spectrum, scaled to V=7.2 mag, and thus will over-predict count rates for most of the targets (see Observation Description).										3	(COS.sp.100 5139)	(32) HD146868	COS/FUV, TIME-TAG, PSA	G130M 1222 A	BUFFER-TIME=48 9; FP-POS=4			589 Secs (589 Secs) [==>]	[1]	Comments: Note: ETC simulation (for G130M-1291, so as to include Ly-alpha) is for an "extreme" FUV spectrum, scaled to V=7.2 mag, and thus will over-predict count rates for most of the targets (see Observation Description).										4	(COS.sp.100 5139)	(32) HD146868	COS/FUV, TIME-TAG, PSA	G130M 1291 A	BUFFER-TIME=48 9; FP-POS=3			589 Secs (589 Secs) [==>]	[1]	Comments: Note: ETC simulation (for G130M-1291, so as to include Ly-alpha) is for an "extreme" FUV spectrum, scaled to V=7.2 mag, and thus will over-predict count rates for most of the targets (see Observation Description).										5	(COS.sp.100 5139)	(32) HD146868	COS/FUV, TIME-TAG, PSA	G130M 1291 A	BUFFER-TIME=48 9; FP-POS=4			589 Secs (589 Secs) [==>]	[1]	Comments: Note: ETC simulation (for G130M-1291, so as to include Ly-alpha) is for an "extreme" FUV spectrum, scaled to V=7.2 mag, and thus will over-predict count rates for most of the targets (see Observation Description).														
	#	Label (ETC Run)	Target	Config,Mode,Aperture	Spectral Els.	Opt. Params.	Special Reqs.	Groups	Exp. Time (Total)/[Actual Dur.]	Orbit																																																																																																
	1	(COS.ta.100 4299)	(32) HD146868	COS/NUV, ACQ/IMAGE, BOA	MIRRORA				7 Secs (7 Secs) [==>]	[1]																																																																																																
	2	(COS.sp.100 5139)	(32) HD146868	COS/FUV, TIME-TAG, PSA	G130M 1222 A	BUFFER-TIME=48 9; FP-POS=3			589 Secs (589 Secs) [==>]	[1]																																																																																																
	Comments: Note: ETC simulation (for G130M-1291, so as to include Ly-alpha) is for an "extreme" FUV spectrum, scaled to V=7.2 mag, and thus will over-predict count rates for most of the targets (see Observation Description).																																																																																																									
	3	(COS.sp.100 5139)	(32) HD146868	COS/FUV, TIME-TAG, PSA	G130M 1222 A	BUFFER-TIME=48 9; FP-POS=4			589 Secs (589 Secs) [==>]	[1]																																																																																																
Comments: Note: ETC simulation (for G130M-1291, so as to include Ly-alpha) is for an "extreme" FUV spectrum, scaled to V=7.2 mag, and thus will over-predict count rates for most of the targets (see Observation Description).																																																																																																										
4	(COS.sp.100 5139)	(32) HD146868	COS/FUV, TIME-TAG, PSA	G130M 1291 A	BUFFER-TIME=48 9; FP-POS=3			589 Secs (589 Secs) [==>]	[1]																																																																																																	
Comments: Note: ETC simulation (for G130M-1291, so as to include Ly-alpha) is for an "extreme" FUV spectrum, scaled to V=7.2 mag, and thus will over-predict count rates for most of the targets (see Observation Description).																																																																																																										
5	(COS.sp.100 5139)	(32) HD146868	COS/FUV, TIME-TAG, PSA	G130M 1291 A	BUFFER-TIME=48 9; FP-POS=4			589 Secs (589 Secs) [==>]	[1]																																																																																																	
Comments: Note: ETC simulation (for G130M-1291, so as to include Ly-alpha) is for an "extreme" FUV spectrum, scaled to V=7.2 mag, and thus will over-predict count rates for most of the targets (see Observation Description).																																																																																																										

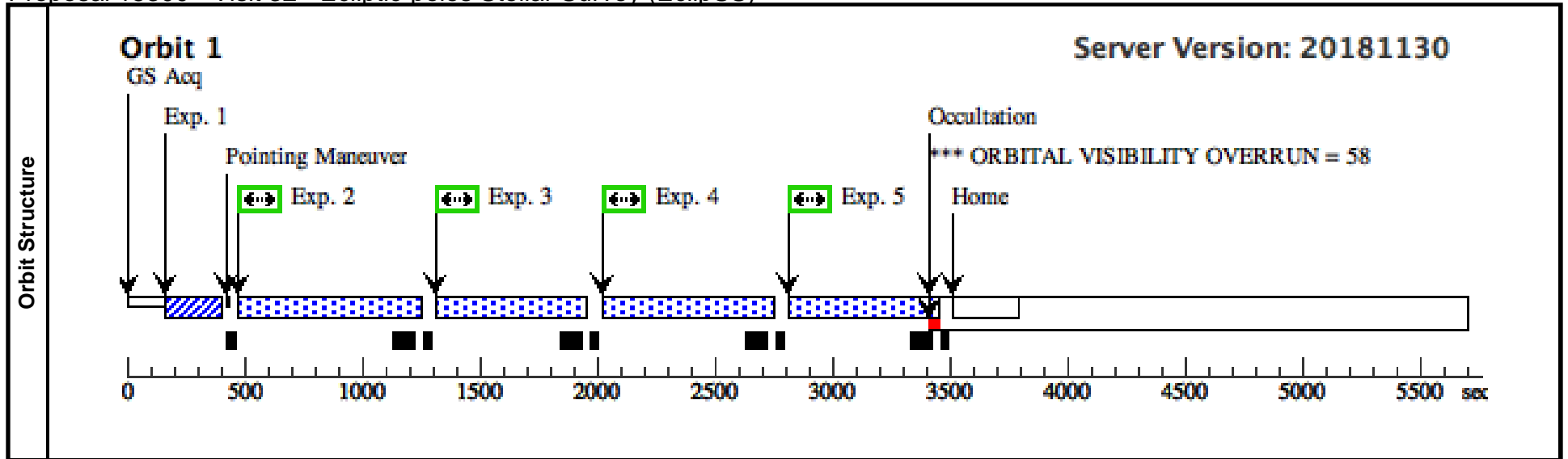

Proposal 15300 - Visit 33 - Ecliptic-poles Stellar Survey (EclipSS)

Thu Dec 13 22:02:08 GMT 2018

Visit	Proposal 15300, Visit 33, completed Diagnostic Status: Warning Scientific Instruments: COS/FUV, COS/NUV Special Requirements: (none)										
	(Visit 33) Warning (Form): For the best data quality, it is strongly recommended that the maximum number of allowed FP-POS positions is used when observing at a given COS CENWAVE setting. See full description for details. (Visit 33) Warning (Orbit Planner): ORBITAL VISIBILITY OVERRUN										
Fixed Targets	#	Name	Target Coordinates	Targ. Coord. Corrections	Fluxes	Miscellaneous					
	(33)	HD137826	RA: 15 24 4.9663 (231.0206929d) Dec: +66 33 14.13 (66.55392d) Equinox: J2000	Proper Motion RA: -265.09 mas/yr Proper Motion Dec: -31.73 mas/yr Parallax: 0.02043" Epoch of Position: 2000 Radial Velocity: 0.0 km/sec	V=8.72+/-0.1 sptyp= G6V; (B-V)= 0.69 mag; dist= 49 pc	Reference Frame: ICRS					
Comments: Category=STAR Description=[G V-IV] Extended=NO											
Exposures	#	Label (ETC Run)	Target	Config,Mode,Aperture	Spectral Els.	Opt. Params.	Special Reqs.	Groups	Exp. Time (Total)/[Actual Dur.]	Orbit	
	1	(COS.ta.100 4300)	(33) HD137826	COS/NUV, ACQ/IMAGE, BOA	MIRRORA				58 Secs (58 Secs) [==>]	[1]	
	2	(COS.sp.100 5139)	(33) HD137826	COS/FUV, TIME-TAG, PSA	G130M 1222 A	BUFFER-TIME=46 5; FP-POS=3			575 Secs (575 Secs) [==>]	[1]	
	Comments: Note: ETC simulation (for G130M-1291, so as to include Ly-alpha) is for an "extreme" FUV spectrum, scaled to V=7.2 mag, and thus will over-predict count rates for most of the targets (see Observation Description).										
	3	(COS.sp.100 5139)	(33) HD137826	COS/FUV, TIME-TAG, PSA	G130M 1222 A	BUFFER-TIME=46 5; FP-POS=4			575 Secs (575 Secs) [==>]	[1]	
	Comments: Note: ETC simulation (for G130M-1291, so as to include Ly-alpha) is for an "extreme" FUV spectrum, scaled to V=7.2 mag, and thus will over-predict count rates for most of the targets (see Observation Description).										
4	(COS.sp.100 5139)	(33) HD137826	COS/FUV, TIME-TAG, PSA	G130M 1291 A	BUFFER-TIME=46 5; FP-POS=3			575 Secs (575 Secs) [==>]	[1]		
Comments: Note: ETC simulation (for G130M-1291, so as to include Ly-alpha) is for an "extreme" FUV spectrum, scaled to V=7.2 mag, and thus will over-predict count rates for most of the targets (see Observation Description).											
5	(COS.sp.100 5139)	(33) HD137826	COS/FUV, TIME-TAG, PSA	G130M 1291 A	BUFFER-TIME=46 5; FP-POS=4			575 Secs (575 Secs) [==>]	[1]		
Comments: Note: ETC simulation (for G130M-1291, so as to include Ly-alpha) is for an "extreme" FUV spectrum, scaled to V=7.2 mag, and thus will over-predict count rates for most of the targets (see Observation Description).											

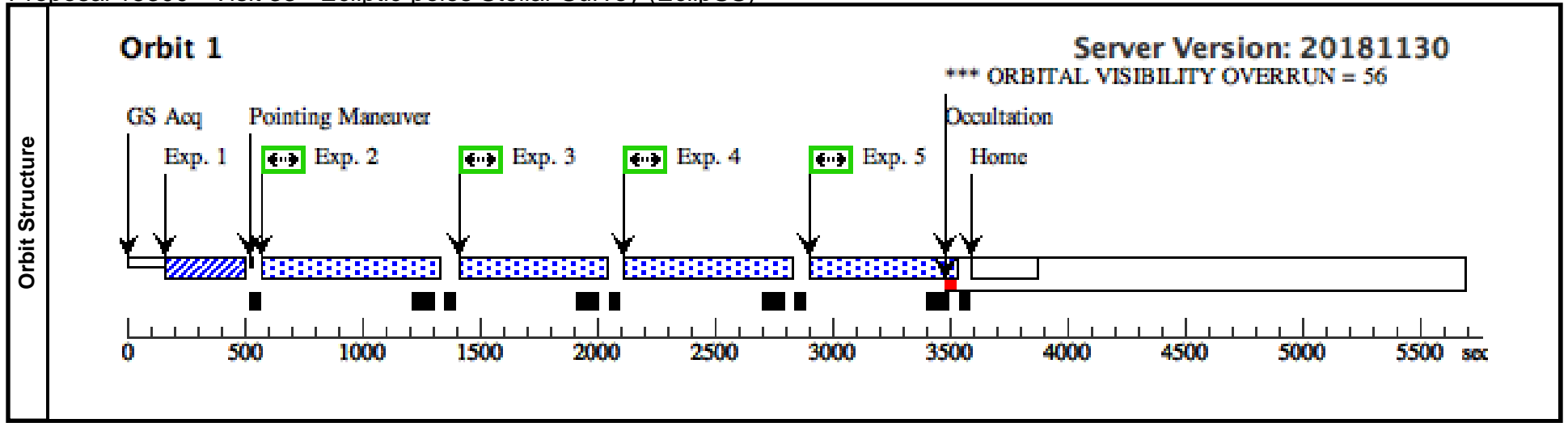

Proposal 15300 - Visit 34 - Ecliptic-poles Stellar Survey (EclipSS)

Thu Dec 13 22:02:08 GMT 2018

Visit	Proposal 15300, Visit 34, scheduled Diagnostic Status: Warning Scientific Instruments: COS/FUV, COS/NUV Special Requirements: (none)																																																																																																																			
	(Visit 34) Warning (Form): For the best data quality, it is strongly recommended that the maximum number of allowed FP-POS positions is used when observing at a given COS CENWAVE setting. See full description for details. (Visit 34) Warning (Orbit Planner): ORBITAL VISIBILITY OVERRUN																																																																																																																			
Fixed Targets	<table border="1"> <thead> <tr> <th>#</th> <th>Name</th> <th>Target Coordinates</th> <th>Targ. Coord. Corrections</th> <th>Fluxes</th> <th>Miscellaneous</th> </tr> </thead> <tbody> <tr> <td>(34)</td> <td>HD32778</td> <td>RA: 05 02 17.0598 (75.5710825d) Dec: -56 04 49.93 (-56.08054d) Equinox: J2000</td> <td>Proper Motion RA: -45.43 mas/yr Proper Motion Dec: 731.74 mas/yr Parallax: 0.04448" Epoch of Position: 2000 Radial Velocity: 0.0 km/sec</td> <td>V=7.02+/-0.1 sptyp= G7V; (B-V)= 0.63 mag; dist= 22 pc</td> <td>Reference Frame: ICRS</td> </tr> </tbody> </table>						#	Name	Target Coordinates	Targ. Coord. Corrections	Fluxes	Miscellaneous	(34)	HD32778	RA: 05 02 17.0598 (75.5710825d) Dec: -56 04 49.93 (-56.08054d) Equinox: J2000	Proper Motion RA: -45.43 mas/yr Proper Motion Dec: 731.74 mas/yr Parallax: 0.04448" Epoch of Position: 2000 Radial Velocity: 0.0 km/sec	V=7.02+/-0.1 sptyp= G7V; (B-V)= 0.63 mag; dist= 22 pc	Reference Frame: ICRS																																																																																																		
	#	Name	Target Coordinates	Targ. Coord. Corrections	Fluxes	Miscellaneous																																																																																																														
(34)	HD32778	RA: 05 02 17.0598 (75.5710825d) Dec: -56 04 49.93 (-56.08054d) Equinox: J2000	Proper Motion RA: -45.43 mas/yr Proper Motion Dec: 731.74 mas/yr Parallax: 0.04448" Epoch of Position: 2000 Radial Velocity: 0.0 km/sec	V=7.02+/-0.1 sptyp= G7V; (B-V)= 0.63 mag; dist= 22 pc	Reference Frame: ICRS																																																																																																															
Comments: Category=STAR Description=[G V-IV] Extended=NO																																																																																																																				
Exposures	<table border="1"> <thead> <tr> <th>#</th> <th>Label (ETC Run)</th> <th>Target</th> <th>Config,Mode,Aperture</th> <th>Spectral Els.</th> <th>Opt. Params.</th> <th>Special Reqs.</th> <th>Groups</th> <th>Exp. Time (Total)/[Actual Dur.]</th> <th>Orbit</th> </tr> </thead> <tbody> <tr> <td>1</td> <td>(COS.ta.129 9645)</td> <td>(34) HD32778</td> <td>COS/NUV, ACQ/IMAGE, BOA</td> <td>MIRRORB</td> <td></td> <td></td> <td></td> <td>45 Secs (45 Secs) [==>]</td> <td>[1]</td> </tr> <tr> <td colspan="10"> Comments: acquisition changed to MIRROR B (27 NOV 2018) to account for bluer color of target than expected for late-G spectral type; also compatible with the Galex NUV magnitude. ETC simulation done with Cas-Kur G2V model, V=+7.02. </td> </tr> <tr> <td>2</td> <td>(COS.sp.100 5139)</td> <td>(34) HD32778</td> <td>COS/FUV, TIME-TAG, PSA</td> <td>G130M 1222 A</td> <td>BUFFER-TIME=46 5; FP-POS=3</td> <td></td> <td></td> <td>565 Secs (565 Secs) [==>]</td> <td>[1]</td> </tr> <tr> <td colspan="10"> Comments: Note: ETC simulation (for G130M-1291, so as to include Ly-alpha) is for an "extreme" FUV spectrum, scaled to V=7.2 mag, and thus will over-predict count rates for most of the targets (see Observation Description). </td> </tr> <tr> <td>3</td> <td>(COS.sp.100 5139)</td> <td>(34) HD32778</td> <td>COS/FUV, TIME-TAG, PSA</td> <td>G130M 1222 A</td> <td>BUFFER-TIME=46 5; FP-POS=4</td> <td></td> <td></td> <td>565 Secs (565 Secs) [==>]</td> <td>[1]</td> </tr> <tr> <td colspan="10"> Comments: Note: ETC simulation (for G130M-1291, so as to include Ly-alpha) is for an "extreme" FUV spectrum, scaled to V=7.2 mag, and thus will over-predict count rates for most of the targets (see Observation Description). </td> </tr> <tr> <td>4</td> <td>(COS.sp.100 5139)</td> <td>(34) HD32778</td> <td>COS/FUV, TIME-TAG, PSA</td> <td>G130M 1291 A</td> <td>BUFFER-TIME=46 5; FP-POS=3</td> <td></td> <td></td> <td>565 Secs (565 Secs) [==>]</td> <td>[1]</td> </tr> <tr> <td colspan="10"> Comments: Note: ETC simulation (for G130M-1291, so as to include Ly-alpha) is for an "extreme" FUV spectrum, scaled to V=7.2 mag, and thus will over-predict count rates for most of the targets (see Observation Description). </td> </tr> <tr> <td>5</td> <td>(COS.sp.100 5139)</td> <td>(34) HD32778</td> <td>COS/FUV, TIME-TAG, PSA</td> <td>G130M 1291 A</td> <td>BUFFER-TIME=46 5; FP-POS=4</td> <td></td> <td></td> <td>565 Secs (565 Secs) [==>]</td> <td>[1]</td> </tr> <tr> <td colspan="10"> Comments: Note: ETC simulation (for G130M-1291, so as to include Ly-alpha) is for an "extreme" FUV spectrum, scaled to V=7.2 mag, and thus will over-predict count rates for most of the targets (see Observation Description). </td> </tr> </tbody> </table>						#	Label (ETC Run)	Target	Config,Mode,Aperture	Spectral Els.	Opt. Params.	Special Reqs.	Groups	Exp. Time (Total)/[Actual Dur.]	Orbit	1	(COS.ta.129 9645)	(34) HD32778	COS/NUV, ACQ/IMAGE, BOA	MIRRORB				45 Secs (45 Secs) [==>]	[1]	Comments: acquisition changed to MIRROR B (27 NOV 2018) to account for bluer color of target than expected for late-G spectral type; also compatible with the Galex NUV magnitude. ETC simulation done with Cas-Kur G2V model, V=+7.02.										2	(COS.sp.100 5139)	(34) HD32778	COS/FUV, TIME-TAG, PSA	G130M 1222 A	BUFFER-TIME=46 5; FP-POS=3			565 Secs (565 Secs) [==>]	[1]	Comments: Note: ETC simulation (for G130M-1291, so as to include Ly-alpha) is for an "extreme" FUV spectrum, scaled to V=7.2 mag, and thus will over-predict count rates for most of the targets (see Observation Description).										3	(COS.sp.100 5139)	(34) HD32778	COS/FUV, TIME-TAG, PSA	G130M 1222 A	BUFFER-TIME=46 5; FP-POS=4			565 Secs (565 Secs) [==>]	[1]	Comments: Note: ETC simulation (for G130M-1291, so as to include Ly-alpha) is for an "extreme" FUV spectrum, scaled to V=7.2 mag, and thus will over-predict count rates for most of the targets (see Observation Description).										4	(COS.sp.100 5139)	(34) HD32778	COS/FUV, TIME-TAG, PSA	G130M 1291 A	BUFFER-TIME=46 5; FP-POS=3			565 Secs (565 Secs) [==>]	[1]	Comments: Note: ETC simulation (for G130M-1291, so as to include Ly-alpha) is for an "extreme" FUV spectrum, scaled to V=7.2 mag, and thus will over-predict count rates for most of the targets (see Observation Description).										5	(COS.sp.100 5139)	(34) HD32778	COS/FUV, TIME-TAG, PSA	G130M 1291 A	BUFFER-TIME=46 5; FP-POS=4			565 Secs (565 Secs) [==>]	[1]	Comments: Note: ETC simulation (for G130M-1291, so as to include Ly-alpha) is for an "extreme" FUV spectrum, scaled to V=7.2 mag, and thus will over-predict count rates for most of the targets (see Observation Description).									
	#	Label (ETC Run)	Target	Config,Mode,Aperture	Spectral Els.	Opt. Params.	Special Reqs.	Groups	Exp. Time (Total)/[Actual Dur.]	Orbit																																																																																																										
	1	(COS.ta.129 9645)	(34) HD32778	COS/NUV, ACQ/IMAGE, BOA	MIRRORB				45 Secs (45 Secs) [==>]	[1]																																																																																																										
	Comments: acquisition changed to MIRROR B (27 NOV 2018) to account for bluer color of target than expected for late-G spectral type; also compatible with the Galex NUV magnitude. ETC simulation done with Cas-Kur G2V model, V=+7.02.																																																																																																																			
	2	(COS.sp.100 5139)	(34) HD32778	COS/FUV, TIME-TAG, PSA	G130M 1222 A	BUFFER-TIME=46 5; FP-POS=3			565 Secs (565 Secs) [==>]	[1]																																																																																																										
	Comments: Note: ETC simulation (for G130M-1291, so as to include Ly-alpha) is for an "extreme" FUV spectrum, scaled to V=7.2 mag, and thus will over-predict count rates for most of the targets (see Observation Description).																																																																																																																			
3	(COS.sp.100 5139)	(34) HD32778	COS/FUV, TIME-TAG, PSA	G130M 1222 A	BUFFER-TIME=46 5; FP-POS=4			565 Secs (565 Secs) [==>]	[1]																																																																																																											
Comments: Note: ETC simulation (for G130M-1291, so as to include Ly-alpha) is for an "extreme" FUV spectrum, scaled to V=7.2 mag, and thus will over-predict count rates for most of the targets (see Observation Description).																																																																																																																				
4	(COS.sp.100 5139)	(34) HD32778	COS/FUV, TIME-TAG, PSA	G130M 1291 A	BUFFER-TIME=46 5; FP-POS=3			565 Secs (565 Secs) [==>]	[1]																																																																																																											
Comments: Note: ETC simulation (for G130M-1291, so as to include Ly-alpha) is for an "extreme" FUV spectrum, scaled to V=7.2 mag, and thus will over-predict count rates for most of the targets (see Observation Description).																																																																																																																				
5	(COS.sp.100 5139)	(34) HD32778	COS/FUV, TIME-TAG, PSA	G130M 1291 A	BUFFER-TIME=46 5; FP-POS=4			565 Secs (565 Secs) [==>]	[1]																																																																																																											
Comments: Note: ETC simulation (for G130M-1291, so as to include Ly-alpha) is for an "extreme" FUV spectrum, scaled to V=7.2 mag, and thus will over-predict count rates for most of the targets (see Observation Description).																																																																																																																				

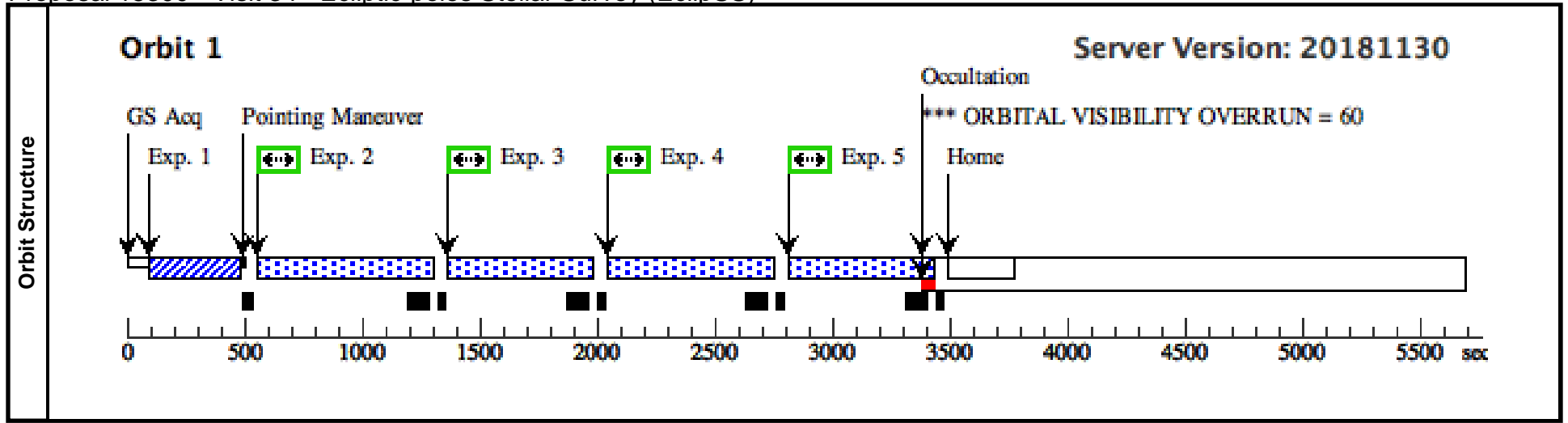

Proposal 15300 - Visit 35 - Ecliptic-poles Stellar Survey (EclipSS)

Thu Dec 13 22:02:08 GMT 2018

Visit	Proposal 15300, Visit 35, completed Diagnostic Status: Warning Scientific Instruments: COS/FUV, COS/NUV Special Requirements: (none)																																																																																																									
	(Visit 35) Warning (Form): For the best data quality, it is strongly recommended that the maximum number of allowed FP-POS positions is used when observing at a given COS CENWAVE setting. See full description for details. (Visit 35) Warning (Orbit Planner): ORBITAL VISIBILITY OVERRUN																																																																																																									
Diagnosics																																																																																																										
Fixed Targets	<table border="1"> <thead> <tr> <th>#</th> <th>Name</th> <th>Target Coordinates</th> <th>Targ. Coord. Corrections</th> <th>Fluxes</th> <th>Miscellaneous</th> </tr> </thead> <tbody> <tr> <td>(35)</td> <td>HD34297</td> <td>RA: 05 06 35.6907 (76.6487112d) Dec: -77 34 2.89 (-77.56747d) Equinox: J2000</td> <td>Proper Motion RA: 142.39 mas/yr Proper Motion Dec: -418.73 mas/yr Parallax: 0.02662" Epoch of Position: 2000 Radial Velocity: 0.0 km/sec</td> <td>V=7.31+/-0.1 sptyp= G8V; (B-V)= 0.66 mag; dist= 40 pc</td> <td>Reference Frame: ICRS</td> </tr> </tbody> </table>	#	Name	Target Coordinates	Targ. Coord. Corrections	Fluxes	Miscellaneous	(35)	HD34297	RA: 05 06 35.6907 (76.6487112d) Dec: -77 34 2.89 (-77.56747d) Equinox: J2000	Proper Motion RA: 142.39 mas/yr Proper Motion Dec: -418.73 mas/yr Parallax: 0.02662" Epoch of Position: 2000 Radial Velocity: 0.0 km/sec	V=7.31+/-0.1 sptyp= G8V; (B-V)= 0.66 mag; dist= 40 pc	Reference Frame: ICRS	Comments: Category=STAR Description=[G V-IV] Extended=NO																																																																																												
	#	Name	Target Coordinates	Targ. Coord. Corrections	Fluxes	Miscellaneous																																																																																																				
(35)	HD34297	RA: 05 06 35.6907 (76.6487112d) Dec: -77 34 2.89 (-77.56747d) Equinox: J2000	Proper Motion RA: 142.39 mas/yr Proper Motion Dec: -418.73 mas/yr Parallax: 0.02662" Epoch of Position: 2000 Radial Velocity: 0.0 km/sec	V=7.31+/-0.1 sptyp= G8V; (B-V)= 0.66 mag; dist= 40 pc	Reference Frame: ICRS																																																																																																					
Exposures	<table border="1"> <thead> <tr> <th>#</th> <th>Label (ETC Run)</th> <th>Target</th> <th>Config,Mode,Aperture</th> <th>Spectral Els.</th> <th>Opt. Params.</th> <th>Special Reqs.</th> <th>Groups</th> <th>Exp. Time (Total)/[Actual Dur.]</th> <th>Orbit</th> </tr> </thead> <tbody> <tr> <td>1</td> <td>(COS.ta.100 4302)</td> <td>(35) HD34297</td> <td>COS/NUV, ACQ/IMAGE, BOA</td> <td>MIRRORA</td> <td></td> <td></td> <td></td> <td>5 Secs (5 Secs) [==>]</td> <td>[1]</td> </tr> <tr> <td>2</td> <td>(COS.sp.100 5139)</td> <td>(35) HD34297</td> <td>COS/FUV, TIME-TAG, PSA</td> <td>G130M 1222 A</td> <td>BUFFER-TIME=51 7; FP-POS=3</td> <td></td> <td></td> <td>617 Secs (617 Secs) [==>]</td> <td>[1]</td> </tr> <tr> <td colspan="10"> Comments: Note: ETC simulation (for G130M-1291, so as to include Ly-alpha) is for an "extreme" FUV spectrum, scaled to V=7.2 mag, and thus will over-predict count rates for most of the targets (see Observation Description). </td> </tr> <tr> <td>3</td> <td>(COS.sp.100 5139)</td> <td>(35) HD34297</td> <td>COS/FUV, TIME-TAG, PSA</td> <td>G130M 1222 A</td> <td>BUFFER-TIME=51 7; FP-POS=4</td> <td></td> <td></td> <td>617 Secs (617 Secs) [==>]</td> <td>[1]</td> </tr> <tr> <td colspan="10"> Comments: Note: ETC simulation (for G130M-1291, so as to include Ly-alpha) is for an "extreme" FUV spectrum, scaled to V=7.2 mag, and thus will over-predict count rates for most of the targets (see Observation Description). </td> </tr> <tr> <td>4</td> <td>(COS.sp.100 5139)</td> <td>(35) HD34297</td> <td>COS/FUV, TIME-TAG, PSA</td> <td>G130M 1291 A</td> <td>BUFFER-TIME=51 7; FP-POS=3</td> <td></td> <td></td> <td>617 Secs (617 Secs) [==>]</td> <td>[1]</td> </tr> <tr> <td colspan="10"> Comments: Note: ETC simulation (for G130M-1291, so as to include Ly-alpha) is for an "extreme" FUV spectrum, scaled to V=7.2 mag, and thus will over-predict count rates for most of the targets (see Observation Description). </td> </tr> <tr> <td>5</td> <td>(COS.sp.100 5139)</td> <td>(35) HD34297</td> <td>COS/FUV, TIME-TAG, PSA</td> <td>G130M 1291 A</td> <td>BUFFER-TIME=51 7; FP-POS=4</td> <td></td> <td></td> <td>617 Secs (617 Secs) [==>]</td> <td>[1]</td> </tr> <tr> <td colspan="10"> Comments: Note: ETC simulation (for G130M-1291, so as to include Ly-alpha) is for an "extreme" FUV spectrum, scaled to V=7.2 mag, and thus will over-predict count rates for most of the targets (see Observation Description). </td> </tr> </tbody> </table>	#	Label (ETC Run)	Target	Config,Mode,Aperture	Spectral Els.	Opt. Params.	Special Reqs.	Groups	Exp. Time (Total)/[Actual Dur.]	Orbit	1	(COS.ta.100 4302)	(35) HD34297	COS/NUV, ACQ/IMAGE, BOA	MIRRORA				5 Secs (5 Secs) [==>]	[1]	2	(COS.sp.100 5139)	(35) HD34297	COS/FUV, TIME-TAG, PSA	G130M 1222 A	BUFFER-TIME=51 7; FP-POS=3			617 Secs (617 Secs) [==>]	[1]	Comments: Note: ETC simulation (for G130M-1291, so as to include Ly-alpha) is for an "extreme" FUV spectrum, scaled to V=7.2 mag, and thus will over-predict count rates for most of the targets (see Observation Description).										3	(COS.sp.100 5139)	(35) HD34297	COS/FUV, TIME-TAG, PSA	G130M 1222 A	BUFFER-TIME=51 7; FP-POS=4			617 Secs (617 Secs) [==>]	[1]	Comments: Note: ETC simulation (for G130M-1291, so as to include Ly-alpha) is for an "extreme" FUV spectrum, scaled to V=7.2 mag, and thus will over-predict count rates for most of the targets (see Observation Description).										4	(COS.sp.100 5139)	(35) HD34297	COS/FUV, TIME-TAG, PSA	G130M 1291 A	BUFFER-TIME=51 7; FP-POS=3			617 Secs (617 Secs) [==>]	[1]	Comments: Note: ETC simulation (for G130M-1291, so as to include Ly-alpha) is for an "extreme" FUV spectrum, scaled to V=7.2 mag, and thus will over-predict count rates for most of the targets (see Observation Description).										5	(COS.sp.100 5139)	(35) HD34297	COS/FUV, TIME-TAG, PSA	G130M 1291 A	BUFFER-TIME=51 7; FP-POS=4			617 Secs (617 Secs) [==>]	[1]	Comments: Note: ETC simulation (for G130M-1291, so as to include Ly-alpha) is for an "extreme" FUV spectrum, scaled to V=7.2 mag, and thus will over-predict count rates for most of the targets (see Observation Description).														
	#	Label (ETC Run)	Target	Config,Mode,Aperture	Spectral Els.	Opt. Params.	Special Reqs.	Groups	Exp. Time (Total)/[Actual Dur.]	Orbit																																																																																																
	1	(COS.ta.100 4302)	(35) HD34297	COS/NUV, ACQ/IMAGE, BOA	MIRRORA				5 Secs (5 Secs) [==>]	[1]																																																																																																
	2	(COS.sp.100 5139)	(35) HD34297	COS/FUV, TIME-TAG, PSA	G130M 1222 A	BUFFER-TIME=51 7; FP-POS=3			617 Secs (617 Secs) [==>]	[1]																																																																																																
	Comments: Note: ETC simulation (for G130M-1291, so as to include Ly-alpha) is for an "extreme" FUV spectrum, scaled to V=7.2 mag, and thus will over-predict count rates for most of the targets (see Observation Description).																																																																																																									
	3	(COS.sp.100 5139)	(35) HD34297	COS/FUV, TIME-TAG, PSA	G130M 1222 A	BUFFER-TIME=51 7; FP-POS=4			617 Secs (617 Secs) [==>]	[1]																																																																																																
Comments: Note: ETC simulation (for G130M-1291, so as to include Ly-alpha) is for an "extreme" FUV spectrum, scaled to V=7.2 mag, and thus will over-predict count rates for most of the targets (see Observation Description).																																																																																																										
4	(COS.sp.100 5139)	(35) HD34297	COS/FUV, TIME-TAG, PSA	G130M 1291 A	BUFFER-TIME=51 7; FP-POS=3			617 Secs (617 Secs) [==>]	[1]																																																																																																	
Comments: Note: ETC simulation (for G130M-1291, so as to include Ly-alpha) is for an "extreme" FUV spectrum, scaled to V=7.2 mag, and thus will over-predict count rates for most of the targets (see Observation Description).																																																																																																										
5	(COS.sp.100 5139)	(35) HD34297	COS/FUV, TIME-TAG, PSA	G130M 1291 A	BUFFER-TIME=51 7; FP-POS=4			617 Secs (617 Secs) [==>]	[1]																																																																																																	
Comments: Note: ETC simulation (for G130M-1291, so as to include Ly-alpha) is for an "extreme" FUV spectrum, scaled to V=7.2 mag, and thus will over-predict count rates for most of the targets (see Observation Description).																																																																																																										

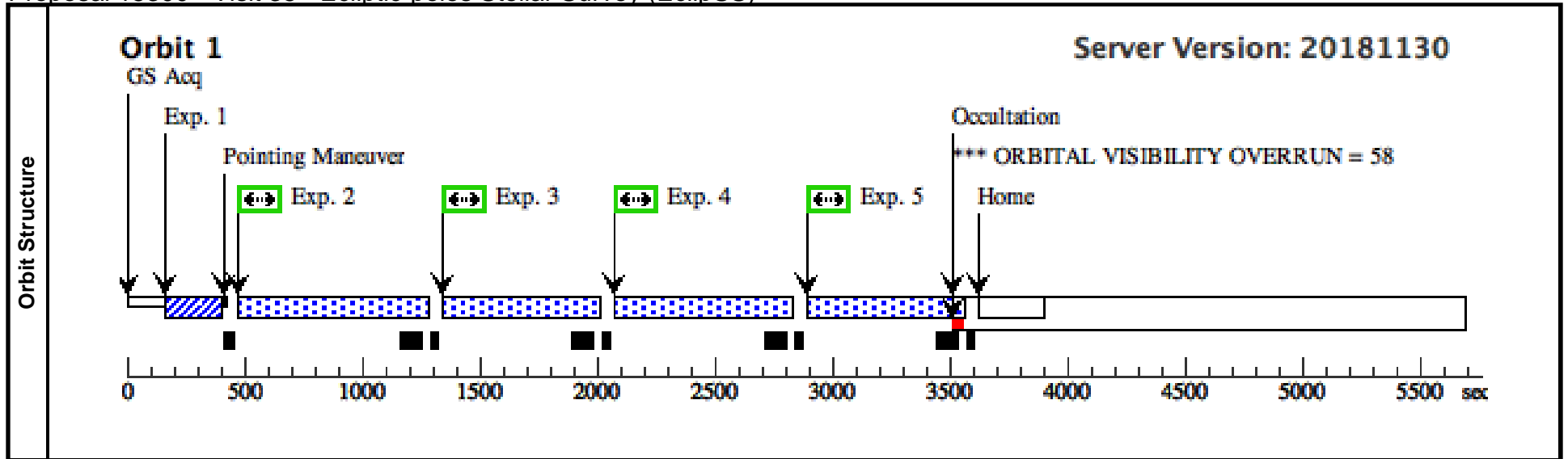

Proposal 15300 - Visit 36 - Ecliptic-poles Stellar Survey (EclipSS)

Thu Dec 13 22:02:08 GMT 2018

Visit	Proposal 15300, Visit 36, completed Diagnostic Status: Warning Scientific Instruments: COS/FUV, COS/NUV Special Requirements: (none)																																																																																																									
	(Visit 36) Warning (Form): For the best data quality, it is strongly recommended that the maximum number of allowed FP-POS positions is used when observing at a given COS CENWAVE setting. See full description for details. (Visit 36) Warning (Orbit Planner): ORBITAL VISIBILITY OVERRUN																																																																																																									
Diagnosics																																																																																																										
Fixed Targets	<table border="1"> <thead> <tr> <th>#</th> <th>Name</th> <th>Target Coordinates</th> <th>Targ. Coord. Corrections</th> <th>Fluxes</th> <th>Miscellaneous</th> </tr> </thead> <tbody> <tr> <td>(36)</td> <td>HD199476</td> <td>RA: 20 51 44.9454 (312.9372725d) Dec: +74 46 49.18 (74.78033d) Equinox: J2000</td> <td>Proper Motion RA: 402.89 mas/yr Proper Motion Dec: 575.32 mas/yr Parallax: 0.03297" Epoch of Position: 2000 Radial Velocity: 0.0 km/sec</td> <td>V=7.81+/-0.1 sptyp= G8V; (B-V)= 0.70 mag; dist= 30 pc</td> <td>Reference Frame: ICRS</td> </tr> </tbody> </table>	#	Name	Target Coordinates	Targ. Coord. Corrections	Fluxes	Miscellaneous	(36)	HD199476	RA: 20 51 44.9454 (312.9372725d) Dec: +74 46 49.18 (74.78033d) Equinox: J2000	Proper Motion RA: 402.89 mas/yr Proper Motion Dec: 575.32 mas/yr Parallax: 0.03297" Epoch of Position: 2000 Radial Velocity: 0.0 km/sec	V=7.81+/-0.1 sptyp= G8V; (B-V)= 0.70 mag; dist= 30 pc	Reference Frame: ICRS	Comments: Category=STAR Description=[G V-IV] Extended=NO																																																																																												
	#	Name	Target Coordinates	Targ. Coord. Corrections	Fluxes	Miscellaneous																																																																																																				
(36)	HD199476	RA: 20 51 44.9454 (312.9372725d) Dec: +74 46 49.18 (74.78033d) Equinox: J2000	Proper Motion RA: 402.89 mas/yr Proper Motion Dec: 575.32 mas/yr Parallax: 0.03297" Epoch of Position: 2000 Radial Velocity: 0.0 km/sec	V=7.81+/-0.1 sptyp= G8V; (B-V)= 0.70 mag; dist= 30 pc	Reference Frame: ICRS																																																																																																					
Exposures	<table border="1"> <thead> <tr> <th>#</th> <th>Label (ETC Run)</th> <th>Target</th> <th>Config,Mode,Aperture</th> <th>Spectral Els.</th> <th>Opt. Params.</th> <th>Special Reqs.</th> <th>Groups</th> <th>Exp. Time (Total)/[Actual Dur.]</th> <th>Orbit</th> </tr> </thead> <tbody> <tr> <td>1</td> <td>(COS.ta.100 4320)</td> <td>(36) HD199476</td> <td>COS/NUV, ACQ/IMAGE, BOA</td> <td>MIRRORA</td> <td></td> <td></td> <td></td> <td>6 Secs (6 Secs) [==>]</td> <td>[1]</td> </tr> <tr> <td>2</td> <td>(COS.sp.100 5139)</td> <td>(36) HD199476</td> <td>COS/FUV, TIME-TAG, PSA</td> <td>G130M 1222 A</td> <td>BUFFER-TIME=51 8; FP-POS=3</td> <td></td> <td></td> <td>618 Secs (618 Secs) [==>]</td> <td>[1]</td> </tr> <tr> <td colspan="10"> Comments: Note: ETC simulation (for G130M-1291, so as to include Ly-alpha) is for an "extreme" FUV spectrum, scaled to V=7.2 mag, and thus will over-predict count rates for most of the targets (see Observation Description). </td> </tr> <tr> <td>3</td> <td>(COS.sp.100 5139)</td> <td>(36) HD199476</td> <td>COS/FUV, TIME-TAG, PSA</td> <td>G130M 1222 A</td> <td>BUFFER-TIME=51 8; FP-POS=4</td> <td></td> <td></td> <td>618 Secs (618 Secs) [==>]</td> <td>[1]</td> </tr> <tr> <td colspan="10"> Comments: Note: ETC simulation (for G130M-1291, so as to include Ly-alpha) is for an "extreme" FUV spectrum, scaled to V=7.2 mag, and thus will over-predict count rates for most of the targets (see Observation Description). </td> </tr> <tr> <td>4</td> <td>(COS.sp.100 5139)</td> <td>(36) HD199476</td> <td>COS/FUV, TIME-TAG, PSA</td> <td>G130M 1291 A</td> <td>BUFFER-TIME=51 8; FP-POS=3</td> <td></td> <td></td> <td>618 Secs (618 Secs) [==>]</td> <td>[1]</td> </tr> <tr> <td colspan="10"> Comments: Note: ETC simulation (for G130M-1291, so as to include Ly-alpha) is for an "extreme" FUV spectrum, scaled to V=7.2 mag, and thus will over-predict count rates for most of the targets (see Observation Description). </td> </tr> <tr> <td>5</td> <td>(COS.sp.100 5139)</td> <td>(36) HD199476</td> <td>COS/FUV, TIME-TAG, PSA</td> <td>G130M 1291 A</td> <td>BUFFER-TIME=51 8; FP-POS=4</td> <td></td> <td></td> <td>618 Secs (618 Secs) [==>]</td> <td>[1]</td> </tr> <tr> <td colspan="10"> Comments: Note: ETC simulation (for G130M-1291, so as to include Ly-alpha) is for an "extreme" FUV spectrum, scaled to V=7.2 mag, and thus will over-predict count rates for most of the targets (see Observation Description). </td> </tr> </tbody> </table>	#	Label (ETC Run)	Target	Config,Mode,Aperture	Spectral Els.	Opt. Params.	Special Reqs.	Groups	Exp. Time (Total)/[Actual Dur.]	Orbit	1	(COS.ta.100 4320)	(36) HD199476	COS/NUV, ACQ/IMAGE, BOA	MIRRORA				6 Secs (6 Secs) [==>]	[1]	2	(COS.sp.100 5139)	(36) HD199476	COS/FUV, TIME-TAG, PSA	G130M 1222 A	BUFFER-TIME=51 8; FP-POS=3			618 Secs (618 Secs) [==>]	[1]	Comments: Note: ETC simulation (for G130M-1291, so as to include Ly-alpha) is for an "extreme" FUV spectrum, scaled to V=7.2 mag, and thus will over-predict count rates for most of the targets (see Observation Description).										3	(COS.sp.100 5139)	(36) HD199476	COS/FUV, TIME-TAG, PSA	G130M 1222 A	BUFFER-TIME=51 8; FP-POS=4			618 Secs (618 Secs) [==>]	[1]	Comments: Note: ETC simulation (for G130M-1291, so as to include Ly-alpha) is for an "extreme" FUV spectrum, scaled to V=7.2 mag, and thus will over-predict count rates for most of the targets (see Observation Description).										4	(COS.sp.100 5139)	(36) HD199476	COS/FUV, TIME-TAG, PSA	G130M 1291 A	BUFFER-TIME=51 8; FP-POS=3			618 Secs (618 Secs) [==>]	[1]	Comments: Note: ETC simulation (for G130M-1291, so as to include Ly-alpha) is for an "extreme" FUV spectrum, scaled to V=7.2 mag, and thus will over-predict count rates for most of the targets (see Observation Description).										5	(COS.sp.100 5139)	(36) HD199476	COS/FUV, TIME-TAG, PSA	G130M 1291 A	BUFFER-TIME=51 8; FP-POS=4			618 Secs (618 Secs) [==>]	[1]	Comments: Note: ETC simulation (for G130M-1291, so as to include Ly-alpha) is for an "extreme" FUV spectrum, scaled to V=7.2 mag, and thus will over-predict count rates for most of the targets (see Observation Description).														
	#	Label (ETC Run)	Target	Config,Mode,Aperture	Spectral Els.	Opt. Params.	Special Reqs.	Groups	Exp. Time (Total)/[Actual Dur.]	Orbit																																																																																																
	1	(COS.ta.100 4320)	(36) HD199476	COS/NUV, ACQ/IMAGE, BOA	MIRRORA				6 Secs (6 Secs) [==>]	[1]																																																																																																
	2	(COS.sp.100 5139)	(36) HD199476	COS/FUV, TIME-TAG, PSA	G130M 1222 A	BUFFER-TIME=51 8; FP-POS=3			618 Secs (618 Secs) [==>]	[1]																																																																																																
	Comments: Note: ETC simulation (for G130M-1291, so as to include Ly-alpha) is for an "extreme" FUV spectrum, scaled to V=7.2 mag, and thus will over-predict count rates for most of the targets (see Observation Description).																																																																																																									
	3	(COS.sp.100 5139)	(36) HD199476	COS/FUV, TIME-TAG, PSA	G130M 1222 A	BUFFER-TIME=51 8; FP-POS=4			618 Secs (618 Secs) [==>]	[1]																																																																																																
Comments: Note: ETC simulation (for G130M-1291, so as to include Ly-alpha) is for an "extreme" FUV spectrum, scaled to V=7.2 mag, and thus will over-predict count rates for most of the targets (see Observation Description).																																																																																																										
4	(COS.sp.100 5139)	(36) HD199476	COS/FUV, TIME-TAG, PSA	G130M 1291 A	BUFFER-TIME=51 8; FP-POS=3			618 Secs (618 Secs) [==>]	[1]																																																																																																	
Comments: Note: ETC simulation (for G130M-1291, so as to include Ly-alpha) is for an "extreme" FUV spectrum, scaled to V=7.2 mag, and thus will over-predict count rates for most of the targets (see Observation Description).																																																																																																										
5	(COS.sp.100 5139)	(36) HD199476	COS/FUV, TIME-TAG, PSA	G130M 1291 A	BUFFER-TIME=51 8; FP-POS=4			618 Secs (618 Secs) [==>]	[1]																																																																																																	
Comments: Note: ETC simulation (for G130M-1291, so as to include Ly-alpha) is for an "extreme" FUV spectrum, scaled to V=7.2 mag, and thus will over-predict count rates for most of the targets (see Observation Description).																																																																																																										

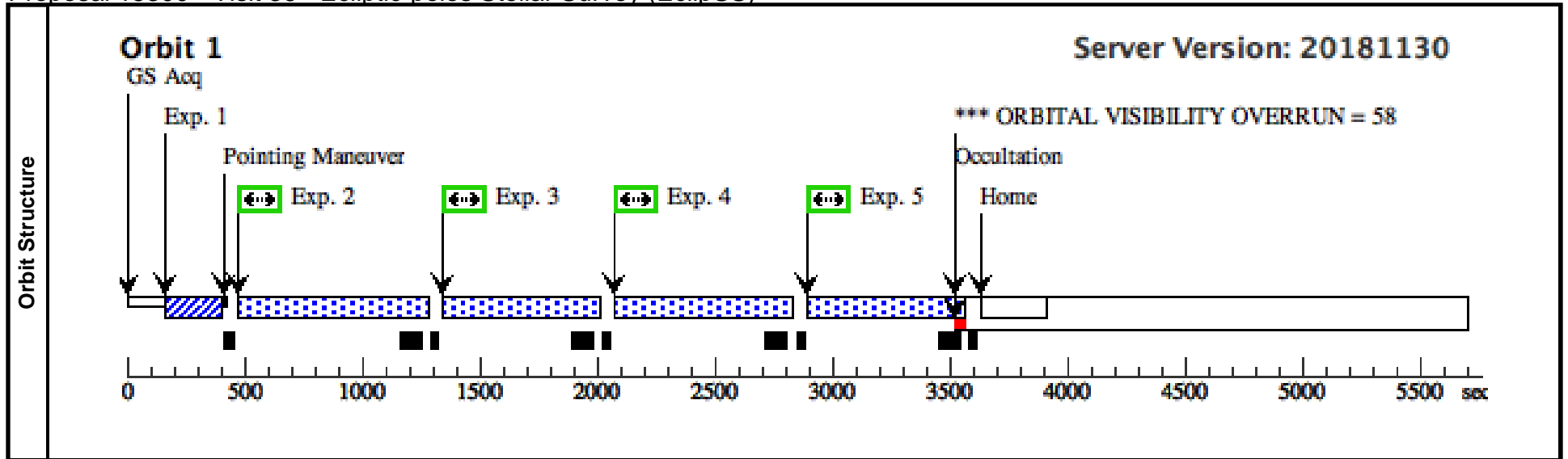

Proposal 15300 - Visit 37 - Ecliptic-poles Stellar Survey (EclipSS)

Thu Dec 13 22:02:08 GMT 2018

Visit	Proposal 15300, Visit 37, completed Diagnostic Status: Warning Scientific Instruments: COS/FUV, COS/NUV Special Requirements: (none)																																																																																																								
	(Visit 37) Warning (Form): For the best data quality, it is strongly recommended that the maximum number of allowed FP-POS positions is used when observing at a given COS CENWAVE setting. See full description for details. (Visit 37) Warning (Orbit Planner): ORBITAL VISIBILITY OVERRUN																																																																																																								
Diagnosics																																																																																																									
Fixed Targets	<table border="1"> <thead> <tr> <th>#</th> <th>Name</th> <th>Target Coordinates</th> <th>Targ. Coord. Corrections</th> <th>Fluxes</th> <th>Miscellaneous</th> </tr> </thead> <tbody> <tr> <td>(37)</td> <td>HD55720</td> <td>RA: 07 11 31.6681 (107.8819504d) Dec: -49 25 27.14 (-49.42421d) Equinox: J2000</td> <td>Proper Motion RA: -6.27 mas/yr Proper Motion Dec: 817.79 mas/yr Parallax: 0.03616" Epoch of Position: 2000 Radial Velocity: 0.0 km/sec</td> <td>V=7.47+/-0.1 sptyp= G8V; (B-V)= 0.77 mag; dist= 28 pc</td> <td>Reference Frame: ICRS</td> </tr> </tbody> </table>	#	Name	Target Coordinates	Targ. Coord. Corrections	Fluxes	Miscellaneous	(37)	HD55720	RA: 07 11 31.6681 (107.8819504d) Dec: -49 25 27.14 (-49.42421d) Equinox: J2000	Proper Motion RA: -6.27 mas/yr Proper Motion Dec: 817.79 mas/yr Parallax: 0.03616" Epoch of Position: 2000 Radial Velocity: 0.0 km/sec	V=7.47+/-0.1 sptyp= G8V; (B-V)= 0.77 mag; dist= 28 pc	Reference Frame: ICRS	Comments: Category=STAR Description=[G V-IV] Extended=NO																																																																																											
	#	Name	Target Coordinates	Targ. Coord. Corrections	Fluxes	Miscellaneous																																																																																																			
(37)	HD55720	RA: 07 11 31.6681 (107.8819504d) Dec: -49 25 27.14 (-49.42421d) Equinox: J2000	Proper Motion RA: -6.27 mas/yr Proper Motion Dec: 817.79 mas/yr Parallax: 0.03616" Epoch of Position: 2000 Radial Velocity: 0.0 km/sec	V=7.47+/-0.1 sptyp= G8V; (B-V)= 0.77 mag; dist= 28 pc	Reference Frame: ICRS																																																																																																				
<table border="1"> <thead> <tr> <th>#</th> <th>Label (ETC Run)</th> <th>Target</th> <th>Config,Mode,Aperture</th> <th>Spectral Els.</th> <th>Opt. Params.</th> <th>Special Reqs.</th> <th>Groups</th> <th>Exp. Time (Total)/[Actual Dur.]</th> <th>Orbit</th> </tr> </thead> <tbody> <tr> <td>1</td> <td>(COS.ta.100 4321)</td> <td>(37) HD55720</td> <td>COS/NUV, ACQ/IMAGE, BOA</td> <td>MIRRORA</td> <td></td> <td></td> <td></td> <td>6 Secs (6 Secs) [==>]</td> <td>[1]</td> </tr> <tr> <td>2</td> <td>(COS.sp.100 5139)</td> <td>(37) HD55720</td> <td>COS/FUV, TIME-TAG, PSA</td> <td>G130M 1222 A</td> <td>BUFFER-TIME=45 8; FP-POS=3</td> <td></td> <td></td> <td>558 Secs (558 Secs) [==>]</td> <td>[1]</td> </tr> <tr> <td colspan="10"> Comments: Note: ETC simulation (for G130M-1291, so as to include Ly-alpha) is for an "extreme" FUV spectrum, scaled to V=7.2 mag, and thus will over-predict count rates for most of the targets (see Observation Description). </td> </tr> <tr> <td>3</td> <td>(COS.sp.100 5139)</td> <td>(37) HD55720</td> <td>COS/FUV, TIME-TAG, PSA</td> <td>G130M 1222 A</td> <td>BUFFER-TIME=45 8; FP-POS=4</td> <td></td> <td></td> <td>558 Secs (558 Secs) [==>]</td> <td>[1]</td> </tr> <tr> <td colspan="10"> Comments: Note: ETC simulation (for G130M-1291, so as to include Ly-alpha) is for an "extreme" FUV spectrum, scaled to V=7.2 mag, and thus will over-predict count rates for most of the targets (see Observation Description). </td> </tr> <tr> <td>4</td> <td>(COS.sp.100 5139)</td> <td>(37) HD55720</td> <td>COS/FUV, TIME-TAG, PSA</td> <td>G130M 1291 A</td> <td>BUFFER-TIME=45 8; FP-POS=3</td> <td></td> <td></td> <td>558 Secs (558 Secs) [==>]</td> <td>[1]</td> </tr> <tr> <td colspan="10"> Comments: Note: ETC simulation (for G130M-1291, so as to include Ly-alpha) is for an "extreme" FUV spectrum, scaled to V=7.2 mag, and thus will over-predict count rates for most of the targets (see Observation Description). </td> </tr> <tr> <td>5</td> <td>(COS.sp.100 5139)</td> <td>(37) HD55720</td> <td>COS/FUV, TIME-TAG, PSA</td> <td>G130M 1291 A</td> <td>BUFFER-TIME=45 8; FP-POS=4</td> <td></td> <td></td> <td>558 Secs (558 Secs) [==>]</td> <td>[1]</td> </tr> <tr> <td colspan="10"> Comments: Note: ETC simulation (for G130M-1291, so as to include Ly-alpha) is for an "extreme" FUV spectrum, scaled to V=7.2 mag, and thus will over-predict count rates for most of the targets (see Observation Description). </td> </tr> </tbody> </table>						#	Label (ETC Run)	Target	Config,Mode,Aperture	Spectral Els.	Opt. Params.	Special Reqs.	Groups	Exp. Time (Total)/[Actual Dur.]	Orbit	1	(COS.ta.100 4321)	(37) HD55720	COS/NUV, ACQ/IMAGE, BOA	MIRRORA				6 Secs (6 Secs) [==>]	[1]	2	(COS.sp.100 5139)	(37) HD55720	COS/FUV, TIME-TAG, PSA	G130M 1222 A	BUFFER-TIME=45 8; FP-POS=3			558 Secs (558 Secs) [==>]	[1]	Comments: Note: ETC simulation (for G130M-1291, so as to include Ly-alpha) is for an "extreme" FUV spectrum, scaled to V=7.2 mag, and thus will over-predict count rates for most of the targets (see Observation Description).										3	(COS.sp.100 5139)	(37) HD55720	COS/FUV, TIME-TAG, PSA	G130M 1222 A	BUFFER-TIME=45 8; FP-POS=4			558 Secs (558 Secs) [==>]	[1]	Comments: Note: ETC simulation (for G130M-1291, so as to include Ly-alpha) is for an "extreme" FUV spectrum, scaled to V=7.2 mag, and thus will over-predict count rates for most of the targets (see Observation Description).										4	(COS.sp.100 5139)	(37) HD55720	COS/FUV, TIME-TAG, PSA	G130M 1291 A	BUFFER-TIME=45 8; FP-POS=3			558 Secs (558 Secs) [==>]	[1]	Comments: Note: ETC simulation (for G130M-1291, so as to include Ly-alpha) is for an "extreme" FUV spectrum, scaled to V=7.2 mag, and thus will over-predict count rates for most of the targets (see Observation Description).										5	(COS.sp.100 5139)	(37) HD55720	COS/FUV, TIME-TAG, PSA	G130M 1291 A	BUFFER-TIME=45 8; FP-POS=4			558 Secs (558 Secs) [==>]	[1]	Comments: Note: ETC simulation (for G130M-1291, so as to include Ly-alpha) is for an "extreme" FUV spectrum, scaled to V=7.2 mag, and thus will over-predict count rates for most of the targets (see Observation Description).									
#	Label (ETC Run)	Target	Config,Mode,Aperture	Spectral Els.	Opt. Params.	Special Reqs.	Groups	Exp. Time (Total)/[Actual Dur.]	Orbit																																																																																																
1	(COS.ta.100 4321)	(37) HD55720	COS/NUV, ACQ/IMAGE, BOA	MIRRORA				6 Secs (6 Secs) [==>]	[1]																																																																																																
2	(COS.sp.100 5139)	(37) HD55720	COS/FUV, TIME-TAG, PSA	G130M 1222 A	BUFFER-TIME=45 8; FP-POS=3			558 Secs (558 Secs) [==>]	[1]																																																																																																
Comments: Note: ETC simulation (for G130M-1291, so as to include Ly-alpha) is for an "extreme" FUV spectrum, scaled to V=7.2 mag, and thus will over-predict count rates for most of the targets (see Observation Description).																																																																																																									
3	(COS.sp.100 5139)	(37) HD55720	COS/FUV, TIME-TAG, PSA	G130M 1222 A	BUFFER-TIME=45 8; FP-POS=4			558 Secs (558 Secs) [==>]	[1]																																																																																																
Comments: Note: ETC simulation (for G130M-1291, so as to include Ly-alpha) is for an "extreme" FUV spectrum, scaled to V=7.2 mag, and thus will over-predict count rates for most of the targets (see Observation Description).																																																																																																									
4	(COS.sp.100 5139)	(37) HD55720	COS/FUV, TIME-TAG, PSA	G130M 1291 A	BUFFER-TIME=45 8; FP-POS=3			558 Secs (558 Secs) [==>]	[1]																																																																																																
Comments: Note: ETC simulation (for G130M-1291, so as to include Ly-alpha) is for an "extreme" FUV spectrum, scaled to V=7.2 mag, and thus will over-predict count rates for most of the targets (see Observation Description).																																																																																																									
5	(COS.sp.100 5139)	(37) HD55720	COS/FUV, TIME-TAG, PSA	G130M 1291 A	BUFFER-TIME=45 8; FP-POS=4			558 Secs (558 Secs) [==>]	[1]																																																																																																
Comments: Note: ETC simulation (for G130M-1291, so as to include Ly-alpha) is for an "extreme" FUV spectrum, scaled to V=7.2 mag, and thus will over-predict count rates for most of the targets (see Observation Description).																																																																																																									
Exposures																																																																																																									

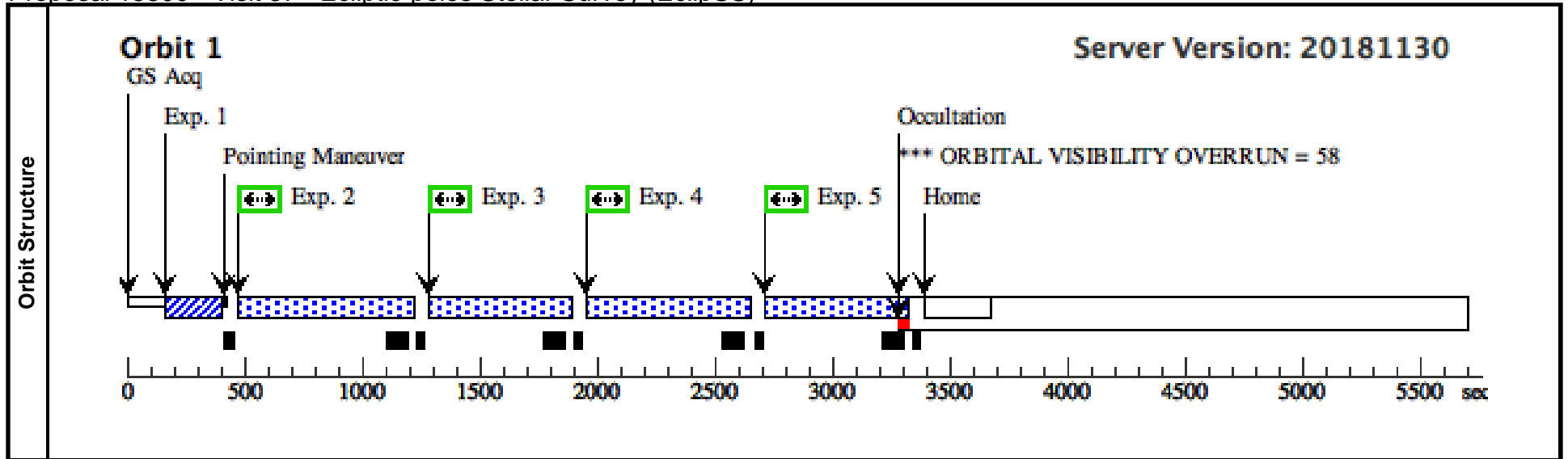

Proposal 15300 - Visit 38 - Ecliptic-poles Stellar Survey (EclipSS)

Thu Dec 13 22:02:08 GMT 2018

Visit	Proposal 15300, Visit 38, completed Diagnostic Status: Warning Scientific Instruments: COS/FUV, COS/NUV Special Requirements: (none)										
	(Visit 38) Warning (Form): For the best data quality, it is strongly recommended that the maximum number of allowed FP-POS positions is used when observing at a given COS CENWAVE setting. See full description for details. (Visit 38) Warning (Orbit Planner): ORBITAL VISIBILITY OVERRUN										
Fixed Targets	#	Name	Target Coordinates	Targ. Coord. Corrections	Fluxes	Miscellaneous					
	(38)	HD63765	RA: 07 47 49.7189 (116.9571621d) Dec: -54 15 50.93 (-54.26415d) Equinox: J2000	Proper Motion RA: 147.67 mas/yr Proper Motion Dec: -279.19 mas/yr Parallax: 0.03007" Epoch of Position: 2000 Radial Velocity: 0.0 km/sec	V=8.10+/-0.1 sptyp= G9V; (B-V)= 0.75 mag; dist= 32 pc	Reference Frame: ICRS					
Comments: Category=STAR Description=[G V-IV] Extended=NO											
Exposures	#	Label (ETC Run)	Target	Config,Mode,Aperture	Spectral Els.	Opt. Params.	Special Reqs.	Groups	Exp. Time (Total)/[Actual Dur.]	Orbit	
	1	(COS.ta.100 4323)	(38) HD63765	COS/NUV, ACQ/IMAGE, BOA	MIRRORA				8 Secs (8 Secs) [==>]	[1]	
	2	(COS.sp.100 5139)	(38) HD63765	COS/FUV, TIME-TAG, PSA	G130M 1222 A	BUFFER-TIME=46 9; FP-POS=3			569 Secs (569 Secs) [==>]	[1]	
	Comments: Note: ETC simulation (for G130M-1291, so as to include Ly-alpha) is for an "extreme" FUV spectrum, scaled to V=7.2 mag, and thus will over-predict count rates for most of the targets (see Observation Description).										
	3	(COS.sp.100 5139)	(38) HD63765	COS/FUV, TIME-TAG, PSA	G130M 1222 A	BUFFER-TIME=46 9; FP-POS=4			569 Secs (569 Secs) [==>]	[1]	
	Comments: Note: ETC simulation (for G130M-1291, so as to include Ly-alpha) is for an "extreme" FUV spectrum, scaled to V=7.2 mag, and thus will over-predict count rates for most of the targets (see Observation Description).										
4	(COS.sp.100 5139)	(38) HD63765	COS/FUV, TIME-TAG, PSA	G130M 1291 A	BUFFER-TIME=46 9; FP-POS=3			569 Secs (569 Secs) [==>]	[1]		
Comments: Note: ETC simulation (for G130M-1291, so as to include Ly-alpha) is for an "extreme" FUV spectrum, scaled to V=7.2 mag, and thus will over-predict count rates for most of the targets (see Observation Description).											
5	(COS.sp.100 5139)	(38) HD63765	COS/FUV, TIME-TAG, PSA	G130M 1291 A	BUFFER-TIME=46 9; FP-POS=4			569 Secs (569 Secs) [==>]	[1]		
Comments: Note: ETC simulation (for G130M-1291, so as to include Ly-alpha) is for an "extreme" FUV spectrum, scaled to V=7.2 mag, and thus will over-predict count rates for most of the targets (see Observation Description).											

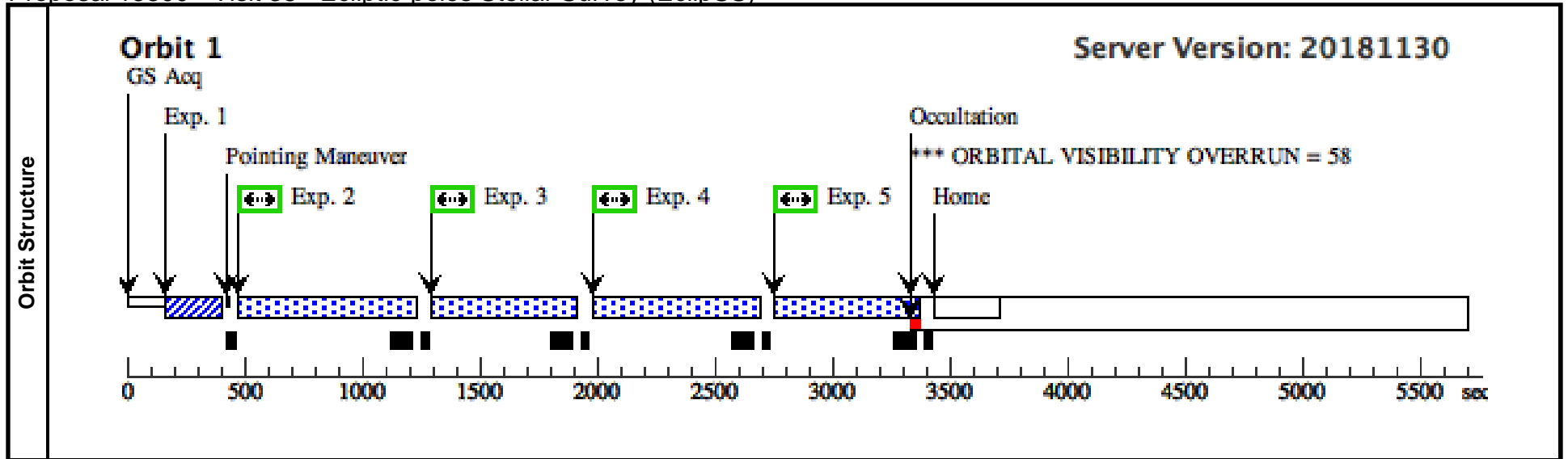

Proposal 15300 - Visit 39 - Ecliptic-poles Stellar Survey (EclipSS)

Thu Dec 13 22:02:08 GMT 2018

Visit	Proposal 15300, Visit 39, completed Diagnostic Status: Warning Scientific Instruments: COS/FUV, COS/NUV Special Requirements: (none)																																																																																																									
	(Visit 39) Warning (Form): For the best data quality, it is strongly recommended that the maximum number of allowed FP-POS positions is used when observing at a given COS CENWAVE setting. See full description for details. (Visit 39) Warning (Orbit Planner): ORBITAL VISIBILITY OVERRUN																																																																																																									
Diagnosics																																																																																																										
Fixed Targets	<table border="1"> <thead> <tr> <th>#</th> <th>Name</th> <th>Target Coordinates</th> <th>Targ. Coord. Corrections</th> <th>Fluxes</th> <th>Miscellaneous</th> </tr> </thead> <tbody> <tr> <td>(39)</td> <td>HD161897</td> <td>RA: 17 41 6.6994 (265.2779142d) Dec: +72 25 13.24 (72.42034d) Equinox: J2000</td> <td>Proper Motion RA: -121.99 mas/yr Proper Motion Dec: 297.94 mas/yr Parallax: 0.03330" Epoch of Position: 2000 Radial Velocity: 0.0 km/sec</td> <td>V=7.61+/-0.1 sptyp= K0V; (B-V)= 0.72 mag; dist= 30 pc</td> <td>Reference Frame: ICRS</td> </tr> </tbody> </table>	#	Name	Target Coordinates	Targ. Coord. Corrections	Fluxes	Miscellaneous	(39)	HD161897	RA: 17 41 6.6994 (265.2779142d) Dec: +72 25 13.24 (72.42034d) Equinox: J2000	Proper Motion RA: -121.99 mas/yr Proper Motion Dec: 297.94 mas/yr Parallax: 0.03330" Epoch of Position: 2000 Radial Velocity: 0.0 km/sec	V=7.61+/-0.1 sptyp= K0V; (B-V)= 0.72 mag; dist= 30 pc	Reference Frame: ICRS	Comments: Category=STAR Description=[K V-IV] Extended=NO																																																																																												
	#	Name	Target Coordinates	Targ. Coord. Corrections	Fluxes	Miscellaneous																																																																																																				
(39)	HD161897	RA: 17 41 6.6994 (265.2779142d) Dec: +72 25 13.24 (72.42034d) Equinox: J2000	Proper Motion RA: -121.99 mas/yr Proper Motion Dec: 297.94 mas/yr Parallax: 0.03330" Epoch of Position: 2000 Radial Velocity: 0.0 km/sec	V=7.61+/-0.1 sptyp= K0V; (B-V)= 0.72 mag; dist= 30 pc	Reference Frame: ICRS																																																																																																					
Exposures	<table border="1"> <thead> <tr> <th>#</th> <th>Label (ETC Run)</th> <th>Target</th> <th>Config,Mode,Aperture</th> <th>Spectral Els.</th> <th>Opt. Params.</th> <th>Special Reqs.</th> <th>Groups</th> <th>Exp. Time (Total)/[Actual Dur.]</th> <th>Orbit</th> </tr> </thead> <tbody> <tr> <td>1</td> <td>(COS.ta.100 4326)</td> <td>(39) HD161897</td> <td>COS/NUV, ACQ/IMAGE, BOA</td> <td>MIRRORA</td> <td></td> <td></td> <td></td> <td>8 Secs (8 Secs) [==>]</td> <td>[1]</td> </tr> <tr> <td>2</td> <td>(COS.sp.100 5139)</td> <td>(39) HD161897</td> <td>COS/FUV, TIME-TAG, PSA</td> <td>G130M 1222 A</td> <td>BUFFER-TIME=51 7; FP-POS=3</td> <td></td> <td></td> <td>617 Secs (617 Secs) [==>]</td> <td>[1]</td> </tr> <tr> <td colspan="10"> Comments: Note: ETC simulation (for G130M-1291, so as to include Ly-alpha) is for an "extreme" FUV spectrum, scaled to V=7.2 mag, and thus will over-predict count rates for most of the targets (see Observation Description). </td> </tr> <tr> <td>3</td> <td>(COS.sp.100 5139)</td> <td>(39) HD161897</td> <td>COS/FUV, TIME-TAG, PSA</td> <td>G130M 1222 A</td> <td>BUFFER-TIME=51 7; FP-POS=4</td> <td></td> <td></td> <td>617 Secs (617 Secs) [==>]</td> <td>[1]</td> </tr> <tr> <td colspan="10"> Comments: Note: ETC simulation (for G130M-1291, so as to include Ly-alpha) is for an "extreme" FUV spectrum, scaled to V=7.2 mag, and thus will over-predict count rates for most of the targets (see Observation Description). </td> </tr> <tr> <td>4</td> <td>(COS.sp.100 5139)</td> <td>(39) HD161897</td> <td>COS/FUV, TIME-TAG, PSA</td> <td>G130M 1291 A</td> <td>BUFFER-TIME=51 7; FP-POS=3</td> <td></td> <td></td> <td>617 Secs (617 Secs) [==>]</td> <td>[1]</td> </tr> <tr> <td colspan="10"> Comments: Note: ETC simulation (for G130M-1291, so as to include Ly-alpha) is for an "extreme" FUV spectrum, scaled to V=7.2 mag, and thus will over-predict count rates for most of the targets (see Observation Description). </td> </tr> <tr> <td>5</td> <td>(COS.sp.100 5139)</td> <td>(39) HD161897</td> <td>COS/FUV, TIME-TAG, PSA</td> <td>G130M 1291 A</td> <td>BUFFER-TIME=51 7; FP-POS=4</td> <td></td> <td></td> <td>617 Secs (617 Secs) [==>]</td> <td>[1]</td> </tr> <tr> <td colspan="10"> Comments: Note: ETC simulation (for G130M-1291, so as to include Ly-alpha) is for an "extreme" FUV spectrum, scaled to V=7.2 mag, and thus will over-predict count rates for most of the targets (see Observation Description). </td> </tr> </tbody> </table>	#	Label (ETC Run)	Target	Config,Mode,Aperture	Spectral Els.	Opt. Params.	Special Reqs.	Groups	Exp. Time (Total)/[Actual Dur.]	Orbit	1	(COS.ta.100 4326)	(39) HD161897	COS/NUV, ACQ/IMAGE, BOA	MIRRORA				8 Secs (8 Secs) [==>]	[1]	2	(COS.sp.100 5139)	(39) HD161897	COS/FUV, TIME-TAG, PSA	G130M 1222 A	BUFFER-TIME=51 7; FP-POS=3			617 Secs (617 Secs) [==>]	[1]	Comments: Note: ETC simulation (for G130M-1291, so as to include Ly-alpha) is for an "extreme" FUV spectrum, scaled to V=7.2 mag, and thus will over-predict count rates for most of the targets (see Observation Description).										3	(COS.sp.100 5139)	(39) HD161897	COS/FUV, TIME-TAG, PSA	G130M 1222 A	BUFFER-TIME=51 7; FP-POS=4			617 Secs (617 Secs) [==>]	[1]	Comments: Note: ETC simulation (for G130M-1291, so as to include Ly-alpha) is for an "extreme" FUV spectrum, scaled to V=7.2 mag, and thus will over-predict count rates for most of the targets (see Observation Description).										4	(COS.sp.100 5139)	(39) HD161897	COS/FUV, TIME-TAG, PSA	G130M 1291 A	BUFFER-TIME=51 7; FP-POS=3			617 Secs (617 Secs) [==>]	[1]	Comments: Note: ETC simulation (for G130M-1291, so as to include Ly-alpha) is for an "extreme" FUV spectrum, scaled to V=7.2 mag, and thus will over-predict count rates for most of the targets (see Observation Description).										5	(COS.sp.100 5139)	(39) HD161897	COS/FUV, TIME-TAG, PSA	G130M 1291 A	BUFFER-TIME=51 7; FP-POS=4			617 Secs (617 Secs) [==>]	[1]	Comments: Note: ETC simulation (for G130M-1291, so as to include Ly-alpha) is for an "extreme" FUV spectrum, scaled to V=7.2 mag, and thus will over-predict count rates for most of the targets (see Observation Description).														
	#	Label (ETC Run)	Target	Config,Mode,Aperture	Spectral Els.	Opt. Params.	Special Reqs.	Groups	Exp. Time (Total)/[Actual Dur.]	Orbit																																																																																																
	1	(COS.ta.100 4326)	(39) HD161897	COS/NUV, ACQ/IMAGE, BOA	MIRRORA				8 Secs (8 Secs) [==>]	[1]																																																																																																
	2	(COS.sp.100 5139)	(39) HD161897	COS/FUV, TIME-TAG, PSA	G130M 1222 A	BUFFER-TIME=51 7; FP-POS=3			617 Secs (617 Secs) [==>]	[1]																																																																																																
	Comments: Note: ETC simulation (for G130M-1291, so as to include Ly-alpha) is for an "extreme" FUV spectrum, scaled to V=7.2 mag, and thus will over-predict count rates for most of the targets (see Observation Description).																																																																																																									
	3	(COS.sp.100 5139)	(39) HD161897	COS/FUV, TIME-TAG, PSA	G130M 1222 A	BUFFER-TIME=51 7; FP-POS=4			617 Secs (617 Secs) [==>]	[1]																																																																																																
Comments: Note: ETC simulation (for G130M-1291, so as to include Ly-alpha) is for an "extreme" FUV spectrum, scaled to V=7.2 mag, and thus will over-predict count rates for most of the targets (see Observation Description).																																																																																																										
4	(COS.sp.100 5139)	(39) HD161897	COS/FUV, TIME-TAG, PSA	G130M 1291 A	BUFFER-TIME=51 7; FP-POS=3			617 Secs (617 Secs) [==>]	[1]																																																																																																	
Comments: Note: ETC simulation (for G130M-1291, so as to include Ly-alpha) is for an "extreme" FUV spectrum, scaled to V=7.2 mag, and thus will over-predict count rates for most of the targets (see Observation Description).																																																																																																										
5	(COS.sp.100 5139)	(39) HD161897	COS/FUV, TIME-TAG, PSA	G130M 1291 A	BUFFER-TIME=51 7; FP-POS=4			617 Secs (617 Secs) [==>]	[1]																																																																																																	
Comments: Note: ETC simulation (for G130M-1291, so as to include Ly-alpha) is for an "extreme" FUV spectrum, scaled to V=7.2 mag, and thus will over-predict count rates for most of the targets (see Observation Description).																																																																																																										

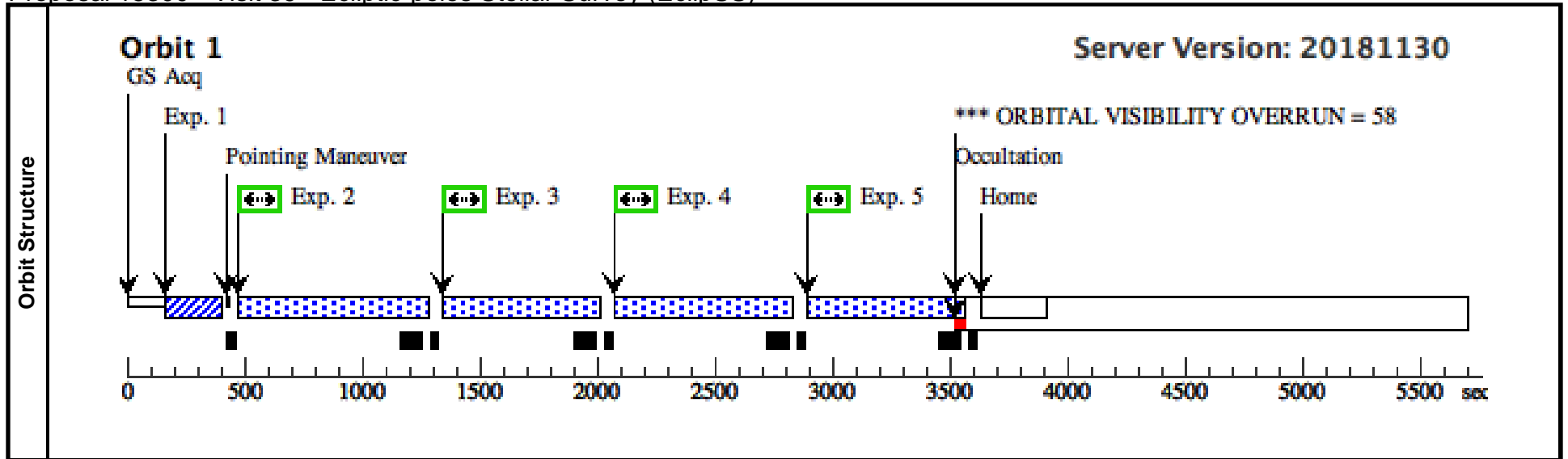

Proposal 15300 - Visit 40 - Ecliptic-poles Stellar Survey (EclipSS)

Thu Dec 13 22:02:08 GMT 2018

Visit	Proposal 15300, Visit 40, scheduling Diagnostic Status: Warning Scientific Instruments: COS/FUV, COS/NUV Special Requirements: (none)										
	(Visit 40) Warning (Form): For the best data quality, it is strongly recommended that the maximum number of allowed FP-POS positions is used when observing at a given COS CENWAVE setting. See full description for details. (Visit 40) Warning (Orbit Planner): ORBITAL VISIBILITY OVERRUN										
Fixed Targets	#	Name	Target Coordinates	Targ. Coord. Corrections	Fluxes	Miscellaneous					
	(40)	HD201651	RA: 21 06 56.3890 (316.7349542d) Dec: +69 40 28.54 (69.67459d) Equinox: J2000	Proper Motion RA: 108.72 mas/yr Proper Motion Dec: 65.27 mas/yr Parallax: 0.03039" Epoch of Position: 2000 Radial Velocity: 0.0 km/sec	V=8.20+/-0.1 sptyp= K0V; (B-V)= 0.74 mag; dist= 32 pc	Reference Frame: ICRS					
Comments: Category=STAR Description=[K V-IV] Extended=NO											
Exposures	#	Label (ETC Run)	Target	Config,Mode,Aperture	Spectral Els.	Opt. Params.	Special Reqs.	Groups	Exp. Time (Total)/[Actual Dur.]	Orbit	
	1	(COS.ta.100 4327)	(40) HD201651	COS/NUV, ACQ/IMAGE, BOA	MIRRORA				12 Secs (12 Secs) [==>]	[1]	
	2	(COS.sp.100 5139)	(40) HD201651	COS/FUV, TIME-TAG, PSA	G130M 1222 A	5; FP-POS=3			605 Secs (605 Secs) [==>]	[1]	
	Comments: Note: ETC simulation (for G130M-1291, so as to include Ly-alpha) is for an "extreme" FUV spectrum, scaled to V=7.2 mag, and thus will over-predict count rates for most of the targets (see Observation Description).										
	3	(COS.sp.100 5139)	(40) HD201651	COS/FUV, TIME-TAG, PSA	G130M 1222 A	5; FP-POS=4			605 Secs (605 Secs) [==>]	[1]	
	Comments: Note: ETC simulation (for G130M-1291, so as to include Ly-alpha) is for an "extreme" FUV spectrum, scaled to V=7.2 mag, and thus will over-predict count rates for most of the targets (see Observation Description).										
4	(COS.sp.100 5139)	(40) HD201651	COS/FUV, TIME-TAG, PSA	G130M 1291 A	5; FP-POS=3			605 Secs (605 Secs) [==>]	[1]		
Comments: Note: ETC simulation (for G130M-1291, so as to include Ly-alpha) is for an "extreme" FUV spectrum, scaled to V=7.2 mag, and thus will over-predict count rates for most of the targets (see Observation Description).											
5	(COS.sp.100 5139)	(40) HD201651	COS/FUV, TIME-TAG, PSA	G130M 1291 A	5; FP-POS=4			605 Secs (605 Secs) [==>]	[1]		
Comments: Note: ETC simulation (for G130M-1291, so as to include Ly-alpha) is for an "extreme" FUV spectrum, scaled to V=7.2 mag, and thus will over-predict count rates for most of the targets (see Observation Description).											

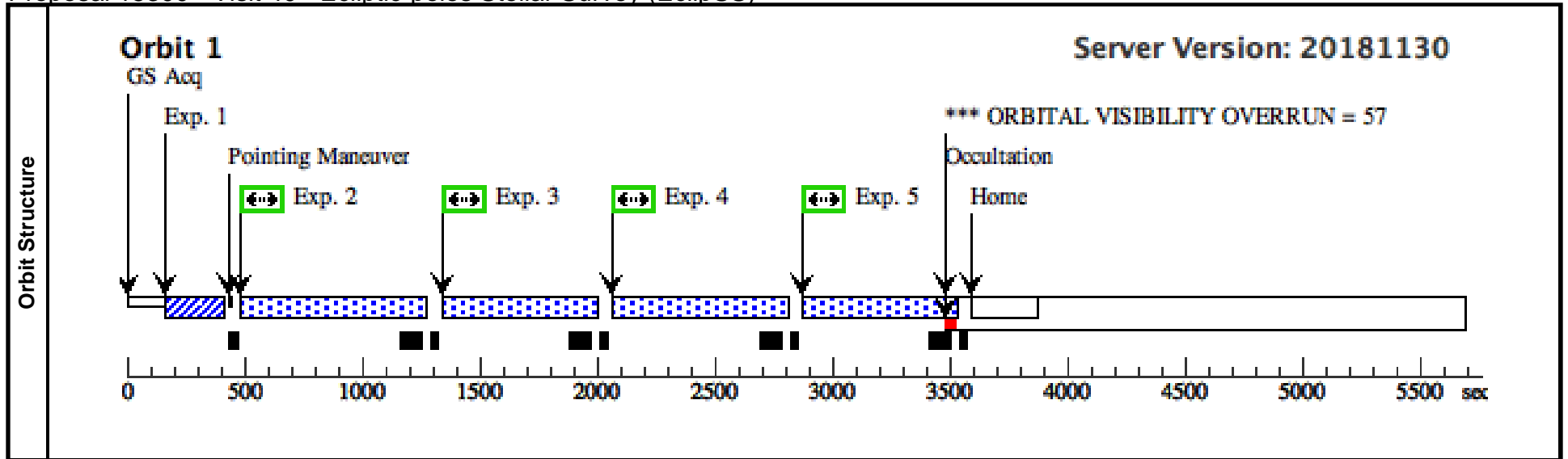

Proposal 15300 - Visit 41 - Ecliptic-poles Stellar Survey (EclipSS)

Thu Dec 13 22:02:08 GMT 2018

Visit	Proposal 15300, Visit 41, scheduled Diagnostic Status: Warning Scientific Instruments: COS/FUV, COS/NUV Special Requirements: (none)										
	(Visit 41) Warning (Form): For the best data quality, it is strongly recommended that the maximum number of allowed FP-POS positions is used when observing at a given COS CENWAVE setting. See full description for details. (Visit 41) Warning (Orbit Planner): ORBITAL VISIBILITY OVERRUN										
Fixed Targets	#	Name	Target Coordinates	Targ. Coord. Corrections	Fluxes	Miscellaneous					
	(41)	HD39194	RA: 05 44 31.9186 (86.1329942d) Dec: -70 08 36.86 (-70.14357d) Equinox: J2000	Proper Motion RA: -309.21 mas/yr Proper Motion Dec: 1238.39 mas/yr Parallax: 0.03861" Epoch of Position: 2000 Radial Velocity: 0.0 km/sec	V=8.08+/-0.1 sptyp= K0V; (B-V)= 0.76 mag; dist= 26 pc	Reference Frame: ICRS					
Comments: Category=STAR Description=[K V-IV] Extended=NO											
Exposures	#	Label (ETC Run)	Target	Config,Mode,Aperture	Spectral Els.	Opt. Params.	Special Reqs.	Groups	Exp. Time (Total)/[Actual Dur.]	Orbit	
	1	(COS.ta.100 4332)	(41) HD39194	COS/NUV, ACQ/IMAGE, BOA	MIRRORA				12 Secs (12 Secs) [==>]	[1]	
	2	(COS.sp.100 5139)	(41) HD39194	COS/FUV, TIME-TAG, PSA	G130M 1222 A	5; FP-POS=3			615 Secs (615 Secs) [==>]	[1]	
	Comments: Note: ETC simulation (for G130M-1291, so as to include Ly-alpha) is for an "extreme" FUV spectrum, scaled to V=7.2 mag, and thus will over-predict count rates for most of the targets (see Observation Description).										
	3	(COS.sp.100 5139)	(41) HD39194	COS/FUV, TIME-TAG, PSA	G130M 1222 A	5; FP-POS=4			615 Secs (615 Secs) [==>]	[1]	
	Comments: Note: ETC simulation (for G130M-1291, so as to include Ly-alpha) is for an "extreme" FUV spectrum, scaled to V=7.2 mag, and thus will over-predict count rates for most of the targets (see Observation Description).										
4	(COS.sp.100 5139)	(41) HD39194	COS/FUV, TIME-TAG, PSA	G130M 1291 A	5; FP-POS=3			615 Secs (615 Secs) [==>]	[1]		
Comments: Note: ETC simulation (for G130M-1291, so as to include Ly-alpha) is for an "extreme" FUV spectrum, scaled to V=7.2 mag, and thus will over-predict count rates for most of the targets (see Observation Description).											
5	(COS.sp.100 5139)	(41) HD39194	COS/FUV, TIME-TAG, PSA	G130M 1291 A	5; FP-POS=4			615 Secs (615 Secs) [==>]	[1]		
Comments: Note: ETC simulation (for G130M-1291, so as to include Ly-alpha) is for an "extreme" FUV spectrum, scaled to V=7.2 mag, and thus will over-predict count rates for most of the targets (see Observation Description).											

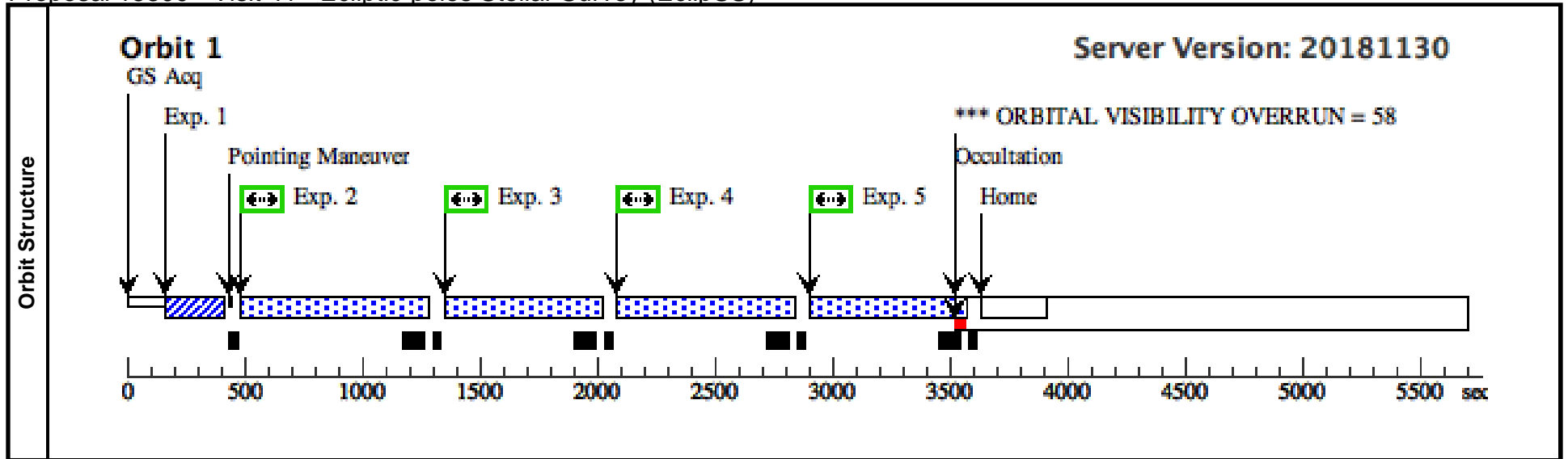

Proposal 15300 - Visit 42 - Ecliptic-poles Stellar Survey (EclipSS)

Thu Dec 13 22:02:08 GMT 2018

Visit	Proposal 15300, Visit 42, completed Diagnostic Status: Warning Scientific Instruments: COS/FUV, COS/NUV Special Requirements: (none)										
	(Visit 42) Warning (Form): For the best data quality, it is strongly recommended that the maximum number of allowed FP-POS positions is used when observing at a given COS CENWAVE setting. See full description for details. (Visit 42) Warning (Orbit Planner): ORBITAL VISIBILITY OVERRUN										
Fixed Targets	#	Name	Target Coordinates	Targ. Coord. Corrections	Fluxes	Miscellaneous					
	(42)	HD51608	RA: 06 54 51.3421 (103.7139254d) Dec: -55 15 33.58 (-55.25933d) Equinox: J2000	Proper Motion RA: -26.45 mas/yr Proper Motion Dec: -160.07 mas/yr Parallax: 0.02871" Epoch of Position: 2000 Radial Velocity: 0.0 km/sec	V=8.17+/-0.1 sptyp= K0V; (B-V)= 0.77 mag; dist= 35 pc	Reference Frame: ICRS					
Comments: Category=STAR Description=[K V-IV] Extended=NO											
Exposures	#	Label (ETC Run)	Target	Config,Mode,Aperture	Spectral Els.	Opt. Params.	Special Reqs.	Groups	Exp. Time (Total)/[Actual Dur.]	Orbit	
	1	(COS.ta.100 4333)	(42) HD51608	COS/NUV, ACQ/IMAGE, BOA	MIRRORA				12 Secs (12 Secs) [==>]	[1]	
	2	(COS.sp.100 5139)	(42) HD51608	COS/FUV, TIME-TAG, PSA	G130M 1222 A	BUFFER-TIME=48 1; FP-POS=3			581 Secs (581 Secs) [==>]	[1]	
	Comments: Note: ETC simulation (for G130M-1291, so as to include Ly-alpha) is for an "extreme" FUV spectrum, scaled to V=7.2 mag, and thus will over-predict count rates for most of the targets (see Observation Description).										
	3	(COS.sp.100 5139)	(42) HD51608	COS/FUV, TIME-TAG, PSA	G130M 1222 A	BUFFER-TIME=48 1; FP-POS=4			581 Secs (581 Secs) [==>]	[1]	
	Comments: Note: ETC simulation (for G130M-1291, so as to include Ly-alpha) is for an "extreme" FUV spectrum, scaled to V=7.2 mag, and thus will over-predict count rates for most of the targets (see Observation Description).										
4	(COS.sp.100 5139)	(42) HD51608	COS/FUV, TIME-TAG, PSA	G130M 1291 A	BUFFER-TIME=48 1; FP-POS=3			581 Secs (581 Secs) [==>]	[1]		
Comments: Note: ETC simulation (for G130M-1291, so as to include Ly-alpha) is for an "extreme" FUV spectrum, scaled to V=7.2 mag, and thus will over-predict count rates for most of the targets (see Observation Description).											
5	(COS.sp.100 5139)	(42) HD51608	COS/FUV, TIME-TAG, PSA	G130M 1291 A	BUFFER-TIME=48 1; FP-POS=4			581 Secs (581 Secs) [==>]	[1]		
Comments: Note: ETC simulation (for G130M-1291, so as to include Ly-alpha) is for an "extreme" FUV spectrum, scaled to V=7.2 mag, and thus will over-predict count rates for most of the targets (see Observation Description).											

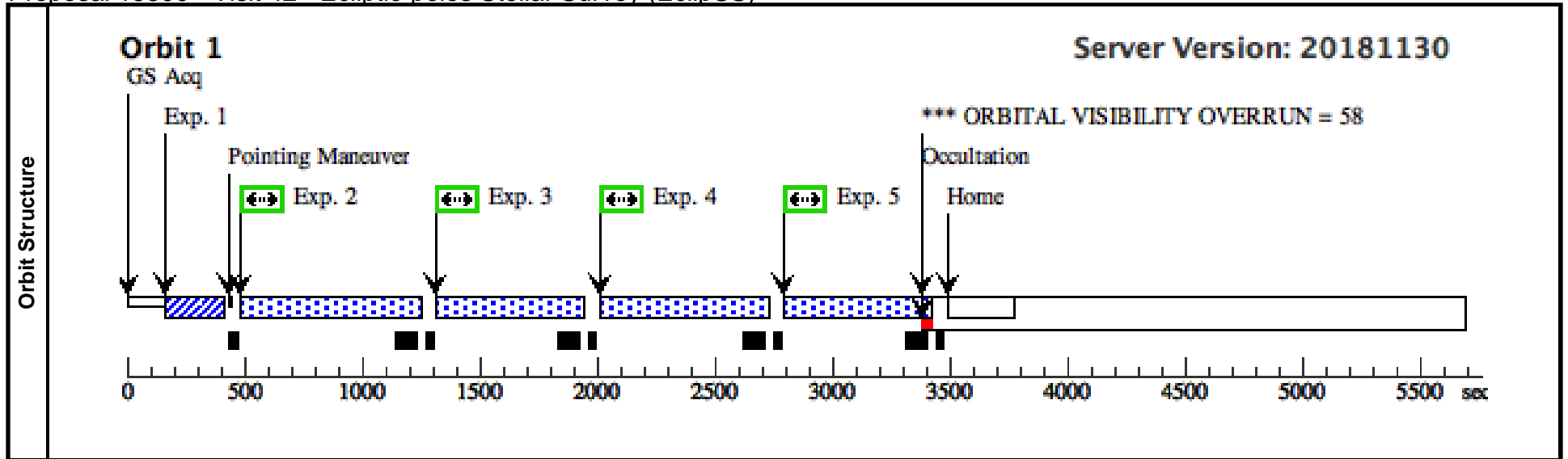

Proposal 15300 - Visit 43 - Ecliptic-poles Stellar Survey (EclipSS)

Thu Dec 13 22:02:08 GMT 2018

Visit	Proposal 15300, Visit 43, scheduled Diagnostic Status: Warning Scientific Instruments: COS/FUV, COS/NUV Special Requirements: (none)																																																																																																									
	(Visit 43) Warning (Form): For the best data quality, it is strongly recommended that the maximum number of allowed FP-POS positions is used when observing at a given COS CENWAVE setting. See full description for details. (Visit 43) Warning (Orbit Planner): ORBITAL VISIBILITY OVERRUN																																																																																																									
Diagnosics																																																																																																										
Fixed Targets	<table border="1"> <thead> <tr> <th>#</th> <th>Name</th> <th>Target Coordinates</th> <th>Targ. Coord. Corrections</th> <th>Fluxes</th> <th>Miscellaneous</th> </tr> </thead> <tbody> <tr> <td>(43)</td> <td>HD151541</td> <td>RA: 16 42 38.5763 (250.6607346d) Dec: +68 06 7.80 (68.10217d) Equinox: J2000</td> <td>Proper Motion RA: -283.07 mas/yr Proper Motion Dec: 426.91 mas/yr Parallax: 0.03997" Epoch of Position: 2000 Radial Velocity: 0.0 km/sec</td> <td>V=7.56+/-0.1 sptyp= K1V; (B-V)= 0.76 mag; dist= 24 pc</td> <td>Reference Frame: ICRS</td> </tr> </tbody> </table>	#	Name	Target Coordinates	Targ. Coord. Corrections	Fluxes	Miscellaneous	(43)	HD151541	RA: 16 42 38.5763 (250.6607346d) Dec: +68 06 7.80 (68.10217d) Equinox: J2000	Proper Motion RA: -283.07 mas/yr Proper Motion Dec: 426.91 mas/yr Parallax: 0.03997" Epoch of Position: 2000 Radial Velocity: 0.0 km/sec	V=7.56+/-0.1 sptyp= K1V; (B-V)= 0.76 mag; dist= 24 pc	Reference Frame: ICRS	Comments: Category=STAR Description=[K V-IV] Extended=NO																																																																																												
	#	Name	Target Coordinates	Targ. Coord. Corrections	Fluxes	Miscellaneous																																																																																																				
(43)	HD151541	RA: 16 42 38.5763 (250.6607346d) Dec: +68 06 7.80 (68.10217d) Equinox: J2000	Proper Motion RA: -283.07 mas/yr Proper Motion Dec: 426.91 mas/yr Parallax: 0.03997" Epoch of Position: 2000 Radial Velocity: 0.0 km/sec	V=7.56+/-0.1 sptyp= K1V; (B-V)= 0.76 mag; dist= 24 pc	Reference Frame: ICRS																																																																																																					
Exposures	<table border="1"> <thead> <tr> <th>#</th> <th>Label (ETC Run)</th> <th>Target</th> <th>Config,Mode,Aperture</th> <th>Spectral Els.</th> <th>Opt. Params.</th> <th>Special Reqs.</th> <th>Groups</th> <th>Exp. Time (Total)/[Actual Dur.]</th> <th>Orbit</th> </tr> </thead> <tbody> <tr> <td>1</td> <td>(COS.ta.100 4334)</td> <td>(43) HD151541</td> <td>COS/NUV, ACQ/IMAGE, BOA</td> <td>MIRRORA</td> <td></td> <td></td> <td></td> <td>8 Secs (8 Secs) [==>]</td> <td>[1]</td> </tr> <tr> <td>2</td> <td>(COS.sp.100 5139)</td> <td>(43) HD151541</td> <td>COS/FUV, TIME-TAG, PSA</td> <td>G130M 1222 A</td> <td>BUFFER-TIME=50 7; FP-POS=3</td> <td></td> <td></td> <td>607 Secs (607 Secs) [==>]</td> <td>[1]</td> </tr> <tr> <td colspan="10"> Comments: Note: ETC simulation (for G130M-1291, so as to include Ly-alpha) is for an "extreme" FUV spectrum, scaled to V=7.2 mag, and thus will over-predict count rates for most of the targets (see Observation Description). </td> </tr> <tr> <td>3</td> <td>(COS.sp.100 5139)</td> <td>(43) HD151541</td> <td>COS/FUV, TIME-TAG, PSA</td> <td>G130M 1222 A</td> <td>BUFFER-TIME=50 7; FP-POS=4</td> <td></td> <td></td> <td>607 Secs (607 Secs) [==>]</td> <td>[1]</td> </tr> <tr> <td colspan="10"> Comments: Note: ETC simulation (for G130M-1291, so as to include Ly-alpha) is for an "extreme" FUV spectrum, scaled to V=7.2 mag, and thus will over-predict count rates for most of the targets (see Observation Description). </td> </tr> <tr> <td>4</td> <td>(COS.sp.100 5139)</td> <td>(43) HD151541</td> <td>COS/FUV, TIME-TAG, PSA</td> <td>G130M 1291 A</td> <td>BUFFER-TIME=50 7; FP-POS=3</td> <td></td> <td></td> <td>607 Secs (607 Secs) [==>]</td> <td>[1]</td> </tr> <tr> <td colspan="10"> Comments: Note: ETC simulation (for G130M-1291, so as to include Ly-alpha) is for an "extreme" FUV spectrum, scaled to V=7.2 mag, and thus will over-predict count rates for most of the targets (see Observation Description). </td> </tr> <tr> <td>5</td> <td>(COS.sp.100 5139)</td> <td>(43) HD151541</td> <td>COS/FUV, TIME-TAG, PSA</td> <td>G130M 1291 A</td> <td>BUFFER-TIME=50 7; FP-POS=4</td> <td></td> <td></td> <td>607 Secs (607 Secs) [==>]</td> <td>[1]</td> </tr> <tr> <td colspan="10"> Comments: Note: ETC simulation (for G130M-1291, so as to include Ly-alpha) is for an "extreme" FUV spectrum, scaled to V=7.2 mag, and thus will over-predict count rates for most of the targets (see Observation Description). </td> </tr> </tbody> </table>	#	Label (ETC Run)	Target	Config,Mode,Aperture	Spectral Els.	Opt. Params.	Special Reqs.	Groups	Exp. Time (Total)/[Actual Dur.]	Orbit	1	(COS.ta.100 4334)	(43) HD151541	COS/NUV, ACQ/IMAGE, BOA	MIRRORA				8 Secs (8 Secs) [==>]	[1]	2	(COS.sp.100 5139)	(43) HD151541	COS/FUV, TIME-TAG, PSA	G130M 1222 A	BUFFER-TIME=50 7; FP-POS=3			607 Secs (607 Secs) [==>]	[1]	Comments: Note: ETC simulation (for G130M-1291, so as to include Ly-alpha) is for an "extreme" FUV spectrum, scaled to V=7.2 mag, and thus will over-predict count rates for most of the targets (see Observation Description).										3	(COS.sp.100 5139)	(43) HD151541	COS/FUV, TIME-TAG, PSA	G130M 1222 A	BUFFER-TIME=50 7; FP-POS=4			607 Secs (607 Secs) [==>]	[1]	Comments: Note: ETC simulation (for G130M-1291, so as to include Ly-alpha) is for an "extreme" FUV spectrum, scaled to V=7.2 mag, and thus will over-predict count rates for most of the targets (see Observation Description).										4	(COS.sp.100 5139)	(43) HD151541	COS/FUV, TIME-TAG, PSA	G130M 1291 A	BUFFER-TIME=50 7; FP-POS=3			607 Secs (607 Secs) [==>]	[1]	Comments: Note: ETC simulation (for G130M-1291, so as to include Ly-alpha) is for an "extreme" FUV spectrum, scaled to V=7.2 mag, and thus will over-predict count rates for most of the targets (see Observation Description).										5	(COS.sp.100 5139)	(43) HD151541	COS/FUV, TIME-TAG, PSA	G130M 1291 A	BUFFER-TIME=50 7; FP-POS=4			607 Secs (607 Secs) [==>]	[1]	Comments: Note: ETC simulation (for G130M-1291, so as to include Ly-alpha) is for an "extreme" FUV spectrum, scaled to V=7.2 mag, and thus will over-predict count rates for most of the targets (see Observation Description).														
	#	Label (ETC Run)	Target	Config,Mode,Aperture	Spectral Els.	Opt. Params.	Special Reqs.	Groups	Exp. Time (Total)/[Actual Dur.]	Orbit																																																																																																
	1	(COS.ta.100 4334)	(43) HD151541	COS/NUV, ACQ/IMAGE, BOA	MIRRORA				8 Secs (8 Secs) [==>]	[1]																																																																																																
	2	(COS.sp.100 5139)	(43) HD151541	COS/FUV, TIME-TAG, PSA	G130M 1222 A	BUFFER-TIME=50 7; FP-POS=3			607 Secs (607 Secs) [==>]	[1]																																																																																																
	Comments: Note: ETC simulation (for G130M-1291, so as to include Ly-alpha) is for an "extreme" FUV spectrum, scaled to V=7.2 mag, and thus will over-predict count rates for most of the targets (see Observation Description).																																																																																																									
	3	(COS.sp.100 5139)	(43) HD151541	COS/FUV, TIME-TAG, PSA	G130M 1222 A	BUFFER-TIME=50 7; FP-POS=4			607 Secs (607 Secs) [==>]	[1]																																																																																																
Comments: Note: ETC simulation (for G130M-1291, so as to include Ly-alpha) is for an "extreme" FUV spectrum, scaled to V=7.2 mag, and thus will over-predict count rates for most of the targets (see Observation Description).																																																																																																										
4	(COS.sp.100 5139)	(43) HD151541	COS/FUV, TIME-TAG, PSA	G130M 1291 A	BUFFER-TIME=50 7; FP-POS=3			607 Secs (607 Secs) [==>]	[1]																																																																																																	
Comments: Note: ETC simulation (for G130M-1291, so as to include Ly-alpha) is for an "extreme" FUV spectrum, scaled to V=7.2 mag, and thus will over-predict count rates for most of the targets (see Observation Description).																																																																																																										
5	(COS.sp.100 5139)	(43) HD151541	COS/FUV, TIME-TAG, PSA	G130M 1291 A	BUFFER-TIME=50 7; FP-POS=4			607 Secs (607 Secs) [==>]	[1]																																																																																																	
Comments: Note: ETC simulation (for G130M-1291, so as to include Ly-alpha) is for an "extreme" FUV spectrum, scaled to V=7.2 mag, and thus will over-predict count rates for most of the targets (see Observation Description).																																																																																																										

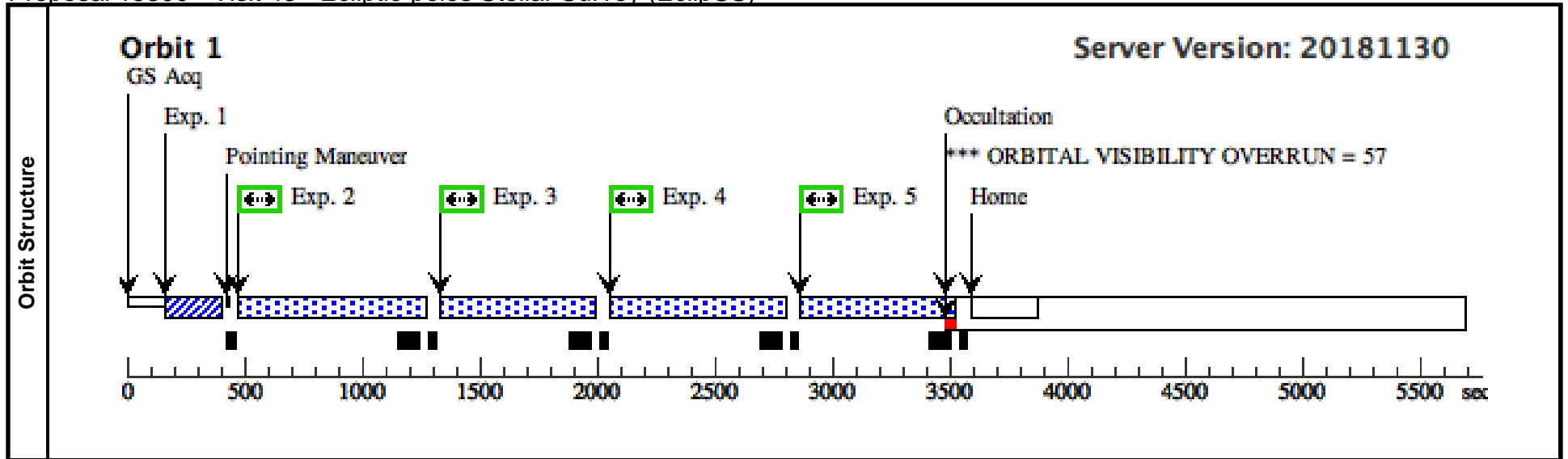

Proposal 15300 - Visit 44 - Ecliptic-poles Stellar Survey (EclipSS)

Thu Dec 13 22:02:09 GMT 2018

Visit	Proposal 15300, Visit 44, scheduled Diagnostic Status: Warning Scientific Instruments: COS/FUV, COS/NUV Special Requirements: (none)										
	(Visit 44) Warning (Form): For the best data quality, it is strongly recommended that the maximum number of allowed FP-POS positions is used when observing at a given COS CENWAVE setting. See full description for details. (Visit 44) Warning (Orbit Planner): ORBITAL VISIBILITY OVERRUN										
Fixed Targets	#	Name	Target Coordinates	Targ. Coord. Corrections	Fluxes	Miscellaneous					
	(44)	HD47252	RA: 06 31 56.7346 (97.9863942d) Dec: -68 42 35.52 (-68.70987d) Equinox: J2000	Proper Motion RA: -56.19 mas/yr Proper Motion Dec: -450.38 mas/yr Parallax: 0.03597" Epoch of Position: 2000	V=8.27+/-0.1 sptyp= K1V; (B-V)= 0.79 mag; dist= 28 pc	Reference Frame: ICRS					
Comments: Category=STAR Description=[K V-IV] Extended=NO											
Exposures	#	Label (ETC Run)	Target	Config,Mode,Aperture	Spectral Els.	Opt. Params.	Special Reqs.	Groups	Exp. Time (Total)/[Actual Dur.]	Orbit	
	1	(COS.ta.100 4335)	(44) HD47252	COS/NUV, ACQ/IMAGE, BOA	MIRRORA				14 Secs (14 Secs) [==>]	[1]	
	2	(COS.sp.100 5139)	(44) HD47252	COS/FUV, TIME-TAG, PSA	G130M 1222 A	4; FP-POS=3			604 Secs (604 Secs) [==>]	[1]	
	Comments: Note: ETC simulation (for G130M-1291, so as to include Ly-alpha) is for an "extreme" FUV spectrum, scaled to V=7.2 mag, and thus will over-predict count rates for most of the targets (see Observation Description).										
	3	(COS.sp.100 5139)	(44) HD47252	COS/FUV, TIME-TAG, PSA	G130M 1222 A	4; FP-POS=4			604 Secs (604 Secs) [==>]	[1]	
	Comments: Note: ETC simulation (for G130M-1291, so as to include Ly-alpha) is for an "extreme" FUV spectrum, scaled to V=7.2 mag, and thus will over-predict count rates for most of the targets (see Observation Description).										
4	(COS.sp.100 5139)	(44) HD47252	COS/FUV, TIME-TAG, PSA	G130M 1291 A	4; FP-POS=3			604 Secs (604 Secs) [==>]	[1]		
Comments: Note: ETC simulation (for G130M-1291, so as to include Ly-alpha) is for an "extreme" FUV spectrum, scaled to V=7.2 mag, and thus will over-predict count rates for most of the targets (see Observation Description).											
5	(COS.sp.100 5139)	(44) HD47252	COS/FUV, TIME-TAG, PSA	G130M 1291 A	4; FP-POS=4			604 Secs (604 Secs) [==>]	[1]		
Comments: Note: ETC simulation (for G130M-1291, so as to include Ly-alpha) is for an "extreme" FUV spectrum, scaled to V=7.2 mag, and thus will over-predict count rates for most of the targets (see Observation Description).											

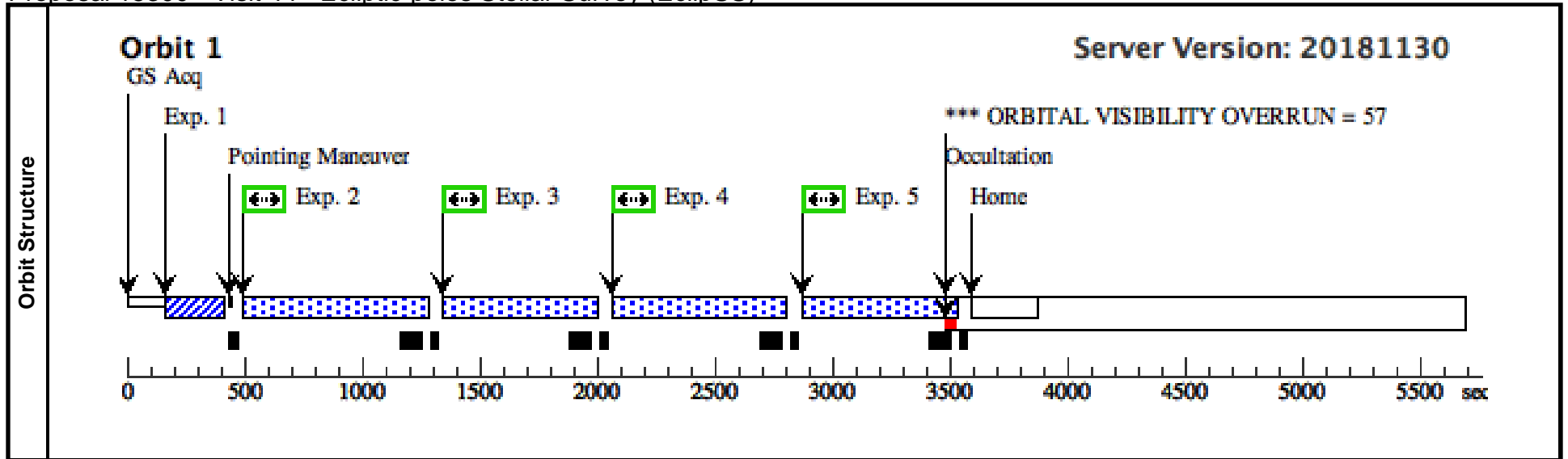

Proposal 15300 - Visit 45 - Ecliptic-poles Stellar Survey (EclipSS)

Thu Dec 13 22:02:09 GMT 2018

Visit	Proposal 15300, Visit 45, completed Diagnostic Status: Warning Scientific Instruments: COS/FUV, COS/NUV Special Requirements: (none)																																																																																																													
	(Visit 45) Warning (Form): For the best data quality, it is strongly recommended that the maximum number of allowed FP-POS positions is used when observing at a given COS CENWAVE setting. See full description for details. (Visit 45) Warning (Orbit Planner): ORBITAL VISIBILITY OVERRUN																																																																																																													
Fixed Targets	<table border="1"> <thead> <tr> <th>#</th> <th>Name</th> <th>Target Coordinates</th> <th>Targ. Coord. Corrections</th> <th>Fluxes</th> <th>Miscellaneous</th> </tr> </thead> <tbody> <tr> <td>(45)</td> <td>HD202123</td> <td>RA: 21 08 40.6571 (317.1694046d) Dec: +73 41 48.51 (73.69681d) Equinox: J2000</td> <td>Proper Motion RA: -323.61 mas/yr Proper Motion Dec: -399.21 mas/yr Parallax: 0.03211" Epoch of Position: 2000 Radial Velocity: 0.0 km/sec</td> <td>V=8.70+/-0.1 sptyp= K1V; (B-V)= 0.82 mag; dist= 32 pc</td> <td>Reference Frame: ICRS</td> </tr> </tbody> </table>						#	Name	Target Coordinates	Targ. Coord. Corrections	Fluxes	Miscellaneous	(45)	HD202123	RA: 21 08 40.6571 (317.1694046d) Dec: +73 41 48.51 (73.69681d) Equinox: J2000	Proper Motion RA: -323.61 mas/yr Proper Motion Dec: -399.21 mas/yr Parallax: 0.03211" Epoch of Position: 2000 Radial Velocity: 0.0 km/sec	V=8.70+/-0.1 sptyp= K1V; (B-V)= 0.82 mag; dist= 32 pc	Reference Frame: ICRS																																																																																												
	#	Name	Target Coordinates	Targ. Coord. Corrections	Fluxes	Miscellaneous																																																																																																								
(45)	HD202123	RA: 21 08 40.6571 (317.1694046d) Dec: +73 41 48.51 (73.69681d) Equinox: J2000	Proper Motion RA: -323.61 mas/yr Proper Motion Dec: -399.21 mas/yr Parallax: 0.03211" Epoch of Position: 2000 Radial Velocity: 0.0 km/sec	V=8.70+/-0.1 sptyp= K1V; (B-V)= 0.82 mag; dist= 32 pc	Reference Frame: ICRS																																																																																																									
Comments: Category=STAR Description=[K V-IV] Extended=NO																																																																																																														
Exposures	<table border="1"> <thead> <tr> <th>#</th> <th>Label (ETC Run)</th> <th>Target</th> <th>Config,Mode,Aperture</th> <th>Spectral Els.</th> <th>Opt. Params.</th> <th>Special Reqs.</th> <th>Groups</th> <th>Exp. Time (Total)/[Actual Dur.]</th> <th>Orbit</th> </tr> </thead> <tbody> <tr> <td>1</td> <td>(COS.ta.100 4337)</td> <td>(45) HD202123</td> <td>COS/NUV, ACQ/IMAGE, BOA</td> <td>MIRRORA</td> <td></td> <td></td> <td></td> <td>38 Secs (38 Secs) [==>]</td> <td>[1]</td> </tr> <tr> <td>2</td> <td>(COS.sp.100 5139)</td> <td>(45) HD202123</td> <td>COS/FUV, TIME-TAG, PSA</td> <td>G130M 1222 A</td> <td>BUFFER-TIME=50 2; FP-POS=3</td> <td></td> <td></td> <td>602 Secs (602 Secs) [==>]</td> <td>[1]</td> </tr> <tr> <td colspan="10"> Comments: Note: ETC simulation (for G130M-1291, so as to include Ly-alpha) is for an "extreme" FUV spectrum, scaled to V=7.2 mag, and thus will over-predict count rates for most of the targets (see Observation Description). </td> </tr> <tr> <td>3</td> <td>(COS.sp.100 5139)</td> <td>(45) HD202123</td> <td>COS/FUV, TIME-TAG, PSA</td> <td>G130M 1222 A</td> <td>BUFFER-TIME=50 2; FP-POS=4</td> <td></td> <td></td> <td>602 Secs (602 Secs) [==>]</td> <td>[1]</td> </tr> <tr> <td colspan="10"> Comments: Note: ETC simulation (for G130M-1291, so as to include Ly-alpha) is for an "extreme" FUV spectrum, scaled to V=7.2 mag, and thus will over-predict count rates for most of the targets (see Observation Description). </td> </tr> <tr> <td>4</td> <td>(COS.sp.100 5139)</td> <td>(45) HD202123</td> <td>COS/FUV, TIME-TAG, PSA</td> <td>G130M 1291 A</td> <td>BUFFER-TIME=50 2; FP-POS=3</td> <td></td> <td></td> <td>602 Secs (602 Secs) [==>]</td> <td>[1]</td> </tr> <tr> <td colspan="10"> Comments: Note: ETC simulation (for G130M-1291, so as to include Ly-alpha) is for an "extreme" FUV spectrum, scaled to V=7.2 mag, and thus will over-predict count rates for most of the targets (see Observation Description). </td> </tr> <tr> <td>5</td> <td>(COS.sp.100 5139)</td> <td>(45) HD202123</td> <td>COS/FUV, TIME-TAG, PSA</td> <td>G130M 1291 A</td> <td>BUFFER-TIME=50 2; FP-POS=4</td> <td></td> <td></td> <td>602 Secs (602 Secs) [==>]</td> <td>[1]</td> </tr> <tr> <td colspan="10"> Comments: Note: ETC simulation (for G130M-1291, so as to include Ly-alpha) is for an "extreme" FUV spectrum, scaled to V=7.2 mag, and thus will over-predict count rates for most of the targets (see Observation Description). </td> </tr> </tbody> </table>										#	Label (ETC Run)	Target	Config,Mode,Aperture	Spectral Els.	Opt. Params.	Special Reqs.	Groups	Exp. Time (Total)/[Actual Dur.]	Orbit	1	(COS.ta.100 4337)	(45) HD202123	COS/NUV, ACQ/IMAGE, BOA	MIRRORA				38 Secs (38 Secs) [==>]	[1]	2	(COS.sp.100 5139)	(45) HD202123	COS/FUV, TIME-TAG, PSA	G130M 1222 A	BUFFER-TIME=50 2; FP-POS=3			602 Secs (602 Secs) [==>]	[1]	Comments: Note: ETC simulation (for G130M-1291, so as to include Ly-alpha) is for an "extreme" FUV spectrum, scaled to V=7.2 mag, and thus will over-predict count rates for most of the targets (see Observation Description).										3	(COS.sp.100 5139)	(45) HD202123	COS/FUV, TIME-TAG, PSA	G130M 1222 A	BUFFER-TIME=50 2; FP-POS=4			602 Secs (602 Secs) [==>]	[1]	Comments: Note: ETC simulation (for G130M-1291, so as to include Ly-alpha) is for an "extreme" FUV spectrum, scaled to V=7.2 mag, and thus will over-predict count rates for most of the targets (see Observation Description).										4	(COS.sp.100 5139)	(45) HD202123	COS/FUV, TIME-TAG, PSA	G130M 1291 A	BUFFER-TIME=50 2; FP-POS=3			602 Secs (602 Secs) [==>]	[1]	Comments: Note: ETC simulation (for G130M-1291, so as to include Ly-alpha) is for an "extreme" FUV spectrum, scaled to V=7.2 mag, and thus will over-predict count rates for most of the targets (see Observation Description).										5	(COS.sp.100 5139)	(45) HD202123	COS/FUV, TIME-TAG, PSA	G130M 1291 A	BUFFER-TIME=50 2; FP-POS=4			602 Secs (602 Secs) [==>]	[1]	Comments: Note: ETC simulation (for G130M-1291, so as to include Ly-alpha) is for an "extreme" FUV spectrum, scaled to V=7.2 mag, and thus will over-predict count rates for most of the targets (see Observation Description).									
	#	Label (ETC Run)	Target	Config,Mode,Aperture	Spectral Els.	Opt. Params.	Special Reqs.	Groups	Exp. Time (Total)/[Actual Dur.]	Orbit																																																																																																				
	1	(COS.ta.100 4337)	(45) HD202123	COS/NUV, ACQ/IMAGE, BOA	MIRRORA				38 Secs (38 Secs) [==>]	[1]																																																																																																				
	2	(COS.sp.100 5139)	(45) HD202123	COS/FUV, TIME-TAG, PSA	G130M 1222 A	BUFFER-TIME=50 2; FP-POS=3			602 Secs (602 Secs) [==>]	[1]																																																																																																				
	Comments: Note: ETC simulation (for G130M-1291, so as to include Ly-alpha) is for an "extreme" FUV spectrum, scaled to V=7.2 mag, and thus will over-predict count rates for most of the targets (see Observation Description).																																																																																																													
	3	(COS.sp.100 5139)	(45) HD202123	COS/FUV, TIME-TAG, PSA	G130M 1222 A	BUFFER-TIME=50 2; FP-POS=4			602 Secs (602 Secs) [==>]	[1]																																																																																																				
Comments: Note: ETC simulation (for G130M-1291, so as to include Ly-alpha) is for an "extreme" FUV spectrum, scaled to V=7.2 mag, and thus will over-predict count rates for most of the targets (see Observation Description).																																																																																																														
4	(COS.sp.100 5139)	(45) HD202123	COS/FUV, TIME-TAG, PSA	G130M 1291 A	BUFFER-TIME=50 2; FP-POS=3			602 Secs (602 Secs) [==>]	[1]																																																																																																					
Comments: Note: ETC simulation (for G130M-1291, so as to include Ly-alpha) is for an "extreme" FUV spectrum, scaled to V=7.2 mag, and thus will over-predict count rates for most of the targets (see Observation Description).																																																																																																														
5	(COS.sp.100 5139)	(45) HD202123	COS/FUV, TIME-TAG, PSA	G130M 1291 A	BUFFER-TIME=50 2; FP-POS=4			602 Secs (602 Secs) [==>]	[1]																																																																																																					
Comments: Note: ETC simulation (for G130M-1291, so as to include Ly-alpha) is for an "extreme" FUV spectrum, scaled to V=7.2 mag, and thus will over-predict count rates for most of the targets (see Observation Description).																																																																																																														

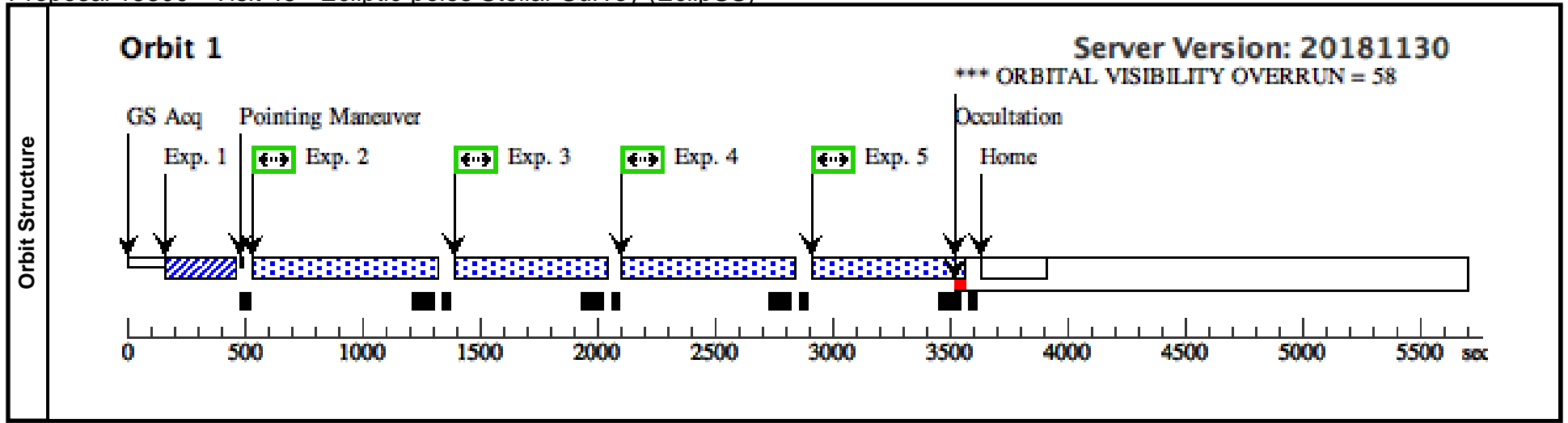

Proposal 15300 - Visit 46 - Ecliptic-poles Stellar Survey (EclipSS)

Thu Dec 13 22:02:09 GMT 2018

Visit	Proposal 15300, Visit 46, completed Diagnostic Status: Warning Scientific Instruments: COS/FUV, COS/NUV Special Requirements: ORIENT 281D TO 341 D; ORIENT 101D TO 161 D <i>Comments: AB 0.5" dHp=3.7 PA=176; ORIENT to separate fainter secondary from primary spectrum</i>																																																																																																									
	(Visit 46) Warning (Form): For the best data quality, it is strongly recommended that the maximum number of allowed FP-POS positions is used when observing at a given COS CENWAVE setting. See full description for details. (Visit 46) Warning (Orbit Planner): ORBITAL VISIBILITY OVERRUN																																																																																																									
Diagnosics																																																																																																										
Fixed Targets	<table border="1"> <thead> <tr> <th>#</th> <th>Name</th> <th>Target Coordinates</th> <th>Targ. Coord. Corrections</th> <th>Fluxes</th> <th>Miscellaneous</th> </tr> </thead> <tbody> <tr> <td>(46)</td> <td>HD41004</td> <td>RA: 05 59 49.6493 (89.9568721d) Dec: -48 14 22.89 (-48.23969d) Equinox: J2000</td> <td>Proper Motion RA: -42.39 mas/yr Proper Motion Dec: 65.58 mas/yr Parallax: 0.02453" Epoch of Position: 2000 Radial Velocity: 0.0 km/sec</td> <td>V=8.65+/-0.1 sptyp= K1V; (B-V)= 0.84 mag; dist= 37 pc</td> <td>Reference Frame: ICRS</td> </tr> </tbody> </table>	#	Name	Target Coordinates	Targ. Coord. Corrections	Fluxes	Miscellaneous	(46)	HD41004	RA: 05 59 49.6493 (89.9568721d) Dec: -48 14 22.89 (-48.23969d) Equinox: J2000	Proper Motion RA: -42.39 mas/yr Proper Motion Dec: 65.58 mas/yr Parallax: 0.02453" Epoch of Position: 2000 Radial Velocity: 0.0 km/sec	V=8.65+/-0.1 sptyp= K1V; (B-V)= 0.84 mag; dist= 37 pc	Reference Frame: ICRS	<i>Comments:</i> Category=STAR Description=[K V-IV] Extended=NO																																																																																												
	#	Name	Target Coordinates	Targ. Coord. Corrections	Fluxes	Miscellaneous																																																																																																				
(46)	HD41004	RA: 05 59 49.6493 (89.9568721d) Dec: -48 14 22.89 (-48.23969d) Equinox: J2000	Proper Motion RA: -42.39 mas/yr Proper Motion Dec: 65.58 mas/yr Parallax: 0.02453" Epoch of Position: 2000 Radial Velocity: 0.0 km/sec	V=8.65+/-0.1 sptyp= K1V; (B-V)= 0.84 mag; dist= 37 pc	Reference Frame: ICRS																																																																																																					
Exposures	<table border="1"> <thead> <tr> <th>#</th> <th>Label (ETC Run)</th> <th>Target</th> <th>Config,Mode,Aperture</th> <th>Spectral Els.</th> <th>Opt. Params.</th> <th>Special Reqs.</th> <th>Groups</th> <th>Exp. Time (Total)/[Actual Dur.]</th> <th>Orbit</th> </tr> </thead> <tbody> <tr> <td>1</td> <td>(COS.ta.100 4338)</td> <td>(46) HD41004</td> <td>COS/NUV, ACQ/IMAGE, BOA</td> <td>MIRRORA</td> <td></td> <td></td> <td></td> <td>36 Secs (36 Secs) [==>]</td> <td>[1]</td> </tr> <tr> <td>2</td> <td>(COS.sp.100 5139)</td> <td>(46) HD41004</td> <td>COS/FUV, TIME-TAG, PSA</td> <td>G130M 1222 A</td> <td>BUFFER-TIME=43 6; FP-POS=3</td> <td></td> <td></td> <td>536 Secs (536 Secs) [==>]</td> <td>[1]</td> </tr> <tr> <td colspan="10"><i>Comments: Note: ETC simulation (for G130M-1291, so as to include Ly-alpha) is for an "extreme" FUV spectrum, scaled to V=7.2 mag, and thus will over-predict count rates for most of the targets (see Observation Description).</i></td> </tr> <tr> <td>3</td> <td>(COS.sp.100 5139)</td> <td>(46) HD41004</td> <td>COS/FUV, TIME-TAG, PSA</td> <td>G130M 1222 A</td> <td>BUFFER-TIME=43 6; FP-POS=4</td> <td></td> <td></td> <td>536 Secs (536 Secs) [==>]</td> <td>[1]</td> </tr> <tr> <td colspan="10"><i>Comments: Note: ETC simulation (for G130M-1291, so as to include Ly-alpha) is for an "extreme" FUV spectrum, scaled to V=7.2 mag, and thus will over-predict count rates for most of the targets (see Observation Description).</i></td> </tr> <tr> <td>4</td> <td>(COS.sp.100 5139)</td> <td>(46) HD41004</td> <td>COS/FUV, TIME-TAG, PSA</td> <td>G130M 1291 A</td> <td>BUFFER-TIME=43 6; FP-POS=3</td> <td></td> <td></td> <td>536 Secs (536 Secs) [==>]</td> <td>[1]</td> </tr> <tr> <td colspan="10"><i>Comments: Note: ETC simulation (for G130M-1291, so as to include Ly-alpha) is for an "extreme" FUV spectrum, scaled to V=7.2 mag, and thus will over-predict count rates for most of the targets (see Observation Description).</i></td> </tr> <tr> <td>5</td> <td>(COS.sp.100 5139)</td> <td>(46) HD41004</td> <td>COS/FUV, TIME-TAG, PSA</td> <td>G130M 1291 A</td> <td>BUFFER-TIME=43 6; FP-POS=4</td> <td></td> <td></td> <td>536 Secs (536 Secs) [==>]</td> <td>[1]</td> </tr> <tr> <td colspan="10"><i>Comments: Note: ETC simulation (for G130M-1291, so as to include Ly-alpha) is for an "extreme" FUV spectrum, scaled to V=7.2 mag, and thus will over-predict count rates for most of the targets (see Observation Description).</i></td> </tr> </tbody> </table>	#	Label (ETC Run)	Target	Config,Mode,Aperture	Spectral Els.	Opt. Params.	Special Reqs.	Groups	Exp. Time (Total)/[Actual Dur.]	Orbit	1	(COS.ta.100 4338)	(46) HD41004	COS/NUV, ACQ/IMAGE, BOA	MIRRORA				36 Secs (36 Secs) [==>]	[1]	2	(COS.sp.100 5139)	(46) HD41004	COS/FUV, TIME-TAG, PSA	G130M 1222 A	BUFFER-TIME=43 6; FP-POS=3			536 Secs (536 Secs) [==>]	[1]	<i>Comments: Note: ETC simulation (for G130M-1291, so as to include Ly-alpha) is for an "extreme" FUV spectrum, scaled to V=7.2 mag, and thus will over-predict count rates for most of the targets (see Observation Description).</i>										3	(COS.sp.100 5139)	(46) HD41004	COS/FUV, TIME-TAG, PSA	G130M 1222 A	BUFFER-TIME=43 6; FP-POS=4			536 Secs (536 Secs) [==>]	[1]	<i>Comments: Note: ETC simulation (for G130M-1291, so as to include Ly-alpha) is for an "extreme" FUV spectrum, scaled to V=7.2 mag, and thus will over-predict count rates for most of the targets (see Observation Description).</i>										4	(COS.sp.100 5139)	(46) HD41004	COS/FUV, TIME-TAG, PSA	G130M 1291 A	BUFFER-TIME=43 6; FP-POS=3			536 Secs (536 Secs) [==>]	[1]	<i>Comments: Note: ETC simulation (for G130M-1291, so as to include Ly-alpha) is for an "extreme" FUV spectrum, scaled to V=7.2 mag, and thus will over-predict count rates for most of the targets (see Observation Description).</i>										5	(COS.sp.100 5139)	(46) HD41004	COS/FUV, TIME-TAG, PSA	G130M 1291 A	BUFFER-TIME=43 6; FP-POS=4			536 Secs (536 Secs) [==>]	[1]	<i>Comments: Note: ETC simulation (for G130M-1291, so as to include Ly-alpha) is for an "extreme" FUV spectrum, scaled to V=7.2 mag, and thus will over-predict count rates for most of the targets (see Observation Description).</i>														
	#	Label (ETC Run)	Target	Config,Mode,Aperture	Spectral Els.	Opt. Params.	Special Reqs.	Groups	Exp. Time (Total)/[Actual Dur.]	Orbit																																																																																																
	1	(COS.ta.100 4338)	(46) HD41004	COS/NUV, ACQ/IMAGE, BOA	MIRRORA				36 Secs (36 Secs) [==>]	[1]																																																																																																
	2	(COS.sp.100 5139)	(46) HD41004	COS/FUV, TIME-TAG, PSA	G130M 1222 A	BUFFER-TIME=43 6; FP-POS=3			536 Secs (536 Secs) [==>]	[1]																																																																																																
	<i>Comments: Note: ETC simulation (for G130M-1291, so as to include Ly-alpha) is for an "extreme" FUV spectrum, scaled to V=7.2 mag, and thus will over-predict count rates for most of the targets (see Observation Description).</i>																																																																																																									
	3	(COS.sp.100 5139)	(46) HD41004	COS/FUV, TIME-TAG, PSA	G130M 1222 A	BUFFER-TIME=43 6; FP-POS=4			536 Secs (536 Secs) [==>]	[1]																																																																																																
<i>Comments: Note: ETC simulation (for G130M-1291, so as to include Ly-alpha) is for an "extreme" FUV spectrum, scaled to V=7.2 mag, and thus will over-predict count rates for most of the targets (see Observation Description).</i>																																																																																																										
4	(COS.sp.100 5139)	(46) HD41004	COS/FUV, TIME-TAG, PSA	G130M 1291 A	BUFFER-TIME=43 6; FP-POS=3			536 Secs (536 Secs) [==>]	[1]																																																																																																	
<i>Comments: Note: ETC simulation (for G130M-1291, so as to include Ly-alpha) is for an "extreme" FUV spectrum, scaled to V=7.2 mag, and thus will over-predict count rates for most of the targets (see Observation Description).</i>																																																																																																										
5	(COS.sp.100 5139)	(46) HD41004	COS/FUV, TIME-TAG, PSA	G130M 1291 A	BUFFER-TIME=43 6; FP-POS=4			536 Secs (536 Secs) [==>]	[1]																																																																																																	
<i>Comments: Note: ETC simulation (for G130M-1291, so as to include Ly-alpha) is for an "extreme" FUV spectrum, scaled to V=7.2 mag, and thus will over-predict count rates for most of the targets (see Observation Description).</i>																																																																																																										

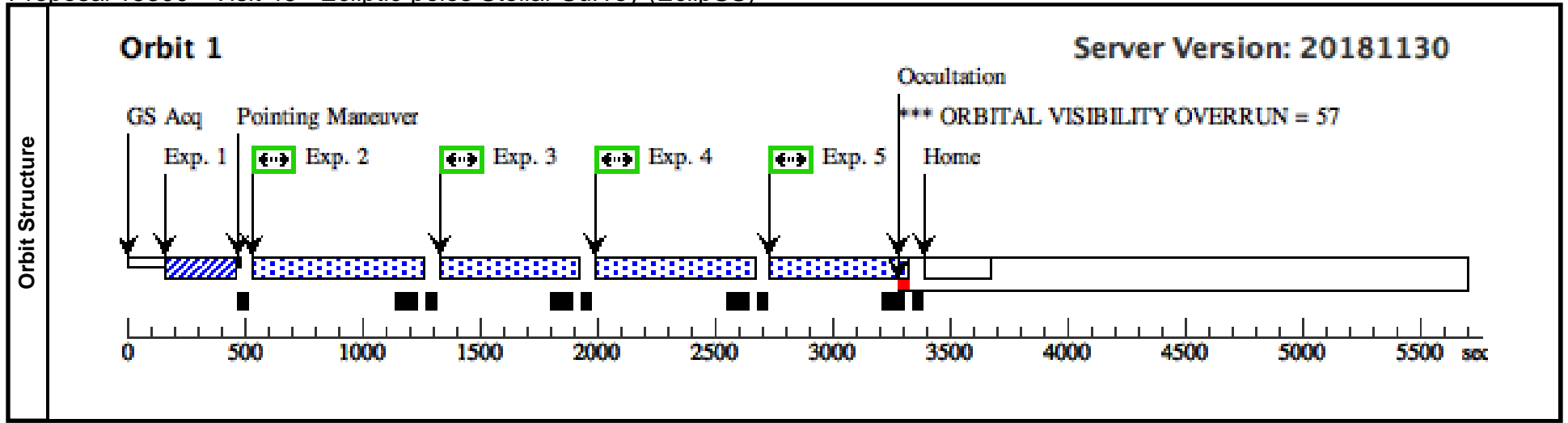

Proposal 15300 - Visit 47 - Ecliptic-poles Stellar Survey (EclipSS)

Thu Dec 13 22:02:09 GMT 2018

Visit	Proposal 15300, Visit 47, completed Diagnostic Status: Warning Scientific Instruments: COS/FUV, COS/NUV Special Requirements: (none)										
	(Visit 47) Warning (Form): For the best data quality, it is strongly recommended that the maximum number of allowed FP-POS positions is used when observing at a given COS CENWAVE setting. See full description for details. (Visit 47) Warning (Orbit Planner): ORBITAL VISIBILITY OVERRUN										
Fixed Targets	#	Name	Target Coordinates	Targ. Coord. Corrections	Fluxes	Miscellaneous					
	(47)	HD42286	RA: 06 06 3.5049 (91.5146038d) Dec: -59 32 35.45 (-59.54318d) Equinox: J2000	Proper Motion RA: -224.75 mas/yr Proper Motion Dec: -743.02 mas/yr Parallax: 0.03649" Epoch of Position: 2000 Radial Velocity: 0.0 km/sec	V=8.47+/-0.1 sptyp= K1V; (B-V)= 0.84 mag; dist= 25 pc	Reference Frame: ICRS					
Comments: Category=STAR Description=[K V-IV] Extended=NO											
Exposures	#	Label (ETC Run)	Target	Config,Mode,Aperture	Spectral Els.	Opt. Params.	Special Reqs.	Groups	Exp. Time (Total)/[Actual Dur.]	Orbit	
	1	(COS.ta.100 4339)	(47) HD42286	COS/NUV, ACQ/IMAGE, BOA	MIRRORA				32 Secs (32 Secs) [==>]	[1]	
	2	(COS.sp.100 5139)	(47) HD42286	COS/FUV, TIME-TAG, PSA	G130M 1222 A	BUFFER-TIME=47 1; FP-POS=3			571 Secs (571 Secs) [==>]	[1]	
	Comments: Note: ETC simulation (for G130M-1291, so as to include Ly-alpha) is for an "extreme" FUV spectrum, scaled to V=7.2 mag, and thus will over-predict count rates for most of the targets (see Observation Description).										
	3	(COS.sp.100 5139)	(47) HD42286	COS/FUV, TIME-TAG, PSA	G130M 1222 A	BUFFER-TIME=47 1; FP-POS=4			571 Secs (571 Secs) [==>]	[1]	
	Comments: Note: ETC simulation (for G130M-1291, so as to include Ly-alpha) is for an "extreme" FUV spectrum, scaled to V=7.2 mag, and thus will over-predict count rates for most of the targets (see Observation Description).										
4	(COS.sp.100 5139)	(47) HD42286	COS/FUV, TIME-TAG, PSA	G130M 1291 A	BUFFER-TIME=47 1; FP-POS=3			571 Secs (571 Secs) [==>]	[1]		
Comments: Note: ETC simulation (for G130M-1291, so as to include Ly-alpha) is for an "extreme" FUV spectrum, scaled to V=7.2 mag, and thus will over-predict count rates for most of the targets (see Observation Description).											
5	(COS.sp.100 5139)	(47) HD42286	COS/FUV, TIME-TAG, PSA	G130M 1291 A	BUFFER-TIME=47 1; FP-POS=4			571 Secs (571 Secs) [==>]	[1]		
Comments: Note: ETC simulation (for G130M-1291, so as to include Ly-alpha) is for an "extreme" FUV spectrum, scaled to V=7.2 mag, and thus will over-predict count rates for most of the targets (see Observation Description).											

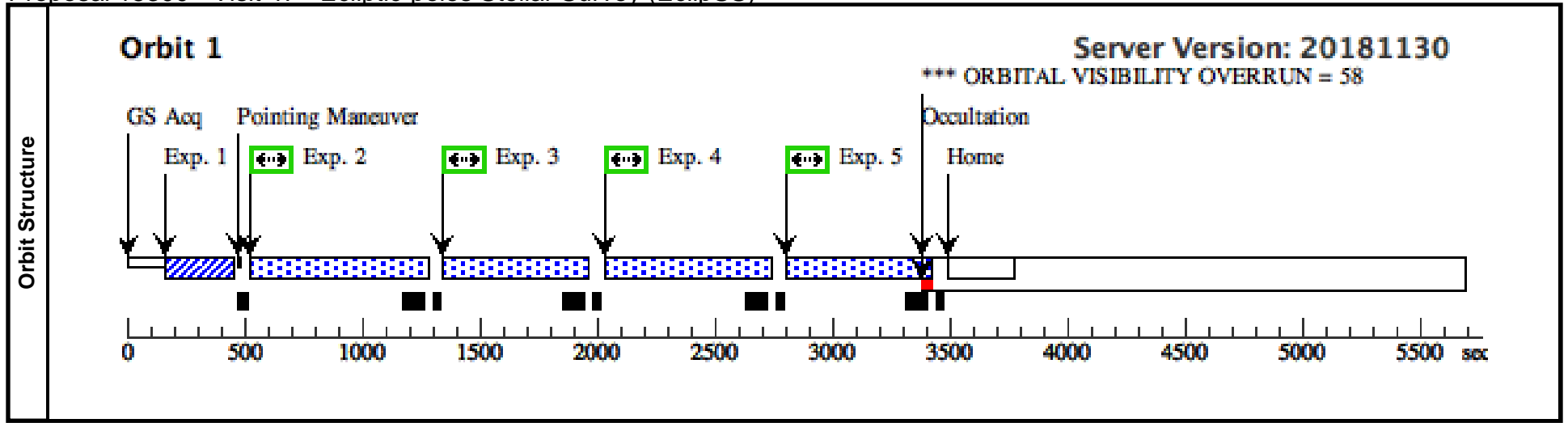

Proposal 15300 - Visit 48 - Ecliptic-poles Stellar Survey (EclipSS)

Thu Dec 13 22:02:09 GMT 2018

Visit	Proposal 15300, Visit 48, scheduling Diagnostic Status: Warning Scientific Instruments: COS/FUV, COS/NUV Special Requirements: (none)																																																																																																									
	(Visit 48) Warning (Form): For the best data quality, it is strongly recommended that the maximum number of allowed FP-POS positions is used when observing at a given COS CENWAVE setting. See full description for details. (Visit 48) Warning (Orbit Planner): ORBITAL VISIBILITY OVERRUN																																																																																																									
Diagnosics																																																																																																										
Fixed Targets	<table border="1"> <thead> <tr> <th>#</th> <th>Name</th> <th>Target Coordinates</th> <th>Targ. Coord. Corrections</th> <th>Fluxes</th> <th>Miscellaneous</th> </tr> </thead> <tbody> <tr> <td>(48)</td> <td>HD38459</td> <td>RA: 05 43 26.4556 (85.8602317d) Dec: -47 49 22.71 (-47.82297d) Equinox: J2000</td> <td>Proper Motion RA: 51.65 mas/yr Proper Motion Dec: 214.27 mas/yr Parallax: 0.02834" Epoch of Position: 2000 Radial Velocity: 0.0 km/sec</td> <td>V=8.50+/-0.1 sptyp= K1V; (B-V)= 0.87 mag; dist= 37 pc</td> <td>Reference Frame: ICRS</td> </tr> </tbody> </table>	#	Name	Target Coordinates	Targ. Coord. Corrections	Fluxes	Miscellaneous	(48)	HD38459	RA: 05 43 26.4556 (85.8602317d) Dec: -47 49 22.71 (-47.82297d) Equinox: J2000	Proper Motion RA: 51.65 mas/yr Proper Motion Dec: 214.27 mas/yr Parallax: 0.02834" Epoch of Position: 2000 Radial Velocity: 0.0 km/sec	V=8.50+/-0.1 sptyp= K1V; (B-V)= 0.87 mag; dist= 37 pc	Reference Frame: ICRS	Comments: Category=STAR Description=[K V-IV] Extended=NO																																																																																												
	#	Name	Target Coordinates	Targ. Coord. Corrections	Fluxes	Miscellaneous																																																																																																				
(48)	HD38459	RA: 05 43 26.4556 (85.8602317d) Dec: -47 49 22.71 (-47.82297d) Equinox: J2000	Proper Motion RA: 51.65 mas/yr Proper Motion Dec: 214.27 mas/yr Parallax: 0.02834" Epoch of Position: 2000 Radial Velocity: 0.0 km/sec	V=8.50+/-0.1 sptyp= K1V; (B-V)= 0.87 mag; dist= 37 pc	Reference Frame: ICRS																																																																																																					
Exposures	<table border="1"> <thead> <tr> <th>#</th> <th>Label (ETC Run)</th> <th>Target</th> <th>Config,Mode,Aperture</th> <th>Spectral Els.</th> <th>Opt. Params.</th> <th>Special Reqs.</th> <th>Groups</th> <th>Exp. Time (Total)/[Actual Dur.]</th> <th>Orbit</th> </tr> </thead> <tbody> <tr> <td>1</td> <td>(COS.ta.100 4340)</td> <td>(48) HD38459</td> <td>COS/NUV, ACQ/IMAGE, BOA</td> <td>MIRRORA</td> <td></td> <td></td> <td></td> <td>32 Secs (32 Secs) [==>]</td> <td>[1]</td> </tr> <tr> <td>2</td> <td>(COS.sp.100 5139)</td> <td>(48) HD38459</td> <td>COS/FUV, TIME-TAG, PSA</td> <td>G130M 1222 A</td> <td>BUFFER-TIME=43 8; FP-POS=3</td> <td></td> <td></td> <td>538 Secs (538 Secs) [==>]</td> <td>[1]</td> </tr> <tr> <td colspan="10"> Comments: Note: ETC simulation (for G130M-1291, so as to include Ly-alpha) is for an "extreme" FUV spectrum, scaled to V=7.2 mag, and thus will over-predict count rates for most of the targets (see Observation Description). </td> </tr> <tr> <td>3</td> <td>(COS.sp.100 5139)</td> <td>(48) HD38459</td> <td>COS/FUV, TIME-TAG, PSA</td> <td>G130M 1222 A</td> <td>BUFFER-TIME=43 8; FP-POS=4</td> <td></td> <td></td> <td>538 Secs (538 Secs) [==>]</td> <td>[1]</td> </tr> <tr> <td colspan="10"> Comments: Note: ETC simulation (for G130M-1291, so as to include Ly-alpha) is for an "extreme" FUV spectrum, scaled to V=7.2 mag, and thus will over-predict count rates for most of the targets (see Observation Description). </td> </tr> <tr> <td>4</td> <td>(COS.sp.100 5139)</td> <td>(48) HD38459</td> <td>COS/FUV, TIME-TAG, PSA</td> <td>G130M 1291 A</td> <td>BUFFER-TIME=43 8; FP-POS=3</td> <td></td> <td></td> <td>538 Secs (538 Secs) [==>]</td> <td>[1]</td> </tr> <tr> <td colspan="10"> Comments: Note: ETC simulation (for G130M-1291, so as to include Ly-alpha) is for an "extreme" FUV spectrum, scaled to V=7.2 mag, and thus will over-predict count rates for most of the targets (see Observation Description). </td> </tr> <tr> <td>5</td> <td>(COS.sp.100 5139)</td> <td>(48) HD38459</td> <td>COS/FUV, TIME-TAG, PSA</td> <td>G130M 1291 A</td> <td>BUFFER-TIME=43 8; FP-POS=4</td> <td></td> <td></td> <td>538 Secs (538 Secs) [==>]</td> <td>[1]</td> </tr> <tr> <td colspan="10"> Comments: Note: ETC simulation (for G130M-1291, so as to include Ly-alpha) is for an "extreme" FUV spectrum, scaled to V=7.2 mag, and thus will over-predict count rates for most of the targets (see Observation Description). </td> </tr> </tbody> </table>	#	Label (ETC Run)	Target	Config,Mode,Aperture	Spectral Els.	Opt. Params.	Special Reqs.	Groups	Exp. Time (Total)/[Actual Dur.]	Orbit	1	(COS.ta.100 4340)	(48) HD38459	COS/NUV, ACQ/IMAGE, BOA	MIRRORA				32 Secs (32 Secs) [==>]	[1]	2	(COS.sp.100 5139)	(48) HD38459	COS/FUV, TIME-TAG, PSA	G130M 1222 A	BUFFER-TIME=43 8; FP-POS=3			538 Secs (538 Secs) [==>]	[1]	Comments: Note: ETC simulation (for G130M-1291, so as to include Ly-alpha) is for an "extreme" FUV spectrum, scaled to V=7.2 mag, and thus will over-predict count rates for most of the targets (see Observation Description).										3	(COS.sp.100 5139)	(48) HD38459	COS/FUV, TIME-TAG, PSA	G130M 1222 A	BUFFER-TIME=43 8; FP-POS=4			538 Secs (538 Secs) [==>]	[1]	Comments: Note: ETC simulation (for G130M-1291, so as to include Ly-alpha) is for an "extreme" FUV spectrum, scaled to V=7.2 mag, and thus will over-predict count rates for most of the targets (see Observation Description).										4	(COS.sp.100 5139)	(48) HD38459	COS/FUV, TIME-TAG, PSA	G130M 1291 A	BUFFER-TIME=43 8; FP-POS=3			538 Secs (538 Secs) [==>]	[1]	Comments: Note: ETC simulation (for G130M-1291, so as to include Ly-alpha) is for an "extreme" FUV spectrum, scaled to V=7.2 mag, and thus will over-predict count rates for most of the targets (see Observation Description).										5	(COS.sp.100 5139)	(48) HD38459	COS/FUV, TIME-TAG, PSA	G130M 1291 A	BUFFER-TIME=43 8; FP-POS=4			538 Secs (538 Secs) [==>]	[1]	Comments: Note: ETC simulation (for G130M-1291, so as to include Ly-alpha) is for an "extreme" FUV spectrum, scaled to V=7.2 mag, and thus will over-predict count rates for most of the targets (see Observation Description).														
	#	Label (ETC Run)	Target	Config,Mode,Aperture	Spectral Els.	Opt. Params.	Special Reqs.	Groups	Exp. Time (Total)/[Actual Dur.]	Orbit																																																																																																
	1	(COS.ta.100 4340)	(48) HD38459	COS/NUV, ACQ/IMAGE, BOA	MIRRORA				32 Secs (32 Secs) [==>]	[1]																																																																																																
	2	(COS.sp.100 5139)	(48) HD38459	COS/FUV, TIME-TAG, PSA	G130M 1222 A	BUFFER-TIME=43 8; FP-POS=3			538 Secs (538 Secs) [==>]	[1]																																																																																																
	Comments: Note: ETC simulation (for G130M-1291, so as to include Ly-alpha) is for an "extreme" FUV spectrum, scaled to V=7.2 mag, and thus will over-predict count rates for most of the targets (see Observation Description).																																																																																																									
	3	(COS.sp.100 5139)	(48) HD38459	COS/FUV, TIME-TAG, PSA	G130M 1222 A	BUFFER-TIME=43 8; FP-POS=4			538 Secs (538 Secs) [==>]	[1]																																																																																																
Comments: Note: ETC simulation (for G130M-1291, so as to include Ly-alpha) is for an "extreme" FUV spectrum, scaled to V=7.2 mag, and thus will over-predict count rates for most of the targets (see Observation Description).																																																																																																										
4	(COS.sp.100 5139)	(48) HD38459	COS/FUV, TIME-TAG, PSA	G130M 1291 A	BUFFER-TIME=43 8; FP-POS=3			538 Secs (538 Secs) [==>]	[1]																																																																																																	
Comments: Note: ETC simulation (for G130M-1291, so as to include Ly-alpha) is for an "extreme" FUV spectrum, scaled to V=7.2 mag, and thus will over-predict count rates for most of the targets (see Observation Description).																																																																																																										
5	(COS.sp.100 5139)	(48) HD38459	COS/FUV, TIME-TAG, PSA	G130M 1291 A	BUFFER-TIME=43 8; FP-POS=4			538 Secs (538 Secs) [==>]	[1]																																																																																																	
Comments: Note: ETC simulation (for G130M-1291, so as to include Ly-alpha) is for an "extreme" FUV spectrum, scaled to V=7.2 mag, and thus will over-predict count rates for most of the targets (see Observation Description).																																																																																																										

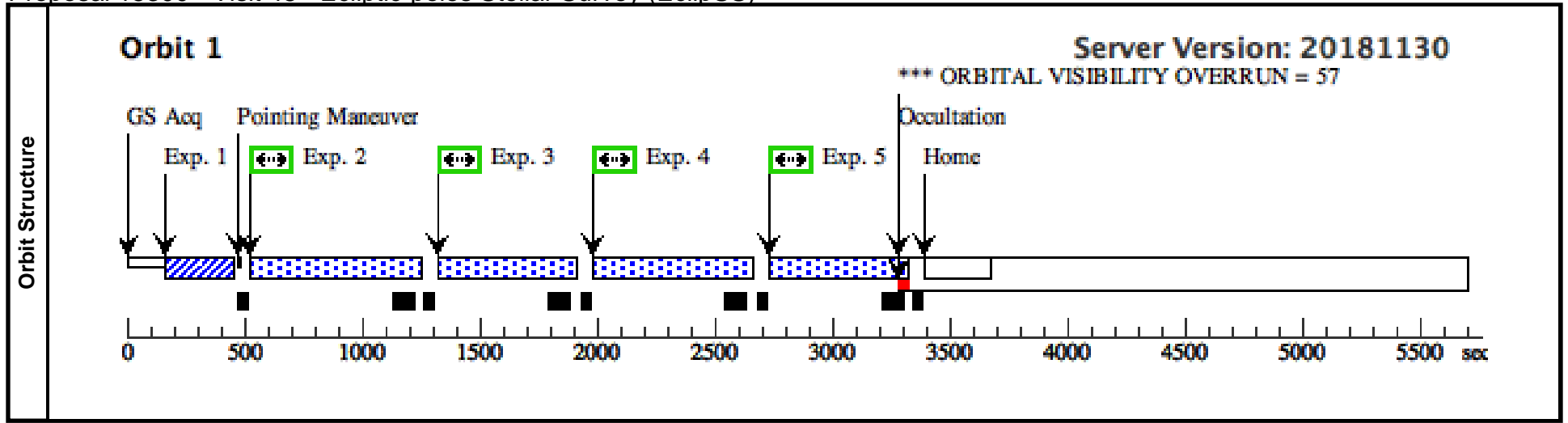

Proposal 15300 - Visit 49 - Ecliptic-poles Stellar Survey (EclipSS)

Thu Dec 13 22:02:09 GMT 2018

Visit	Proposal 15300, Visit 49, scheduling Diagnostic Status: Warning Scientific Instruments: COS/FUV, COS/NUV Special Requirements: (none)									
	(Visit 49) Warning (Form): For the best data quality, it is strongly recommended that the maximum number of allowed FP-POS positions is used when observing at a given COS CENWAVE setting. See full description for details. (Visit 49) Warning (Orbit Planner): ORBITAL VISIBILITY OVERRUN									
Diagnosics										
Fixed Targets	#	Name	Target Coordinates	Targ. Coord. Corrections	Fluxes	Miscellaneous				
	(49)	HD30501	RA: 04 45 38.5797 (71.4107487d) Dec: -50 04 27.22 (-50.07423d) Equinox: J2000	Proper Motion RA: -446.09 mas/yr Proper Motion Dec: -336.70 mas/yr Parallax: 0.04793" Epoch of Position: 2000 Radial Velocity: 0.0 km/sec	V=7.58+/-0.1 sptyp= K2V; (B-V)= 0.88 mag; dist= 21 pc	Reference Frame: ICRS				
Comments: Category=STAR Description=[K V-IV] Extended=NO										
Exposures	#	Label (ETC Run)	Target	Config,Mode,Aperture	Spectral Els.	Opt. Params.	Special Reqs.	Groups	Exp. Time (Total)/[Actual Dur.]	Orbit
	1	(COS.ta.100 4341)	(49) HD30501	COS/NUV, ACQ/IMAGE, BOA	MIRRORA				14 Secs (14 Secs) [==>]	[1]
2	(COS.sp.100 5139)	(49) HD30501	COS/FUV, TIME-TAG, PSA	G130M 1222 A	BUFFER-TIME=46 6; FP-POS=3			566 Secs (566 Secs) [==>]	[1]	
Comments: Note: ETC simulation (for G130M-1291, so as to include Ly-alpha) is for an "extreme" FUV spectrum, scaled to V=7.2 mag, and thus will over-predict count rates for most of the targets (see Observation Description).										
3	(COS.sp.100 5139)	(49) HD30501	COS/FUV, TIME-TAG, PSA	G130M 1222 A	BUFFER-TIME=46 6; FP-POS=4			566 Secs (566 Secs) [==>]	[1]	
Comments: Note: ETC simulation (for G130M-1291, so as to include Ly-alpha) is for an "extreme" FUV spectrum, scaled to V=7.2 mag, and thus will over-predict count rates for most of the targets (see Observation Description).										
4	(COS.sp.100 5139)	(49) HD30501	COS/FUV, TIME-TAG, PSA	G130M 1291 A	BUFFER-TIME=46 6; FP-POS=3			566 Secs (566 Secs) [==>]	[1]	
Comments: Note: ETC simulation (for G130M-1291, so as to include Ly-alpha) is for an "extreme" FUV spectrum, scaled to V=7.2 mag, and thus will over-predict count rates for most of the targets (see Observation Description).										
5	(COS.sp.100 5139)	(49) HD30501	COS/FUV, TIME-TAG, PSA	G130M 1291 A	BUFFER-TIME=46 6; FP-POS=4			566 Secs (566 Secs) [==>]	[1]	
Comments: Note: ETC simulation (for G130M-1291, so as to include Ly-alpha) is for an "extreme" FUV spectrum, scaled to V=7.2 mag, and thus will over-predict count rates for most of the targets (see Observation Description).										

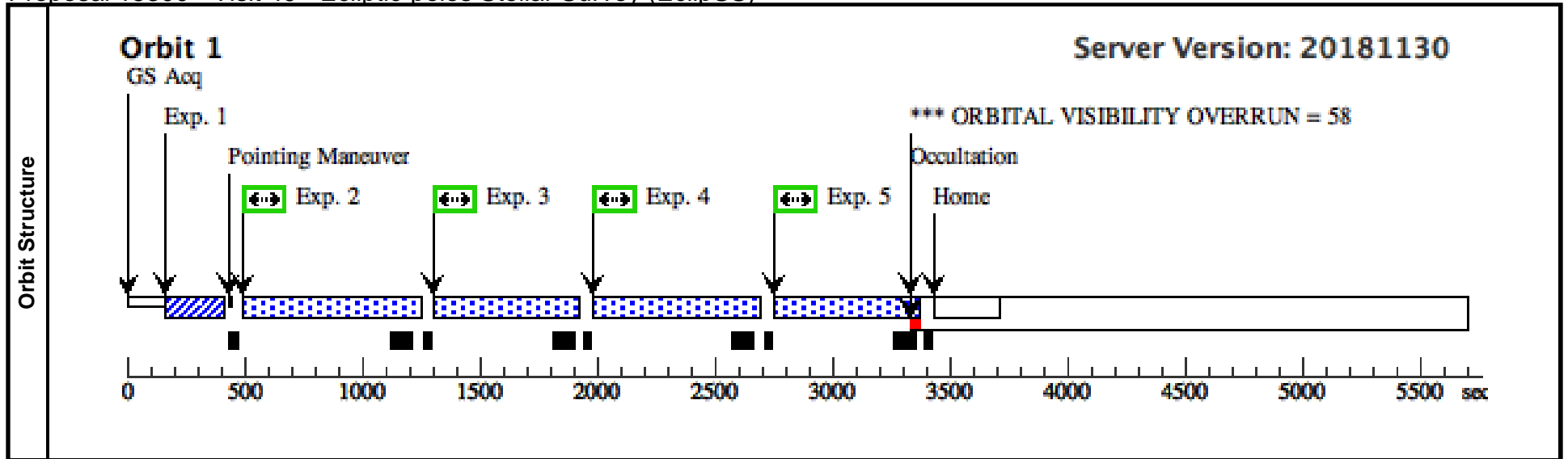

Proposal 15300 - Visit 53 - Ecliptic-poles Stellar Survey (EclipSS)

Thu Dec 13 22:02:09 GMT 2018

Visit	Proposal 15300, Visit 53 Diagnostic Status: Warning Scientific Instruments: COS/FUV, COS/NUV Special Requirements: (none) <i>Comments: Copy of failed visit 30</i>										
	(Visit 53) Warning (Form): For the best data quality, it is strongly recommended that the maximum number of allowed FP-POS positions is used when observing at a given COS CENWAVE setting. See full description for details. (Visit 53) Warning (Orbit Planner): ORBITAL VISIBILITY OVERRUN										
Diagnosics											
Fixed Targets	#	Name	Target Coordinates	Targ. Coord. Corrections		Fluxes	Miscellaneous				
	(30)	HD28471	RA: 04 25 9.1515 (66.2881313d) Dec: -64 04 48.25 (-64.08007d) Equinox: J2000	Proper Motion RA: -61.21 mas/yr Proper Motion Dec: 321.65 mas/yr Parallax: 0.2348" Epoch of Position: 2000 Radial Velocity: 0.0 km/sec	V=7.91+/-0.1 sptyp= G5V; (B-V)= 0.65 mag; dist= 44 pc		Reference Frame: ICRS				
<i>Comments: Category=STAR Description=[G V-IV] Extended=NO</i>											
Exposures	#	Label (ETC Run)	Target	Config,Mode,Aperture	Spectral Els.	Opt. Params.	Special Reqs.	Groups	Exp. Time (Total)/[Actual Dur.]		Orbit
	1	(COS.ta.100 4297)	(30) HD28471	COS/NUV, ACQ/IMAGE, BOA	MIRRORA					7 Secs (7 Secs) [==>]	[1]
2	(COS.sp.100 5139)	(30) HD28471	COS/FUV, TIME-TAG, PSA	G130M 1222 A	BUFFER-TIME=48 9; FP-POS=3				589 Secs (589 Secs) [==>]	[1]	
<i>Comments: Note: ETC simulation (for G130M-1291, so as to include Ly-alpha) is for an "extreme" FUV spectrum, scaled to V=7.2 mag, and thus will over-predict count rates for most of the targets (see Observation Description).</i>											
3	(COS.sp.100 5139)	(30) HD28471	COS/FUV, TIME-TAG, PSA	G130M 1222 A	BUFFER-TIME=48 9; FP-POS=4				589 Secs (589 Secs) [==>]	[1]	
<i>Comments: Note: ETC simulation (for G130M-1291, so as to include Ly-alpha) is for an "extreme" FUV spectrum, scaled to V=7.2 mag, and thus will over-predict count rates for most of the targets (see Observation Description).</i>											
4	(COS.sp.100 5139)	(30) HD28471	COS/FUV, TIME-TAG, PSA	G130M 1291 A	BUFFER-TIME=48 9; FP-POS=3				589 Secs (589 Secs) [==>]	[1]	
<i>Comments: Note: ETC simulation (for G130M-1291, so as to include Ly-alpha) is for an "extreme" FUV spectrum, scaled to V=7.2 mag, and thus will over-predict count rates for most of the targets (see Observation Description).</i>											
5	(COS.sp.100 5139)	(30) HD28471	COS/FUV, TIME-TAG, PSA	G130M 1291 A	BUFFER-TIME=48 9; FP-POS=4				589 Secs (589 Secs) [==>]	[1]	
<i>Comments: Note: ETC simulation (for G130M-1291, so as to include Ly-alpha) is for an "extreme" FUV spectrum, scaled to V=7.2 mag, and thus will over-predict count rates for most of the targets (see Observation Description).</i>											

