



15331 - Multi-Wavelength Spectroscopy of Tidal Disruption Flares: A Legacy

Sample for the LSST Era

Cycle: 25, Proposal Category: GO

(UV Initiative)

(Availability Mode: SUPPORTED)

INVESTIGATORS

<i>Name</i>	<i>Institution</i>	<i>E-Mail</i>
Dr. Stephen Bradley Cenko (PI) (Contact)	NASA Goddard Space Flight Center	brad.cenko@nasa.gov
Prof. Suvi Gezari (CoI)	University of Maryland	suvi@astro.umd.edu
Dr. Tzu-Yu Hung (CoI)	University of California - Santa Cruz	tiarahung@ucsc.edu
Dr. Nadejda Blagorodnova (CoI)	California Institute of Technology	nblago@caltech.edu
Prof. Shrinivas R. Kulkarni (CoI)	California Institute of Technology	srk@astro.caltech.edu
Dr. Lin Yan (CoI)	California Institute of Technology	lyan@caltech.edu
Mr. Nathaniel Roth (CoI)	University of Maryland	nathanielroth1@gmail.com
Prof. Sylvain Veilleux (CoI)	University of Maryland	veilleux@astro.umd.edu
Dr. Erin Amira Kara (CoI)	University of Maryland	ekara@astro.umd.edu
Dr. Sjoert van Velzen (CoI)	New York University	sjoert@nyu.edu

VISITS

<i>Visit</i>	<i>Targets used in Visit</i>	<i>Configurations used in Visit</i>	<i>Orbits Used</i>	<i>Last Orbit Planner Run</i>	<i>OP Current with Visit?</i>
01	(1) TDF1	STIS/CCD STIS/FUV-MAMA STIS/NUV-MAMA	2	25-Jan-2019 09:00:46.0	yes
02	(7) ZTF18ABGXJIE	STIS/CCD STIS/NUV-MAMA	2	25-Jan-2019 09:00:48.0	yes

Proposal 15331 (STScI Edit Number: 0, Created: Friday, January 25, 2019 at 9:01:45 AM Eastern Standard Time) - Overview

<i>Visit</i>	<i>Targets used in Visit</i>	<i>Configurations used in Visit</i>	<i>Orbits Used</i>	<i>Last Orbit Planner Run</i>	<i>OP Current with Visit?</i>
03	(7) ZTF18ABGXJIE	STIS/CCD STIS/FUV-MAMA	2	25-Jan-2019 09:00:49.0	yes
04	(1) TDF1	STIS/CCD STIS/FUV-MAMA	2	25-Jan-2019 09:00:50.0	yes
05	(1) TDF1	STIS/CCD STIS/NUV-MAMA	3	25-Jan-2019 09:00:52.0	yes
06	(1) TDF1	STIS/CCD STIS/FUV-MAMA	3	25-Jan-2019 09:00:54.0	yes
07	(8) ZTF18AAJUPNT	STIS/CCD STIS/FUV-MAMA STIS/NUV-MAMA	2	25-Jan-2019 09:00:56.0	yes
08	(8) ZTF18AAJUPNT	STIS/CCD STIS/NUV-MAMA	2	25-Jan-2019 09:00:58.0	yes
58	(8) ZTF18AAJUPNT	STIS/CCD STIS/NUV-MAMA	2	25-Jan-2019 09:00:59.0	yes
09	(8) ZTF18AAJUPNT	STIS/CCD STIS/FUV-MAMA	2	25-Jan-2019 09:01:00.0	yes
10	(8) ZTF18AAJUPNT	STIS/CCD STIS/NUV-MAMA	2	25-Jan-2019 09:01:02.0	yes
11	(8) ZTF18AAJUPNT	STIS/CCD STIS/FUV-MAMA	3	25-Jan-2019 09:01:03.0	yes
12	(2) TDF2	STIS/CCD STIS/FUV-MAMA	3	25-Jan-2019 09:01:05.0	yes
13	(3) TDF3	STIS/CCD STIS/FUV-MAMA STIS/NUV-MAMA	2	25-Jan-2019 09:01:06.0	yes

Proposal 15331 (STScI Edit Number: 0, Created: Friday, January 25, 2019 at 9:01:45 AM Eastern Standard Time) - Overview

<i>Visit</i>	<i>Targets used in Visit</i>	<i>Configurations used in Visit</i>	<i>Orbits Used</i>	<i>Last Orbit Planner Run</i>	<i>OP Current with Visit?</i>
14	(3) TDF3	STIS/CCD STIS/FUV-MAMA STIS/NUV-MAMA	2	25-Jan-2019 09:01:08.0	yes
15	(3) TDF3	STIS/CCD STIS/NUV-MAMA	2	25-Jan-2019 09:01:09.0	yes
16	(3) TDF3	STIS/CCD STIS/FUV-MAMA	2	25-Jan-2019 09:01:10.0	yes
17	(6) AT2018ZR	STIS/CCD STIS/NUV-MAMA	3	25-Jan-2019 09:01:12.0	yes
18	(6) AT2018ZR	STIS/CCD STIS/FUV-MAMA	3	25-Jan-2019 09:01:14.0	yes
19	(4) TDF4	STIS/CCD STIS/FUV-MAMA STIS/NUV-MAMA	2	25-Jan-2019 09:01:16.0	yes
20	(4) TDF4	STIS/CCD STIS/FUV-MAMA STIS/NUV-MAMA	2	25-Jan-2019 09:01:17.0	yes
21	(4) TDF4	STIS/CCD STIS/NUV-MAMA	2	25-Jan-2019 09:01:18.0	yes
22	(4) TDF4	STIS/CCD STIS/FUV-MAMA	2	25-Jan-2019 09:01:19.0	yes
23	(4) TDF4	STIS/CCD STIS/NUV-MAMA	3	25-Jan-2019 09:01:21.0	yes
24	(4) TDF4	STIS/CCD STIS/FUV-MAMA	3	25-Jan-2019 09:01:22.0	yes
25	(5) TDF5	STIS/CCD STIS/FUV-MAMA STIS/NUV-MAMA	2	25-Jan-2019 09:01:24.0	yes

Proposal 15331 (STScI Edit Number: 0, Created: Friday, January 25, 2019 at 9:01:45 AM Eastern Standard Time) - Overview

<i>Visit</i>	<i>Targets used in Visit</i>	<i>Configurations used in Visit</i>	<i>Orbits Used</i>	<i>Last Orbit Planner Run</i>	<i>OP Current with Visit?</i>
26	(5) TDF5	STIS/CCD STIS/FUV-MAMA STIS/NUV-MAMA	2	25-Jan-2019 09:01:25.0	yes
27	(5) TDF5	STIS/CCD STIS/NUV-MAMA	2	25-Jan-2019 09:01:26.0	yes
28	(5) TDF5	STIS/CCD STIS/FUV-MAMA	2	25-Jan-2019 09:01:28.0	yes
29	(5) TDF5	STIS/CCD STIS/NUV-MAMA	3	25-Jan-2019 09:01:30.0	yes
30	(5) TDF5	STIS/CCD STIS/FUV-MAMA	3	25-Jan-2019 09:01:31.0	yes
31	(6) AT2018ZR	STIS/CCD STIS/FUV-MAMA STIS/NUV-MAMA	3	25-Jan-2019 09:01:33.0	yes
36	(9) ZTF18AAHQKBT	STIS/CCD STIS/NUV-MAMA	3	25-Jan-2019 09:01:35.0	yes
37	(9) ZTF18AAHQKBT	STIS/CCD STIS/FUV-MAMA	3	25-Jan-2019 09:01:37.0	yes
32	(6) AT2018ZR	STIS/CCD STIS/FUV-MAMA STIS/NUV-MAMA	3	25-Jan-2019 09:01:38.0	yes
33	(6) AT2018ZR	STIS/CCD STIS/FUV-MAMA STIS/NUV-MAMA	3	25-Jan-2019 09:01:40.0	yes
34	(6) AT2018ZR	STIS/CCD STIS/FUV-MAMA STIS/NUV-MAMA	3	25-Jan-2019 09:01:43.0	yes

<i>Visit</i>	<i>Targets used in Visit</i>	<i>Configurations used in Visit</i>	<i>Orbits Used</i>	<i>Last Orbit Planner Run</i>	<i>OP Current with Visit?</i>
35	(6) AT2018ZR	STIS/CCD STIS/FUV-MAMA STIS/NUV-MAMA	3	25-Jan-2019 09:01:44.0	yes

93 Total Orbits Used

ABSTRACT

When a star passes within the sphere of disruption of a massive black hole, tidal forces will overcome self-gravity and unbind the star. While approximately half of the stellar debris is ejected at high velocities, the remaining material stays bound to the black hole and accretes, resulting in a luminous, long-lived transient known as a tidal disruption flare (TDF). In addition to serving as unique laboratories for accretion physics, TDFs offer the hope of measuring black hole masses in galaxies much too distant for resolved kinematic studies.

In order to realize this potential, we must better understand the detailed processes by which the bound debris circularizes and forms an accretion disk. Spectroscopy is critical to this effort, as emission and absorption line diagnostics provide insight into the location and physical state (velocity, density, composition) of the emitting gas (in analogy with quasars). UV spectra are particularly critical, as most strong atomic features fall in this bandpass, and high-redshift TDF discoveries from LSST will sample rest-frame UV wavelengths.

Here we propose to obtain a sequence of UV (HST) and optical (Gemini/GMOS) spectra for a sample of 5 TDFs discovered by the Zwicky Transient Facility, doubling the number of TDFs with UV spectra. Our observations will directly test models for the generation of the UV/optical emission (circularization vs reprocessing) by searching for outflows and measuring densities, temperatures, and composition as a function of time. This effort is critical to developing the framework by which we can infer black hole properties (e.g., mass) from LSST TDF discoveries.

OBSERVING DESCRIPTION

We request ToO HST observations of five nearby ($z < \sim 0.3$) TDFs in Cycle 25 in the bandpass from 1200-3000 Å. HST, with its sensitive UV spectrographs and exquisite angular resolution, is the only facility that can conduct such observations (even ASASSN-14li, the brightest UV/optical TDF to date, was much too faint for the Swift UV grism). As our primary objective is dedicated to UV science, we consider this proposal appropriate for the UV initiative. We note that, because of the slow evolution of these sources, a non-disruptive ToO is still sufficient to sample the super-Eddington phase around peak.

In order to avoid triggering on false positives (i.e., supernovae, AGN outbursts), we require the following (strict) criteria be met in order to trigger our program:

- Detection of an optical transient astrometrically consistent with a galaxy nucleus.
- Evidence of an absence of previous AGN activity, either photometrically (i.e., through a constant light curve in historical databases) and/or spectroscopically (i.e., a spectrum that is inconsistent with an AGN or LINER).
- Spectroscopic and/or photometric properties distinct from supernovae (e.g., slow temporal evolution, spectra resembling previous TDFs).
- $z < \sim 0.3$ (so that we are sampling rest-frame UV emission with our spectra).
- Swift UV detection (limited host extinction, and also for instrument safety checks).

We anticipate that most (if not all) of our triggers will come from the Zwicky Transient Facility (ZTF), of which the PI and most co-I's are team members. ZTF will employ the same 1.2 m Schmidt telescope at Palomar Observatory as the highly successful Palomar Transient Factory (PTF) project, but with a new 47 deg^2 camera (compared to the previous 7.1 deg^2 camera for PTF). By surveying the entire visible sky every 3-4 nights in g- and r-band, ZTF is expected to discover TDFs at a rate of $\sim 10 \text{ yr}^{-1}$. With commissioning expected to start in November 2017, ZTF will for the first time provide a sizable sample of uniformly selected TDFs for detailed study. As such, we estimate a very high likelihood of finding at least one suitable trigger in Cycle 25 ($> 95\%$).

While the exact details of our source cannot be known at the moment, we can use PS1-10jh and previous PTF discoveries as templates to plan our observation. We assume an r-band magnitude around peak of ~ 20 (\sim the ZTF single-epoch limit), a blackbody spectrum with $T \sim 3e4 \text{ K}$, and little to no host extinction (the requirement of a Swift UV detection will limit us to at most lightly extinguished sight lines).

Inputting this SED into the online exposure time calculator, we find we can achieve the largest SNR in the near-UV using STIS with the NUV-MAMA detector and the G230L (1570-3180 Å) grating. We assume our targets are visible for 54 minutes each orbit. After including overheads for guide-star acquisition (6 min for the first orbit, 4 min for the subsequent orbits), target acquisition (~ 8 min for an extended source, no peak-up required for 0.2" slit width), and wavelength calibration (4 min per orbit), we find that we can obtain 36 min of exposure in the first orbit (44 in subsequent orbits). According to the exposure time calculator, we would expect a SNR per resolution element ≥ 5 for the range from 1650-3100 Å for the

continuum emission for a single orbit. This should allow us to easily detect strong narrow absorption lines, as well as emission lines as we have observed from, e.g., ASASSN-14li and iPTF15af.

In the far UV, we have compared the throughput possible with both COS (G140L grating) and STIS (G140L grating) and find that they are roughly comparable. To enable isolation of the transient emission from the underlying host (via the greater spatial resolution), we have chosen STIS with the FUV-MAMA detector (however, if the host is particularly faint in the UV, we may consider COS for its higher spectral resolution).

Using similar overheads as above, with a single orbit we find a SNR \geq over the range from 1200-1700 Å for the continuum. Here we should be most sensitive to C IV , Si IV , and, most importantly, Ly- α (both in emission and absorption). Thus, for the initial spectrum (around maximum light) we request 2 orbits of observations.

At $dt = 1$ month, PS1-10jh was only ~ 0.3 mag fainter than at peak brightness. Thus for our second epoch we will repeat the same sequence as at peak (1 NUV and 1 FUV).

At a time of $dt \sim 3$ months, PS1-10jh was ~ 1 mag fainter than at peak. Repeating the above calculations for a source with $r \sim 21$ mag, we find that we can achieve a comparable SNR (≥ 5) for the NUV and FUV portions of the spectrum with 2 orbits for each configuration. Again, this will be sufficient for the detection of emission lines, and should still enable constraints on the presence of strong absorption features as well. Thus, for the second epoch we request 4 additional orbits.

Finally, at a time of $dt = 9$ months, PS1-10jh was ~ 2 mag fainter than at peak. In 3 orbits in both the NUV and FUV setups, we find that we can reach SNR ≥ 3 from 1700-3000 Å in the NUV and 1200-1650 Å in the FUV. Thus, for the third epoch we request 6 additional orbits. Given the late stage past peak, these can easily be split up into multiple visits (as required for MAMA scheduling).

Of course the actual observing sequence will be modified according to the characteristics of each source. In total we request 70 orbits of STIS spectroscopy to obtain a sequence of UV spectra on five newly discovered TDFs.

Proposal 15331 - Visit 01 - Multi-Wavelength Spectroscopy of Tidal Disruption Flares: A Legacy Sample for the LSST Era

Fri Jan 25 14:01:45 GMT 2019

Visit	Proposal 15331, Visit 01, withdrawn Diagnostic Status: Warning Scientific Instruments: STIS/NUV-MAMA, STIS/CCD, STIS/FUV-MAMA Special Requirements: ON HOLD ; TOO RESPONSE TIME 21.0D <i>On Hold Comments: Awaiting ToO trigger</i>										
	(Visit 01) Warning (Orbit Planner): ORBITAL VISIBILITY OVERRUN (Visit 01) Warning (Orbit Planner): ORBITAL VISIBILITY OVERRUN										
Diagnosics											
Patterns	#	Primary Pattern				Secondary Pattern				Exposures	
	(1)	Pattern Type=STIS-ALONG-SLIT		Coordinate Frame=POS-TARG						(2), (3)	
		Purpose=DITHER		Pattern Orientation=90.0							
		Number Of Points=3		Angle Between Sides=							
		Point Spacing=0.4165		Center Pattern=false							
		Line Spacing=									
Generic Targets	#	Name		Criteria		Description					
	(1)	TDF1		Tidal Disruption Flare		ACCRETION DISK NUCLEUS					
<i>Comments: Nuclear transient not obviously AGN or supernova at z <~ 0.3.</i>											
Exposures	#	Label (ETC Run)	Target	Config,Mode,Aperture	Spectral Els.	Opt. Params.	Special Reqs.	Groups	Exp. Time (Total)/[Actual Dur.]		Orbit
	1	(STIS.ta.100 3498)	(1) TDF1	STIS/CCD, ACQ, F28X50LP	MIRROR				45 Secs (45 Secs)		
										[==>]	[1]
	2	(STIS.sp.10 03499)	(1) TDF1	STIS/NUV-MAMA, ACCUM, 52X0.2	G230L 2376 A			Pattern 1, Exps 2-2 in Visit 01 (1)	674 Secs (2022 Secs)		
										[==>(Pattern 1)]	[1]
									[==>(Pattern 2)]		
									[==>(Pattern 3)]		
3	(STIS.sp.10 03500)	(1) TDF1	STIS/FUV-MAMA, ACCUM, 52X0.2	G140L 1425 A			Pattern 1, Exps 3-3 in Visit 01 (1)	920 Secs (2760 Secs)			
									[==>(Pattern 1)]		
									[==>(Pattern 2)]	[2]	
									[==>(Pattern 3)]		

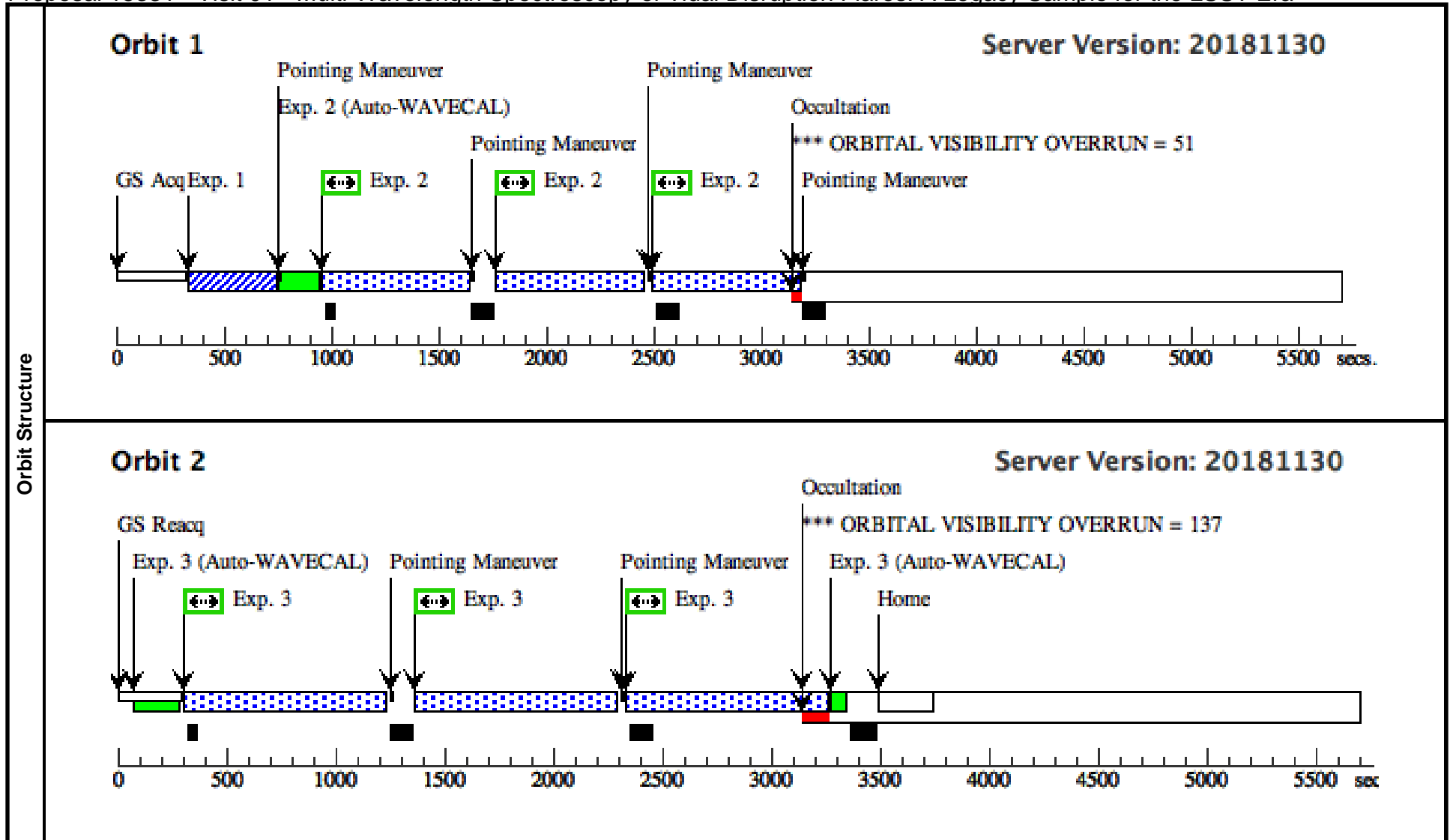

Proposal 15331 - Visit 02 - Multi-Wavelength Spectroscopy of Tidal Disruption Flares: A Legacy Sample for the LSST Era

Fri Jan 25 14:01:46 GMT 2019

Visit	Proposal 15331, Visit 02, completed Diagnostic Status: Warning Scientific Instruments: STIS/NUV-MAMA, STIS/CCD Special Requirements: BETWEEN 20-AUG-2018:00:00:00 AND 31-AUG-2018:00:00:00										
	(Visit 02) Warning (Orbit Planner): ORBITAL VISIBILITY OVERRUN (Visit 02) Warning (Orbit Planner): ORBITAL VISIBILITY OVERRUN										
Diagnosics											
Patterns	#	Primary Pattern				Secondary Pattern				Exposures	
	(1)	Pattern Type=STIS-ALONG-SLIT		Coordinate Frame=POS-TARG						(2), (3)	
		Purpose=DITHER		Pattern Orientation=90.0							
		Number Of Points=3		Angle Between Sides=							
		Point Spacing=0.4165		Center Pattern=false							
		Line Spacing=									
Fixed Targets	#	Name	Target Coordinates		Targ. Coord. Corrections		Fluxes		Miscellaneous		
	(7)	ZTF18ABGXJIE	RA: 19 00 2.0506 (285.0085442d) Dec: +51 55 23.15 (51.92310d) Equinox: J2000				V=19.0+/-0.1		Reference Frame: ICRS		
Comments: Category=GALAXY Description=[ACCRETION DISK, NUCLEUS] Extended=NO											
Exposures	#	Label (ETC Run)	Target	Config,Mode,Aperture	Spectral Els.	Opt. Params.	Special Reqs.	Groups	Exp. Time (Total)/[Actual Dur.]		Orbit
	1	(STIS.ta.118 3929)	(7) ZTF18ABGXJIE	STIS/CCD, ACQ, F28X50LP	MIRROR				60 Secs (60 Secs)		
										[==>]	[1]
	2	(STIS.sp.11 83931)	(7) ZTF18ABGXJIE	STIS/NUV-MAMA, ACCUM, 52X0.2	G230L 2376 A				Pattern 1, Exps 2-2 in Visit 02 (1)	720. Secs (2160 Secs)	
									[==>(Pattern 1)]	[1]	
									[==>(Pattern 2)]		
									[==>(Pattern 3)]		
3	(STIS.sp.11 83931)	(7) ZTF18ABGXJIE	STIS/NUV-MAMA, ACCUM, 52X0.2	G230L 2376 A				Pattern 1, Exps 3-3 in Visit 02 (1)	950. Secs (2850 Secs)		
									[==>(Pattern 1)]	[2]	
									[==>(Pattern 2)]		
									[==>(Pattern 3)]		

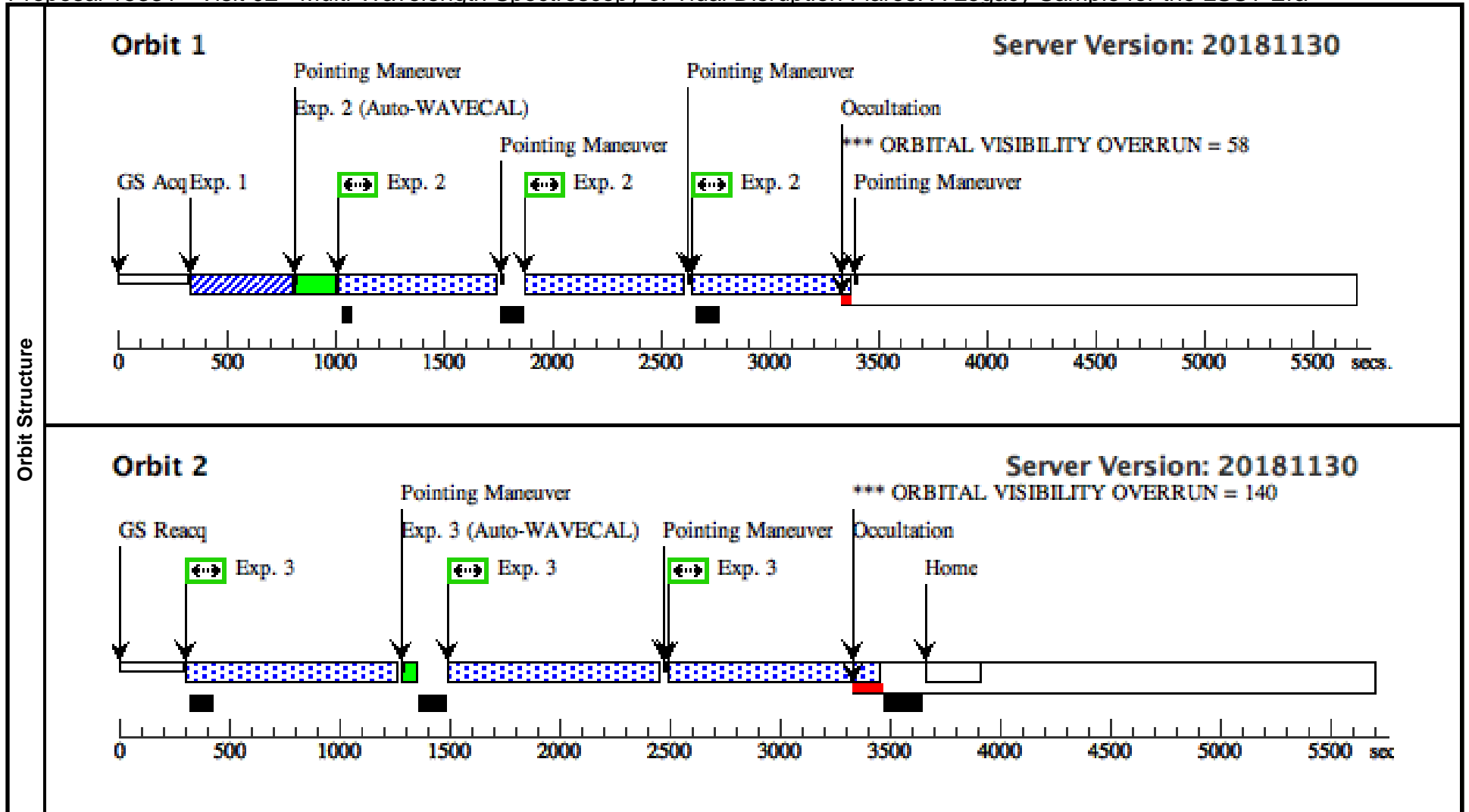

Proposal 15331 - Visit 03 - Multi-Wavelength Spectroscopy of Tidal Disruption Flares: A Legacy Sample for the LSST Era

Fri Jan 25 14:01:46 GMT 2019

Visit	Proposal 15331, Visit 03, completed Diagnostic Status: Warning Scientific Instruments: STIS/CCD, STIS/FUV-MAMA Special Requirements: BETWEEN 20-AUG-2018:00:00:00 AND 31-AUG-2018:00:00:00										
	(Visit 03) Warning (Orbit Planner): ORBITAL VISIBILITY OVERRUN (Visit 03) Warning (Orbit Planner): ORBITAL VISIBILITY OVERRUN										
Diagnosics											
Patterns	#	Primary Pattern				Secondary Pattern				Exposures	
	(1)	Pattern Type=STIS-ALONG-SLIT		Coordinate Frame=POS-TARG						(2), (3)	
		Purpose=DITHER		Pattern Orientation=90.0							
		Number Of Points=3		Angle Between Sides=							
		Point Spacing=0.4165		Center Pattern=false							
		Line Spacing=									
Fixed Targets	#	Name	Target Coordinates		Targ. Coord. Corrections		Fluxes		Miscellaneous		
	(7)	ZTF18ABGXJIE	RA: 19 00 2.0506 (285.0085442d) Dec: +51 55 23.15 (51.92310d) Equinox: J2000				V=19.0+/-0.1		Reference Frame: ICRS		
Comments: Category=GALAXY Description=[ACCRETION DISK, NUCLEUS] Extended=NO											
Exposures	#	Label (ETC Run)	Target	Config,Mode,Aperture	Spectral Els.	Opt. Params.	Special Reqs.	Groups	Exp. Time (Total)/[Actual Dur.]		Orbit
	1	(STIS.ta.118 3929)	(7) ZTF18ABGXJIE	STIS/CCD, ACQ, F28X50LP	MIRROR				60 Secs (60 Secs)		
									[==>]		[1]
	2	(STIS.sp.11 83932)	(7) ZTF18ABGXJIE	STIS/FUV-MAMA, ACCUM, 52X0.2	G140L 1425 A			Pattern 1, Exps 2-2 in Visit 03 (1)	720. Secs (2160 Secs)		
								[==>(Pattern 1)]			
								[==>(Pattern 2)]		[1]	
								[==>(Pattern 3)]			
3	(STIS.sp.11 83932)	(7) ZTF18ABGXJIE	STIS/FUV-MAMA, ACCUM, 52X0.2	G140L 1425 A			Pattern 1, Exps 3-3 in Visit 03 (1)	950. Secs (2850 Secs)			
								[==>(Pattern 1)]			
								[==>(Pattern 2)]		[2]	
								[==>(Pattern 3)]			

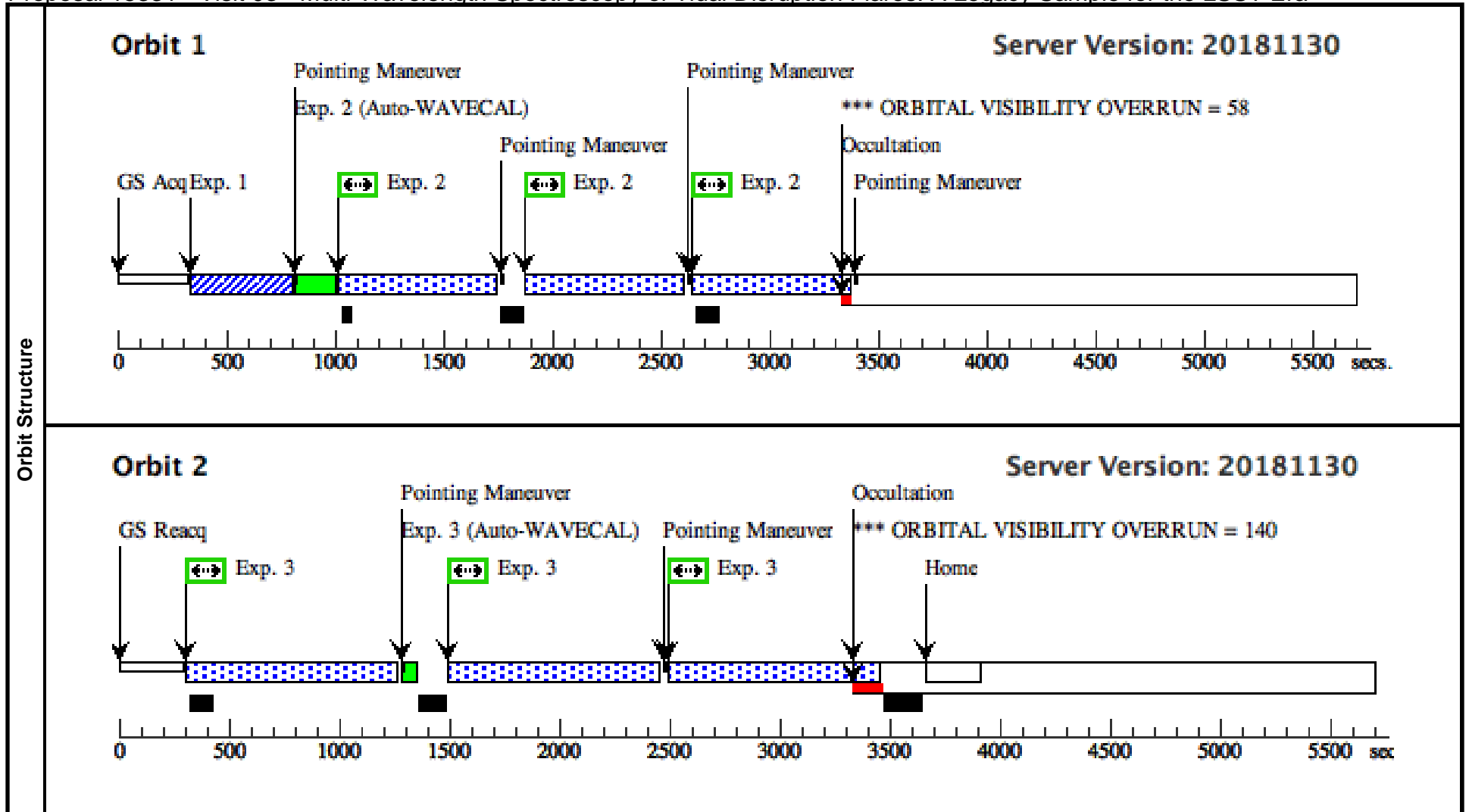

Proposal 15331 - Visit 04 - Multi-Wavelength Spectroscopy of Tidal Disruption Flares: A Legacy Sample for the LSST Era

Fri Jan 25 14:01:46 GMT 2019

Visit	Proposal 15331, Visit 04, withdrawn Diagnostic Status: Warning Scientific Instruments: STIS/CCD, STIS/FUV-MAMA Special Requirements: AFTER 01 BY 75 D TO 105 D; ON HOLD <i>On Hold Comments: Awaiting ToO Trigger.</i>										
	(Visit 04) Warning (Orbit Planner): ORBITAL VISIBILITY OVERRUN (Visit 04) Warning (Orbit Planner): ORBITAL VISIBILITY OVERRUN										
Diagnosics											
Patterns	#	Primary Pattern				Secondary Pattern				Exposures	
	(1)	Pattern Type=STIS-ALONG-SLIT		Coordinate Frame=POS-TARG						(2), (3)	
		Purpose=DITHER		Pattern Orientation=90.0							
		Number Of Points=3		Angle Between Sides=							
		Point Spacing=0.4165		Center Pattern=false							
		Line Spacing=									
Generic Targets	#	Name		Criteria		Description					
	(1)	TDF1		Tidal Disruption Flare		ACCRETION DISK NUCLEUS					
<i>Comments: Nuclear transient not obviously AGN or supernova at z <- 0.3.</i>											
Exposures	#	Label (ETC Run)	Target	Config,Mode,Aperture	Spectral Els.	Opt. Params.	Special Reqs.	Groups	Exp. Time (Total)/[Actual Dur.]		Orbit
	1	(STIS.ta.100 3503)	(1) TDF1	STIS/CCD, ACQ, F28X50LP	MIRROR				100 Secs (100 Secs)		
										[==>]	[1]
	2	(STIS.sp.10 03505)	(1) TDF1	STIS/FUV-MAMA, ACCUM, 52X0.2	G140L 1425 A			Pattern 1, Exps 2-2 in Visit 04 (1)	600. Secs (1800 Secs)		
										[==>(Pattern 1)]	[1]
									[==>(Pattern 2)]		
									[==>(Pattern 3)]		
3	(STIS.sp.10 03505)	(1) TDF1	STIS/FUV-MAMA, ACCUM, 52X0.2	G140L 1425 A			Pattern 1, Exps 3-3 in Visit 04 (1)	885. Secs (2655 Secs)			
									[==>(Pattern 1)]		
									[==>(Pattern 2)]	[2]	
									[==>(Pattern 3)]		

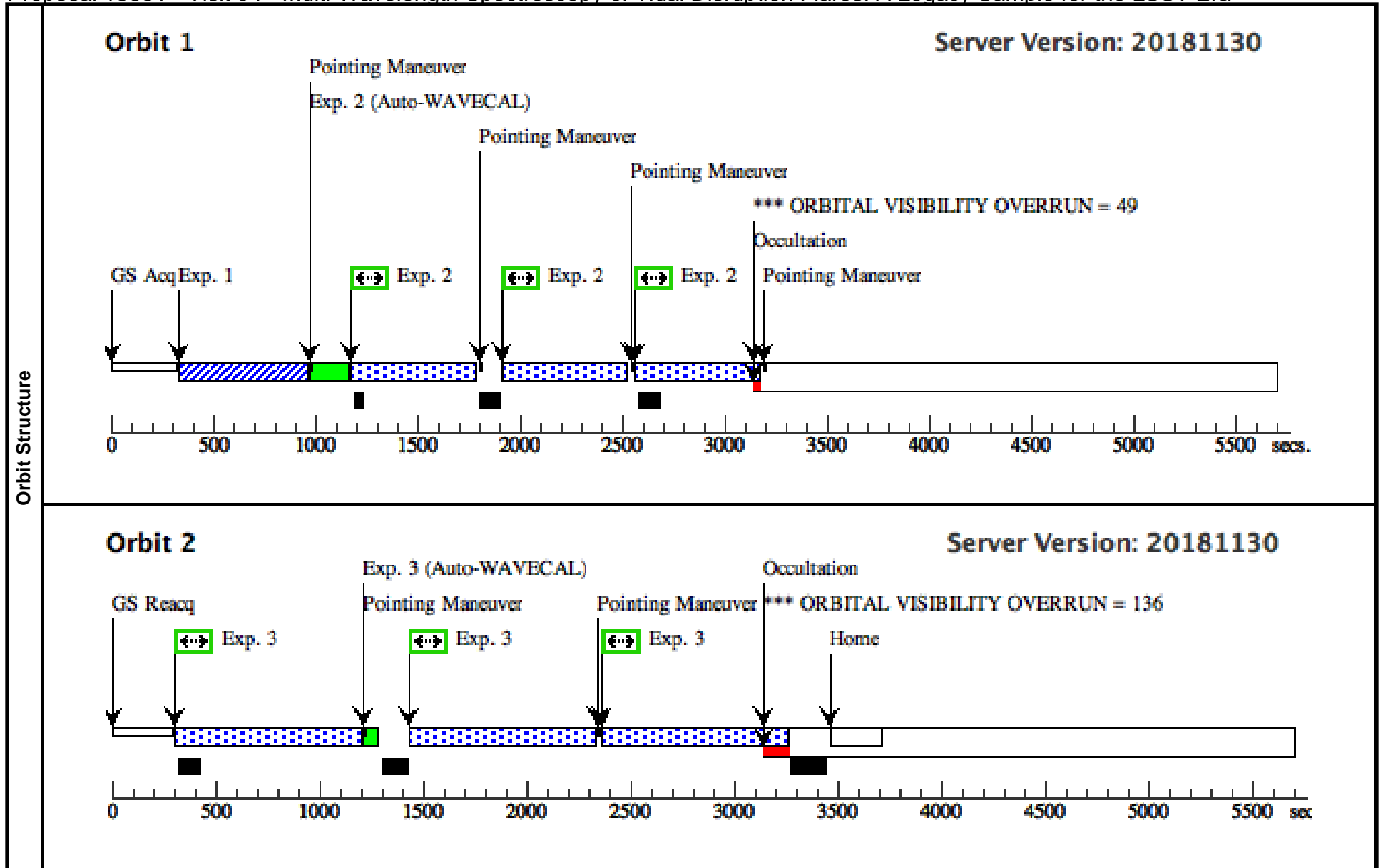

Proposal 15331 - Visit 05 - Multi-Wavelength Spectroscopy of Tidal Disruption Flares: A Legacy Sample for the LSST Era

Fri Jan 25 14:01:46 GMT 2019

Visit	Proposal 15331, Visit 05, withdrawn Diagnostic Status: Warning Scientific Instruments: STIS/NUV-MAMA, STIS/CCD Special Requirements: AFTER 01 BY 150 D TO 210 D; ON HOLD <i>On Hold Comments: Awaiting ToO Trigger.</i>										
Diagnostics	(Visit 05) Warning (Orbit Planner): ORBITAL VISIBILITY OVERRUN (Visit 05) Warning (Orbit Planner): ORBITAL VISIBILITY OVERRUN (Visit 05) Warning (Orbit Planner): ORBITAL VISIBILITY OVERRUN										
Patterns	#	Primary Pattern				Secondary Pattern				Exposures	
	(1)	Pattern Type=STIS-ALONG-SLIT Purpose=DITHER Number Of Points=3 Point Spacing=0.4165 Line Spacing=		Coordinate Frame=POS-TARG Pattern Orientation=90.0 Angle Between Sides= Center Pattern=false						(2), (3), (4)	
Generic Targets	#	Name	Criteria			Description					
	(1)	TDF1	Tidal Disruption Flare			ACCRETION DISK NUCLEUS <i>Comments: Nuclear transient not obviously AGN or supernova at z <- 0.3.</i>					
Exposures	#	Label (ETC Run)	Target	Config,Mode,Aperture	Spectral Els.	Opt. Params.	Special Reqs.	Groups	Exp. Time (Total)/[Actual Dur.]		Orbit
	1	(STIS.ta.100 3507)	(1) TDF1	STIS/CCD, ACQ, 50CCD	MIRROR				60 Secs (60 Secs)		
									[==>]		[1]
	2	(STIS.sp.10 03509)	(1) TDF1	STIS/NUV-MAMA, ACCUM, 52X0.2	G230L 2376 A			Pattern 1, Exps 2-2 in Visit 05 (1)	650. Secs (1950 Secs)		
									[==>(Pattern 1)] [==>(Pattern 2)] [==>(Pattern 3)]		[1]
3	(STIS.sp.10 03509)	(1) TDF1	STIS/NUV-MAMA, ACCUM, 52X0.2	G230L 2376 A			Pattern 1, Exps 3-3 in Visit 05 (1)	885. Secs (2655 Secs)			
								[==>(Pattern 1)] [==>(Pattern 2)] [==>(Pattern 3)]		[2]	
4	(STIS.sp.10 03509)	(1) TDF1	STIS/NUV-MAMA, ACCUM, 52X0.2	G230L 2376 A			Pattern 1, Exps 4-4 in Visit 05 (1)	885. Secs (2655 Secs)			
								[==>(Pattern 1)] [==>(Pattern 2)] [==>(Pattern 3)]		[3]	

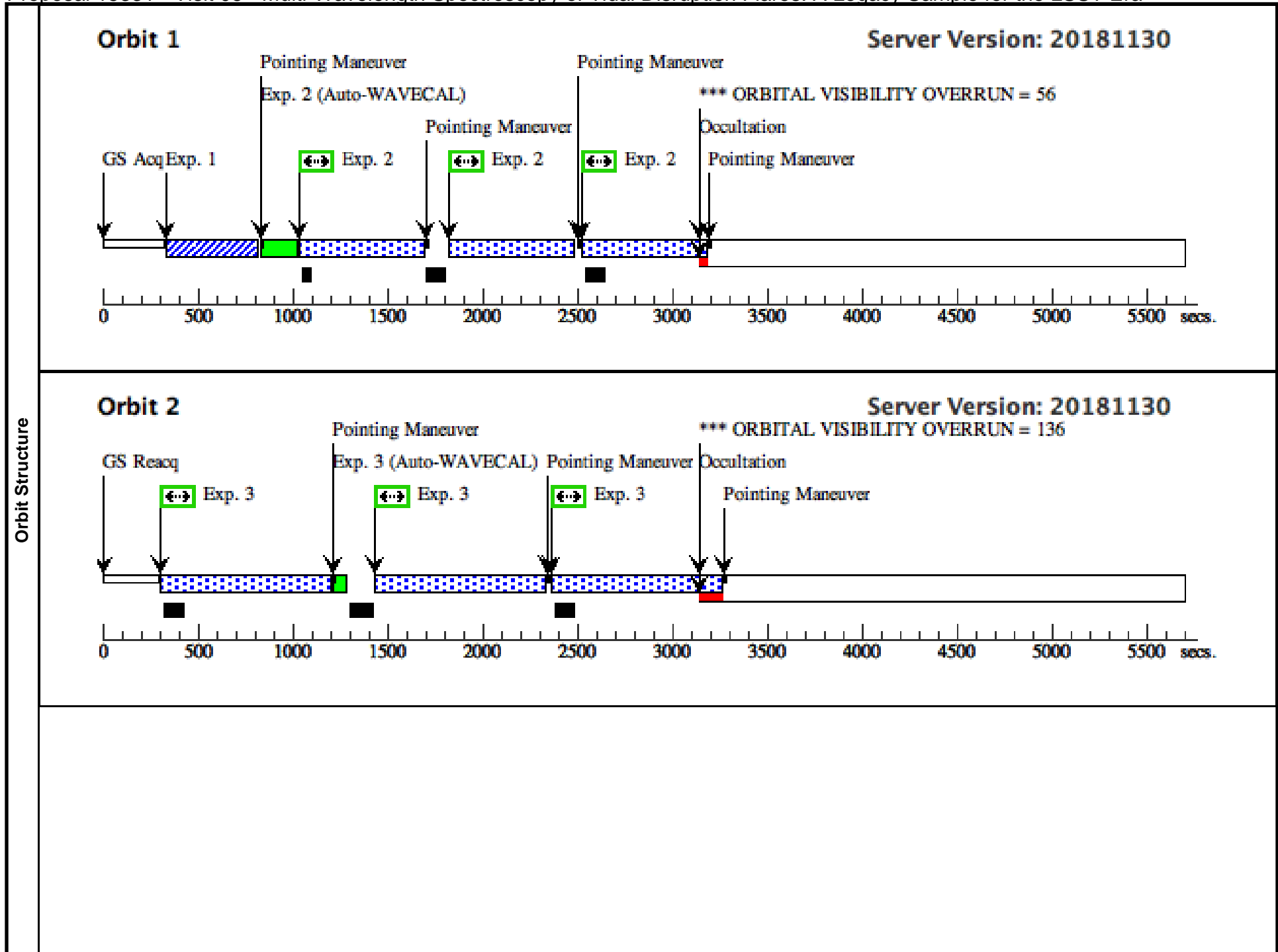

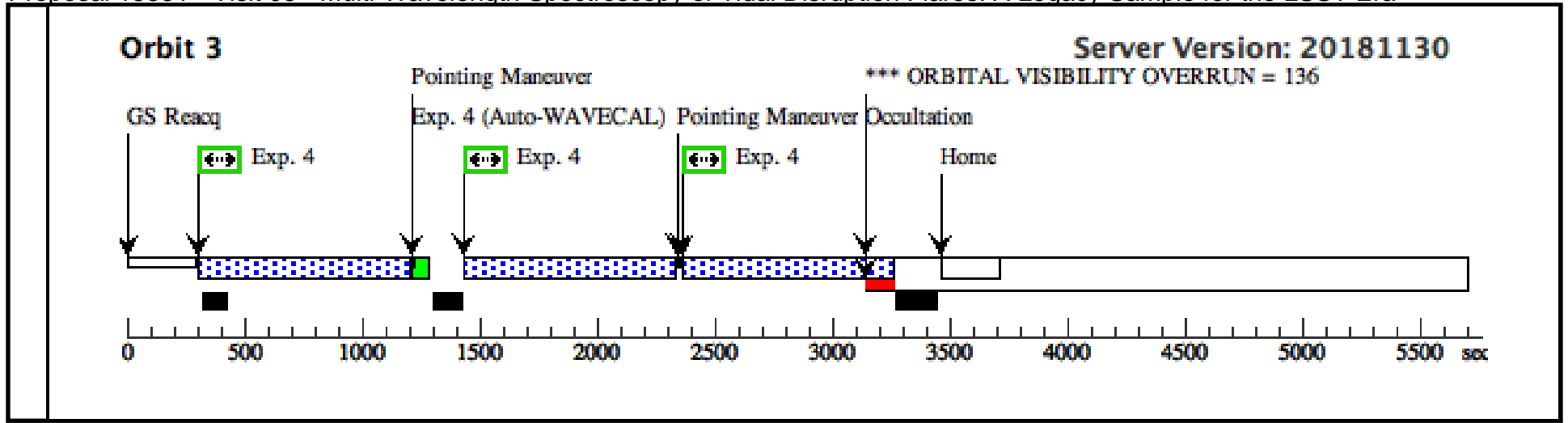

Proposal 15331 - Visit 06 - Multi-Wavelength Spectroscopy of Tidal Disruption Flares: A Legacy Sample for the LSST Era

Fri Jan 25 14:01:46 GMT 2019

Visit	Proposal 15331, Visit 06, withdrawn Diagnostic Status: Warning Scientific Instruments: STIS/CCD, STIS/FUV-MAMA Special Requirements: AFTER 01 BY 150 D TO 210 D; ON HOLD <i>On Hold Comments: Awaiting ToO Trigger.</i>										
	(Visit 06) Warning (Orbit Planner): ORBITAL VISIBILITY OVERRUN (Visit 06) Warning (Orbit Planner): ORBITAL VISIBILITY OVERRUN (Visit 06) Warning (Orbit Planner): ORBITAL VISIBILITY OVERRUN										
Diagnosics											
Patterns	#	Primary Pattern				Secondary Pattern				Exposures	
	(1)	Pattern Type=STIS-ALONG-SLIT		Coordinate Frame=POS-TARG						(2), (3), (4)	
		Purpose=DITHER		Pattern Orientation=90.0							
		Number Of Points=3		Angle Between Sides=							
		Point Spacing=0.4165		Center Pattern=false							
		Line Spacing=									
Generic Targets	#	Name	Criteria			Description					
	(1)	TDF1	Tidal Disruption Flare			ACCRETION DISK NUCLEUS					
<i>Comments: Nuclear transient not obviously AGN or supernova at z <- 0.3.</i>											
Exposures	#	Label (ETC Run)	Target	Config,Mode,Aperture	Spectral Els.	Opt. Params.	Special Reqs.	Groups	Exp. Time (Total)/[Actual Dur.]		Orbit
	1	(STIS.ta.100 3507)	(1) TDF1	STIS/CCD, ACQ, 50CCD	MIRROR				60 Secs (60 Secs)		
										[==>]	[1]
	2	(STIS.sp.10 03510)	(1) TDF1	STIS/FUV-MAMA, ACCUM, 52X0.2	G140L 1425 A			Pattern 1, Exps 2-2 in Visit 06 (1)	650. Secs (1950 Secs)		
										[==>(Pattern 1)]	[1]
									[==>(Pattern 2)]		
									[==>(Pattern 3)]		
3	(STIS.sp.10 03510)	(1) TDF1	STIS/FUV-MAMA, ACCUM, 52X0.2	G140L 1425 A			Pattern 1, Exps 3-3 in Visit 06 (1)	885. Secs (2655 Secs)			
									[==>(Pattern 1)]	[2]	
									[==>(Pattern 2)]		
									[==>(Pattern 3)]		
4	(STIS.sp.10 03510)	(1) TDF1	STIS/FUV-MAMA, ACCUM, 52X0.2	G140L 1425 A			Pattern 1, Exps 4-4 in Visit 06 (1)	885. Secs (2655 Secs)			
									[==>(Pattern 1)]	[3]	
									[==>(Pattern 2)]		
									[==>(Pattern 3)]		

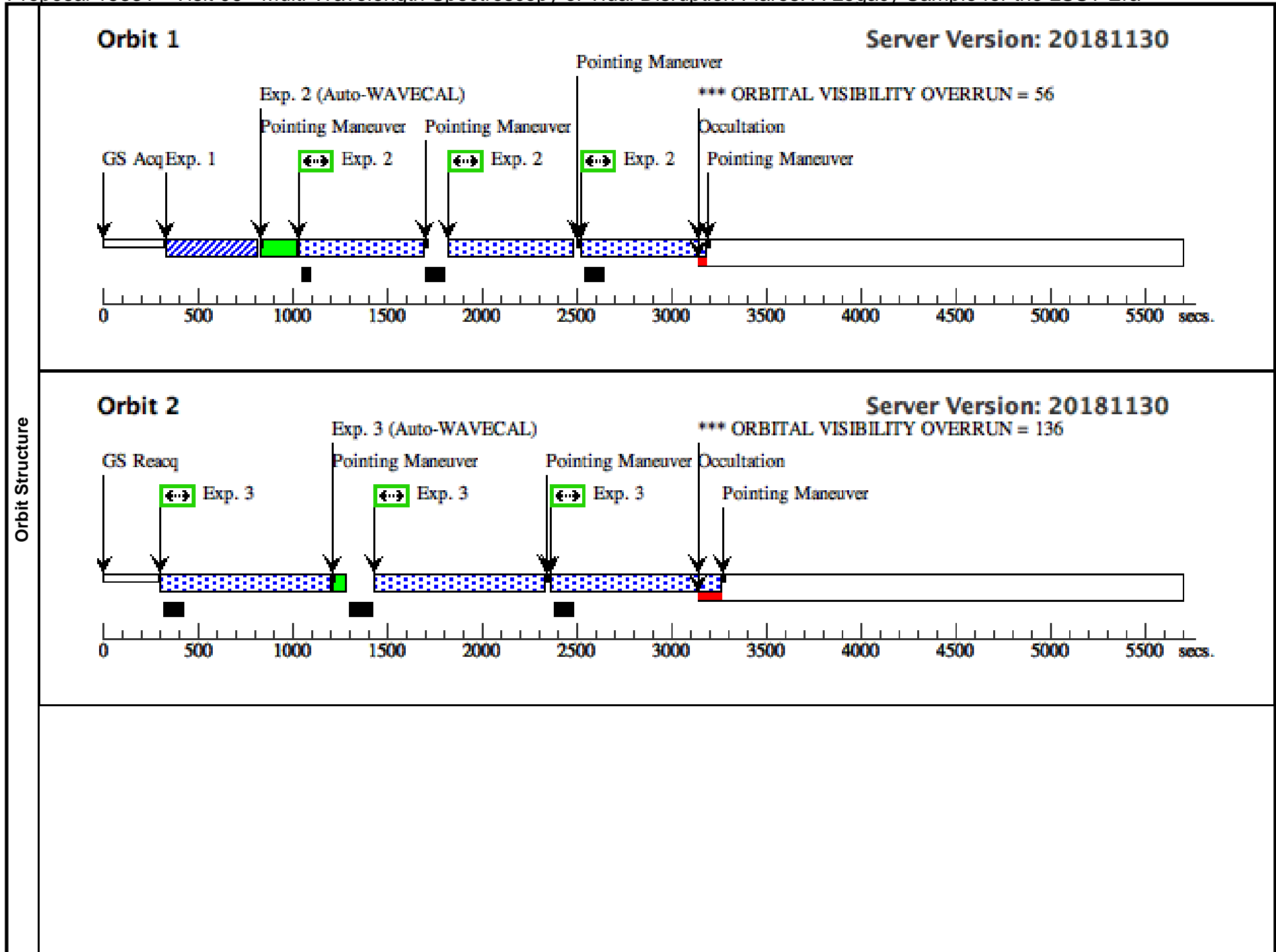

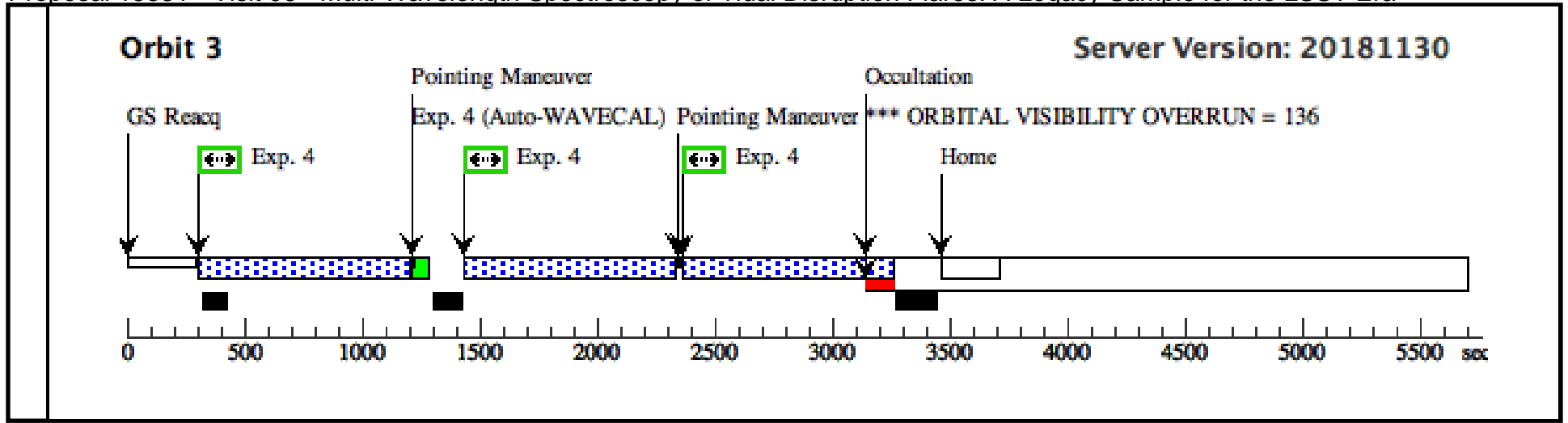

Proposal 15331 - Visit 07 - Multi-Wavelength Spectroscopy of Tidal Disruption Flares: A Legacy Sample for the LSST Era

Fri Jan 25 14:01:46 GMT 2019

Visit	Proposal 15331, Visit 07, completed Diagnostic Status: Warning Scientific Instruments: STIS/NUV-MAMA, STIS/CCD, STIS/FUV-MAMA Special Requirements: BETWEEN 27-AUG-2018:00:00:00 AND 07-SEP-2018:00:00:00; ON HOLD ; TOO RESPONSE TIME 21.0D <i>On Hold Comments: Awaiting ToO trigger</i>										
	(Visit 07) Warning (Orbit Planner): ORBITAL VISIBILITY OVERRUN (Visit 07) Warning (Orbit Planner): ORBITAL VISIBILITY OVERRUN										
Diagnosics											
Patterns	#	Primary Pattern				Secondary Pattern				Exposures	
	(1)	Pattern Type=STIS-ALONG-SLIT		Coordinate Frame=POS-TARG						(2), (3)	
		Purpose=DITHER		Pattern Orientation=90.0							
		Number Of Points=3		Angle Between Sides=							
		Point Spacing=0.4165		Center Pattern=false							
		Line Spacing=									
Fixed Targets	#	Name	Target Coordinates		Targ. Coord. Corrections		Fluxes		Miscellaneous		
	(8)	ZTF18AAJUPNT	RA: 15 33 8.0150 (233.2833958d) Dec: +44 32 8.20 (44.53561d) Equinox: J2000				V=19.0+/-0.1		Reference Frame: ICRS		
<i>Comments:</i> Category=GALAXY Description=[ACCRETION DISK, NUCLEUS]											
Exposures	#	Label (ETC Run)	Target	Config,Mode,Aperture	Spectral Els.	Opt. Params.	Special Reqs.	Groups	Exp. Time (Total)/[Actual Dur.]		Orbit
	1	(STIS.ta.118 6983)	(8) ZTF18AAJUPN T	STIS/CCD, ACQ, F28X50LP	MIRROR				45 Secs (45 Secs)		
									[=>]		[1]
	2	(STIS.sp.11 86984)	(8) ZTF18AAJUPN T	STIS/NUV-MAMA, ACCUM, 52X0.2	G230L 2376 A			Pattern 1, Exps 2-2 in Visit 07 (1)	709. Secs (2127 Secs)		
									[=>(Pattern 1)] [=>(Pattern 2)] [=>(Pattern 3)]		[1]
3	(STIS.sp.11 86984)	(8) ZTF18AAJUPN T	STIS/FUV-MAMA, ACCUM, 52X0.2	G140L 1425 A			Pattern 1, Exps 3-3 in Visit 07 (1)	953. Secs (2859 Secs)			
								[=>(Pattern 1)] [=>(Pattern 2)] [=>(Pattern 3)]		[2]	

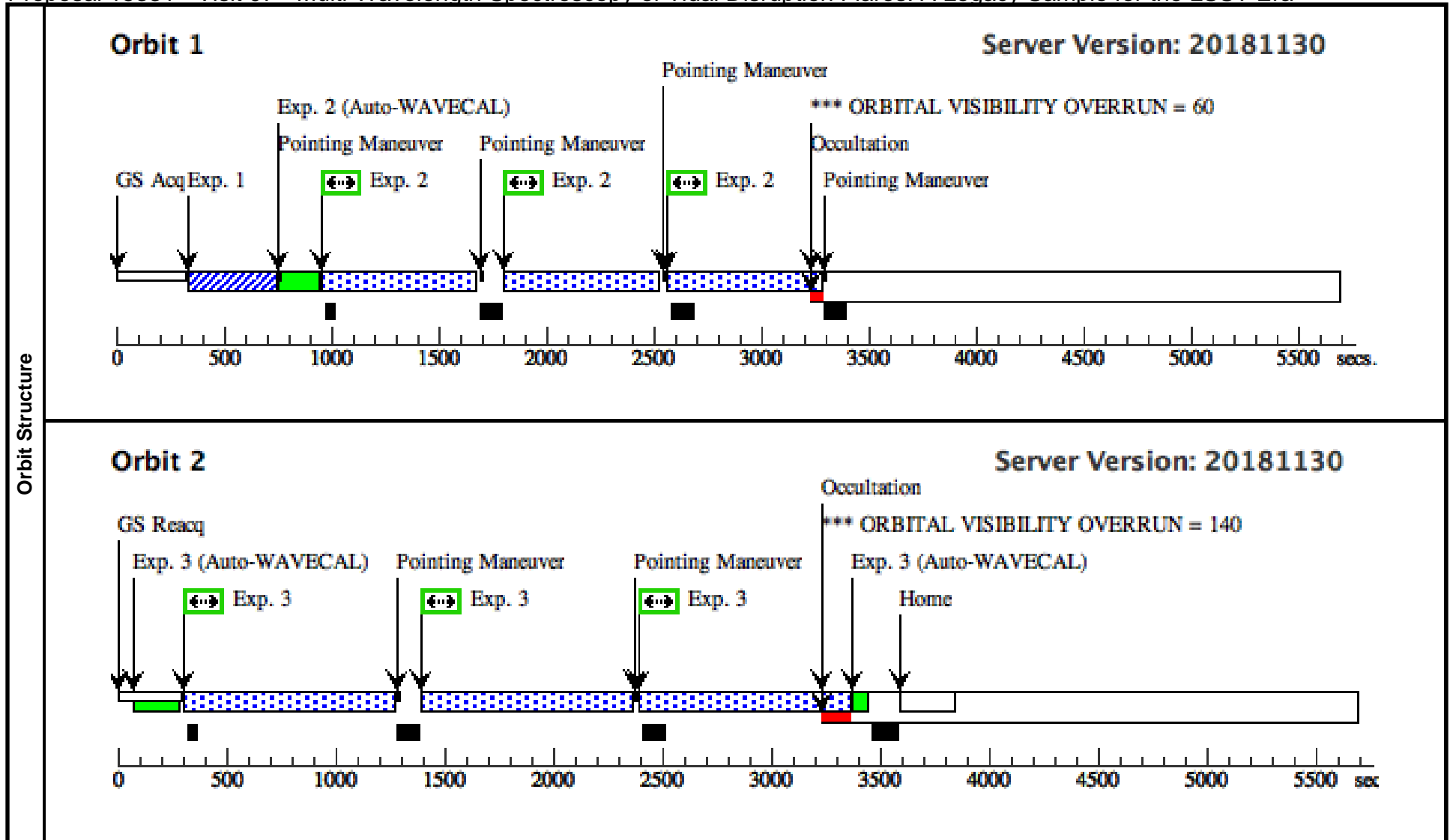

Proposal 15331 - Visit 08 - Multi-Wavelength Spectroscopy of Tidal Disruption Flares: A Legacy Sample for the LSST Era

Fri Jan 25 14:01:46 GMT 2019

Visit	Proposal 15331, Visit 08, failed Diagnostic Status: No Diagnostics Scientific Instruments: STIS/NUV-MAMA, STIS/CCD Special Requirements: BETWEEN 03-JAN-2019:00:00:00 AND 31-JAN-2019:00:00:00; ON HOLD <i>On Hold Comments: Awaiting ToO Trigger.</i>									
	Patterns	#	Primary Pattern			Secondary Pattern			Exposures	
		(1)	Pattern Type=STIS-ALONG-SLIT	Coordinate Frame=POS-TARG						
		Purpose=DITHER	Pattern Orientation=90.0							
		Number Of Points=3	Angle Between Sides=							
		Point Spacing=0.4165	Center Pattern=false							
		Line Spacing=								
Fixed Targets	#	Name	Target Coordinates	Targ. Coord. Corrections	Fluxes	Miscellaneous				
	(8)	ZTF18AAJUPNT	RA: 15 33 8.0150 (233.2833958d) Dec: +44 32 8.20 (44.53561d) Equinox: J2000		V=19.0+/-0.1	Reference Frame: ICRS				
	<i>Comments:</i> Category=GALAXY Description=[ACCRETION DISK, NUCLEUS]									
Exposures	#	Label (ETC Run)	Target	Config,Mode,Aperture	Spectral Els.	Opt. Params.	Special Reqs.	Groups	Exp. Time (Total)/[Actual Dur.]	Orbit
	1	(STIS.ta.100 3498)	(8) ZTF18AAJUPN T	STIS/CCD, ACQ, F28X50LP	MIRROR				45 Secs (45 Secs)	
									[==>]	[1]
	2	(STIS.sp.10 03499)	(8) ZTF18AAJUPN T	STIS/NUV-MAMA, ACCUM, 52X0.2	G230L 2376 A			Pattern 1, Exps 2-2 in Visit 08 (1)	625 Secs (1875 Secs)	
									[==>(Pattern 1)] [==>(Pattern 2)] [==>(Pattern 3)]	[1]
3	(STIS.sp.10 03500)	(8) ZTF18AAJUPN T	STIS/NUV-MAMA, ACCUM, 52X0.2	G230L 2376 A			Pattern 1, Exps 3-3 in Visit 08 (1)	834 Secs (2502 Secs)		
								[==>(Pattern 1)] [==>(Pattern 2)] [==>(Pattern 3)]	[2]	

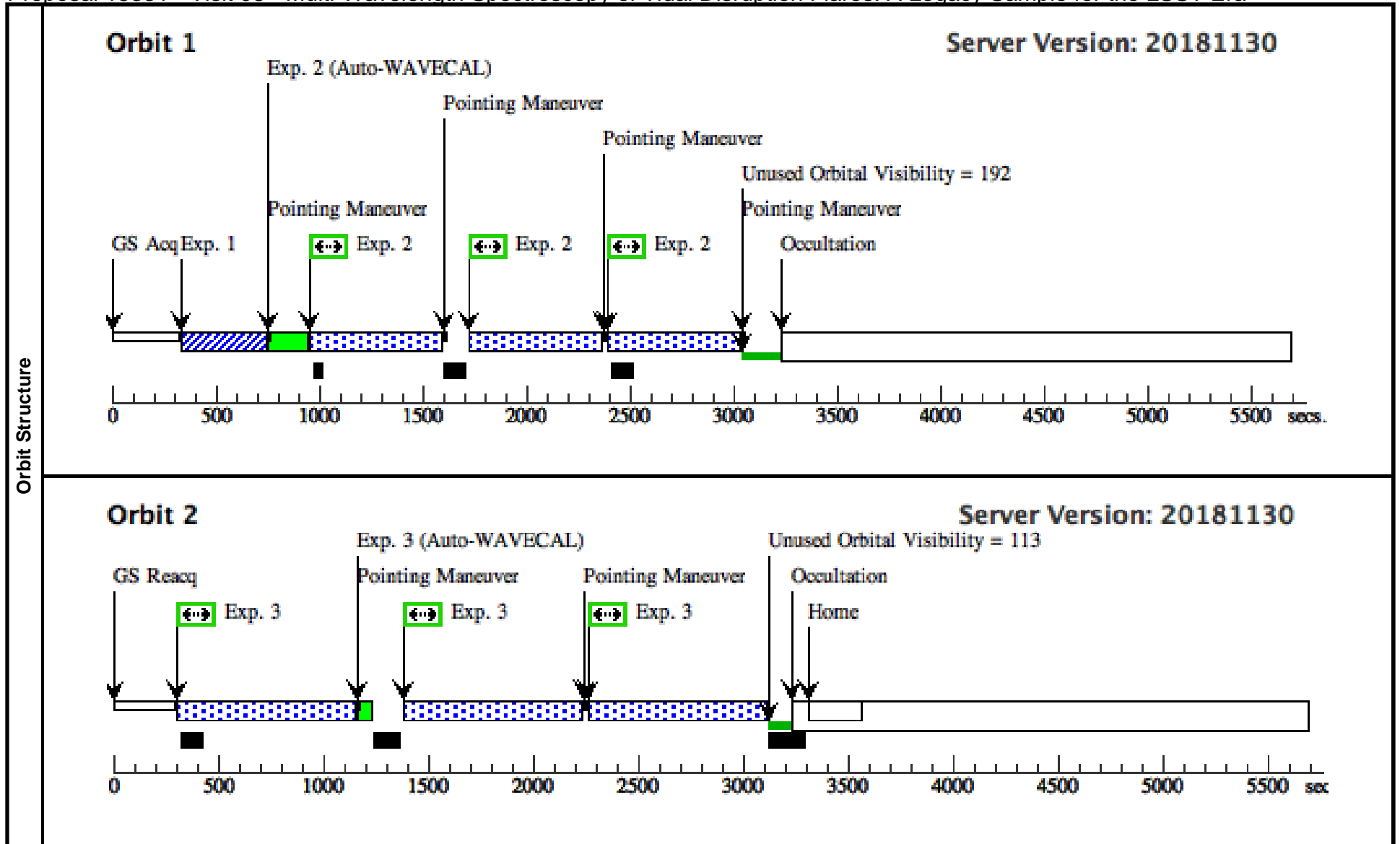

Proposal 15331 - Visit 58 - Multi-Wavelength Spectroscopy of Tidal Disruption Flares: A Legacy Sample for the LSST Era

Fri Jan 25 14:01:46 GMT 2019

Visit	Proposal 15331, Visit 58 Diagnostic Status: No Diagnostics Scientific Instruments: STIS/NUV-MAMA, STIS/CCD Special Requirements: (none) Comments: HOPR copy of visit 08									
	Patterns	#	Primary Pattern			Secondary Pattern			Exposures	
		(1)	Pattern Type=STIS-ALONG-SLIT	Coordinate Frame=POS-TARG						
		Purpose=DITHER	Pattern Orientation=90.0							
		Number Of Points=3	Angle Between Sides=							
		Point Spacing=0.4165	Center Pattern=false							
		Line Spacing=								
Fixed Targets	#	Name	Target Coordinates		Targ. Coord. Corrections		Fluxes		Miscellaneous	
	(8)	ZTF18AAJUPNT	RA: 15 33 8.0150 (233.2833958d)	Dec: +44 32 8.20 (44.53561d)			V=19.0+/-0.1		Reference Frame: ICRS	
		Comments: Category=GALAXY Description=[ACCRETION DISK, NUCLEUS]								
Exposures	#	Label (ETC Run)	Target	Config,Mode,Aperture	Spectral Els.	Opt. Params.	Special Reqs.	Groups	Exp. Time (Total)/[Actual Dur.]	Orbit
	1	(STIS.ta.100 3498)	(8) ZTF18AAJUPN T	STIS/CCD, ACQ, F28X50LP	MIRROR				45 Secs (45 Secs)	
									[==>]	[1]
	2	(STIS.sp.10 03499)	(8) ZTF18AAJUPN T	STIS/NUV-MAMA, ACCUM, 52X0.2	G230L 2376 A			Pattern 1, Exps 2-2 in Visit 58 (1)	625 Secs (1875 Secs)	
									[==>(Pattern 1)] [==>(Pattern 2)] [==>(Pattern 3)]	[1]
3	(STIS.sp.10 03500)	(8) ZTF18AAJUPN T	STIS/NUV-MAMA, ACCUM, 52X0.2	G230L 2376 A			Pattern 1, Exps 3-3 in Visit 58 (1)	834 Secs (2502 Secs)		
								[==>(Pattern 1)] [==>(Pattern 2)] [==>(Pattern 3)]	[2]	

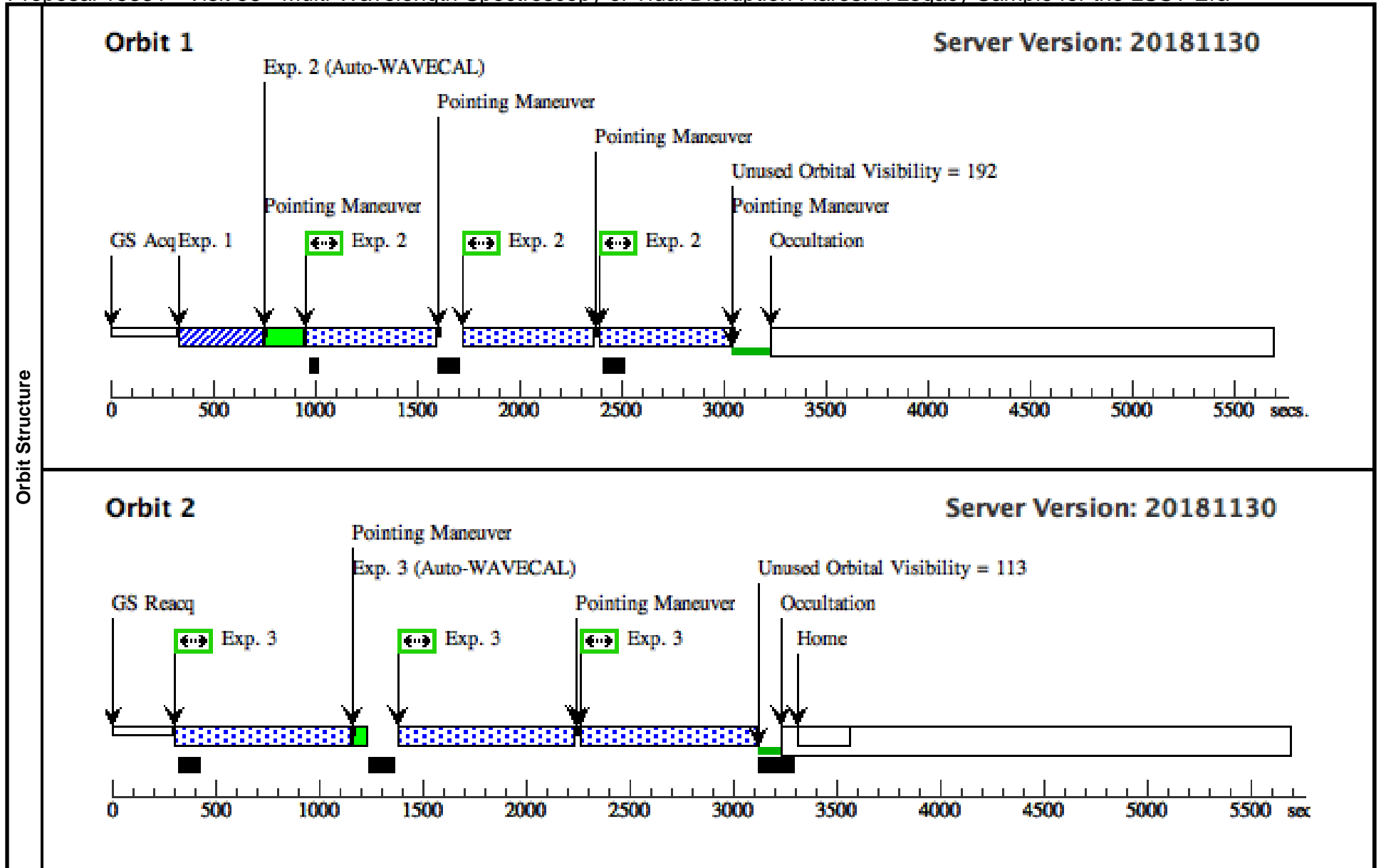

Proposal 15331 - Visit 09 - Multi-Wavelength Spectroscopy of Tidal Disruption Flares: A Legacy Sample for the LSST Era

Fri Jan 25 14:01:46 GMT 2019

Visit	Proposal 15331, Visit 09, completed Diagnostic Status: No Diagnostics Scientific Instruments: STIS/CCD, STIS/FUV-MAMA Special Requirements: BETWEEN 03-JAN-2019:00:00:00 AND 31-JAN-2019:00:00:00; ON HOLD <i>On Hold Comments: Awaiting ToO Trigger.</i>									
	Patterns	#	Primary Pattern			Secondary Pattern			Exposures	
		(1)	Pattern Type=STIS-ALONG-SLIT	Coordinate Frame=POS-TARG						
		Purpose=DITHER	Pattern Orientation=90.0							
		Number Of Points=3	Angle Between Sides=							
		Point Spacing=0.4165	Center Pattern=false							
		Line Spacing=								
Fixed Targets	#	Name	Target Coordinates	Targ. Coord. Corrections	Fluxes	Miscellaneous				
	(8)	ZTF18AAJUPNT	RA: 15 33 8.0150 (233.2833958d) Dec: +44 32 8.20 (44.53561d) Equinox: J2000		V=19.0+/-0.1	Reference Frame: ICRS				
	<i>Comments:</i> Category=GALAXY Description=[ACCRETION DISK, NUCLEUS]									
Exposures	#	Label (ETC Run)	Target	Config,Mode,Aperture	Spectral Els.	Opt. Params.	Special Reqs.	Groups	Exp. Time (Total)/[Actual Dur.]	Orbit
	1	(STIS.ta.100 3498)	(8) ZTF18AAJUPN T	STIS/CCD, ACQ, F28X50LP	MIRROR				45 Secs (45 Secs)	
									[==>]	[1]
	2	(STIS.sp.10 03504)	(8) ZTF18AAJUPN T	STIS/FUV-MAMA, ACCUM, 52X0.2	G140L 1425 A			Pattern 1, Exps 2-2 in Visit 09 (1)	625. Secs (1875 Secs)	
									[==>(Pattern 1)] [==>(Pattern 2)] [==>(Pattern 3)]	[1]
3	(STIS.sp.10 03504)	(8) ZTF18AAJUPN T	STIS/FUV-MAMA, ACCUM, 52X0.2	G140L 1425 A			Pattern 1, Exps 3-3 in Visit 09 (1)	834. Secs (2502 Secs)		
								[==>(Pattern 1)] [==>(Pattern 2)] [==>(Pattern 3)]	[2]	

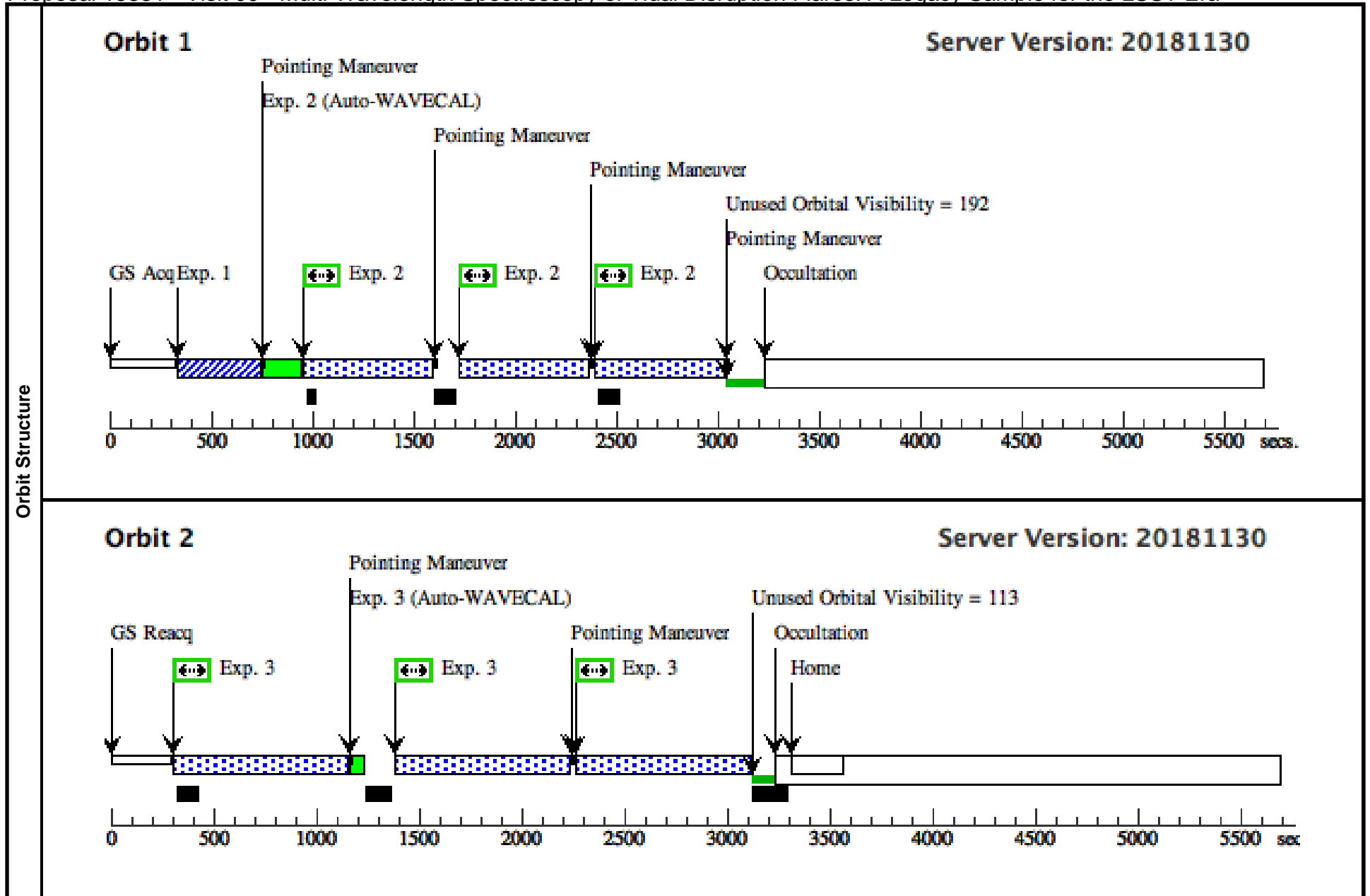

Proposal 15331 - Visit 10 - Multi-Wavelength Spectroscopy of Tidal Disruption Flares: A Legacy Sample for the LSST Era

Fri Jan 25 14:01:46 GMT 2019

Visit	Proposal 15331, Visit 10, scheduling Diagnostic Status: No Diagnostics Scientific Instruments: STIS/NUV-MAMA, STIS/CCD Special Requirements: BETWEEN 01-MAR-2019:00:00:00 AND 31-MAR-2019:00:00:00; ON HOLD <i>On Hold Comments: Awaiting ToO Trigger.</i>									
	Patterns	#	Primary Pattern			Secondary Pattern			Exposures	
		(1)	Pattern Type=STIS-ALONG-SLIT	Coordinate Frame=POS-TARG						
		Purpose=DITHER	Pattern Orientation=90.0							
		Number Of Points=3	Angle Between Sides=							
		Point Spacing=0.4165	Center Pattern=false							
		Line Spacing=								
Fixed Targets	#	Name	Target Coordinates	Targ. Coord. Corrections	Fluxes	Miscellaneous				
	(8)	ZTF18AAJUPNT	RA: 15 33 8.0150 (233.2833958d) Dec: +44 32 8.20 (44.53561d) Equinox: J2000		V=19.0+/-0.1	Reference Frame: ICRS				
	<i>Comments:</i> Category=GALAXY Description=[ACCRETION DISK, NUCLEUS]									
Exposures	#	Label (ETC Run)	Target	Config,Mode,Aperture	Spectral Els.	Opt. Params.	Special Reqs.	Groups	Exp. Time (Total)/[Actual Dur.]	Orbit
	1	(STIS.ta.100 3503)	(8) ZTF18AAJUPN T	STIS/CCD, ACQ, F28X50LP	MIRROR				45 Secs (45 Secs)	
									[==>]	[1]
	2	(STIS.sp.10 03505)	(8) ZTF18AAJUPN T	STIS/NUV-MAMA, ACCUM, 52X0.2	G230L 2376 A			Pattern 1, Exps 2-2 in Visit 10 (1)	625. Secs (1875 Secs)	
									[==>(Pattern 1)] [==>(Pattern 2)] [==>(Pattern 3)]	[1]
3	(STIS.sp.10 03505)	(8) ZTF18AAJUPN T	STIS/NUV-MAMA, ACCUM, 52X0.2	G230L 2376 A			Pattern 1, Exps 3-3 in Visit 10 (1)	834. Secs (2502 Secs)		
								[==>(Pattern 1)] [==>(Pattern 2)] [==>(Pattern 3)]	[2]	

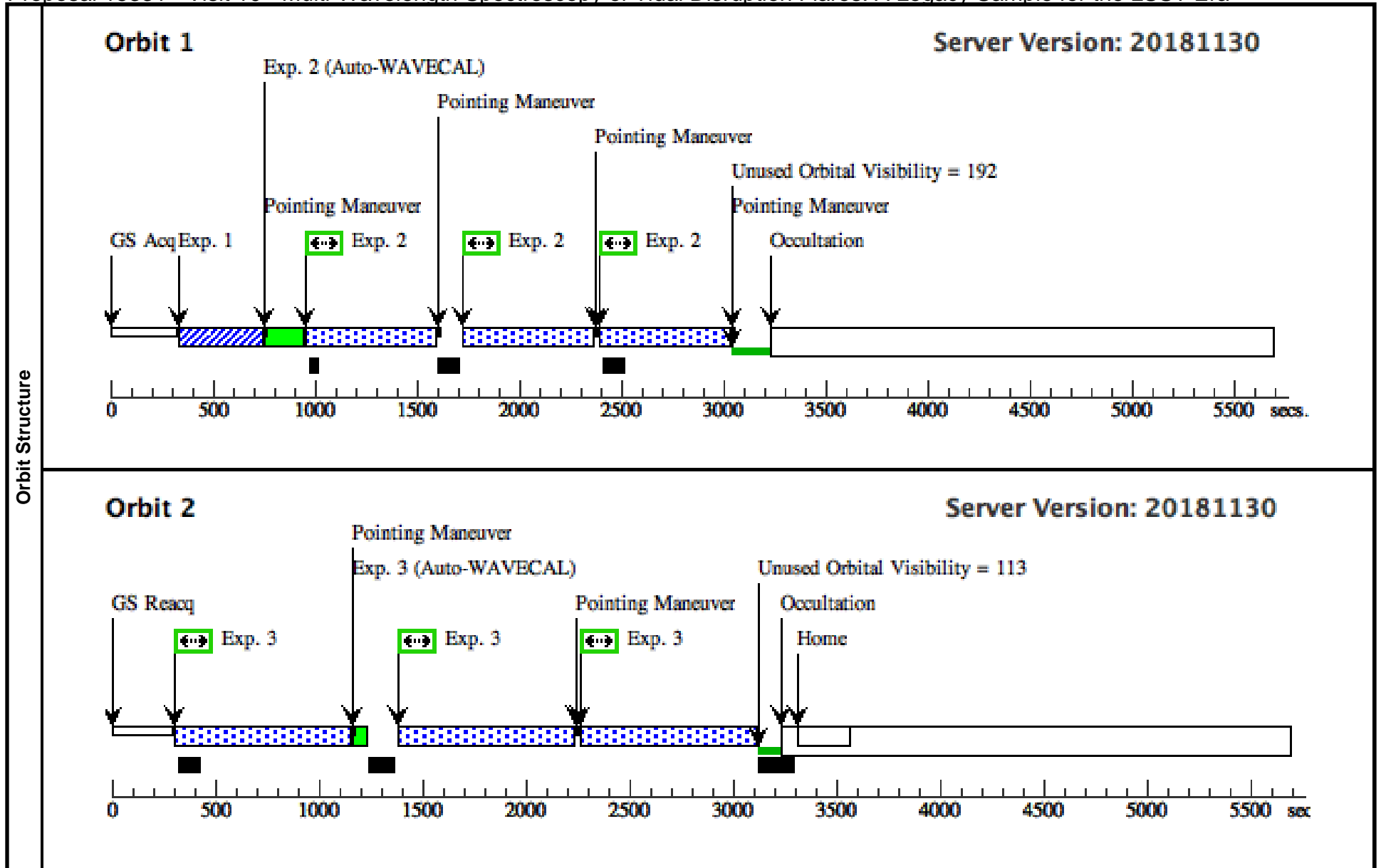

Proposal 15331 - Visit 11 - Multi-Wavelength Spectroscopy of Tidal Disruption Flares: A Legacy Sample for the LSST Era

Fri Jan 25 14:01:46 GMT 2019

Visit	Proposal 15331, Visit 11, scheduling Diagnostic Status: No Diagnostics Scientific Instruments: STIS/CCD, STIS/FUV-MAMA Special Requirements: BETWEEN 01-MAR-2019:00:00:00 AND 31-MAR-2019:00:00:00; ON HOLD <i>On Hold Comments: Awaiting ToO Trigger.</i>									
	Patterns	#	Primary Pattern			Secondary Pattern			Exposures	
		(1)	Pattern Type=STIS-ALONG-SLIT	Coordinate Frame=POS-TARG					(2), (3), (4)	
		Purpose=DITHER	Pattern Orientation=90.0							
		Number Of Points=3	Angle Between Sides=							
		Point Spacing=0.4165	Center Pattern=false							
		Line Spacing=								
Fixed Targets	#	Name	Target Coordinates	Targ. Coord. Corrections	Fluxes	Miscellaneous				
	(8)	ZTF18AAJUPNT	RA: 15 33 8.0150 (233.2833958d) Dec: +44 32 8.20 (44.53561d) Equinox: J2000		V=19.0+/-0.1	Reference Frame: ICRS				
	<i>Comments:</i> Category=GALAXY Description=[ACCRETION DISK, NUCLEUS]									
Exposures	#	Label (ETC Run)	Target	Config,Mode,Aperture	Spectral Els.	Opt. Params.	Special Reqs.	Groups	Exp. Time (Total)/[Actual Dur.]	Orbit
	1	(STIS.ta.100 3507)	(8) ZTF18AAJUPN T	STIS/CCD, ACQ, F28X50LP	MIRROR				45 Secs (45 Secs)	
									[==>]	[1]
	2	(STIS.sp.10 03509)	(8) ZTF18AAJUPN T	STIS/FUV-MAMA, ACCUM, 52X0.2	G140L 1425 A			Pattern 1, Exps 2-2 in Visit 11 (1)	625. Secs (1875 Secs)	
									[==>(Pattern 1)] [==>(Pattern 2)] [==>(Pattern 3)]	[1]
3	(STIS.sp.10 03509)	(8) ZTF18AAJUPN T	STIS/FUV-MAMA, ACCUM, 52X0.2	G140L 1425 A			Pattern 1, Exps 3-3 in Visit 11 (1)	834. Secs (2502 Secs)		
								[==>(Pattern 1)] [==>(Pattern 2)] [==>(Pattern 3)]	[2]	
4	(STIS.sp.10 03509)	(8) ZTF18AAJUPN T	STIS/FUV-MAMA, ACCUM, 52X0.2	G140L 1425 A			Pattern 1, Exps 4-4 in Visit 11 (1)	834. Secs (2502 Secs)		
								[==>(Pattern 1)] [==>(Pattern 2)] [==>(Pattern 3)]	[3]	

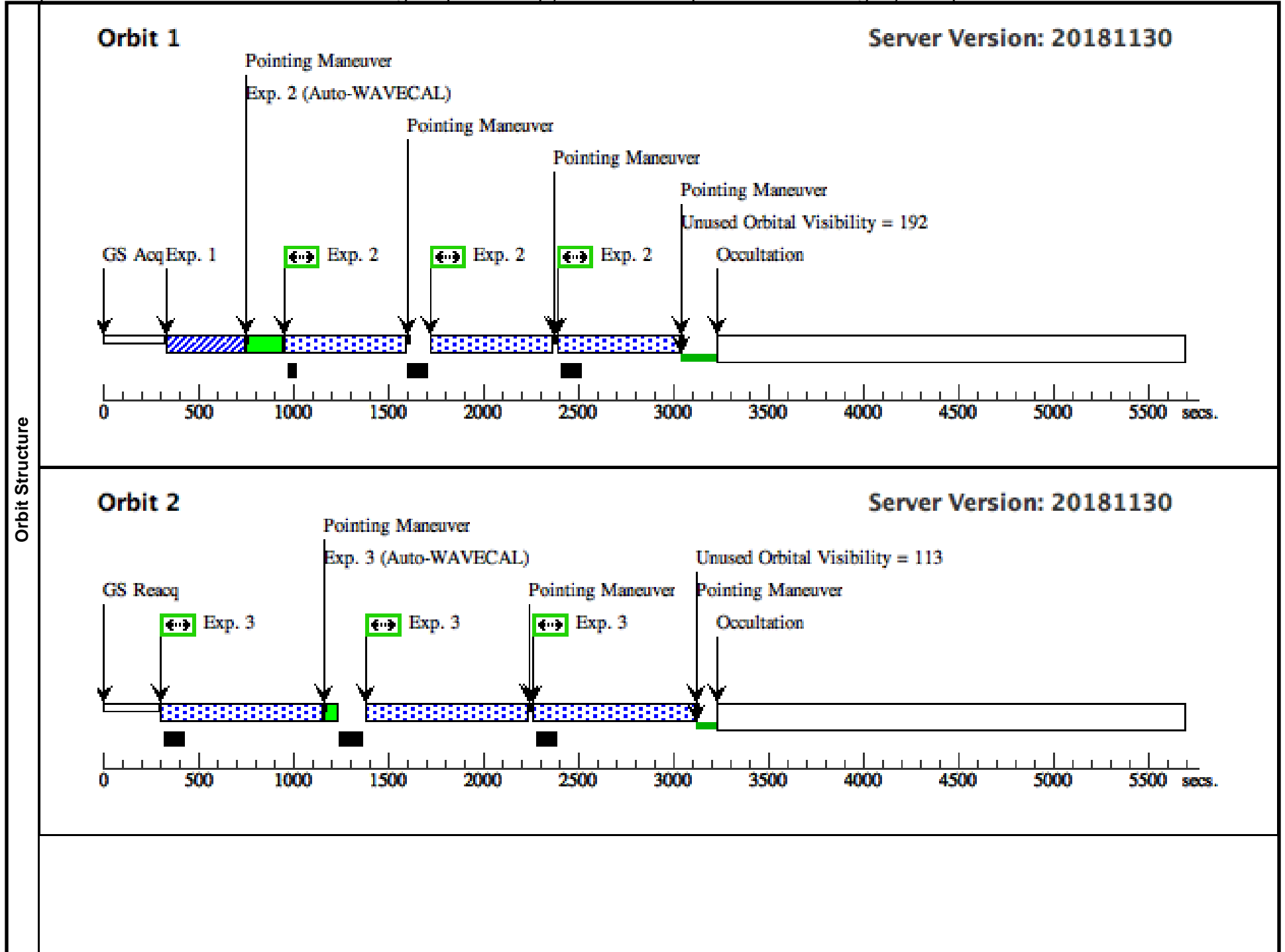

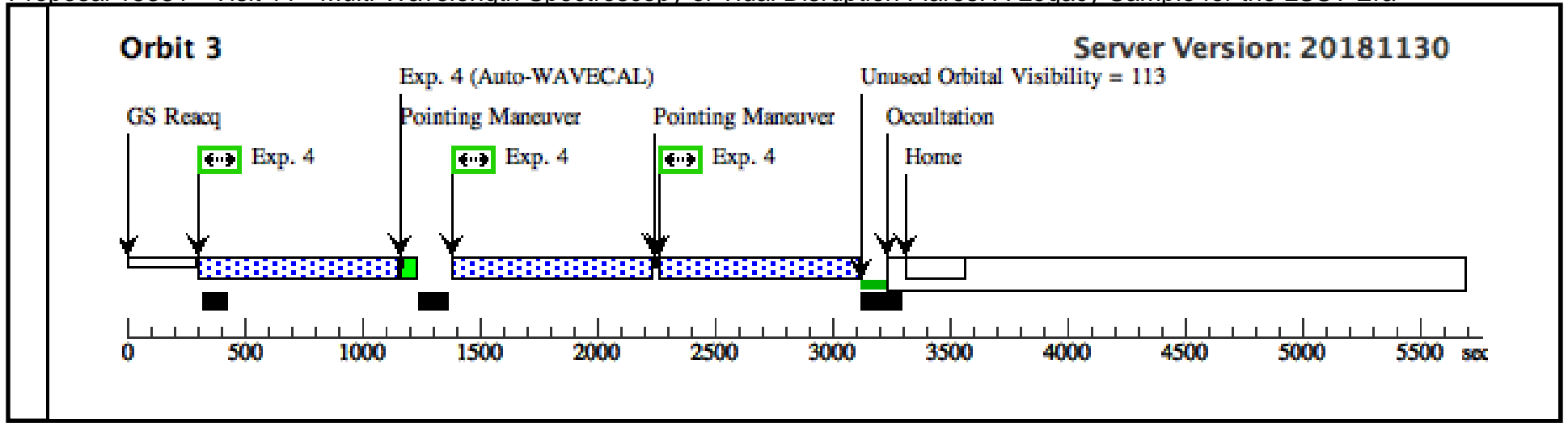

Proposal 15331 - Visit 12 - Multi-Wavelength Spectroscopy of Tidal Disruption Flares: A Legacy Sample for the LSST Era

Fri Jan 25 14:01:47 GMT 2019

Visit	Proposal 15331, Visit 12, withdrawn Diagnostic Status: Warning Scientific Instruments: STIS/CCD, STIS/FUV-MAMA Special Requirements: ON HOLD <i>On Hold Comments: Awaiting ToO Trigger.</i>										
	(Visit 12) Warning (Orbit Planner): ORBITAL VISIBILITY OVERRUN (Visit 12) Warning (Orbit Planner): ORBITAL VISIBILITY OVERRUN (Visit 12) Warning (Orbit Planner): ORBITAL VISIBILITY OVERRUN										
Diagnosics											
Patterns	#	Primary Pattern				Secondary Pattern				Exposures	
	(1)	Pattern Type=STIS-ALONG-SLIT		Coordinate Frame=POS-TARG						(2), (3), (4)	
		Purpose=DITHER		Pattern Orientation=90.0							
		Number Of Points=3		Angle Between Sides=							
		Point Spacing=0.4165		Center Pattern=false							
		Line Spacing=									
Generic Targets	#	Name	Criteria			Description					
	(2)	TDF2	Tidal Disruption Flare			ACCRETION DISK NUCLEUS					
<i>Comments: Nuclear transient not obviously AGN or supernova at z <- 0.3.</i>											
Exposures	#	Label (ETC Run)	Target	Config,Mode,Aperture	Spectral Els.	Opt. Params.	Special Reqs.	Groups	Exp. Time (Total)/[Actual Dur.]		Orbit
	1	(STIS.ta.100 3507)	(2) TDF2	STIS/CCD, ACQ, 50CCD	MIRROR				60 Secs (60 Secs)		
										[==>]	[1]
	2	(STIS.sp.10 03510)	(2) TDF2	STIS/FUV-MAMA, ACCUM, 52X0.2	G140L 1425 A			Pattern 1, Exps 2-2 in Visit 12 (1)	650. Secs (1950 Secs)		
										[==>(Pattern 1)]	
									[==>(Pattern 2)]	[1]	
									[==>(Pattern 3)]		
3	(STIS.sp.10 03510)	(2) TDF2	STIS/FUV-MAMA, ACCUM, 52X0.2	G140L 1425 A			Pattern 1, Exps 3-3 in Visit 12 (1)	885. Secs (2655 Secs)			
									[==>(Pattern 1)]		
									[==>(Pattern 2)]	[2]	
									[==>(Pattern 3)]		
4	(STIS.sp.10 03510)	(2) TDF2	STIS/FUV-MAMA, ACCUM, 52X0.2	G140L 1425 A			Pattern 1, Exps 4-4 in Visit 12 (1)	885. Secs (2655 Secs)			
									[==>(Pattern 1)]		
									[==>(Pattern 2)]	[3]	
									[==>(Pattern 3)]		

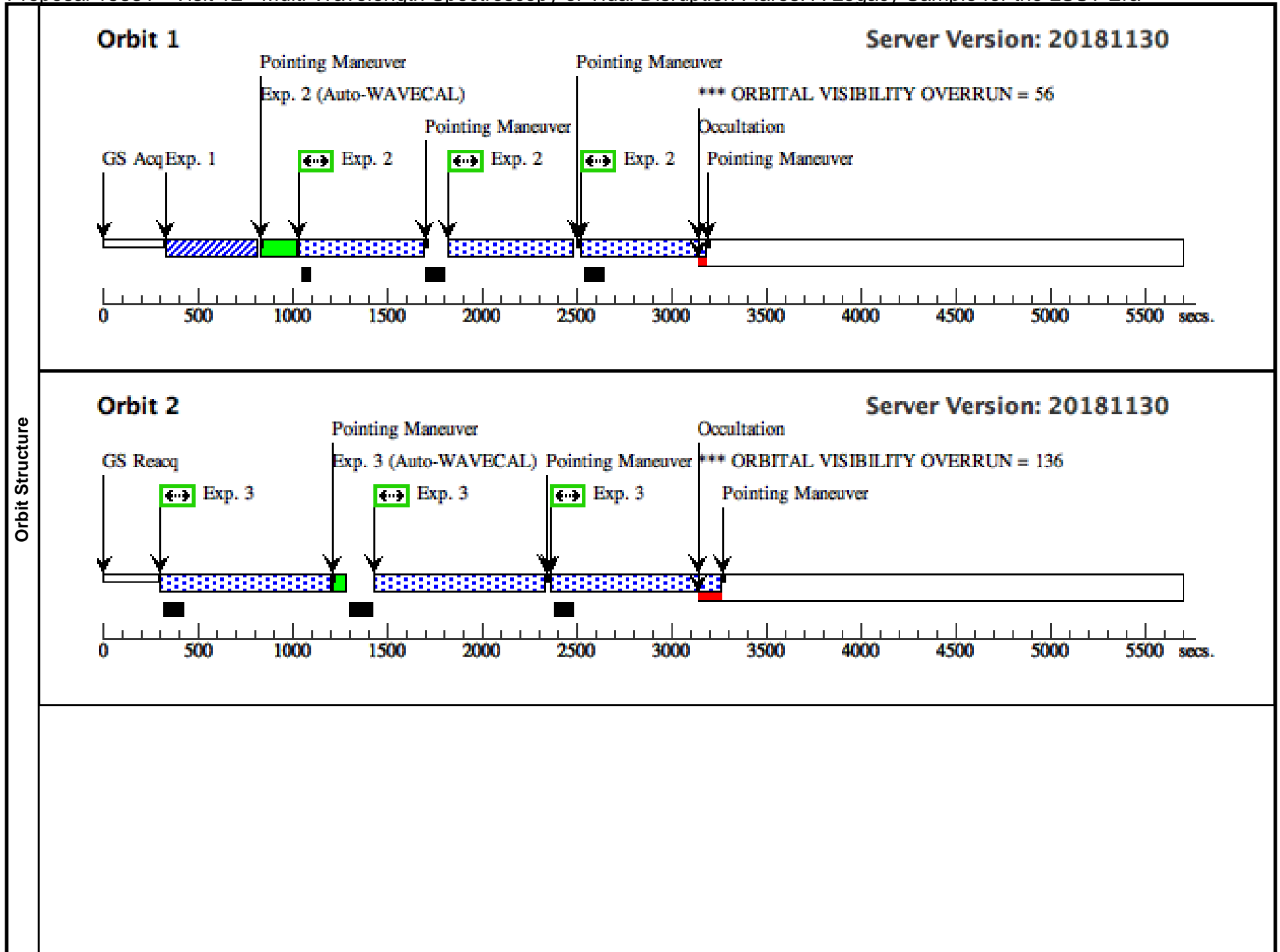

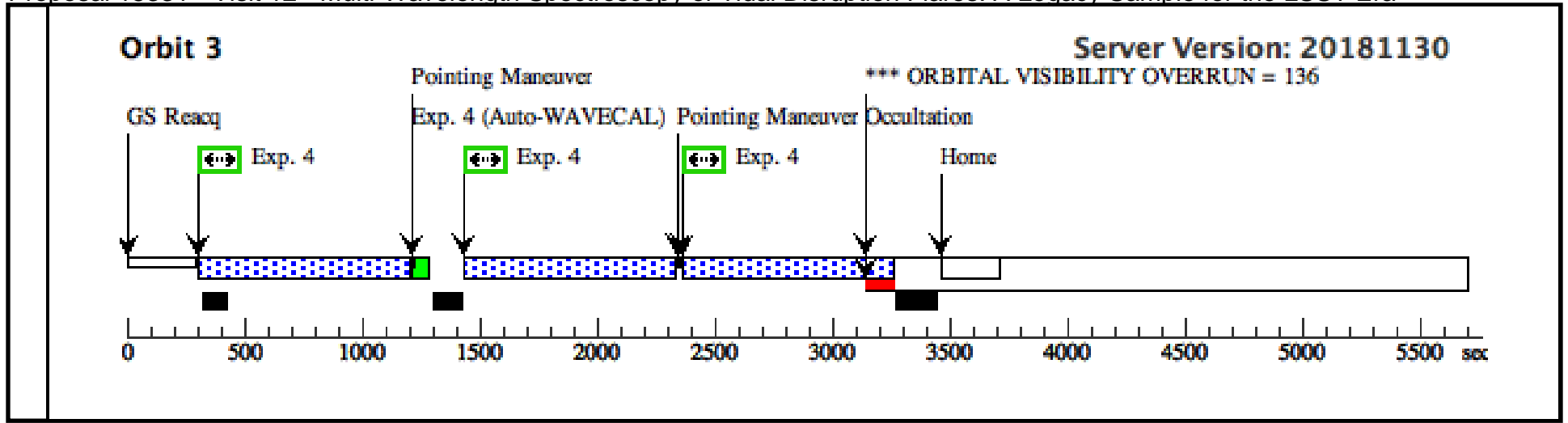

Proposal 15331 - Visit 13 - Multi-Wavelength Spectroscopy of Tidal Disruption Flares: A Legacy Sample for the LSST Era

Fri Jan 25 14:01:47 GMT 2019

Visit	Proposal 15331, Visit 13, withdrawn Diagnostic Status: Warning Scientific Instruments: STIS/NUV-MAMA, STIS/CCD, STIS/FUV-MAMA Special Requirements: ON HOLD ; TOO RESPONSE TIME 21.0D <i>On Hold Comments: Awaiting ToO trigger</i>										
	(Visit 13) Warning (Orbit Planner): ORBITAL VISIBILITY OVERRUN (Visit 13) Warning (Orbit Planner): ORBITAL VISIBILITY OVERRUN										
Diagnosics											
Patterns	#	Primary Pattern				Secondary Pattern				Exposures	
	(1)	Pattern Type=STIS-ALONG-SLIT		Coordinate Frame=POS-TARG						(2), (3)	
		Purpose=DITHER		Pattern Orientation=90.0							
		Number Of Points=3		Angle Between Sides=							
		Point Spacing=0.4165		Center Pattern=false							
		Line Spacing=									
Generic Targets	#	Name		Criteria		Description					
	(3)	TDF3		Tidal Disruption Flare		ACCRETION DISK NUCLEUS					
<i>Comments: Nuclear transient not obviously AGN or supernova at z <~ 0.3.</i>											
Exposures	#	Label (ETC Run)	Target	Config,Mode,Aperture	Spectral Els.	Opt. Params.	Special Reqs.	Groups	Exp. Time (Total)/[Actual Dur.]		Orbit
	1	(STIS.ta.100 3498)	(3) TDF3	STIS/CCD, ACQ, F28X50LP	MIRROR				45 Secs (45 Secs)		
										[=>]	[1]
	2	(STIS.sp.10 03499)	(3) TDF3	STIS/NUV-MAMA, ACCUM, 52X0.2	G230L 2376 A			Pattern 1, Exps 2-2 in Visit 13 (1)	674. Secs (2022 Secs)		
										[=>(Pattern 1)]	[1]
									[=>(Pattern 2)]		
									[=>(Pattern 3)]		
3	(STIS.sp.10 03500)	(3) TDF3	STIS/FUV-MAMA, ACCUM, 52X0.2	G140L 1425 A			Pattern 1, Exps 3-3 in Visit 13 (1)	920. Secs (2760 Secs)			
									[=>(Pattern 1)]		
									[=>(Pattern 2)]	[2]	
									[=>(Pattern 3)]		

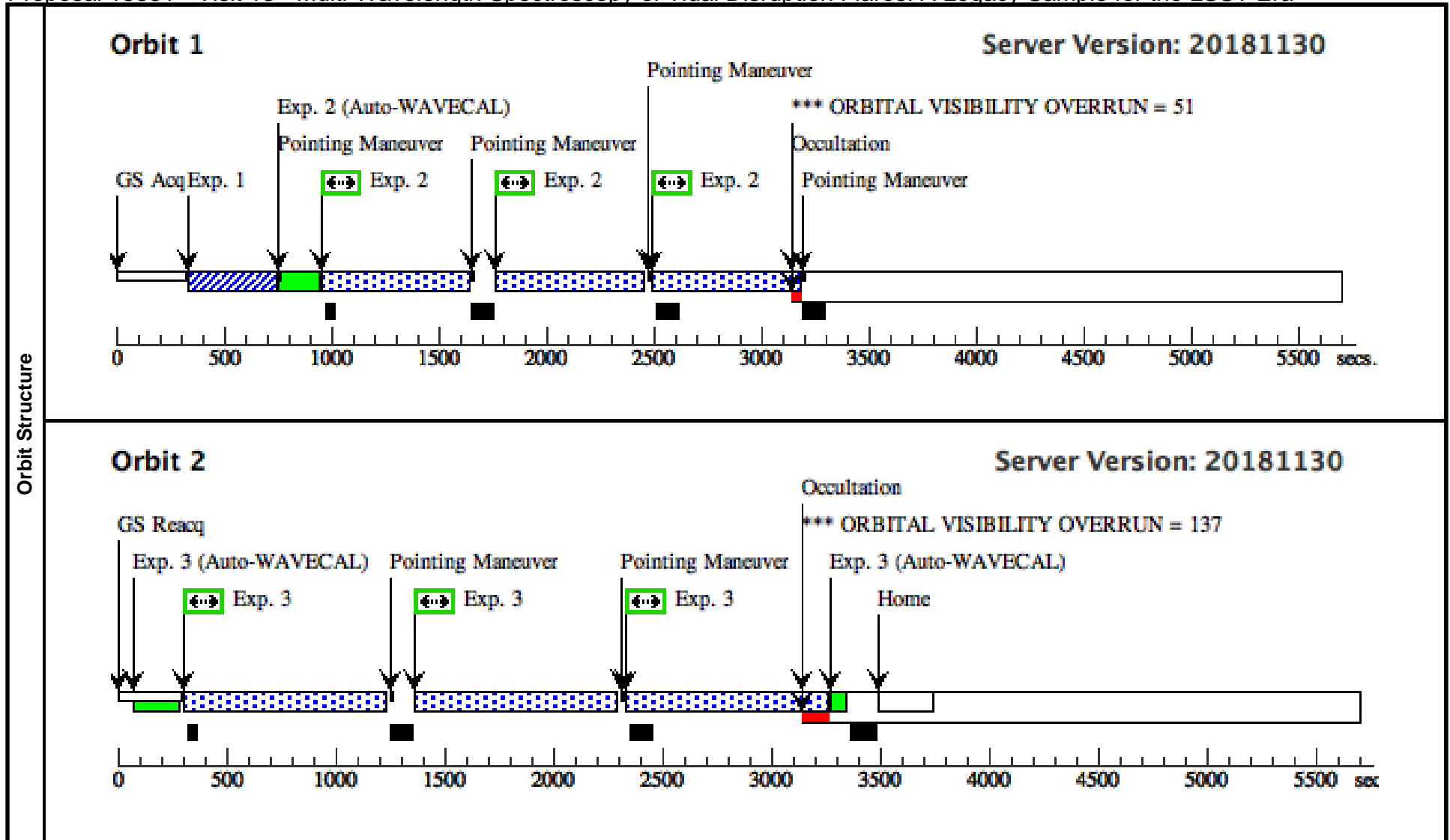

Proposal 15331 - Visit 14 - Multi-Wavelength Spectroscopy of Tidal Disruption Flares: A Legacy Sample for the LSST Era

Fri Jan 25 14:01:47 GMT 2019

Visit	Proposal 15331, Visit 14, withdrawn Diagnostic Status: Warning Scientific Instruments: STIS/NUV-MAMA, STIS/CCD, STIS/FUV-MAMA Special Requirements: AFTER 13 BY 20 D TO 40 D; ON HOLD <i>On Hold Comments: Awaiting ToO Trigger.</i>									
	(Visit 14) Warning (Orbit Planner): ORBITAL VISIBILITY OVERRUN (Visit 14) Warning (Orbit Planner): ORBITAL VISIBILITY OVERRUN									
Diagnosics										
Patterns	#	Primary Pattern				Secondary Pattern				Exposures
	(1)	Pattern Type=STIS-ALONG-SLIT		Coordinate Frame=POS-TARG						(2), (3)
		Purpose=DITHER		Pattern Orientation=90.0						
		Number Of Points=3		Angle Between Sides=						
		Point Spacing=0.4165		Center Pattern=false						
		Line Spacing=								
Generic Targets	#	Name	Criteria	Description						
	(3)	TDF3	Tidal Disruption Flare	ACCRETION DISK NUCLEUS						
									<i>Comments: Nuclear transient not obviously AGN or supernova at z <~ 0.3.</i>	
Exposures	#	Label (ETC Run)	Target	Config,Mode,Aperture	Spectral Els.	Opt. Params.	Special Reqs.	Groups	Exp. Time (Total)/[Actual Dur.]	Orbit
	1	(STIS.ta.100 3498)	(3) TDF3	STIS/CCD, ACQ, F28X50LP	MIRROR				45 Secs (45 Secs)	
										[==>]
										[1]
	2	(STIS.sp.10 03499)	(3) TDF3	STIS/NUV-MAMA, ACCUM, 52X0.2	G230L 2376 A			Pattern 1, Exps 2-2 in Visit 14 (1)	674. Secs (2022 Secs)	
									[==>(Pattern 1)]	
									[==>(Pattern 2)]	
									[==>(Pattern 3)]	
									[1]	
3	(STIS.sp.10 03500)	(3) TDF3	STIS/FUV-MAMA, ACCUM, 52X0.2	G140L 1425 A			Pattern 1, Exps 3-3 in Visit 14 (1)	920. Secs (2760 Secs)		
									[==>(Pattern 1)]	
									[==>(Pattern 2)]	
									[==>(Pattern 3)]	
									[2]	

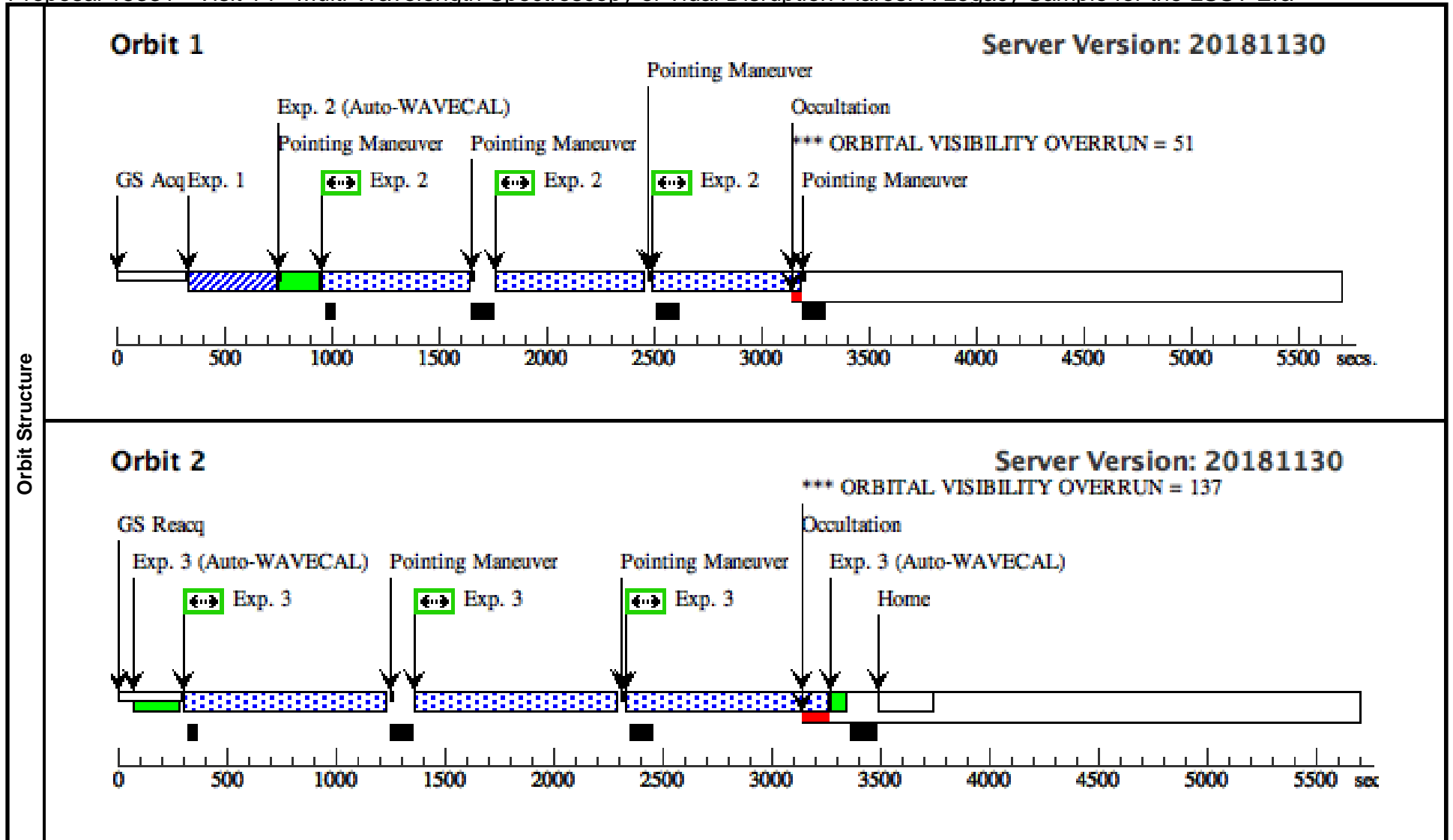

Proposal 15331 - Visit 15 - Multi-Wavelength Spectroscopy of Tidal Disruption Flares: A Legacy Sample for the LSST Era

Fri Jan 25 14:01:47 GMT 2019

Visit	Proposal 15331, Visit 15, withdrawn Diagnostic Status: Warning Scientific Instruments: STIS/NUV-MAMA, STIS/CCD Special Requirements: AFTER 13 BY 75 D TO 105 D; ON HOLD <i>On Hold Comments: Awaiting ToO Trigger.</i>										
	(Visit 15) Warning (Orbit Planner): ORBITAL VISIBILITY OVERRUN (Visit 15) Warning (Orbit Planner): ORBITAL VISIBILITY OVERRUN										
Diagnosics											
Patterns	#	Primary Pattern				Secondary Pattern				Exposures	
	(1)	Pattern Type=STIS-ALONG-SLIT		Coordinate Frame=POS-TARG						(2), (3)	
		Purpose=DITHER		Pattern Orientation=90.0							
		Number Of Points=3		Angle Between Sides=							
		Point Spacing=0.4165		Center Pattern=false							
		Line Spacing=									
Generic Targets	#	Name		Criteria		Description					
	(3)	TDF3		Tidal Disruption Flare		ACCRETION DISK NUCLEUS					
<i>Comments: Nuclear transient not obviously AGN or supernova at z <~ 0.3.</i>											
Exposures	#	Label (ETC Run)	Target	Config,Mode,Aperture	Spectral Els.	Opt. Params.	Special Reqs.	Groups	Exp. Time (Total)/[Actual Dur.]		Orbit
	1	(STIS.ta.100 3503)	(3) TDF3	STIS/CCD, ACQ, F28X50LP	MIRROR				100 Secs (100 Secs)		
										[==>]	[1]
	2	(STIS.sp.10 03504)	(3) TDF3	STIS/NUV-MAMA, ACCUM, 52X0.2	G230L 2376 A			Pattern 1, Exps 2-2 in Visit 15 (1)	600. Secs (1800 Secs)		
										[==>(Pattern 1)]	[1]
									[==>(Pattern 2)]		
									[==>(Pattern 3)]		
3	(STIS.sp.10 03504)	(3) TDF3	STIS/NUV-MAMA, ACCUM, 52X0.2	G230L 2376 A			Pattern 1, Exps 3-3 in Visit 15 (1)	885. Secs (2655 Secs)			
									[==>(Pattern 1)]		
									[==>(Pattern 2)]	[2]	
									[==>(Pattern 3)]		

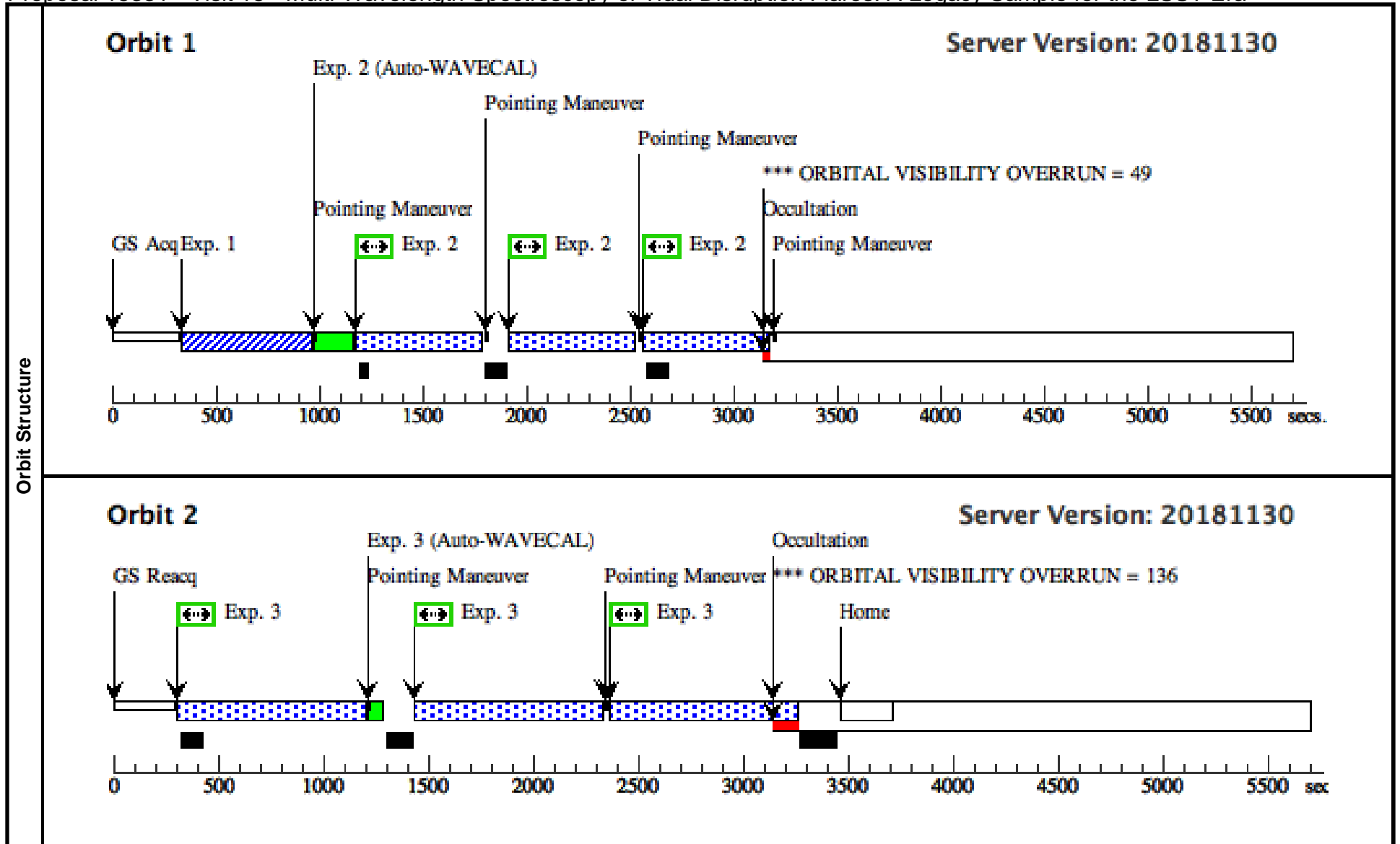

Proposal 15331 - Visit 16 - Multi-Wavelength Spectroscopy of Tidal Disruption Flares: A Legacy Sample for the LSST Era

Fri Jan 25 14:01:47 GMT 2019

Visit	Proposal 15331, Visit 16, withdrawn Diagnostic Status: Warning Scientific Instruments: STIS/CCD, STIS/FUV-MAMA Special Requirements: AFTER 13 BY 75 D TO 105 D; ON HOLD <i>On Hold Comments: Awaiting ToO Trigger.</i>										
	(Visit 16) Warning (Orbit Planner): ORBITAL VISIBILITY OVERRUN (Visit 16) Warning (Orbit Planner): ORBITAL VISIBILITY OVERRUN										
Diagnosics											
Patterns	#	Primary Pattern				Secondary Pattern				Exposures	
	(1)	Pattern Type=STIS-ALONG-SLIT		Coordinate Frame=POS-TARG						(2), (3)	
		Purpose=DITHER		Pattern Orientation=90.0							
		Number Of Points=3		Angle Between Sides=							
		Point Spacing=0.4165		Center Pattern=false							
		Line Spacing=									
Generic Targets	#	Name	Criteria			Description					
	(3)	TDF3	Tidal Disruption Flare			ACCRETION DISK NUCLEUS					
<i>Comments: Nuclear transient not obviously AGN or supernova at z <- 0.3.</i>											
Exposures	#	Label (ETC Run)	Target	Config,Mode,Aperture	Spectral Els.	Opt. Params.	Special Reqs.	Groups	Exp. Time (Total)/[Actual Dur.]		Orbit
	1	(STIS.ta.100 3503)	(3) TDF3	STIS/CCD, ACQ, F28X50LP	MIRROR				100 Secs (100 Secs)		
										[==>]	[1]
	2	(STIS.sp.10 03505)	(3) TDF3	STIS/FUV-MAMA, ACCUM, 52X0.2	G140L 1425 A			Pattern 1, Exps 2-2 in Visit 16 (1)	600. Secs (1800 Secs)		
										[==>(Pattern 1)]	[1]
									[==>(Pattern 2)]		
									[==>(Pattern 3)]		
3	(STIS.sp.10 03505)	(3) TDF3	STIS/FUV-MAMA, ACCUM, 52X0.2	G140L 1425 A			Pattern 1, Exps 3-3 in Visit 16 (1)	885. Secs (2655 Secs)			
									[==>(Pattern 1)]		
									[==>(Pattern 2)]	[2]	
									[==>(Pattern 3)]		

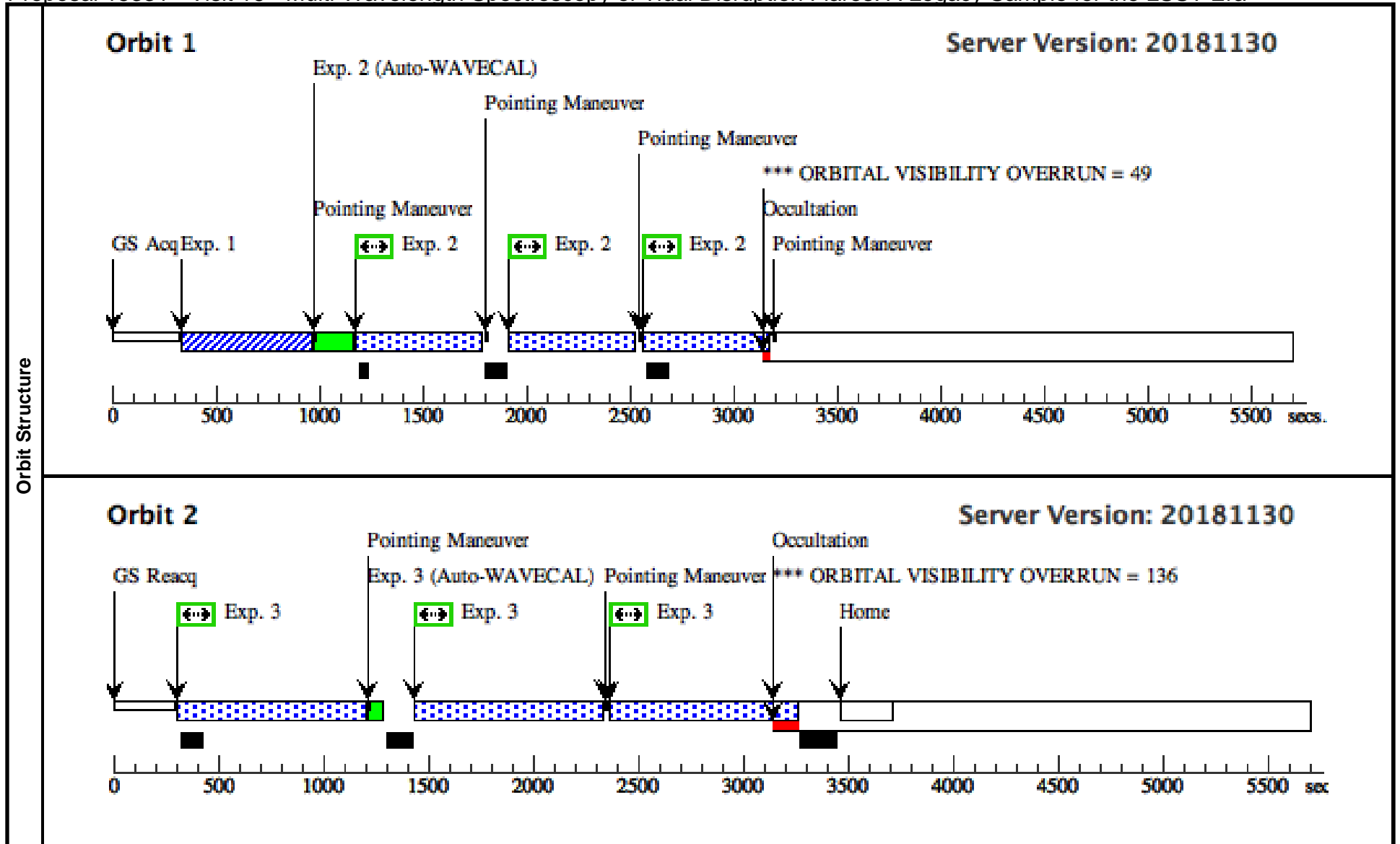

Proposal 15331 - Visit 17 - Multi-Wavelength Spectroscopy of Tidal Disruption Flares: A Legacy Sample for the LSST Era

Fri Jan 25 14:01:47 GMT 2019

Visit	Proposal 15331, Visit 17, completed Diagnostic Status: Warning Scientific Instruments: STIS/NUV-MAMA, STIS/CCD Special Requirements: BETWEEN 01-NOV-2018:00:00:00 AND 31-DEC-2018:00:00:00											
	(Visit 17) Warning (Orbit Planner): ORBITAL VISIBILITY OVERRUN (Visit 17) Warning (Orbit Planner): ORBITAL VISIBILITY OVERRUN											
Diagnosics												
Patterns	#	Primary Pattern				Secondary Pattern				Exposures		
	(1)	Pattern Type=STIS-ALONG-SLIT Purpose=DITHER Number Of Points=3 Point Spacing=0.4165 Line Spacing=		Coordinate Frame=POS-TARG Pattern Orientation=90.0 Angle Between Sides= Center Pattern=false						(2), (3), (4)		
Fixed Targets	#	Name	Target Coordinates		Targ. Coord. Corrections		Fluxes	Miscellaneous				
	(6)	AT2018ZR	RA: 07 56 54.5489 (119.2272871d) Dec: +34 15 43.63 (34.26212d) Equinox: J2000				V=18.0	Reference Frame: ICRS				
Comments: Category=GALAXY Description=[ACCRETION DISK]												
Exposures	#	Label (ETC Run)	Target	Config,Mode,Aperture	Spectral Els.	Opt. Params.	Special Reqs.	Groups	Exp. Time (Total)/[Actual Dur.]		Orbit	
	1	(STIS.ta.100 3507)	(6) AT2018ZR	STIS/CCD, ACQ, 50CCD	MIRROR				60 Secs (60 Secs)			
									[==>]		[1]	
	2	(STIS.sp.10 03509)	(6) AT2018ZR	STIS/NUV-MAMA, ACCUM, 52X0.2	G230L 2376 A				Pattern 1, Exps 2-2 in Visit 17 (1)	630. Secs (1890 Secs)		
										[==>(Pattern 1)]		
									[==>(Pattern 2)]		[1]	
									[==>(Pattern 3)]			
3	(STIS.sp.10 03509)	(6) AT2018ZR	STIS/NUV-MAMA, ACCUM, 52X0.2	G230L 2376 A				Pattern 1, Exps 3-3 in Visit 17 (1)	865. Secs (2595 Secs)			
									[==>(Pattern 1)]			
									[==>(Pattern 2)]		[2]	
									[==>(Pattern 3)]			
4	(STIS.sp.10 03509)	(6) AT2018ZR	STIS/NUV-MAMA, ACCUM, 52X0.2	G230L 2376 A				Pattern 1, Exps 4-4 in Visit 17 (1)	865. Secs (2595 Secs)			
									[==>(Pattern 1)]			
									[==>(Pattern 2)]		[3]	
									[==>(Pattern 3)]			

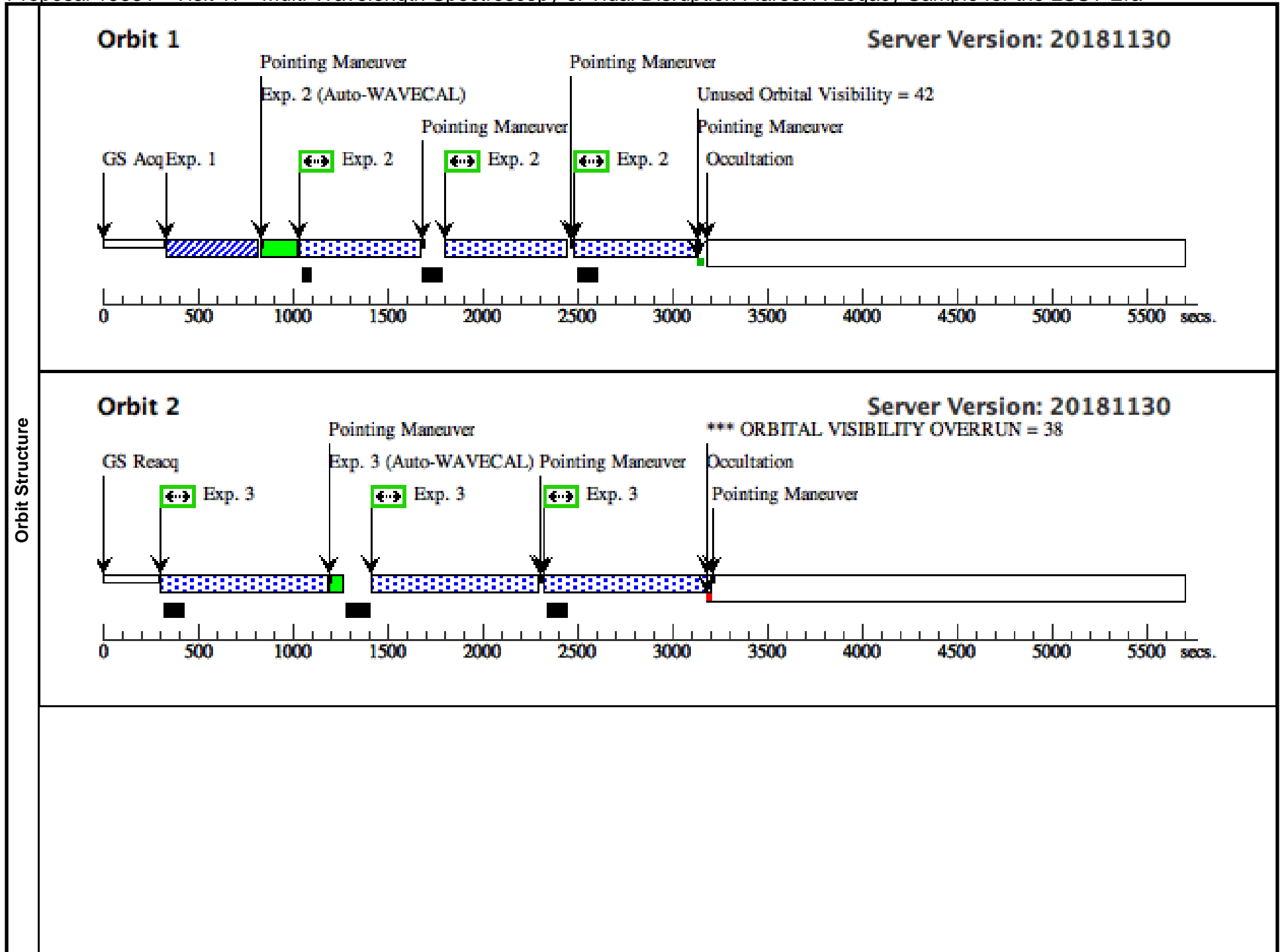

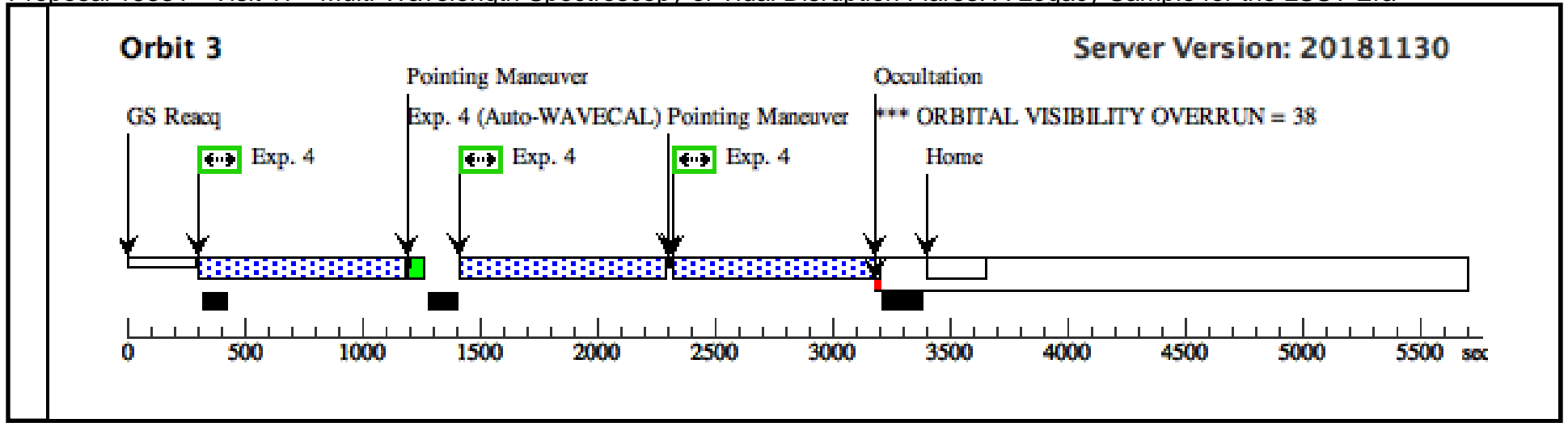

Proposal 15331 - Visit 18 - Multi-Wavelength Spectroscopy of Tidal Disruption Flares: A Legacy Sample for the LSST Era

Fri Jan 25 14:01:47 GMT 2019

Visit	Proposal 15331, Visit 18, completed Diagnostic Status: Warning Scientific Instruments: STIS/CCD, STIS/FUV-MAMA Special Requirements: BETWEEN 01-NOV-2018:00:00:00 AND 31-DEC-2018:00:00:00										
	(Visit 18) Warning (Orbit Planner): ORBITAL VISIBILITY OVERRUN (Visit 18) Warning (Orbit Planner): ORBITAL VISIBILITY OVERRUN										
Diagnosics											
Patterns	#	Primary Pattern				Secondary Pattern				Exposures	
	(1)	Pattern Type=STIS-ALONG-SLIT Purpose=DITHER Number Of Points=3 Point Spacing=0.4165 Line Spacing=		Coordinate Frame=POS-TARG Pattern Orientation=90.0 Angle Between Sides= Center Pattern=false						(2), (3), (4)	
Fixed Targets	#	Name	Target Coordinates		Targ. Coord. Corrections		Fluxes	Miscellaneous			
	(6)	AT2018ZR	RA: 07 56 54.5489 (119.2272871d) Dec: +34 15 43.63 (34.26212d) Equinox: J2000				V=18.0	Reference Frame: ICRS			
Comments: Category=GALAXY Description=[ACCRETION DISK]											
Exposures	#	Label (ETC Run)	Target	Config,Mode,Aperture	Spectral Els.	Opt. Params.	Special Reqs.	Groups	Exp. Time (Total)/[Actual Dur.]		Orbit
	1	(STIS.ta.100 3507)	(6) AT2018ZR	STIS/CCD, ACQ, 50CCD	MIRROR				60 Secs (60 Secs)		
									[==>]		[1]
	2	(STIS.sp.10 03510)	(6) AT2018ZR	STIS/FUV-MAMA, ACCUM, 52X0.2	G140L 1425 A			Pattern 1, Exps 2-2 in Visit 18 (1)	630. Secs (1890 Secs)		
									[==>(Pattern 1)]		
								[==>(Pattern 2)]		[1]	
								[==>(Pattern 3)]			
3	(STIS.sp.10 03510)	(6) AT2018ZR	STIS/FUV-MAMA, ACCUM, 52X0.2	G140L 1425 A			Pattern 1, Exps 3-3 in Visit 18 (1)	865. Secs (2595 Secs)			
								[==>(Pattern 1)]			
								[==>(Pattern 2)]		[2]	
								[==>(Pattern 3)]			
4	(STIS.sp.10 03510)	(6) AT2018ZR	STIS/FUV-MAMA, ACCUM, 52X0.2	G140L 1425 A			Pattern 1, Exps 4-4 in Visit 18 (1)	865. Secs (2595 Secs)			
								[==>(Pattern 1)]			
								[==>(Pattern 2)]		[3]	
								[==>(Pattern 3)]			

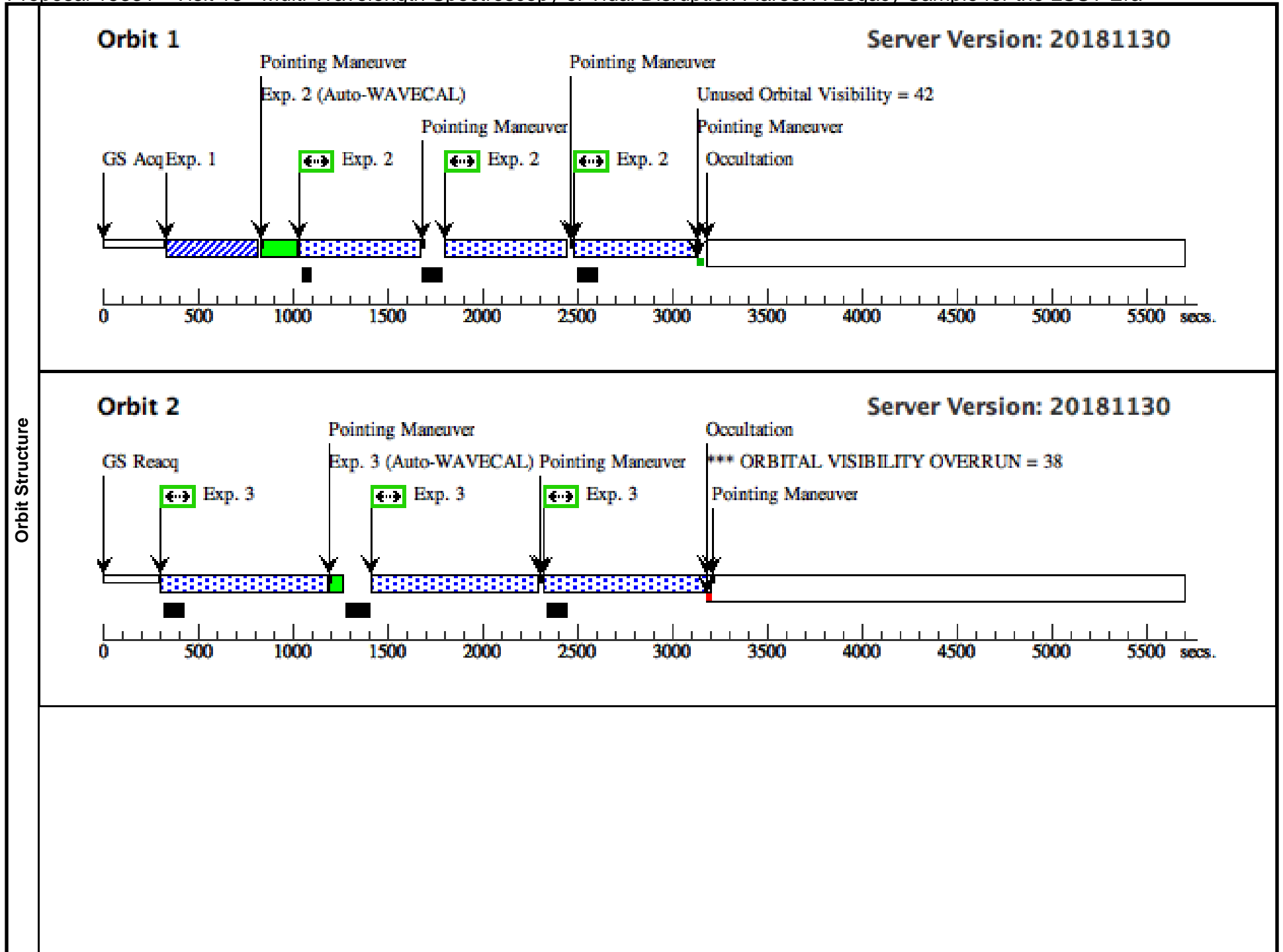

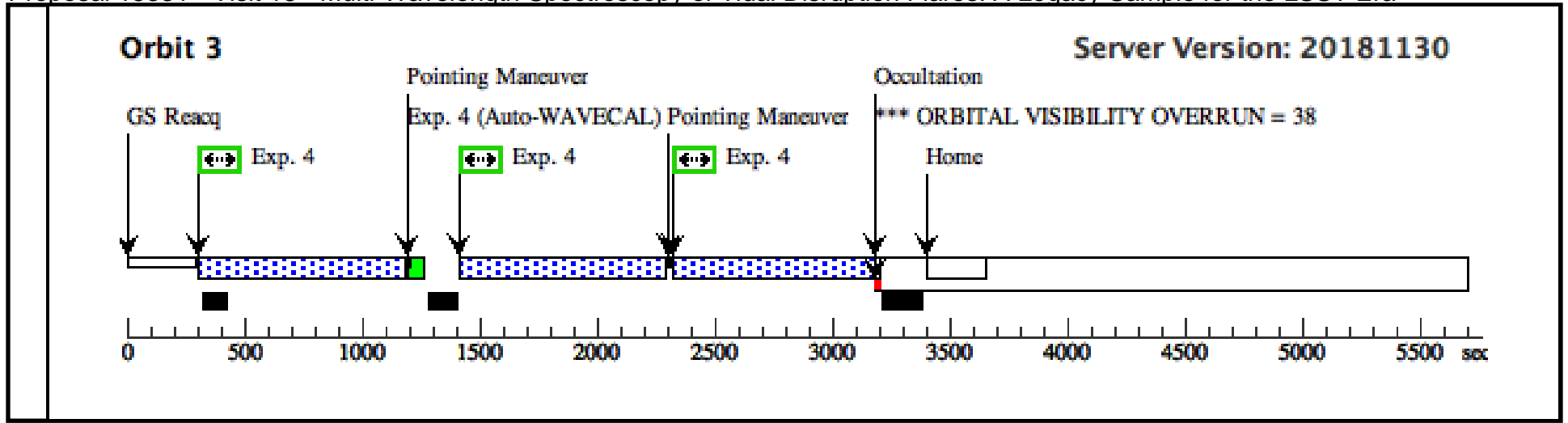

Proposal 15331 - Visit 19 - Multi-Wavelength Spectroscopy of Tidal Disruption Flares: A Legacy Sample for the LSST Era

Fri Jan 25 14:01:47 GMT 2019

Visit	Proposal 15331, Visit 19, withdrawn Diagnostic Status: Warning Scientific Instruments: STIS/NUV-MAMA, STIS/CCD, STIS/FUV-MAMA Special Requirements: ON HOLD ; TOO RESPONSE TIME 21.0D <i>On Hold Comments: Awaiting ToO trigger</i>									
	(Visit 19) Warning (Orbit Planner): ORBITAL VISIBILITY OVERRUN (Visit 19) Warning (Orbit Planner): ORBITAL VISIBILITY OVERRUN									
Diagnosics										
Patterns	#	Primary Pattern				Secondary Pattern				Exposures
	(1)	Pattern Type=STIS-ALONG-SLIT		Coordinate Frame=POS-TARG						(2), (3)
		Purpose=DITHER		Pattern Orientation=90.0						
		Number Of Points=3		Angle Between Sides=						
		Point Spacing=0.4165		Center Pattern=false						
		Line Spacing=								
Generic Targets	#	Name	Criteria	Description						
	(4)	TDF4	Tidal Disruption Flare	ACCRETION DISK NUCLEUS						
									<i>Comments: Nuclear transient not obviously AGN or supernova at z <~ 0.3.</i>	
Exposures	#	Label (ETC Run)	Target	Config,Mode,Aperture	Spectral Els.	Opt. Params.	Special Reqs.	Groups	Exp. Time (Total)/[Actual Dur.]	Orbit
	1	(STIS.ta.100 3498)	(4) TDF4	STIS/CCD, ACQ, F28X50LP	MIRROR				45 Secs (45 Secs)	
										[==>]
										[1]
	2	(STIS.sp.10 03499)	(4) TDF4	STIS/NUV-MAMA, ACCUM, 52X0.2	G230L 2376 A			Pattern 1, Exps 2-2 in Visit 19 (1)	674. Secs (2022 Secs)	
									[==>(Pattern 1)]	
									[==>(Pattern 2)]	
									[==>(Pattern 3)]	
3	(STIS.sp.10 03500)	(4) TDF4	STIS/FUV-MAMA, ACCUM, 52X0.2	G140L 1425 A			Pattern 1, Exps 3-3 in Visit 19 (1)	920. Secs (2760 Secs)		
									[==>(Pattern 1)]	
									[==>(Pattern 2)]	
									[==>(Pattern 3)]	
									[2]	

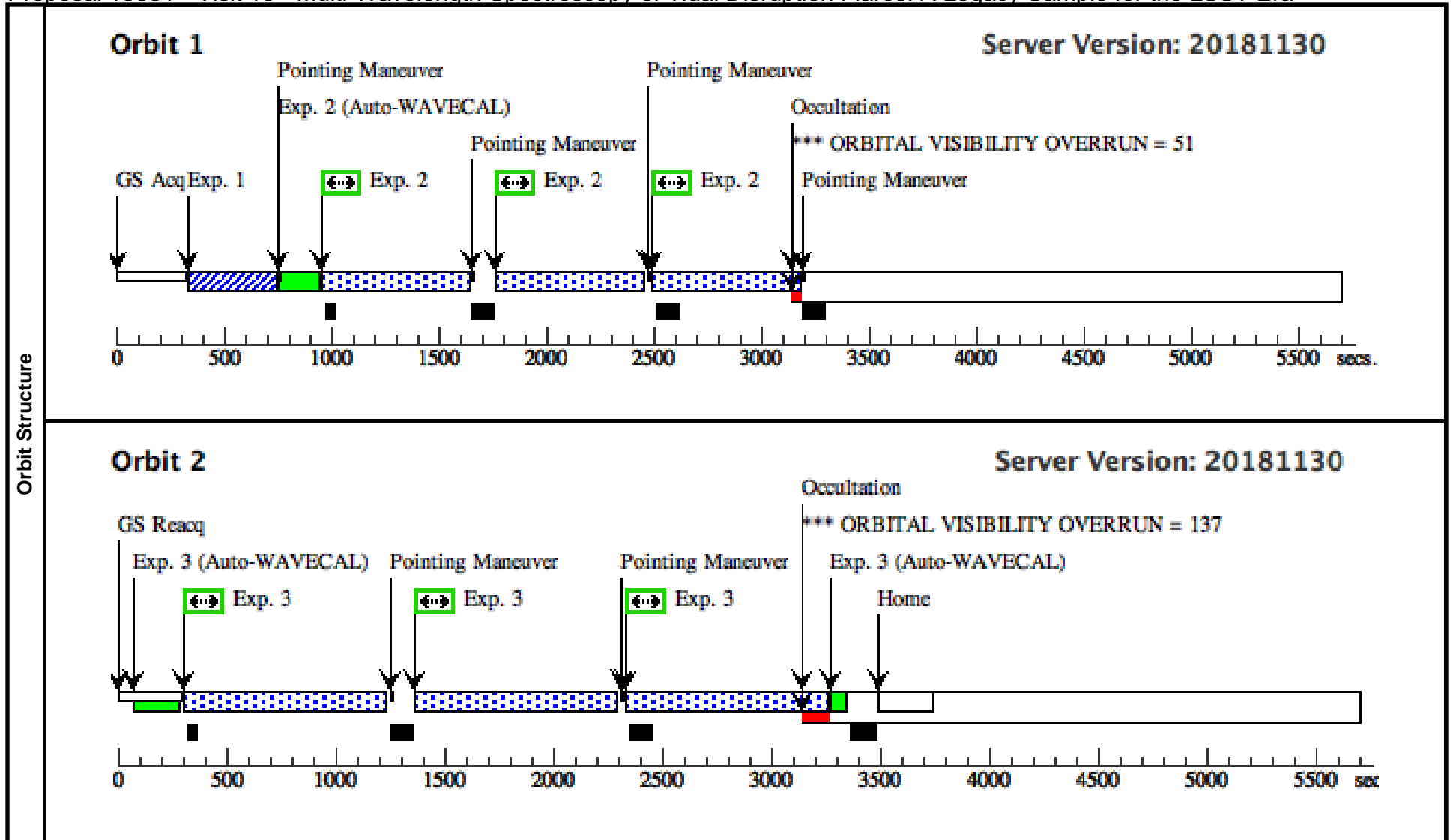

Proposal 15331 - Visit 20 - Multi-Wavelength Spectroscopy of Tidal Disruption Flares: A Legacy Sample for the LSST Era

Fri Jan 25 14:01:47 GMT 2019

Visit	Proposal 15331, Visit 20, withdrawn Diagnostic Status: Warning Scientific Instruments: STIS/NUV-MAMA, STIS/CCD, STIS/FUV-MAMA Special Requirements: AFTER 19 BY 20 D TO 40 D; ON HOLD <i>On Hold Comments: Awaiting ToO Trigger.</i>									
	(Visit 20) Warning (Orbit Planner): ORBITAL VISIBILITY OVERRUN (Visit 20) Warning (Orbit Planner): ORBITAL VISIBILITY OVERRUN									
Diagnosics										
Patterns	#	Primary Pattern				Secondary Pattern				Exposures
	(1)	Pattern Type=STIS-ALONG-SLIT		Coordinate Frame=POS-TARG						(2), (3)
		Purpose=DITHER		Pattern Orientation=90.0						
		Number Of Points=3		Angle Between Sides=						
		Point Spacing=0.4165		Center Pattern=false						
		Line Spacing=								
Generic Targets	#	Name	Criteria	Description						
	(4)	TDF4	Tidal Disruption Flare	ACCRETION DISK NUCLEUS						
									<i>Comments: Nuclear transient not obviously AGN or supernova at z <~ 0.3.</i>	
Exposures	#	Label (ETC Run)	Target	Config,Mode,Aperture	Spectral Els.	Opt. Params.	Special Reqs.	Groups	Exp. Time (Total)/[Actual Dur.]	Orbit
	1	(STIS.ta.100 3498)	(4) TDF4	STIS/CCD, ACQ, F28X50LP	MIRROR				45 Secs (45 Secs)	
										[=>]
	2	(STIS.sp.10 03499)	(4) TDF4	STIS/NUV-MAMA, ACCUM, 52X0.2	G230L 2376 A			Pattern 1, Exps 2-2 in Visit 20 (1)	674. Secs (2022 Secs)	
										[=>(Pattern 1)]
									[=>(Pattern 2)]	
									[=>(Pattern 3)]	
3	(STIS.sp.10 03500)	(4) TDF4	STIS/FUV-MAMA, ACCUM, 52X0.2	G140L 1425 A			Pattern 1, Exps 3-3 in Visit 20 (1)	920. Secs (2760 Secs)		
									[=>(Pattern 1)]	
									[=>(Pattern 2)]	
									[=>(Pattern 3)]	
									[2]	

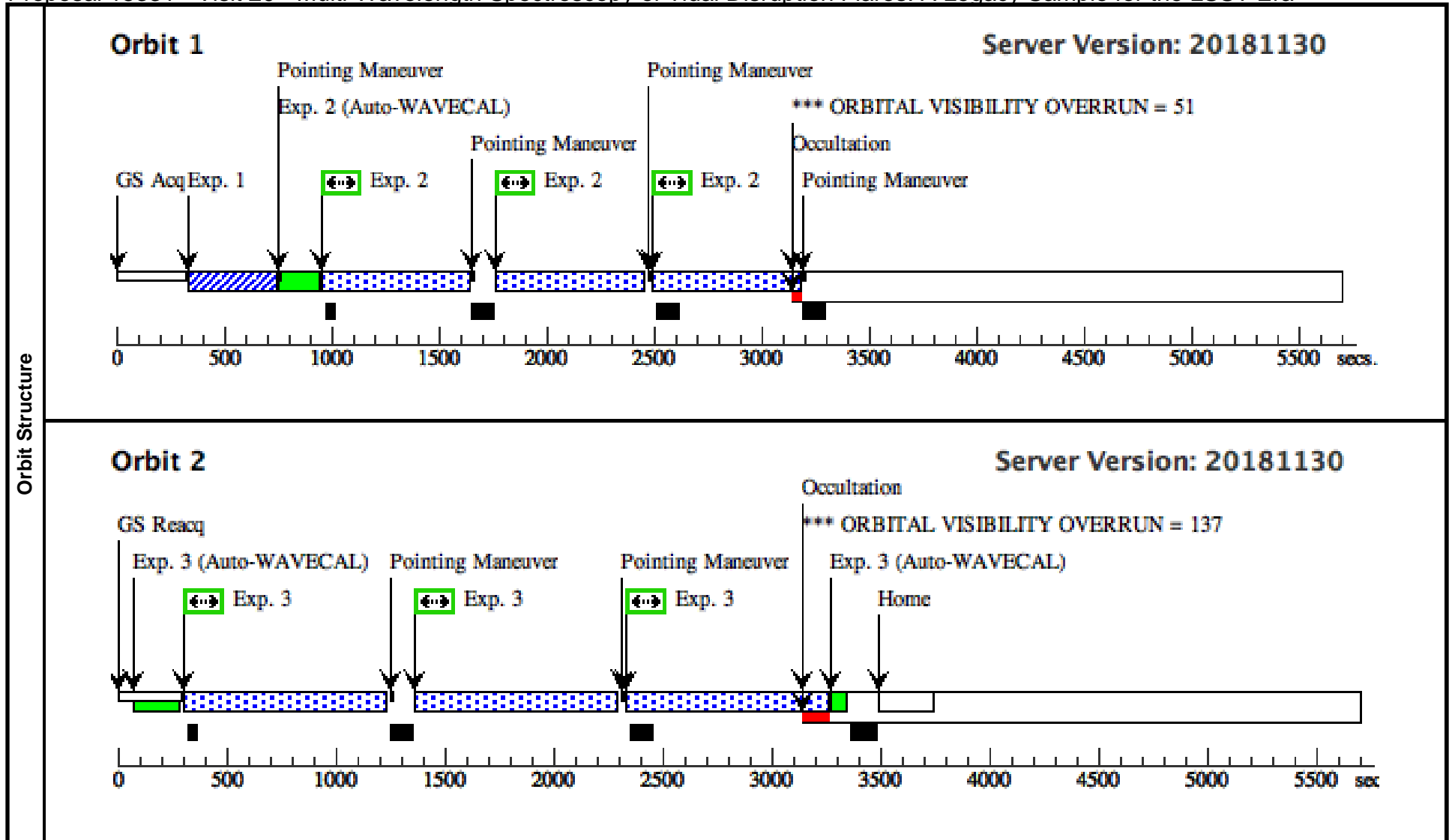

Proposal 15331 - Visit 21 - Multi-Wavelength Spectroscopy of Tidal Disruption Flares: A Legacy Sample for the LSST Era

Fri Jan 25 14:01:47 GMT 2019

Visit	Proposal 15331, Visit 21, withdrawn Diagnostic Status: Warning Scientific Instruments: STIS/NUV-MAMA, STIS/CCD Special Requirements: AFTER 19 BY 75 D TO 105 D; ON HOLD <i>On Hold Comments: Awaiting ToO Trigger.</i>										
	(Visit 21) Warning (Orbit Planner): ORBITAL VISIBILITY OVERRUN (Visit 21) Warning (Orbit Planner): ORBITAL VISIBILITY OVERRUN										
Diagnosics											
Patterns	#	Primary Pattern				Secondary Pattern				Exposures	
	(1)	Pattern Type=STIS-ALONG-SLIT		Coordinate Frame=POS-TARG						(2), (3)	
		Purpose=DITHER		Pattern Orientation=90.0							
		Number Of Points=3		Angle Between Sides=							
		Point Spacing=0.4165		Center Pattern=false							
		Line Spacing=									
Generic Targets	#	Name	Criteria			Description					
	(4)	TDF4	Tidal Disruption Flare			ACCRETION DISK NUCLEUS					
<i>Comments: Nuclear transient not obviously AGN or supernova at z <- 0.3.</i>											
Exposures	#	Label (ETC Run)	Target	Config,Mode,Aperture	Spectral Els.	Opt. Params.	Special Reqs.	Groups	Exp. Time (Total)/[Actual Dur.]		Orbit
	1	(STIS.ta.100 3503)	(4) TDF4	STIS/CCD, ACQ, F28X50LP	MIRROR				100 Secs (100 Secs)		
										[==>]	[1]
	2	(STIS.sp.10 03504)	(4) TDF4	STIS/NUV-MAMA, ACCUM, 52X0.2	G230L 2376 A			Pattern 1, Exps 2-2 in Visit 21 (1)	600. Secs (1800 Secs)		
										[==>(Pattern 1)]	[1]
									[==>(Pattern 2)]		
									[==>(Pattern 3)]		
3	(STIS.sp.10 03504)	(4) TDF4	STIS/NUV-MAMA, ACCUM, 52X0.2	G230L 2376 A			Pattern 1, Exps 3-3 in Visit 21 (1)	885. Secs (2655 Secs)			
									[==>(Pattern 1)]		
									[==>(Pattern 2)]	[2]	
									[==>(Pattern 3)]		

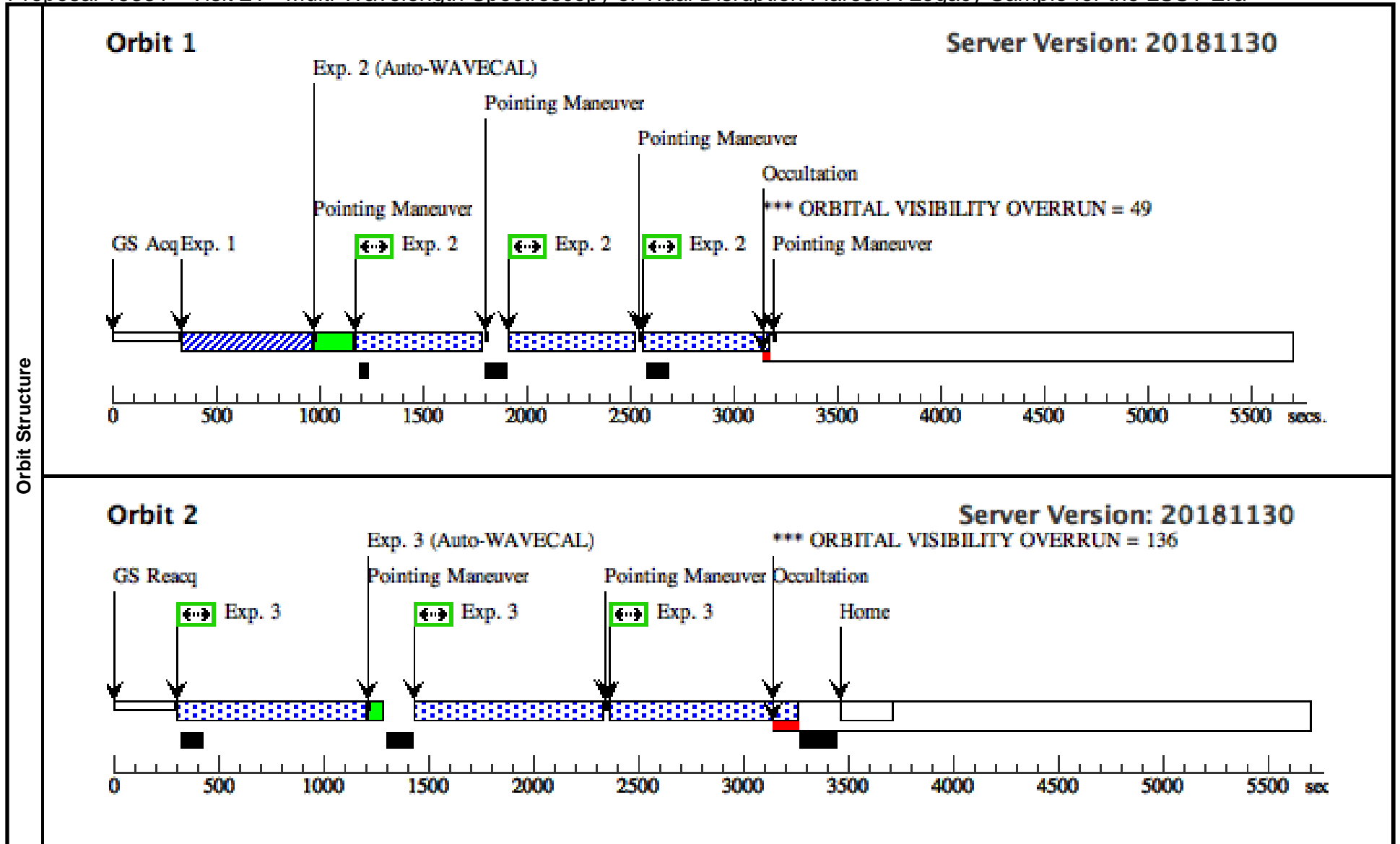

Proposal 15331 - Visit 22 - Multi-Wavelength Spectroscopy of Tidal Disruption Flares: A Legacy Sample for the LSST Era

Fri Jan 25 14:01:47 GMT 2019

Visit	Proposal 15331, Visit 22, withdrawn Diagnostic Status: Warning Scientific Instruments: STIS/CCD, STIS/FUV-MAMA Special Requirements: AFTER 19 BY 75 D TO 105 D; ON HOLD <i>On Hold Comments: Awaiting ToO Trigger.</i>										
	(Visit 22) Warning (Orbit Planner): ORBITAL VISIBILITY OVERRUN (Visit 22) Warning (Orbit Planner): ORBITAL VISIBILITY OVERRUN										
Diagnosics											
Patterns	#	Primary Pattern				Secondary Pattern				Exposures	
	(1)	Pattern Type=STIS-ALONG-SLIT		Coordinate Frame=POS-TARG						(2), (3)	
		Purpose=DITHER		Pattern Orientation=90.0							
		Number Of Points=3		Angle Between Sides=							
		Point Spacing=0.4165		Center Pattern=false							
		Line Spacing=									
Generic Targets	#	Name	Criteria			Description					
	(4)	TDF4	Tidal Disruption Flare			ACCRETION DISK NUCLEUS					
<i>Comments: Nuclear transient not obviously AGN or supernova at z <~ 0.3.</i>											
Exposures	#	Label (ETC Run)	Target	Config,Mode,Aperture	Spectral Els.	Opt. Params.	Special Reqs.	Groups	Exp. Time (Total)/[Actual Dur.]		Orbit
	1	(STIS.ta.100 3503)	(4) TDF4	STIS/CCD, ACQ, F28X50LP	MIRROR				100 Secs (100 Secs)		
										[==>]	[1]
	2	(STIS.sp.10 03505)	(4) TDF4	STIS/FUV-MAMA, ACCUM, 52X0.2	G140L 1425 A			Pattern 1, Exps 2-2 in Visit 22 (1)	600. Secs (1800 Secs)		
										[==>(Pattern 1)]	
									[==>(Pattern 2)]	[1]	
									[==>(Pattern 3)]		
3	(STIS.sp.10 03505)	(4) TDF4	STIS/FUV-MAMA, ACCUM, 52X0.2	G140L 1425 A			Pattern 1, Exps 3-3 in Visit 22 (1)	885. Secs (2655 Secs)			
									[==>(Pattern 1)]		
									[==>(Pattern 2)]	[2]	
									[==>(Pattern 3)]		

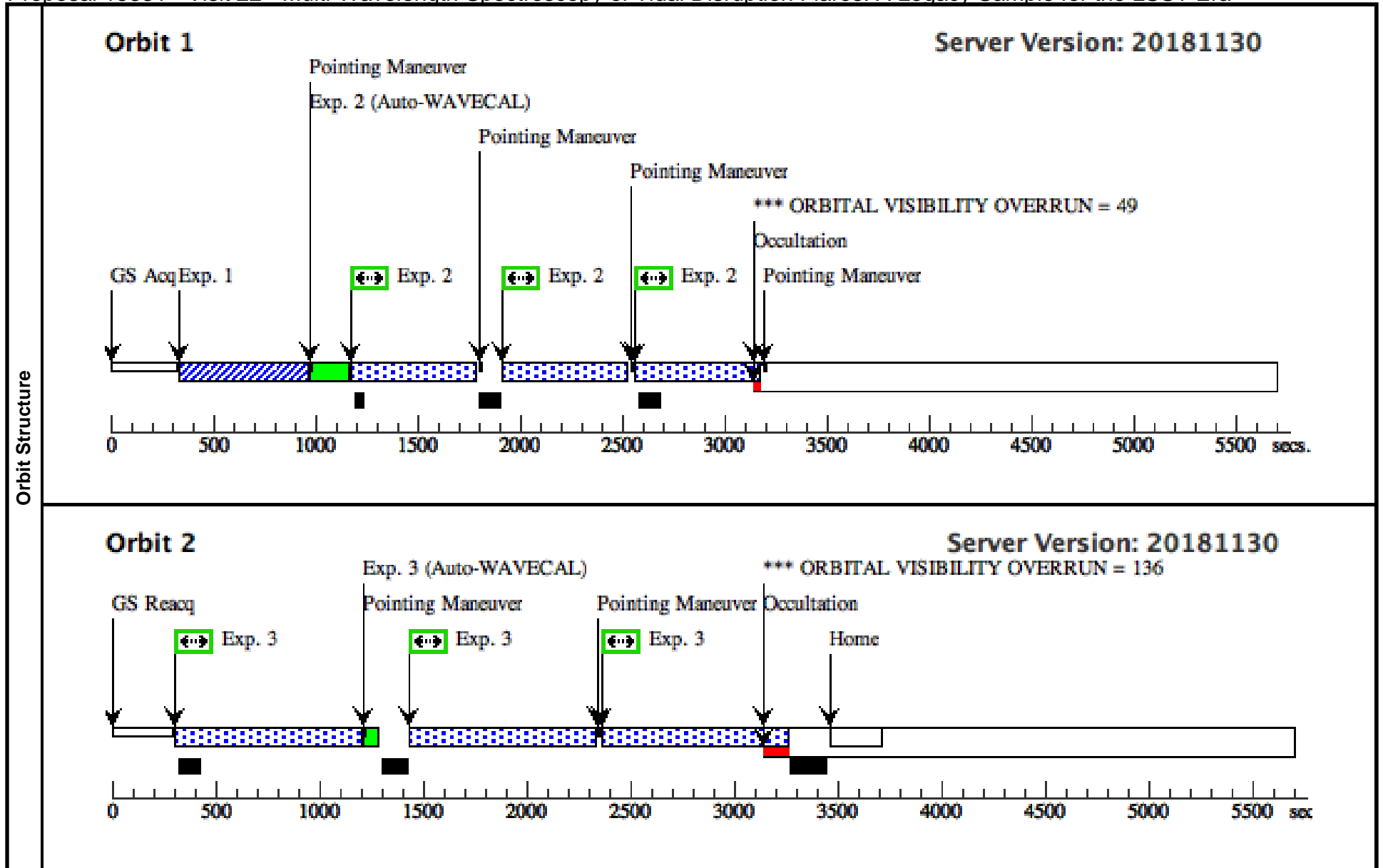

Proposal 15331 - Visit 23 - Multi-Wavelength Spectroscopy of Tidal Disruption Flares: A Legacy Sample for the LSST Era

Fri Jan 25 14:01:47 GMT 2019

Visit	Proposal 15331, Visit 23, withdrawn Diagnostic Status: Warning Scientific Instruments: STIS/NUV-MAMA, STIS/CCD Special Requirements: AFTER 19 BY 150 D TO 210 D; ON HOLD <i>On Hold Comments: Awaiting ToO Trigger.</i>										
	(Visit 23) Warning (Orbit Planner): ORBITAL VISIBILITY OVERRUN (Visit 23) Warning (Orbit Planner): ORBITAL VISIBILITY OVERRUN (Visit 23) Warning (Orbit Planner): ORBITAL VISIBILITY OVERRUN										
Diagnosics											
Patterns	#	Primary Pattern				Secondary Pattern				Exposures	
	(1)	Pattern Type=STIS-ALONG-SLIT		Coordinate Frame=POS-TARG						(2), (3), (4)	
		Purpose=DITHER		Pattern Orientation=90.0							
		Number Of Points=3		Angle Between Sides=							
		Point Spacing=0.4165		Center Pattern=false							
		Line Spacing=									
Generic Targets	#	Name	Criteria			Description					
	(4)	TDF4	Tidal Disruption Flare			ACCRETION DISK NUCLEUS					
<i>Comments: Nuclear transient not obviously AGN or supernova at z <~ 0.3.</i>											
Exposures	#	Label (ETC Run)	Target	Config,Mode,Aperture	Spectral Els.	Opt. Params.	Special Reqs.	Groups	Exp. Time (Total)/[Actual Dur.]		Orbit
	1	(STIS.ta.100 3507)	(4) TDF4	STIS/CCD, ACQ, 50CCD	MIRROR				60 Secs (60 Secs)		
									[==>]		[1]
	2	(STIS.sp.10 03509)	(4) TDF4	STIS/NUV-MAMA, ACCUM, 52X0.2	G230L 2376 A			Pattern 1, Exps 2-2 in Visit 23 (1)	650. Secs (1950 Secs)		
									[==>(Pattern 1)]		[1]
								[==>(Pattern 2)]			
								[==>(Pattern 3)]			
3	(STIS.sp.10 03509)	(4) TDF4	STIS/NUV-MAMA, ACCUM, 52X0.2	G230L 2376 A			Pattern 1, Exps 3-3 in Visit 23 (1)	885. Secs (2655 Secs)			
								[==>(Pattern 1)]		[2]	
								[==>(Pattern 2)]			
								[==>(Pattern 3)]			
4	(STIS.sp.10 03509)	(4) TDF4	STIS/NUV-MAMA, ACCUM, 52X0.2	G230L 2376 A			Pattern 1, Exps 4-4 in Visit 23 (1)	885. Secs (2655 Secs)			
								[==>(Pattern 1)]		[3]	
								[==>(Pattern 2)]			
								[==>(Pattern 3)]			

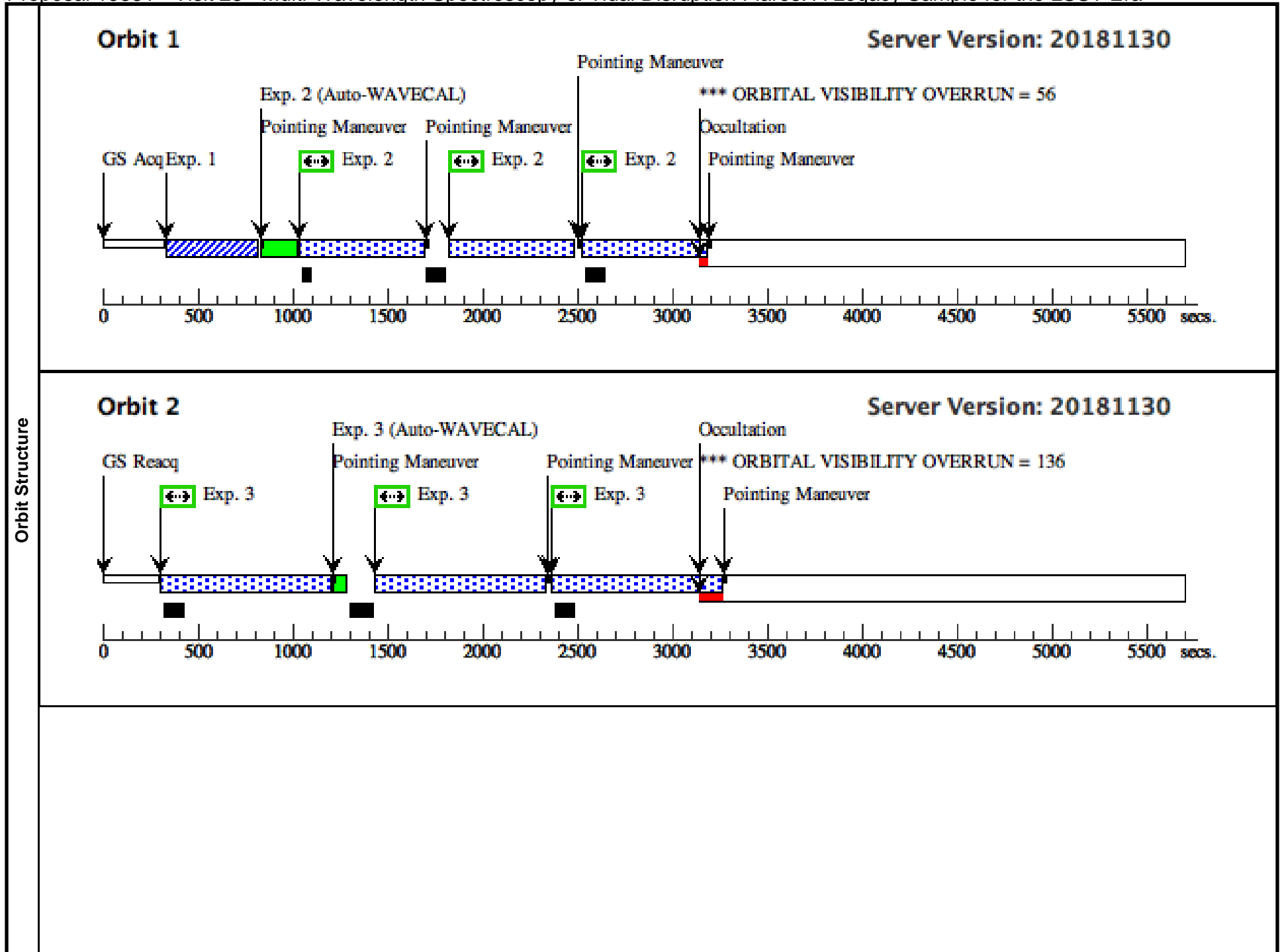

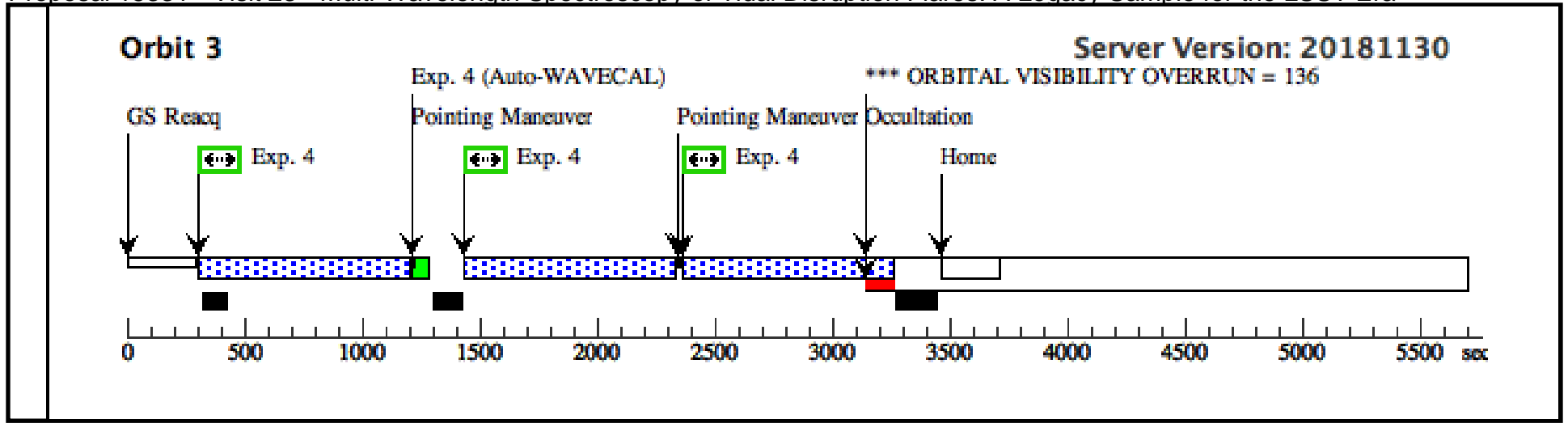

Proposal 15331 - Visit 24 - Multi-Wavelength Spectroscopy of Tidal Disruption Flares: A Legacy Sample for the LSST Era

Fri Jan 25 14:01:47 GMT 2019

Visit	Proposal 15331, Visit 24, withdrawn Diagnostic Status: Warning Scientific Instruments: STIS/CCD, STIS/FUV-MAMA Special Requirements: AFTER 19 BY 150 D TO 210 D; ON HOLD <i>On Hold Comments: Awaiting ToO Trigger.</i>										
	(Visit 24) Warning (Orbit Planner): ORBITAL VISIBILITY OVERRUN (Visit 24) Warning (Orbit Planner): ORBITAL VISIBILITY OVERRUN (Visit 24) Warning (Orbit Planner): ORBITAL VISIBILITY OVERRUN										
Diagnosics											
Patterns	#	Primary Pattern				Secondary Pattern				Exposures	
	(1)	Pattern Type=STIS-ALONG-SLIT		Coordinate Frame=POS-TARG						(2), (3), (4)	
		Purpose=DITHER		Pattern Orientation=90.0							
		Number Of Points=3		Angle Between Sides=							
		Point Spacing=0.4165		Center Pattern=false							
		Line Spacing=									
Generic Targets	#	Name	Criteria			Description					
	(4)	TDF4	Tidal Disruption Flare			ACCRETION DISK NUCLEUS					
<i>Comments: Nuclear transient not obviously AGN or supernova at z <- 0.3.</i>											
Exposures	#	Label (ETC Run)	Target	Config,Mode,Aperture	Spectral Els.	Opt. Params.	Special Reqs.	Groups	Exp. Time (Total)/[Actual Dur.]		Orbit
	1	(STIS.ta.100 3507)	(4) TDF4	STIS/CCD, ACQ, 50CCD	MIRROR				60 Secs (60 Secs)		
										[==>]	[1]
	2	(STIS.sp.10 03510)	(4) TDF4	STIS/FUV-MAMA, ACCUM, 52X0.2	G140L 1425 A			Pattern 1, Exps 2-2 in Visit 24 (1)	650. Secs (1950 Secs)		
										[==>(Pattern 1)]	[1]
									[==>(Pattern 2)]		
									[==>(Pattern 3)]		
3	(STIS.sp.10 03510)	(4) TDF4	STIS/FUV-MAMA, ACCUM, 52X0.2	G140L 1425 A			Pattern 1, Exps 3-3 in Visit 24 (1)	885. Secs (2655 Secs)			
									[==>(Pattern 1)]	[2]	
									[==>(Pattern 2)]		
									[==>(Pattern 3)]		
4	(STIS.sp.10 03510)	(4) TDF4	STIS/FUV-MAMA, ACCUM, 52X0.2	G140L 1425 A			Pattern 1, Exps 4-4 in Visit 24 (1)	885. Secs (2655 Secs)			
									[==>(Pattern 1)]	[3]	
									[==>(Pattern 2)]		
									[==>(Pattern 3)]		

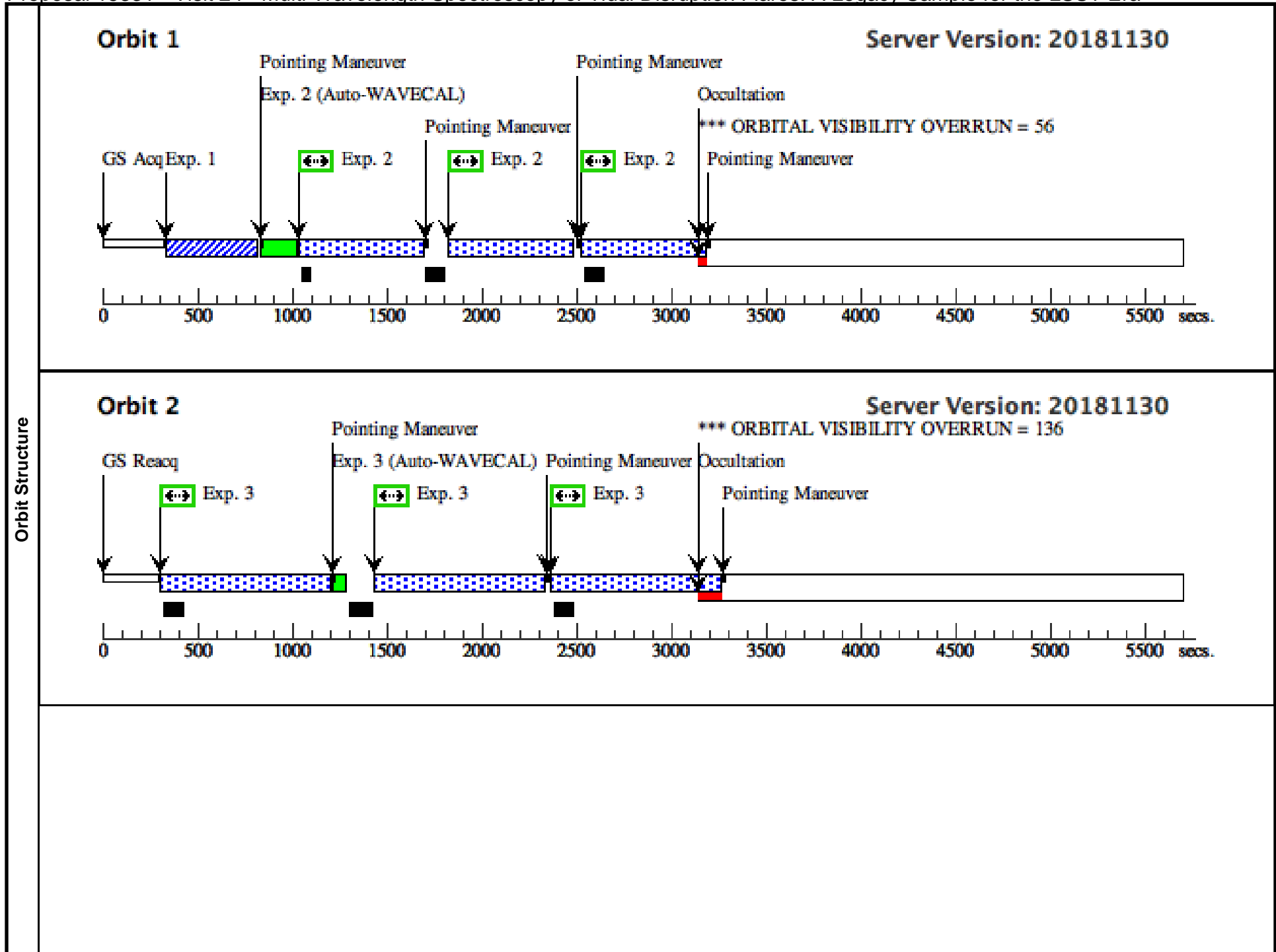

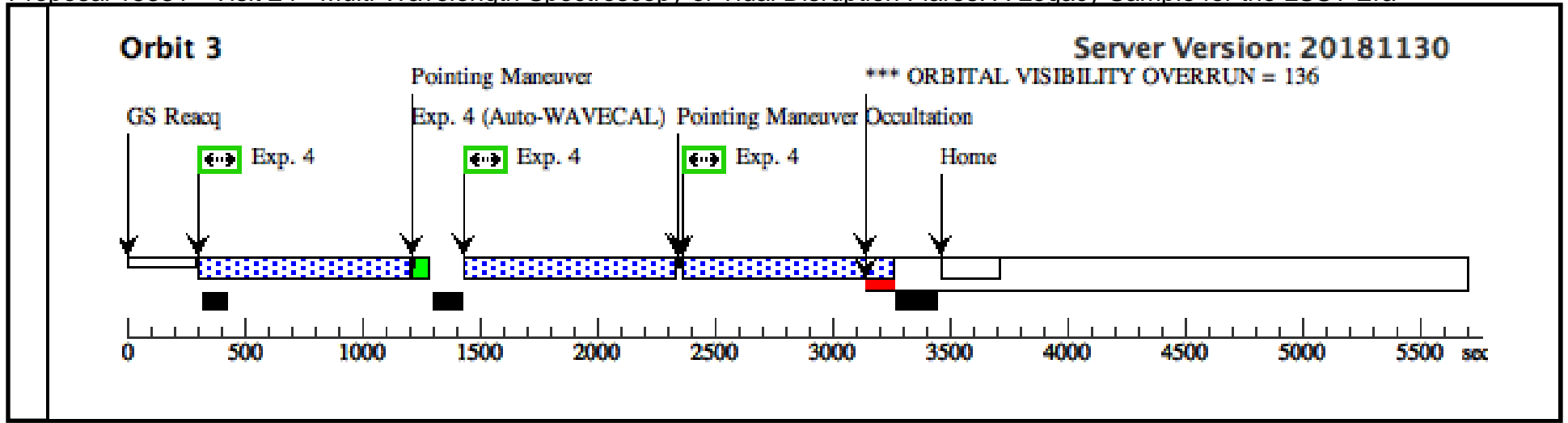

Proposal 15331 - Visit 25 - Multi-Wavelength Spectroscopy of Tidal Disruption Flares: A Legacy Sample for the LSST Era

Fri Jan 25 14:01:47 GMT 2019

Visit	Proposal 15331, Visit 25, withdrawn Diagnostic Status: Warning Scientific Instruments: STIS/NUV-MAMA, STIS/CCD, STIS/FUV-MAMA Special Requirements: ON HOLD ; TOO RESPONSE TIME 21.0D <i>On Hold Comments: Awaiting ToO trigger</i>									
	(Visit 25) Warning (Orbit Planner): ORBITAL VISIBILITY OVERRUN (Visit 25) Warning (Orbit Planner): ORBITAL VISIBILITY OVERRUN									
Diagnosics										
Patterns	#	Primary Pattern				Secondary Pattern				Exposures
	(1)	Pattern Type=STIS-ALONG-SLIT		Coordinate Frame=POS-TARG						(2), (3)
		Purpose=DITHER		Pattern Orientation=90.0						
		Number Of Points=3		Angle Between Sides=						
		Point Spacing=0.4165		Center Pattern=false						
		Line Spacing=								
Generic Targets	#	Name	Criteria	Description						
	(5)	TDF5	Tidal Disruption Flare	ACCRETION DISK NUCLEUS						
									<i>Comments: Nuclear transient not obviously AGN or supernova at z <~ 0.3.</i>	
Exposures	#	Label (ETC Run)	Target	Config,Mode,Aperture	Spectral Els.	Opt. Params.	Special Reqs.	Groups	Exp. Time (Total)/[Actual Dur.]	Orbit
	1	(STIS.ta.100 3498)	(5) TDF5	STIS/CCD, ACQ, F28X50LP	MIRROR				45 Secs (45 Secs)	
										[==>]
										[1]
	2	(STIS.sp.10 03499)	(5) TDF5	STIS/NUV-MAMA, ACCUM, 52X0.2	G230L 2376 A			Pattern 1, Exps 2-2 in Visit 25 (1)	674. Secs (2022 Secs)	
									[==>(Pattern 1)]	
									[==>(Pattern 2)]	
									[==>(Pattern 3)]	
3	(STIS.sp.10 03500)	(5) TDF5	STIS/FUV-MAMA, ACCUM, 52X0.2	G140L 1425 A			Pattern 1, Exps 3-3 in Visit 25 (1)	920. Secs (2760 Secs)		
									[==>(Pattern 1)]	
									[==>(Pattern 2)]	
									[==>(Pattern 3)]	
									[2]	

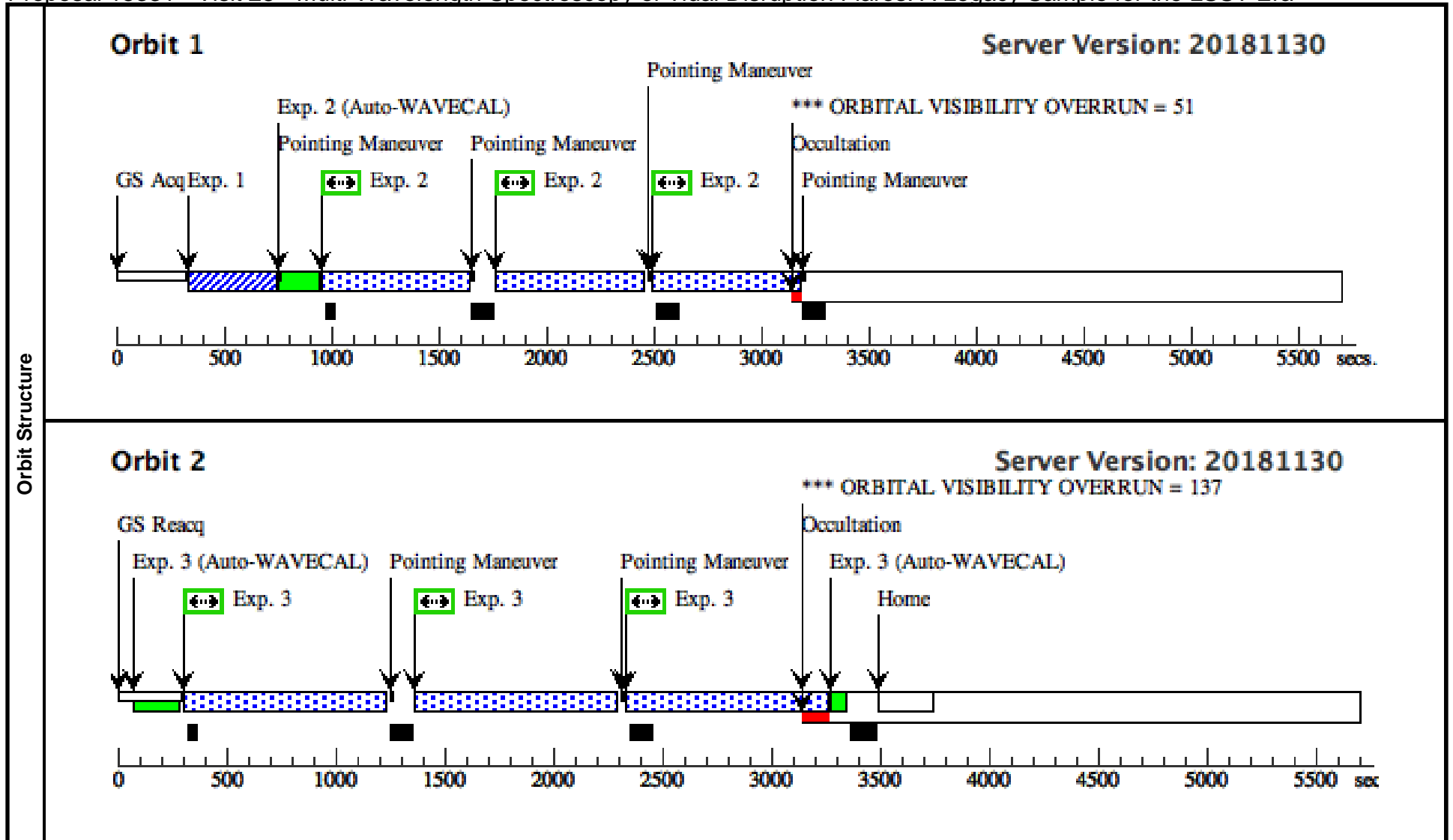

Proposal 15331 - Visit 26 - Multi-Wavelength Spectroscopy of Tidal Disruption Flares: A Legacy Sample for the LSST Era

Fri Jan 25 14:01:47 GMT 2019

Visit	Proposal 15331, Visit 26, withdrawn Diagnostic Status: Warning Scientific Instruments: STIS/NUV-MAMA, STIS/CCD, STIS/FUV-MAMA Special Requirements: AFTER 25 BY 20 D TO 40 D; ON HOLD <i>On Hold Comments: Awaiting ToO Trigger.</i>									
	(Visit 26) Warning (Orbit Planner): ORBITAL VISIBILITY OVERRUN (Visit 26) Warning (Orbit Planner): ORBITAL VISIBILITY OVERRUN									
Diagnosics										
Patterns	#	Primary Pattern				Secondary Pattern				Exposures
	(1)	Pattern Type=STIS-ALONG-SLIT		Coordinate Frame=POS-TARG						(2), (3)
		Purpose=DITHER		Pattern Orientation=90.0						
		Number Of Points=3		Angle Between Sides=						
		Point Spacing=0.4165		Center Pattern=false						
		Line Spacing=								
Generic Targets	#	Name	Criteria	Description						
	(5)	TDF5	Tidal Disruption Flare	ACCRETION DISK NUCLEUS						
									<i>Comments: Nuclear transient not obviously AGN or supernova at z <- 0.3.</i>	
Exposures	#	Label (ETC Run)	Target	Config,Mode,Aperture	Spectral Els.	Opt. Params.	Special Reqs.	Groups	Exp. Time (Total)/[Actual Dur.]	Orbit
	1	(STIS.ta.100 3498)	(5) TDF5	STIS/CCD, ACQ, F28X50LP	MIRROR				45 Secs (45 Secs)	
										[==>]
										[1]
	2	(STIS.sp.10 03499)	(5) TDF5	STIS/NUV-MAMA, ACCUM, 52X0.2	G230L 2376 A			Pattern 1, Exps 2-2 in Visit 26 (1)	674. Secs (2022 Secs)	
									[==>(Pattern 1)]	
									[==>(Pattern 2)]	
									[==>(Pattern 3)]	
									[1]	
3	(STIS.sp.10 03500)	(5) TDF5	STIS/FUV-MAMA, ACCUM, 52X0.2	G140L 1425 A			Pattern 1, Exps 3-3 in Visit 26 (1)	920. Secs (2760 Secs)		
									[==>(Pattern 1)]	
									[==>(Pattern 2)]	
									[==>(Pattern 3)]	
									[2]	

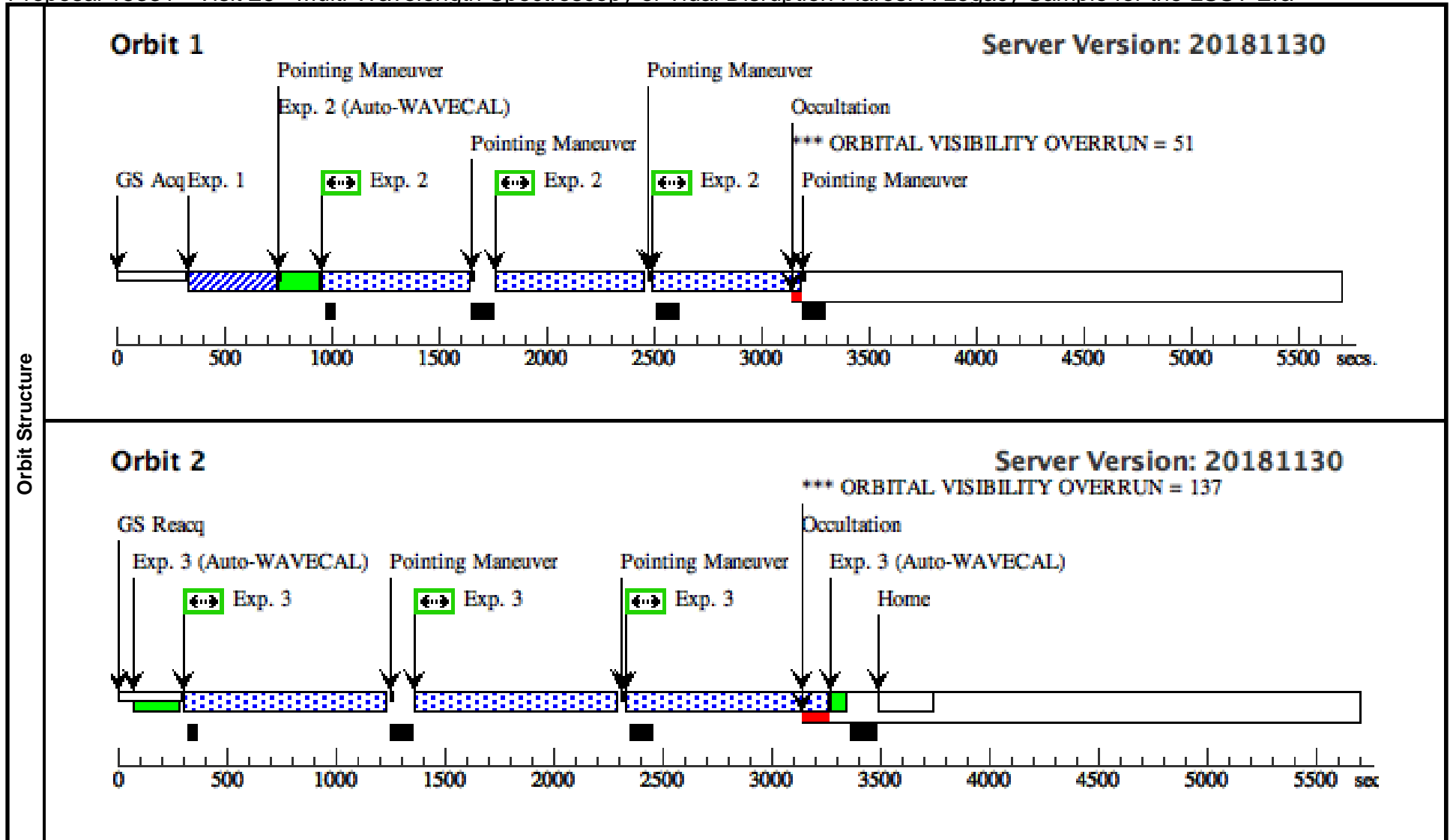

Proposal 15331 - Visit 27 - Multi-Wavelength Spectroscopy of Tidal Disruption Flares: A Legacy Sample for the LSST Era

Fri Jan 25 14:01:47 GMT 2019

Visit	Proposal 15331, Visit 27, withdrawn Diagnostic Status: Warning Scientific Instruments: STIS/NUV-MAMA, STIS/CCD Special Requirements: AFTER 25 BY 75 D TO 105 D; ON HOLD <i>On Hold Comments: Awaiting ToO Trigger.</i>											
	(Visit 27) Warning (Orbit Planner): ORBITAL VISIBILITY OVERRUN (Visit 27) Warning (Orbit Planner): ORBITAL VISIBILITY OVERRUN											
Diagnosics												
Patterns	#	Primary Pattern				Secondary Pattern				Exposures		
	(1)	Pattern Type=STIS-ALONG-SLIT		Coordinate Frame=POS-TARG						(2), (3)		
		Purpose=DITHER		Pattern Orientation=90.0								
		Number Of Points=3		Angle Between Sides=								
		Point Spacing=0.4165		Center Pattern=false								
		Line Spacing=										
Generic Targets	#	Name		Criteria			Description					
	(5)	TDF5		Tidal Disruption Flare			ACCRETION DISK NUCLEUS					
<i>Comments: Nuclear transient not obviously AGN or supernova at z <~ 0.3.</i>												
Exposures	#	Label (ETC Run)	Target	Config,Mode,Aperture		Spectral Els.	Opt. Params.	Special Reqs.	Groups	Exp. Time (Total)/[Actual Dur.]		Orbit
	1	(STIS.ta.100 3503)	(5) TDF5	STIS/CCD, ACQ, F28X50LP		MIRROR				100 Secs (100 Secs)		
											[==>]	[1]
	2	(STIS.sp.10 03504)	(5) TDF5	STIS/NUV-MAMA, ACCUM, 52X0.2		G230L 2376 A			Pattern 1, Exps 2-2 in Visit 27 (1)	600. Secs (1800 Secs)		
											[==>(Pattern 1)]	
										[==>(Pattern 2)]	[1]	
										[==>(Pattern 3)]		
3	(STIS.sp.10 03504)	(5) TDF5	STIS/NUV-MAMA, ACCUM, 52X0.2		G230L 2376 A			Pattern 1, Exps 3-3 in Visit 27 (1)	885. Secs (2655 Secs)			
										[==>(Pattern 1)]		
										[==>(Pattern 2)]	[2]	
										[==>(Pattern 3)]		

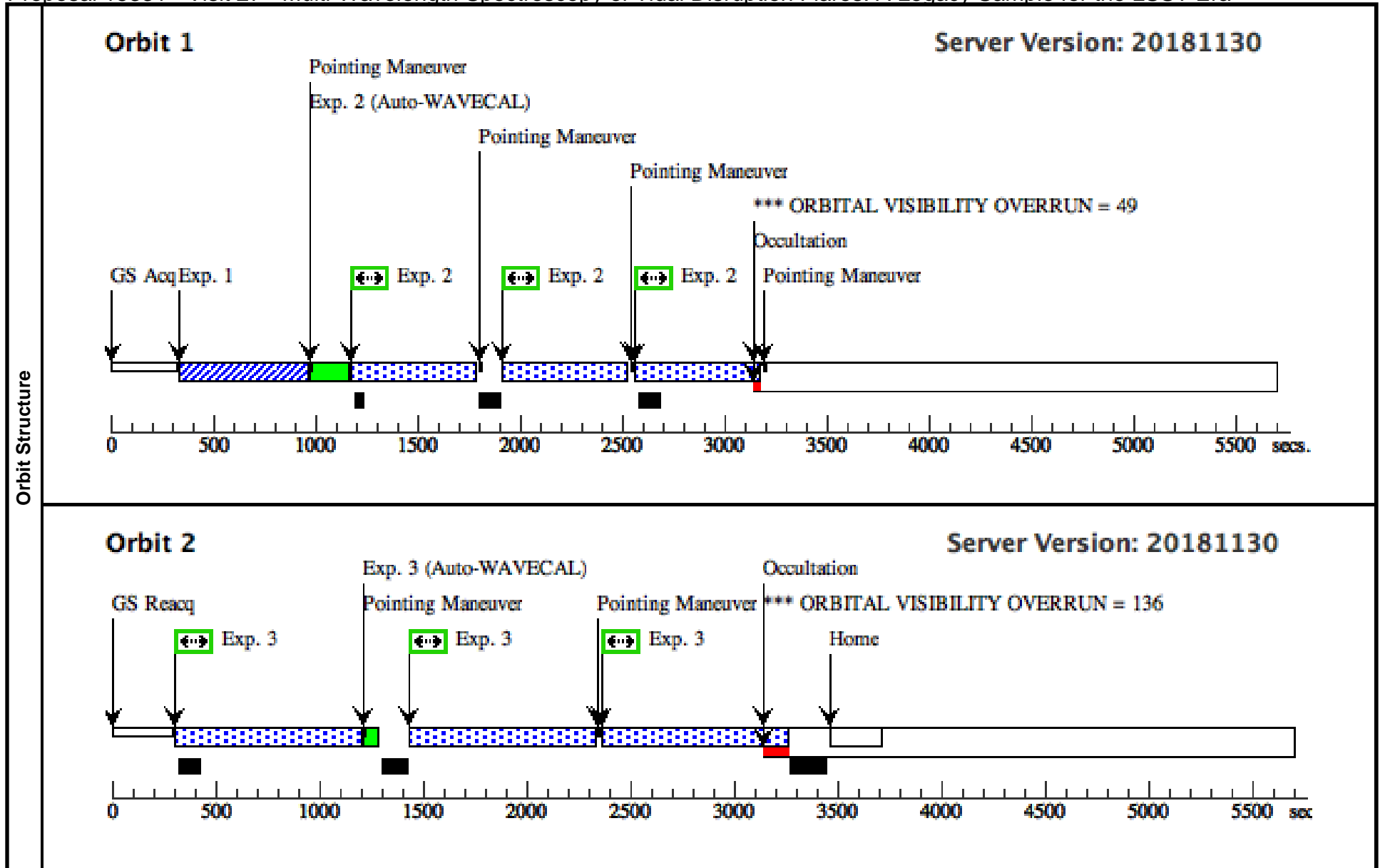

Proposal 15331 - Visit 28 - Multi-Wavelength Spectroscopy of Tidal Disruption Flares: A Legacy Sample for the LSST Era

Fri Jan 25 14:01:47 GMT 2019

Visit	Proposal 15331, Visit 28, withdrawn Diagnostic Status: Warning Scientific Instruments: STIS/CCD, STIS/FUV-MAMA Special Requirements: AFTER 25 BY 75 D TO 105 D; ON HOLD <i>On Hold Comments: Awaiting ToO Trigger.</i>										
	(Visit 28) Warning (Orbit Planner): ORBITAL VISIBILITY OVERRUN (Visit 28) Warning (Orbit Planner): ORBITAL VISIBILITY OVERRUN										
Diagnosics											
Patterns	#	Primary Pattern				Secondary Pattern				Exposures	
	(1)	Pattern Type=STIS-ALONG-SLIT		Coordinate Frame=POS-TARG						(2), (3)	
		Purpose=DITHER		Pattern Orientation=90.0							
		Number Of Points=3		Angle Between Sides=							
		Point Spacing=0.4165		Center Pattern=false							
		Line Spacing=									
Generic Targets	#	Name		Criteria		Description					
	(5)	TDF5		Tidal Disruption Flare		ACCRETION DISK NUCLEUS					
<i>Comments: Nuclear transient not obviously AGN or supernova at z <~ 0.3.</i>											
Exposures	#	Label (ETC Run)	Target	Config,Mode,Aperture	Spectral Els.	Opt. Params.	Special Reqs.	Groups	Exp. Time (Total)/[Actual Dur.]		Orbit
	1	(STIS.ta.100 3503)	(5) TDF5	STIS/CCD, ACQ, F28X50LP	MIRROR				100 Secs (100 Secs)		
										[==>]	[1]
	2	(STIS.sp.10 03505)	(5) TDF5	STIS/FUV-MAMA, ACCUM, 52X0.2	G140L 1425 A			Pattern 1, Exps 2-2 in Visit 28 (1)	600. Secs (1800 Secs)		
										[==>(Pattern 1)]	[1]
									[==>(Pattern 2)]		
									[==>(Pattern 3)]		
3	(STIS.sp.10 03505)	(5) TDF5	STIS/FUV-MAMA, ACCUM, 52X0.2	G140L 1425 A			Pattern 1, Exps 3-3 in Visit 28 (1)	885. Secs (2655 Secs)			
									[==>(Pattern 1)]		
									[==>(Pattern 2)]	[2]	
									[==>(Pattern 3)]		

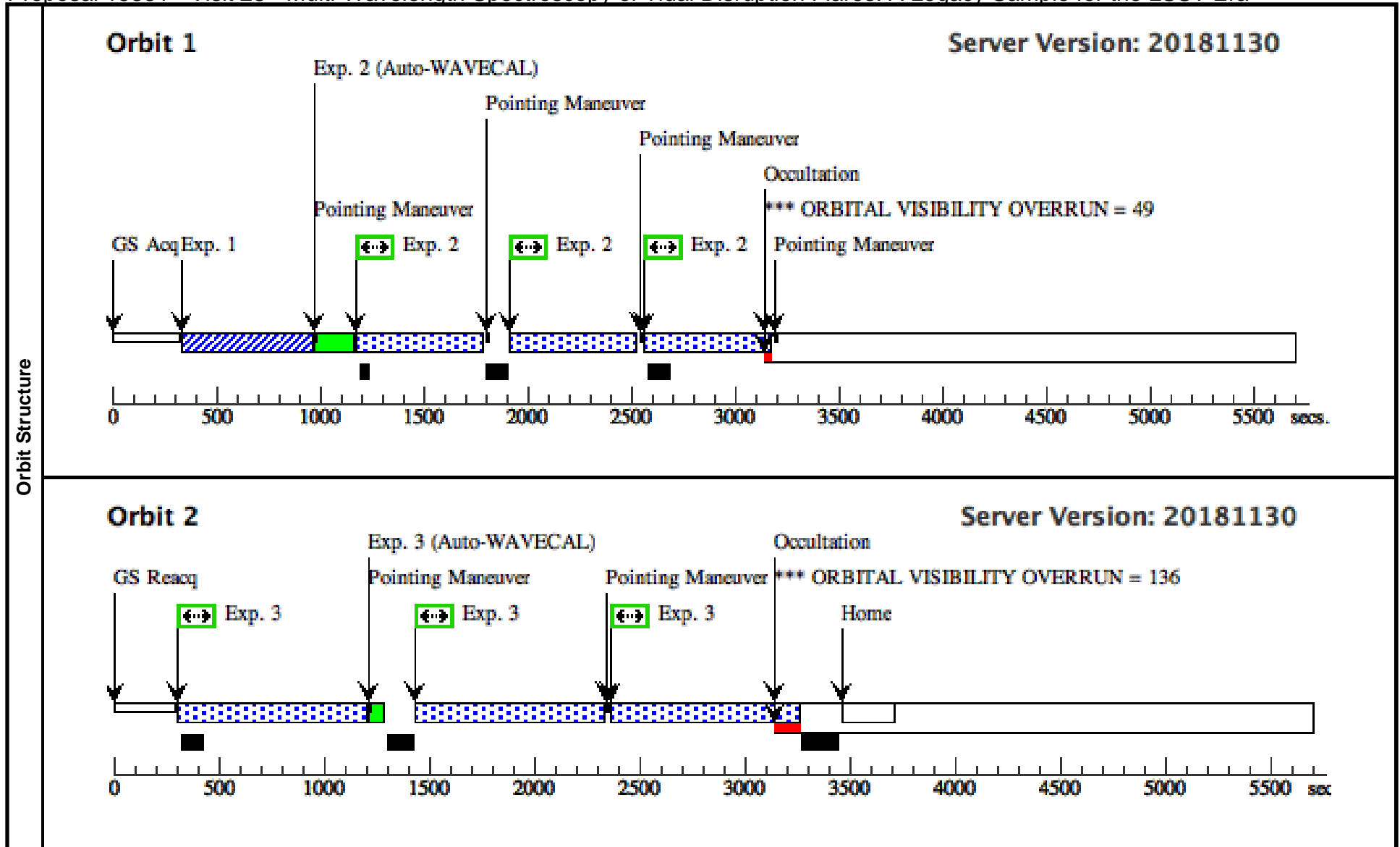

Proposal 15331 - Visit 29 - Multi-Wavelength Spectroscopy of Tidal Disruption Flares: A Legacy Sample for the LSST Era

Fri Jan 25 14:01:47 GMT 2019

Visit	Proposal 15331, Visit 29, withdrawn Diagnostic Status: Warning Scientific Instruments: STIS/NUV-MAMA, STIS/CCD Special Requirements: AFTER 25 BY 150 D TO 210 D; ON HOLD <i>On Hold Comments: Awaiting ToO Trigger.</i>										
	(Visit 29) Warning (Orbit Planner): ORBITAL VISIBILITY OVERRUN (Visit 29) Warning (Orbit Planner): ORBITAL VISIBILITY OVERRUN (Visit 29) Warning (Orbit Planner): ORBITAL VISIBILITY OVERRUN										
Diagnosics											
Patterns	#	Primary Pattern				Secondary Pattern				Exposures	
	(1)	Pattern Type=STIS-ALONG-SLIT Purpose=DITHER Number Of Points=3 Point Spacing=0.4165 Line Spacing=		Coordinate Frame=POS-TARG Pattern Orientation=90.0 Angle Between Sides= Center Pattern=false						(2), (3), (4)	
Generic Targets	#	Name	Criteria			Description					
	(5)	TDF5	Tidal Disruption Flare			ACCRETION DISK NUCLEUS <i>Comments: Nuclear transient not obviously AGN or supernova at z <- 0.3.</i>					
Exposures	#	Label (ETC Run)	Target	Config,Mode,Aperture	Spectral Els.	Opt. Params.	Special Reqs.	Groups	Exp. Time (Total)/[Actual Dur.]		Orbit
	1	(STIS.ta.100 3507)	(5) TDF5	STIS/CCD, ACQ, 50CCD	MIRROR				60 Secs (60 Secs)		
									[==>]		[1]
	2	(STIS.sp.10 03509)	(5) TDF5	STIS/NUV-MAMA, ACCUM, 52X0.2	G230L 2376 A			Pattern 1, Exps 2-2 in Visit 29 (1)	650. Secs (1950 Secs)		
									[==>(Pattern 1)]		[1]
								[==>(Pattern 2)]			
								[==>(Pattern 3)]			
3	(STIS.sp.10 03509)	(5) TDF5	STIS/NUV-MAMA, ACCUM, 52X0.2	G230L 2376 A			Pattern 1, Exps 3-3 in Visit 29 (1)	885. Secs (2655 Secs)			
								[==>(Pattern 1)]		[2]	
								[==>(Pattern 2)]			
								[==>(Pattern 3)]			
4	(STIS.sp.10 03509)	(5) TDF5	STIS/NUV-MAMA, ACCUM, 52X0.2	G230L 2376 A			Pattern 1, Exps 4-4 in Visit 29 (1)	885. Secs (2655 Secs)			
								[==>(Pattern 1)]		[3]	
								[==>(Pattern 2)]			
								[==>(Pattern 3)]			

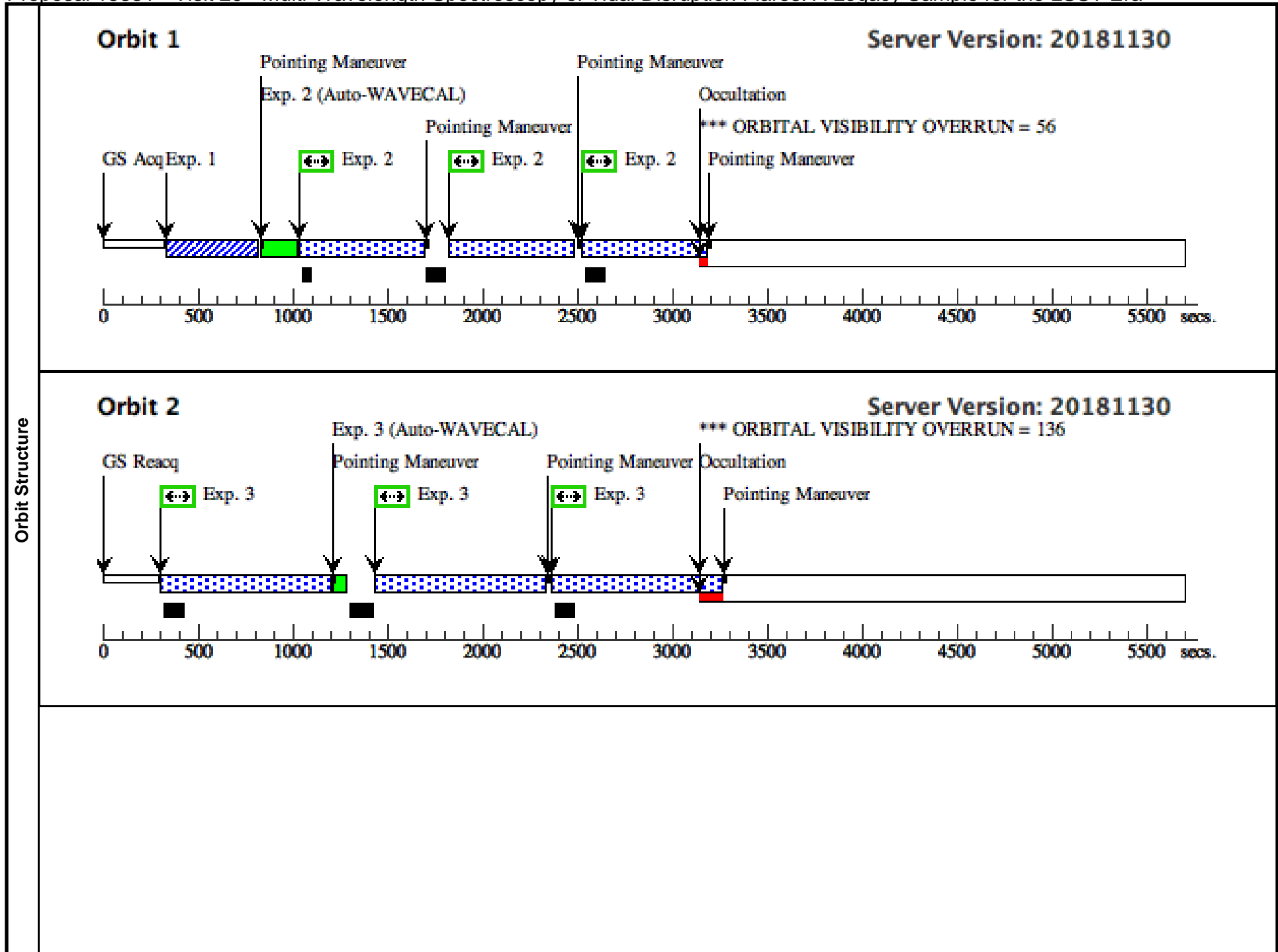

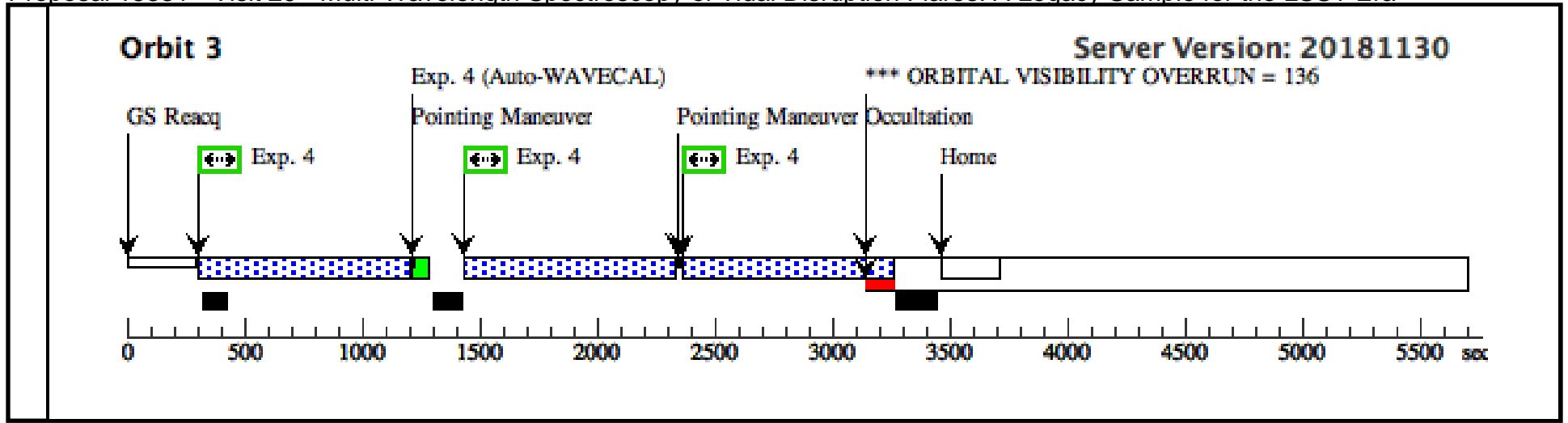

Proposal 15331 - Visit 30 - Multi-Wavelength Spectroscopy of Tidal Disruption Flares: A Legacy Sample for the LSST Era

Fri Jan 25 14:01:47 GMT 2019

Visit	Proposal 15331, Visit 30, withdrawn Diagnostic Status: Warning Scientific Instruments: STIS/CCD, STIS/FUV-MAMA Special Requirements: AFTER 25 BY 150 D TO 210 D; ON HOLD <i>On Hold Comments: Awaiting ToO Trigger.</i>										
	(Visit 30) Warning (Orbit Planner): ORBITAL VISIBILITY OVERRUN (Visit 30) Warning (Orbit Planner): ORBITAL VISIBILITY OVERRUN (Visit 30) Warning (Orbit Planner): ORBITAL VISIBILITY OVERRUN										
Diagnosics											
Patterns	#	Primary Pattern				Secondary Pattern				Exposures	
	(1)	Pattern Type=STIS-ALONG-SLIT		Coordinate Frame=POS-TARG						(2), (3), (4)	
		Purpose=DITHER		Pattern Orientation=90.0							
		Number Of Points=3		Angle Between Sides=							
		Point Spacing=0.4165		Center Pattern=false							
		Line Spacing=									
Generic Targets	#	Name	Criteria			Description					
	(5)	TDF5	Tidal Disruption Flare			ACCRETION DISK NUCLEUS					
<i>Comments: Nuclear transient not obviously AGN or supernova at z <- 0.3.</i>											
Exposures	#	Label (ETC Run)	Target	Config,Mode,Aperture	Spectral Els.	Opt. Params.	Special Reqs.	Groups	Exp. Time (Total)/[Actual Dur.]		Orbit
	1	(STIS.ta.100 3507)	(5) TDF5	STIS/CCD, ACQ, 50CCD	MIRROR				60 Secs (60 Secs)		
										[==>]	[1]
	2	(STIS.sp.10 03510)	(5) TDF5	STIS/FUV-MAMA, ACCUM, 52X0.2	G140L 1425 A			Pattern 1, Exps 2-2 in Visit 30 (1)	650. Secs (1950 Secs)		
										[==>(Pattern 1)]	[1]
									[==>(Pattern 2)]		
									[==>(Pattern 3)]		
3	(STIS.sp.10 03510)	(5) TDF5	STIS/FUV-MAMA, ACCUM, 52X0.2	G140L 1425 A			Pattern 1, Exps 3-3 in Visit 30 (1)	885. Secs (2655 Secs)			
									[==>(Pattern 1)]	[2]	
									[==>(Pattern 2)]		
									[==>(Pattern 3)]		
4	(STIS.sp.10 03510)	(5) TDF5	STIS/FUV-MAMA, ACCUM, 52X0.2	G140L 1425 A			Pattern 1, Exps 4-4 in Visit 30 (1)	885. Secs (2655 Secs)			
									[==>(Pattern 1)]	[3]	
									[==>(Pattern 2)]		
									[==>(Pattern 3)]		

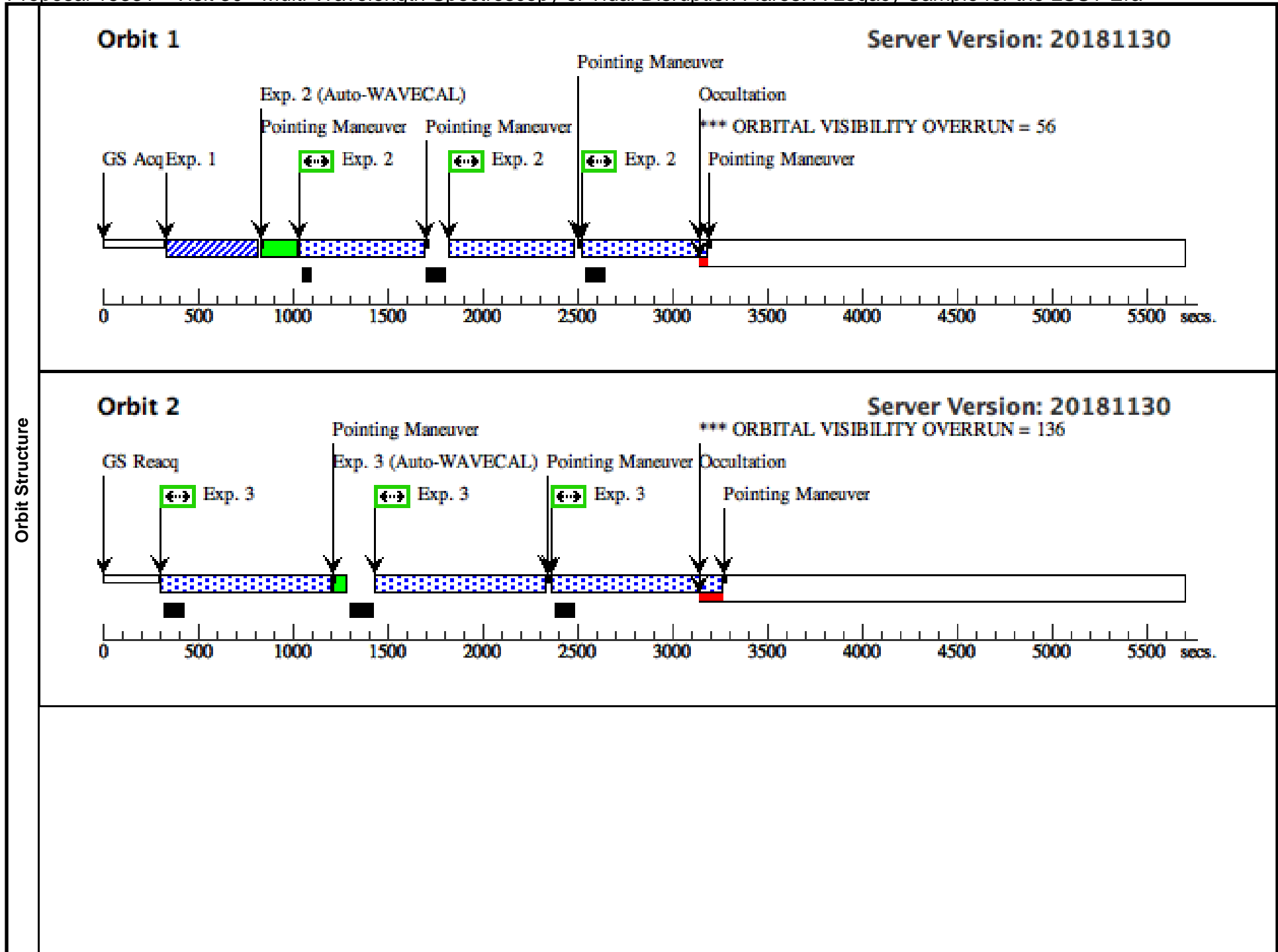

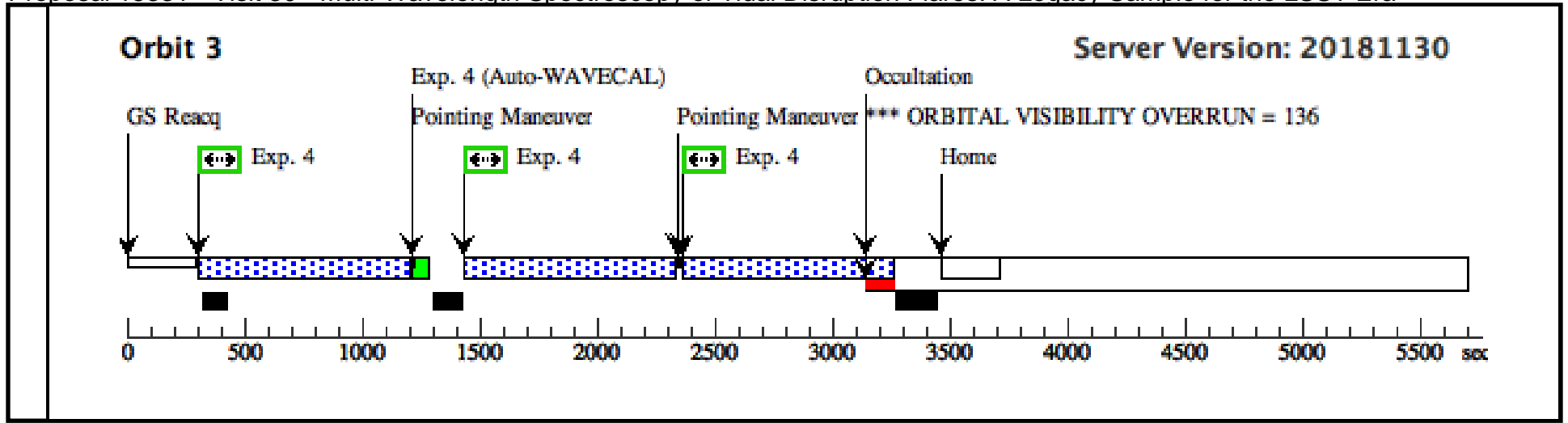

Proposal 15331 - Visit 31 - Multi-Wavelength Spectroscopy of Tidal Disruption Flares: A Legacy Sample for the LSST Era

Fri Jan 25 14:01:48 GMT 2019

Visit	Proposal 15331, Visit 31, completed Diagnostic Status: Warning Scientific Instruments: STIS/NUV-MAMA, STIS/CCD, STIS/FUV-MAMA Special Requirements: BETWEEN 28-MAR-2018:00:00:00 AND 13-APR-2018:00:00:00									
	(Visit 31) Warning (Orbit Planner): ORBITAL VISIBILITY OVERRUN (Visit 31) Warning (Orbit Planner): ORBITAL VISIBILITY OVERRUN									
Diagnosics										
Patterns	#	Primary Pattern				Secondary Pattern				Exposures
	(1)	Pattern Type=STIS-ALONG-SLIT Purpose=DITHER Number Of Points=3 Point Spacing=0.4165 Line Spacing=		Coordinate Frame=POS-TARG Pattern Orientation=90.0 Angle Between Sides= Center Pattern=false						(2), (3), (4)
Fixed Targets	#	Name	Target Coordinates		Targ. Coord. Corrections		Fluxes	Miscellaneous		
	(6)	AT2018ZR	RA: 07 56 54.5489 (119.2272871d) Dec: +34 15 43.63 (34.26212d) Equinox: J2000				V=18.0	Reference Frame: ICRS		
Comments: Category=GALAXY Description=[ACCRETION DISK]										
Exposures	#	Label (ETC Run)	Target	Config,Mode,Aperture	Spectral Els.	Opt. Params.	Special Reqs.	Groups	Exp. Time (Total)/[Actual Dur.]	Orbit
	1	(STIS.ta.115 6104)	(6) AT2018ZR	STIS/CCD, ACQ, F28X50LP	MIRROR				30 Secs (30 Secs)	
									[==>]	[1]
	2	(STIS.sp.11 56105)	(6) AT2018ZR	STIS/NUV-MAMA, ACCUM, 52X0.2	G230L 2376 A			Pattern 1, Exps 2-2 in Visit 31 (1)	674 Secs (2022 Secs)	
									[==>(Pattern 1)] [==>(Pattern 2)] [==>(Pattern 3)]	[1]
3	(STIS.sp.11 56106)	(6) AT2018ZR	STIS/FUV-MAMA, ACCUM, 52X0.2	G140L 1425 A			Pattern 1, Exps 3-3 in Visit 31 (1)	920 Secs (2760 Secs)		
								[==>(Pattern 1)] [==>(Pattern 2)] [==>(Pattern 3)]	[2]	
4	(STIS.sp.11 56106)	(6) AT2018ZR	STIS/FUV-MAMA, ACCUM, 52X0.2	G140L 1425 A			Pattern 1, Exps 4-4 in Visit 31 (1)	920 Secs (2760 Secs)		
								[==>(Pattern 1)] [==>(Pattern 2)] [==>(Pattern 3)]	[3]	

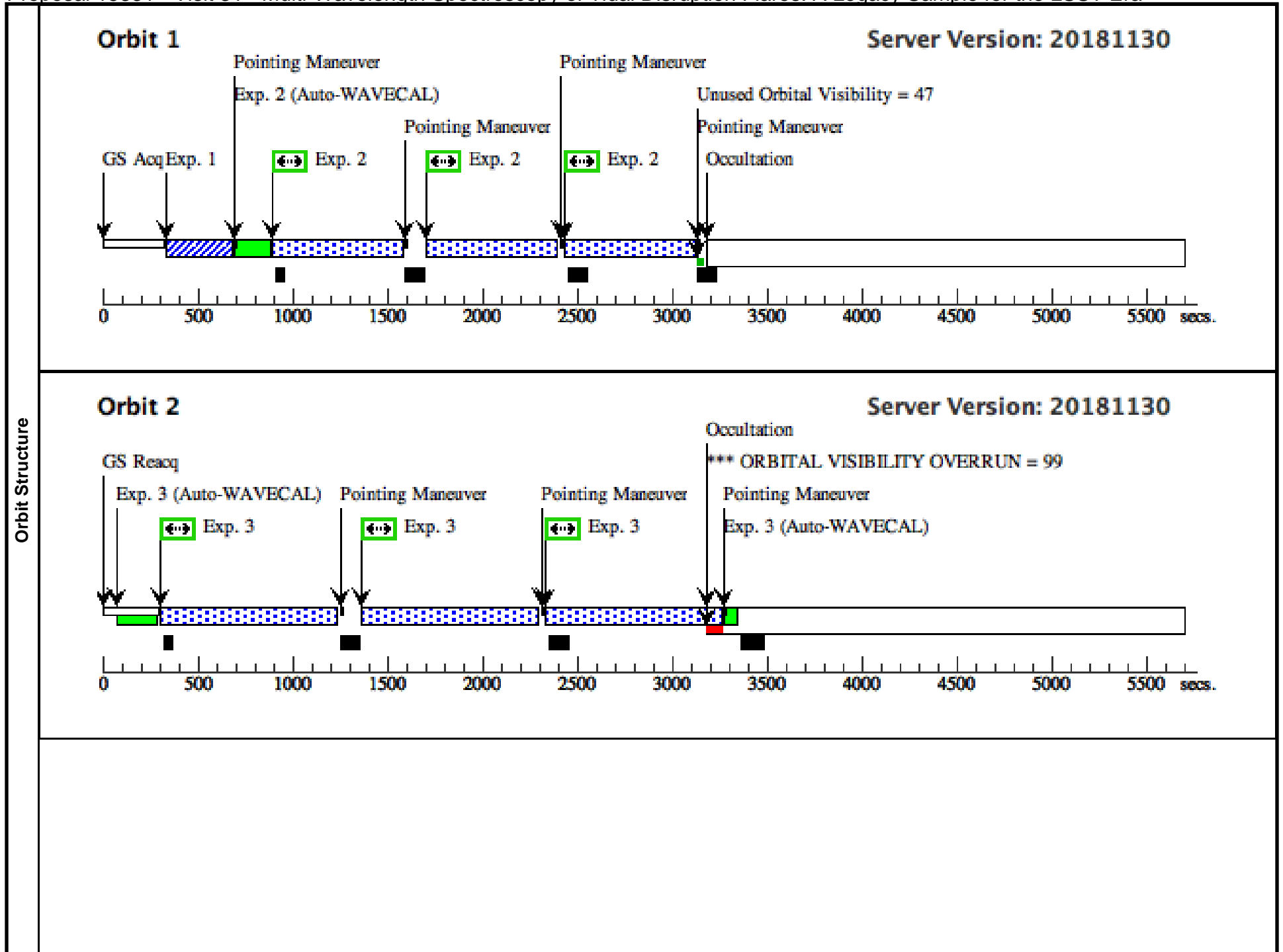

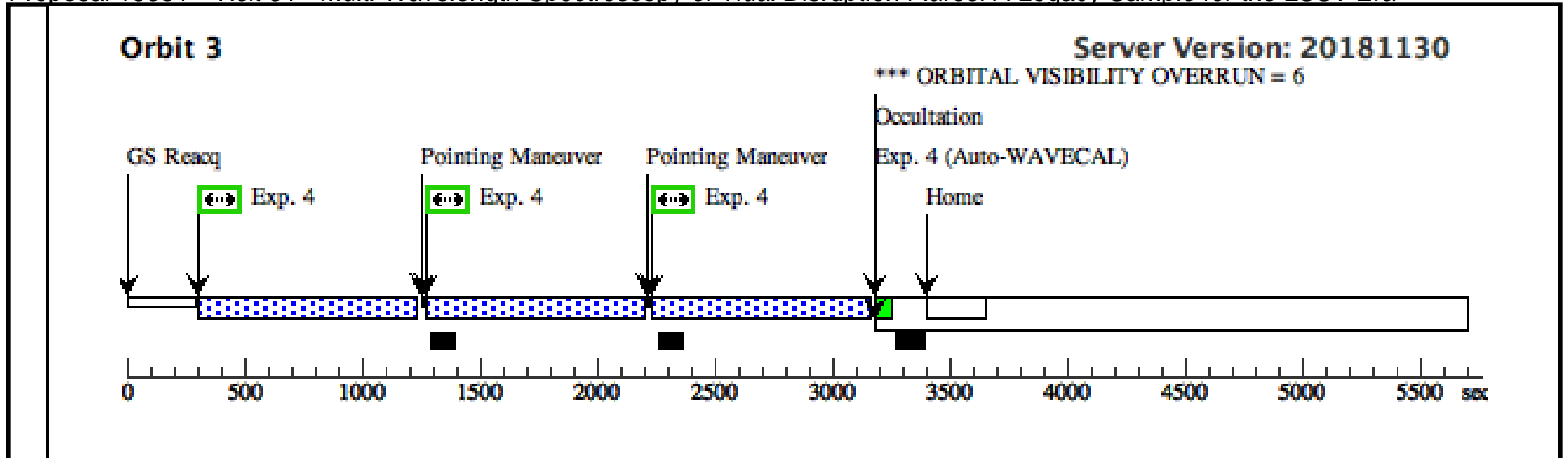

Proposal 15331 - Visit 36 - Multi-Wavelength Spectroscopy of Tidal Disruption Flares: A Legacy Sample for the LSST Era

Fri Jan 25 14:01:48 GMT 2019

Visit	Proposal 15331, Visit 36, completed Diagnostic Status: Warning Scientific Instruments: STIS/NUV-MAMA, STIS/CCD Special Requirements: BETWEEN 24-SEP-2018:00:00:00 AND 05-OCT-2018:00:00:00										
	(Visit 36) Warning (Orbit Planner): ORBITAL VISIBILITY OVERRUN (Visit 36) Warning (Orbit Planner): ORBITAL VISIBILITY OVERRUN										
Diagnosics											
Patterns	#	Primary Pattern				Secondary Pattern				Exposures	
	(1)	Pattern Type=STIS-ALONG-SLIT		Coordinate Frame=POS-TARG						(2), (3), (4)	
		Purpose=DITHER		Pattern Orientation=90.0							
		Number Of Points=3		Angle Between Sides=							
		Point Spacing=0.4165		Center Pattern=false							
		Line Spacing=									
Fixed Targets	#	Name	Target Coordinates		Targ. Coord. Corrections		Fluxes		Miscellaneous		
	(9)	ZTF18AAHQKBT	RA: 08 15 26.6200 (123.8609167d) Dec: +45 35 31.90 (45.59219d) Equinox: J2000				V=19.0		Reference Frame: ICRS		
Comments: Category=GALAXY Description=[ACCRETION DISK, NUCLEUS]											
Exposures	#	Label (ETC Run)	Target	Config,Mode,Aperture	Spectral Els.	Opt. Params.	Special Reqs.	Groups	Exp. Time (Total)/[Actual Dur.]		Orbit
	1	(STIS.ta.128 8507)	(9) ZTF18AAHQKB T	STIS/CCD, ACQ, F28X50LP	MIRROR				60 Secs (60 Secs)		
										[==>]	[1]
	2	(STIS.sp.12 88508)	(9) ZTF18AAHQKB T	STIS/NUV-MAMA, ACCUM, 52X0.2	G230L 2376 A			Pattern 1, Exps 2-2 in Visit 36 (1)	660 Secs (1980 Secs)		
										[==>(Pattern 1)]	
										[==>(Pattern 2)]	[1]
									[==>(Pattern 3)]		
3	(STIS.sp.12 88508)	(9) ZTF18AAHQKB T	STIS/NUV-MAMA, ACCUM, 52X0.2	G230L 2376 A			Pattern 1, Exps 3-3 in Visit 36 (1)	890 Secs (2670 Secs)			
									[==>(Pattern 1)]		
									[==>(Pattern 2)]	[2]	
									[==>(Pattern 3)]		
4	(STIS.sp.12 88508)	(9) ZTF18AAHQKB T	STIS/NUV-MAMA, ACCUM, 52X0.2	G230L 2376 A			Pattern 1, Exps 4-4 in Visit 36 (1)	890 Secs (2670 Secs)			
									[==>(Pattern 1)]		
									[==>(Pattern 2)]	[3]	
									[==>(Pattern 3)]		

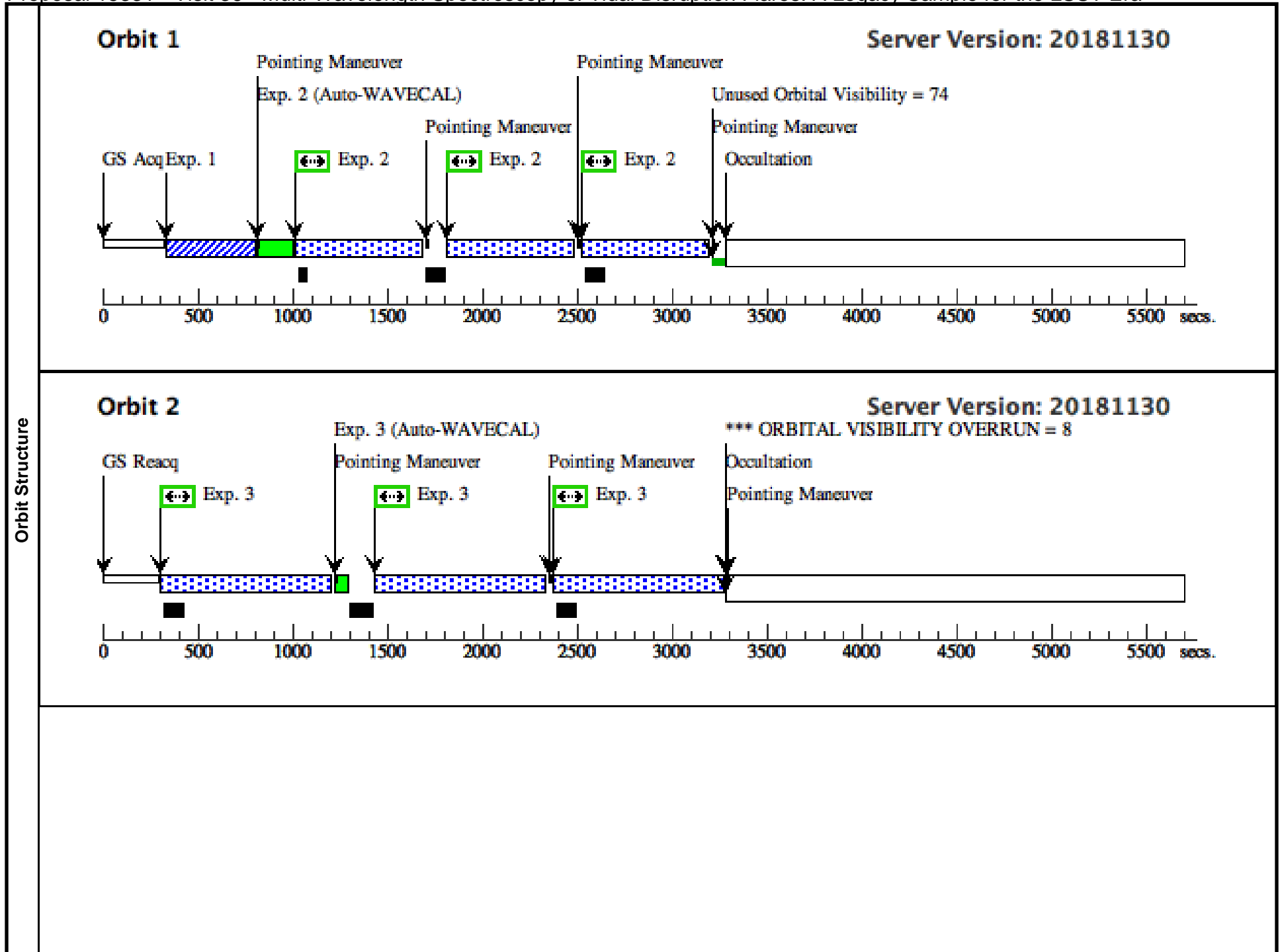

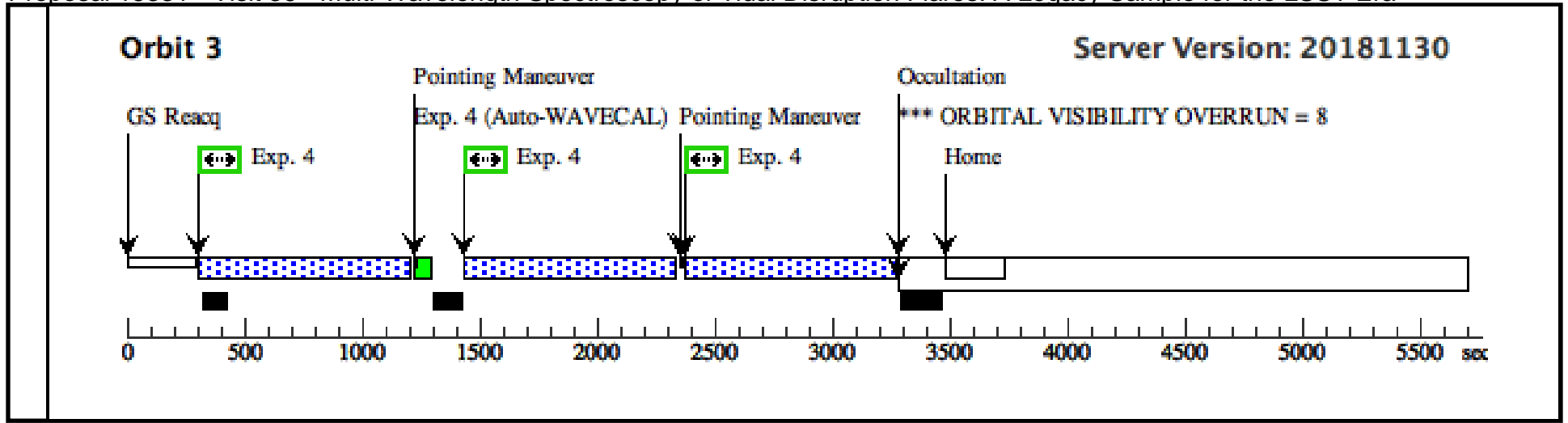

Proposal 15331 - Visit 37 - Multi-Wavelength Spectroscopy of Tidal Disruption Flares: A Legacy Sample for the LSST Era

Fri Jan 25 14:01:48 GMT 2019

Visit	Proposal 15331, Visit 37, completed Diagnostic Status: Warning Scientific Instruments: STIS/CCD, STIS/FUV-MAMA Special Requirements: BETWEEN 24-SEP-2018:00:00:00 AND 05-OCT-2018:00:00:00										
	(Visit 37) Warning (Orbit Planner): ORBITAL VISIBILITY OVERRUN (Visit 37) Warning (Orbit Planner): ORBITAL VISIBILITY OVERRUN										
Diagnosics											
Patterns	#	Primary Pattern				Secondary Pattern				Exposures	
	(1)	Pattern Type=STIS-ALONG-SLIT		Coordinate Frame=POS-TARG						(2), (3), (4)	
		Purpose=DITHER		Pattern Orientation=90.0							
		Number Of Points=3		Angle Between Sides=							
		Point Spacing=0.4165		Center Pattern=false							
		Line Spacing=									
Fixed Targets	#	Name	Target Coordinates		Targ. Coord. Corrections		Fluxes	Miscellaneous			
	(9)	ZTF18AAHQKBT	RA: 08 15 26.6200 (123.8609167d) Dec: +45 35 31.90 (45.59219d) Equinox: J2000				V=19.0	Reference Frame: ICRS			
Comments: Category=GALAXY Description=[ACCRETION DISK, NUCLEUS]											
Exposures	#	Label (ETC Run)	Target	Config,Mode,Aperture	Spectral Els.	Opt. Params.	Special Reqs.	Groups	Exp. Time (Total)/[Actual Dur.]		Orbit
	1	(STIS.ta.128 8507)	(9) ZTF18AAHQKB T	STIS/CCD, ACQ, F28X50LP	MIRROR				60 Secs (60 Secs)		
										[==>]	[1]
	2	(STIS.sp.12 88509)	(9) ZTF18AAHQKB T	STIS/FUV-MAMA, ACCUM, 52X0.2	G140L 1425 A			Pattern 1, Exps 2-2 in Visit 37 (1)	660 Secs (1980 Secs)		
										[==>(Pattern 1)]	
										[==>(Pattern 2)]	[1]
									[==>(Pattern 3)]		
3	(STIS.sp.12 88509)	(9) ZTF18AAHQKB T	STIS/FUV-MAMA, ACCUM, 52X0.2	G140L 1425 A			Pattern 1, Exps 3-3 in Visit 37 (1)	890 Secs (2670 Secs)			
									[==>(Pattern 1)]		
									[==>(Pattern 2)]	[2]	
									[==>(Pattern 3)]		
4	(STIS.sp.12 88509)	(9) ZTF18AAHQKB T	STIS/FUV-MAMA, ACCUM, 52X0.2	G140L 1425 A			Pattern 1, Exps 4-4 in Visit 37 (1)	890 Secs (2670 Secs)			
									[==>(Pattern 1)]		
									[==>(Pattern 2)]	[3]	
									[==>(Pattern 3)]		

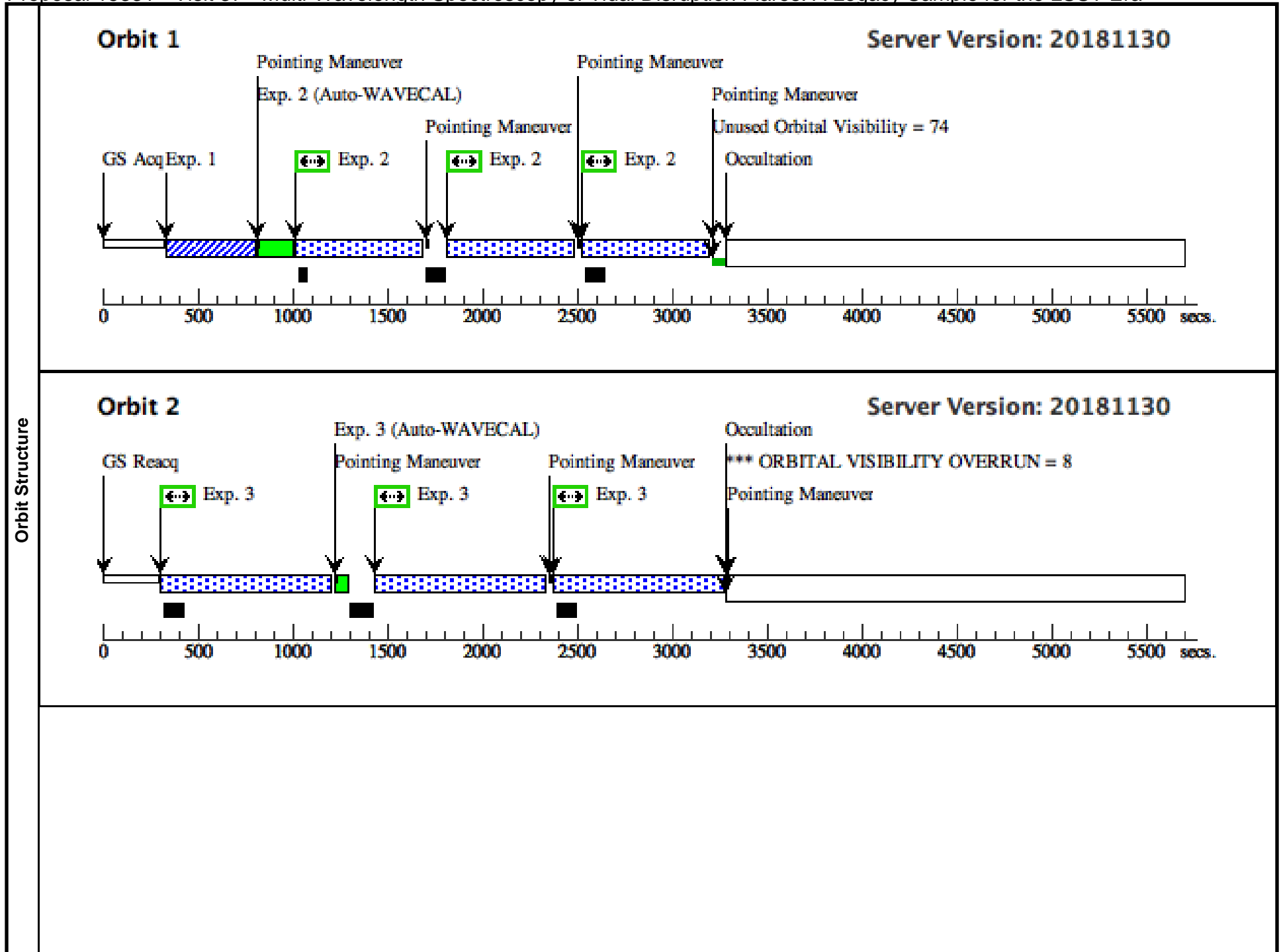

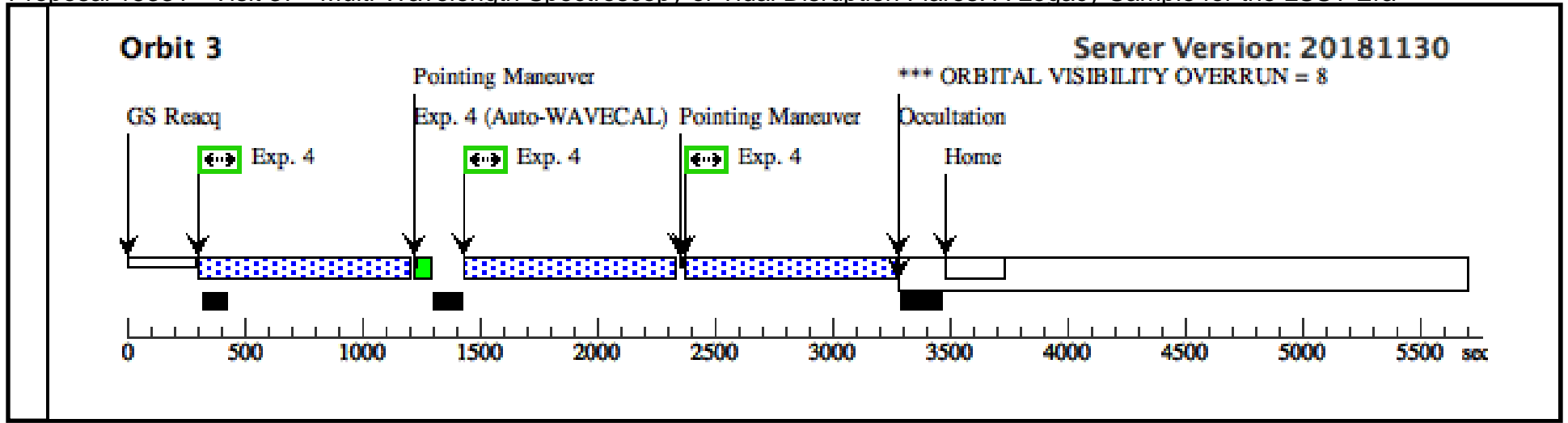

Proposal 15331 - Visit 32 - Multi-Wavelength Spectroscopy of Tidal Disruption Flares: A Legacy Sample for the LSST Era

Fri Jan 25 14:01:48 GMT 2019

Visit	Proposal 15331, Visit 32, completed Diagnostic Status: Warning Scientific Instruments: STIS/NUV-MAMA, STIS/CCD, STIS/FUV-MAMA Special Requirements: BETWEEN 25-APR-2018:00:00:00 AND 02-MAY-2018:00:00:00										
	(Visit 32) Warning (Orbit Planner): ORBITAL VISIBILITY OVERRUN (Visit 32) Warning (Orbit Planner): ORBITAL VISIBILITY OVERRUN (Visit 32) Warning (Orbit Planner): ORBITAL VISIBILITY OVERRUN										
Diagnosics											
Patterns	#	Primary Pattern				Secondary Pattern				Exposures	
	(1)	Pattern Type=STIS-ALONG-SLIT		Coordinate Frame=POS-TARG						(2), (3), (4)	
		Purpose=DITHER		Pattern Orientation=90.0							
		Number Of Points=3		Angle Between Sides=							
		Point Spacing=0.4165		Center Pattern=false							
		Line Spacing=									
Fixed Targets	#	Name	Target Coordinates		Targ. Coord. Corrections		Fluxes		Miscellaneous		
	(6)	AT2018ZR	RA: 07 56 54.5489 (119.2272871d) Dec: +34 15 43.63 (34.26212d) Equinox: J2000				V=18.0		Reference Frame: ICRS		
		Comments: Category=GALAXY Description=[ACCRETION DISK]									
Exposures	#	Label (ETC Run)	Target	Config,Mode,Aperture	Spectral Els.	Opt. Params.	Special Reqs.	Groups	Exp. Time (Total)/[Actual Dur.]		Orbit
	1		(6) AT2018ZR	STIS/CCD, ACQ, F28X50LP	MIRROR				45 Secs (45 Secs)		
									[==>]		[1]
	2	(STIS.sp.11 56105)	(6) AT2018ZR	STIS/NUV-MAMA, ACCUM, 52X0.2	G230L 2376 A			Pattern 1, Exps 2-2 in Visit 32 (1)	674 Secs (2022 Secs)		
									[==>(Pattern 1)]		
									[==>(Pattern 2)]		[1]
									[==>(Pattern 3)]		
	3	(STIS.sp.11 56106)	(6) AT2018ZR	STIS/FUV-MAMA, ACCUM, 52X0.2	G140L 1425 A			Pattern 1, Exps 3-3 in Visit 32 (1)	920 Secs (2760 Secs)		
									[==>(Pattern 1)]		
									[==>(Pattern 2)]		[2]
								[==>(Pattern 3)]			
4	(STIS.sp.11 56106)	(6) AT2018ZR	STIS/FUV-MAMA, ACCUM, 52X0.2	G140L 1425 A			Pattern 1, Exps 4-4 in Visit 32 (1)	920 Secs (2760 Secs)			
								[==>(Pattern 1)]			
								[==>(Pattern 2)]		[3]	
								[==>(Pattern 3)]			

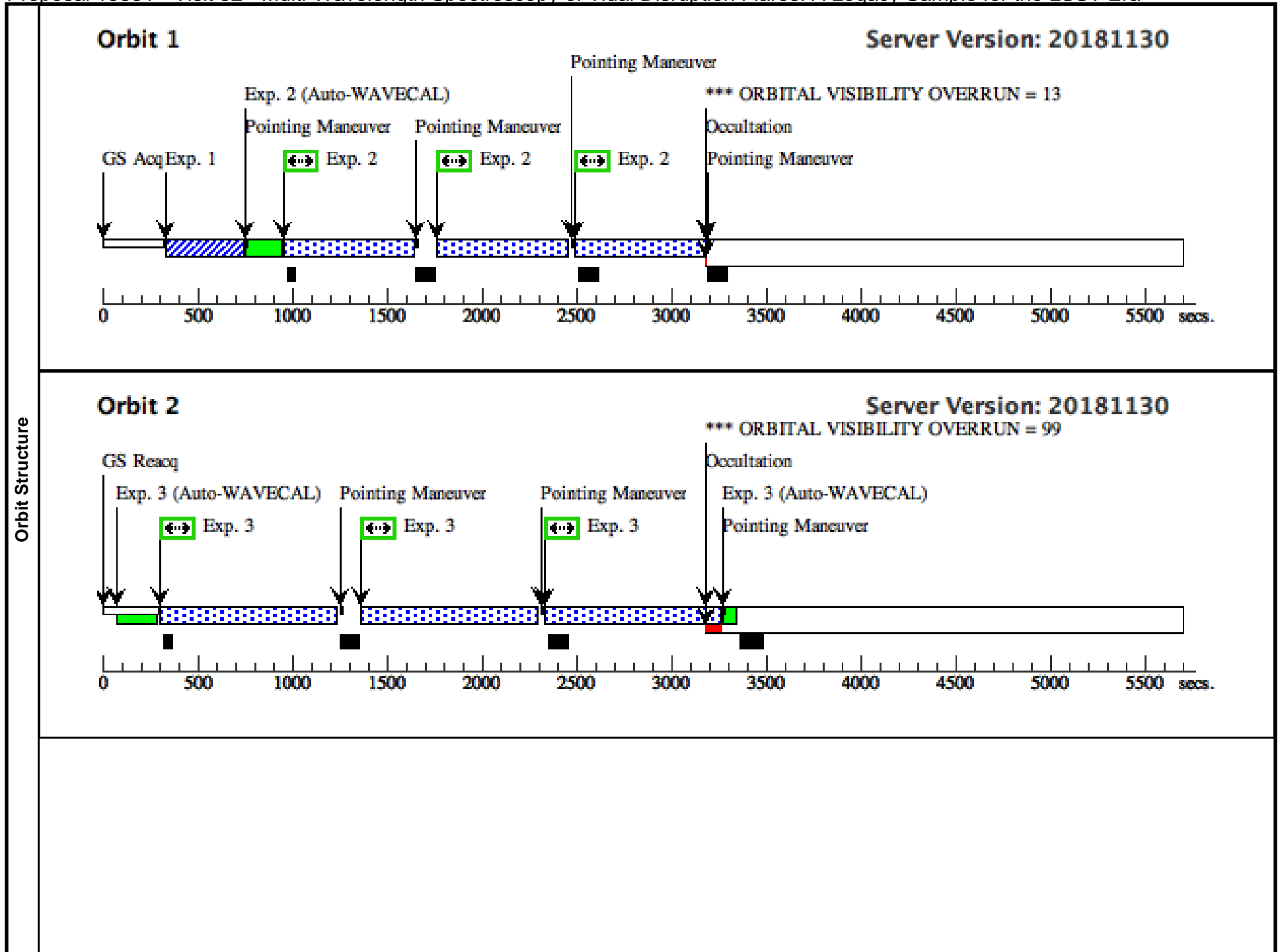

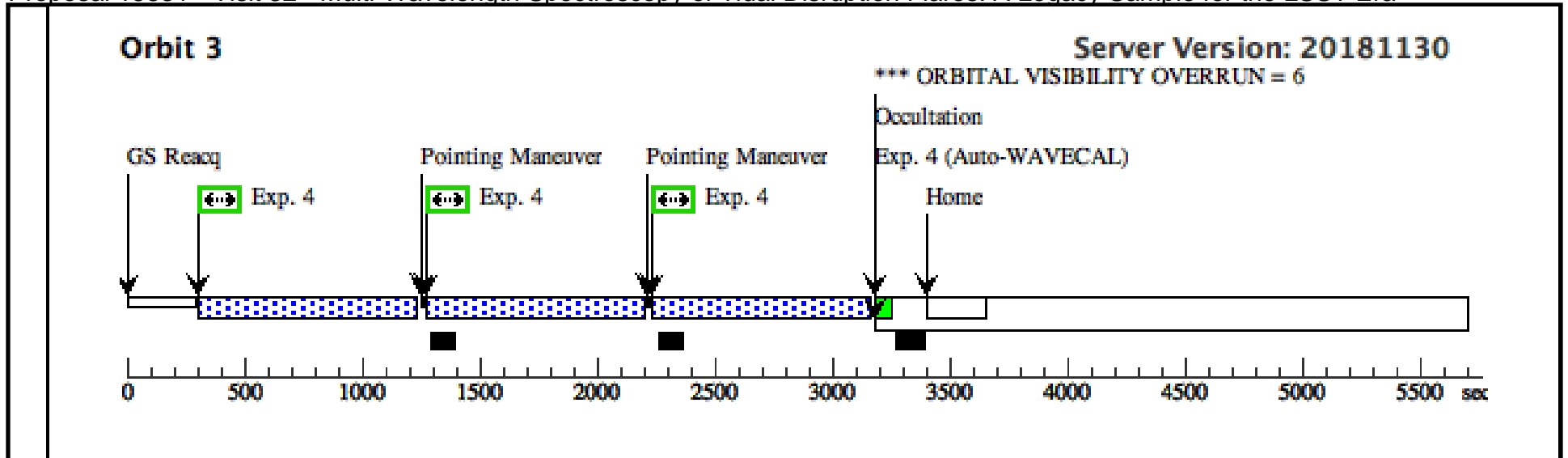

Proposal 15331 - Visit 33 - Multi-Wavelength Spectroscopy of Tidal Disruption Flares: A Legacy Sample for the LSST Era

Fri Jan 25 14:01:48 GMT 2019

Visit	Proposal 15331, Visit 33, completed Diagnostic Status: Warning Scientific Instruments: STIS/NUV-MAMA, STIS/CCD, STIS/FUV-MAMA Special Requirements: BETWEEN 25-APR-2018:00:00:00 AND 02-MAY-2018:00:00:00										
	(Visit 33) Warning (Orbit Planner): ORBITAL VISIBILITY OVERRUN (Visit 33) Warning (Orbit Planner): ORBITAL VISIBILITY OVERRUN (Visit 33) Warning (Orbit Planner): ORBITAL VISIBILITY OVERRUN										
Diagnosics											
Patterns	#	Primary Pattern				Secondary Pattern				Exposures	
	(1)	Pattern Type=STIS-ALONG-SLIT		Coordinate Frame=POS-TARG						(2), (3), (4)	
		Purpose=DITHER		Pattern Orientation=90.0							
		Number Of Points=3		Angle Between Sides=							
		Point Spacing=0.4165		Center Pattern=false							
		Line Spacing=									
Fixed Targets	#	Name	Target Coordinates		Targ. Coord. Corrections		Fluxes		Miscellaneous		
	(6)	AT2018ZR	RA: 07 56 54.5489 (119.2272871d) Dec: +34 15 43.63 (34.26212d) Equinox: J2000				V=18.0		Reference Frame: ICRS		
		Comments: Category=GALAXY Description=[ACCRETION DISK]									
Exposures	#	Label (ETC Run)	Target	Config,Mode,Aperture	Spectral Els.	Opt. Params.	Special Reqs.	Groups	Exp. Time (Total)/[Actual Dur.]		Orbit
	1		(6) AT2018ZR	STIS/CCD, ACQ, F28X50LP	MIRROR				45 Secs (45 Secs)		
									[==>]		[1]
	2	(STIS.sp.11 56105)	(6) AT2018ZR	STIS/NUV-MAMA, ACCUM, 52X0.2	G230L 2376 A			Pattern 1, Exps 2-2 in Visit 33 (1)	674 Secs (2022 Secs)		
									[==>(Pattern 1)]		
									[==>(Pattern 2)]		[1]
									[==>(Pattern 3)]		
	3	(STIS.sp.11 56106)	(6) AT2018ZR	STIS/FUV-MAMA, ACCUM, 52X0.2	G140L 1425 A			Pattern 1, Exps 3-3 in Visit 33 (1)	920 Secs (2760 Secs)		
									[==>(Pattern 1)]		
									[==>(Pattern 2)]		[2]
								[==>(Pattern 3)]			
4	(STIS.sp.11 56106)	(6) AT2018ZR	STIS/FUV-MAMA, ACCUM, 52X0.2	G140L 1425 A			Pattern 1, Exps 4-4 in Visit 33 (1)	920 Secs (2760 Secs)			
								[==>(Pattern 1)]			
								[==>(Pattern 2)]		[3]	
								[==>(Pattern 3)]			

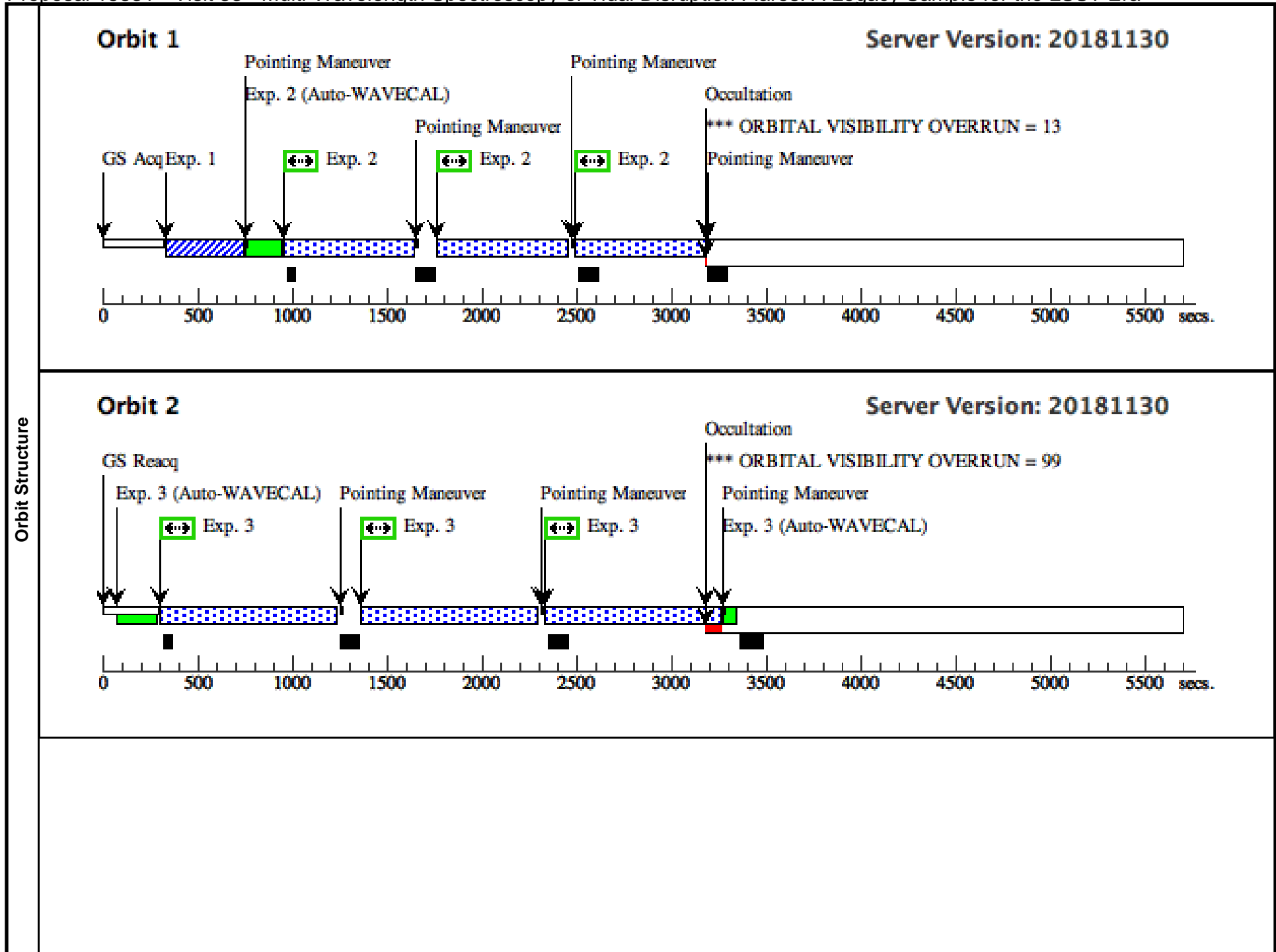

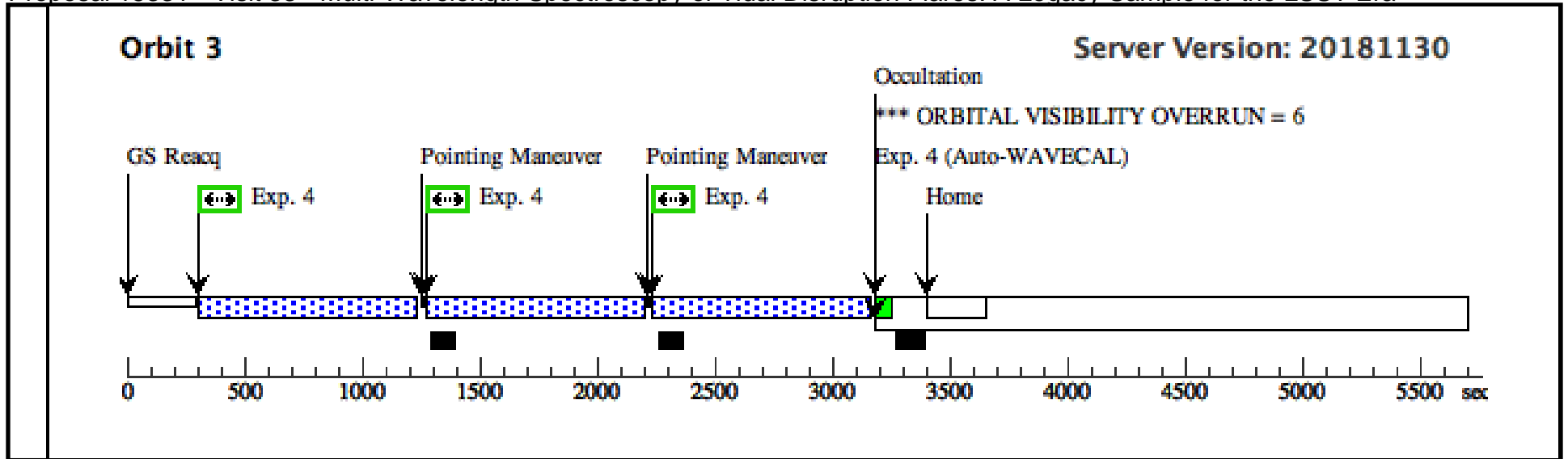

Proposal 15331 - Visit 34 - Multi-Wavelength Spectroscopy of Tidal Disruption Flares: A Legacy Sample for the LSST Era

Fri Jan 25 14:01:48 GMT 2019

Visit	Proposal 15331, Visit 34, completed Diagnostic Status: Warning Scientific Instruments: STIS/NUV-MAMA, STIS/CCD, STIS/FUV-MAMA Special Requirements: BETWEEN 20-MAY-2018:00:00:00 AND 27-MAY-2018:00:00:00									
	(Visit 34) Warning (Orbit Planner): ORBITAL VISIBILITY OVERRUN (Visit 34) Warning (Orbit Planner): ORBITAL VISIBILITY OVERRUN (Visit 34) Warning (Orbit Planner): ORBITAL VISIBILITY OVERRUN									
Diagnosics										
Patterns	#	Primary Pattern				Secondary Pattern				Exposures
	(1)	Pattern Type=STIS-ALONG-SLIT		Coordinate Frame=POS-TARG						(2), (3), (4)
		Purpose=DITHER		Pattern Orientation=90.0						
		Number Of Points=3		Angle Between Sides=						
		Point Spacing=0.4165		Center Pattern=false						
		Line Spacing=								
Fixed Targets	#	Name	Target Coordinates		Targ. Coord. Corrections		Fluxes		Miscellaneous	
	(6)	AT2018ZR	RA: 07 56 54.5489 (119.2272871d) Dec: +34 15 43.63 (34.26212d) Equinox: J2000				V=18.0		Reference Frame: ICRS	
Comments: Category=GALAXY Description=[ACCRETION DISK]										
Exposures	#	Label (ETC Run)	Target	Config,Mode,Aperture	Spectral Els.	Opt. Params.	Special Reqs.	Groups	Exp. Time (Total)/[Actual Dur.]	Orbit
	1		(6) AT2018ZR	STIS/CCD, ACQ, F28X50LP	MIRROR				45 Secs (45 Secs)	
									[==>]	[1]
	2	(STIS.sp.11 56105)	(6) AT2018ZR	STIS/NUV-MAMA, ACCUM, 52X0.2	G230L 2376 A			Pattern 1, Exps 2-2 in Visit 34 (1)	674 Secs (2022 Secs)	
									[==>(Pattern 1)]	
									[==>(Pattern 2)]	[1]
								[==>(Pattern 3)]		
3	(STIS.sp.11 56106)	(6) AT2018ZR	STIS/FUV-MAMA, ACCUM, 52X0.2	G140L 1425 A			Pattern 1, Exps 3-3 in Visit 34 (1)	920 Secs (2760 Secs)		
								[==>(Pattern 1)]		
								[==>(Pattern 2)]	[2]	
								[==>(Pattern 3)]		
4	(STIS.sp.11 56106)	(6) AT2018ZR	STIS/FUV-MAMA, ACCUM, 52X0.2	G140L 1425 A			Pattern 1, Exps 4-4 in Visit 34 (1)	920 Secs (2760 Secs)		
								[==>(Pattern 1)]		
								[==>(Pattern 2)]	[3]	
								[==>(Pattern 3)]		

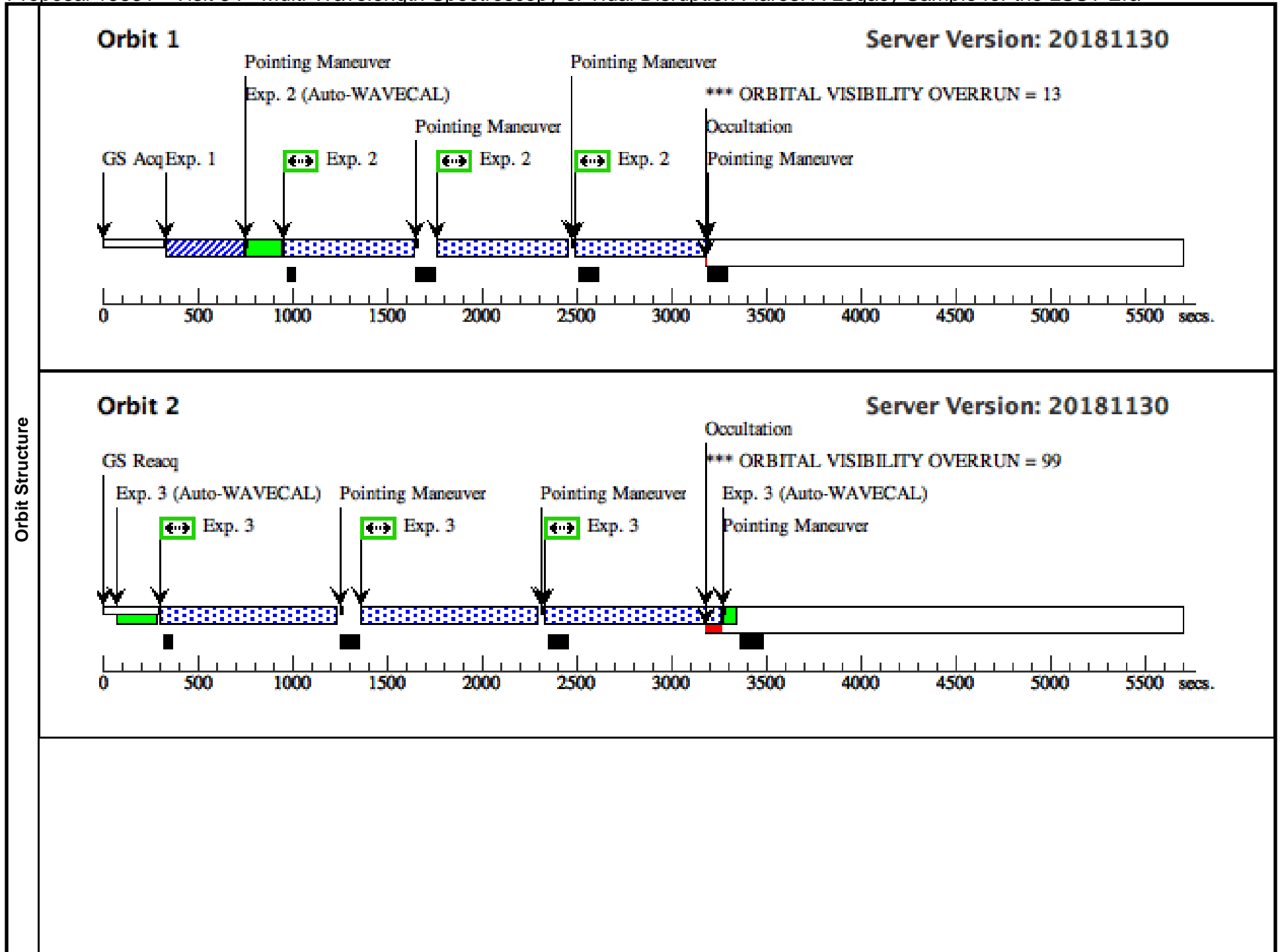

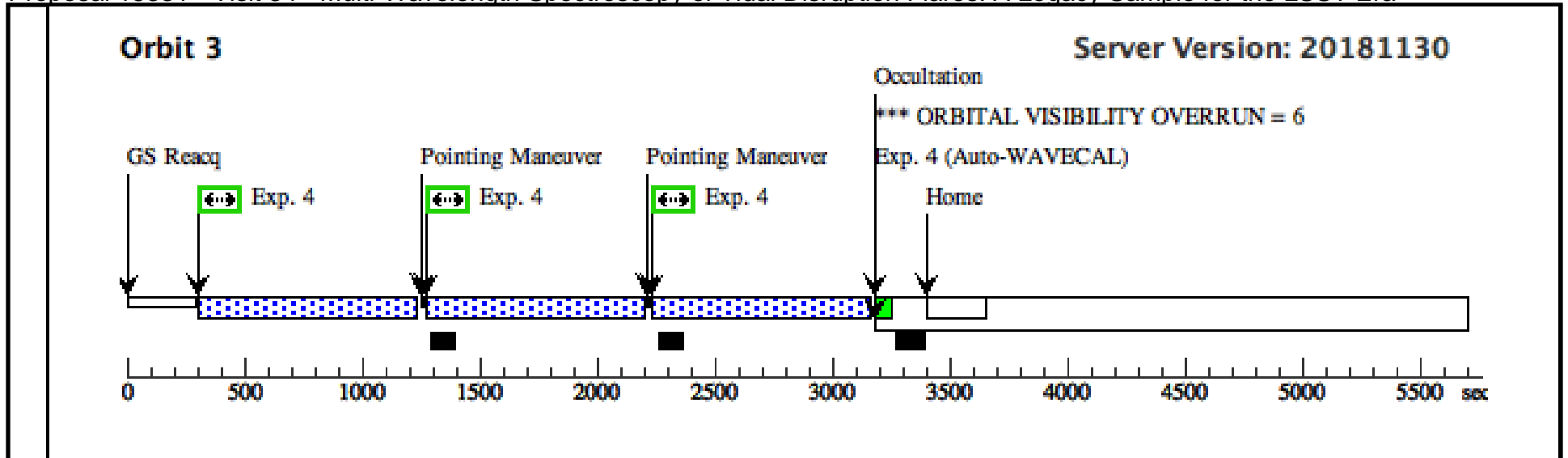

Proposal 15331 - Visit 35 - Multi-Wavelength Spectroscopy of Tidal Disruption Flares: A Legacy Sample for the LSST Era

Fri Jan 25 14:01:48 GMT 2019

Visit	Proposal 15331, Visit 35, completed Diagnostic Status: Warning Scientific Instruments: STIS/NUV-MAMA, STIS/CCD, STIS/FUV-MAMA Special Requirements: BETWEEN 20-MAY-2018:00:00:00 AND 27-MAY-2018:00:00:00										
	(Visit 35) Warning (Orbit Planner): ORBITAL VISIBILITY OVERRUN (Visit 35) Warning (Orbit Planner): ORBITAL VISIBILITY OVERRUN (Visit 35) Warning (Orbit Planner): ORBITAL VISIBILITY OVERRUN										
Diagnosics											
Patterns	#	Primary Pattern				Secondary Pattern				Exposures	
	(1)	Pattern Type=STIS-ALONG-SLIT		Coordinate Frame=POS-TARG						(2), (3), (4)	
		Purpose=DITHER		Pattern Orientation=90.0							
		Number Of Points=3		Angle Between Sides=							
		Point Spacing=0.4165		Center Pattern=false							
		Line Spacing=									
Fixed Targets	#	Name	Target Coordinates		Targ. Coord. Corrections		Fluxes		Miscellaneous		
	(6)	AT2018ZR	RA: 07 56 54.5489 (119.2272871d) Dec: +34 15 43.63 (34.26212d) Equinox: J2000				V=18.0		Reference Frame: ICRS		
		Comments: Category=GALAXY Description=[ACCRETION DISK]									
Exposures	#	Label (ETC Run)	Target	Config,Mode,Aperture	Spectral Els.	Opt. Params.	Special Reqs.	Groups	Exp. Time (Total)/[Actual Dur.]		Orbit
	1		(6) AT2018ZR	STIS/CCD, ACQ, F28X50LP	MIRROR				45 Secs (45 Secs)		
									[==>]		[1]
	2	(STIS.sp.11 56105)	(6) AT2018ZR	STIS/NUV-MAMA, ACCUM, 52X0.2	G230L 2376 A			Pattern 1, Exps 2-2 in Visit 35 (1)	674 Secs (2022 Secs)		
									[==>(Pattern 1)]		
									[==>(Pattern 2)]		[1]
								[==>(Pattern 3)]			
3	(STIS.sp.11 56106)	(6) AT2018ZR	STIS/FUV-MAMA, ACCUM, 52X0.2	G140L 1425 A			Pattern 1, Exps 3-3 in Visit 35 (1)	920 Secs (2760 Secs)			
								[==>(Pattern 1)]			
								[==>(Pattern 2)]		[2]	
								[==>(Pattern 3)]			
4	(STIS.sp.11 56106)	(6) AT2018ZR	STIS/FUV-MAMA, ACCUM, 52X0.2	G140L 1425 A			Pattern 1, Exps 4-4 in Visit 35 (1)	920 Secs (2760 Secs)			
								[==>(Pattern 1)]			
								[==>(Pattern 2)]		[3]	
								[==>(Pattern 3)]			

