



# 16252 - TREASUREHUNT: Hubble's UV-Visible treasury imaging of the JWST NEP Time-Domain Field

Cycle: 28, Proposal Category: GO

(Availability Mode: AVAILABLE)

## INVESTIGATORS

<i>Name</i>	<i>Institution</i>	<i>E-Mail</i>
<b>Dr. Rolf A. Jansen (PI) (Contact)</b>	<b>Arizona State University</b>	<b>rolf.jansen@asu.edu</b>
Dr. Norman Grogin (CoI) (Contact)	Space Telescope Science Institute	nagrogin@stsci.edu
Prof. Rogier A. Windhorst (CoI)	Arizona State University	rogier.windhorst@asu.edu
Dr. Christopher Nicholas Andrew Willmer (CoI)	University of Arizona	cnav@as.arizona.edu
Dr. Teresa Ann Ashcraft (CoI)	University of Tampa	tashcraft@ut.edu
Dr. Silvia Bonoli (CoI) (ESA Member)	Donostia International Physics Center	silvia.bonoli@dipc.org
Dr. Walter Brisken (CoI)	Associated Universities, Inc.	wbrisken@nrao.edu
Dr. Seth H. Cohen (CoI)	Arizona State University	seth.cohen@asu.edu
Prof. Christopher Conselice (CoI) (ESA Member)	University of Manchester	conselice@gmail.com
Dr. William Cotton (CoI)	Associated Universities, Inc.	bcotton@nrao.edu
Prof. Vik Dhillon (CoI) (ESA Member)	University of Sheffield	vik.dhillon@sheffield.ac.uk
Prof. Simon P. Driver (CoI)	University of Western Australia	simon.driver@icrar.org
Dr. Kenneth James Duncan (CoI) (ESA Member)	University of Edinburgh, Institute for Astronomy	kdun@roe.ac.uk
Dr. Renato A. Dupke (CoI)	Eureka Scientific Inc.	rdupke@umich.edu
Prof. Steven L. Finkelstein (CoI)	University of Texas at Austin	stevenf@astro.as.utexas.edu
Prof. Brenda Louise Frye (CoI)	University of Arizona	bfrye@arizona.edu
Mr. Alex Griffiths (CoI) (ESA Member)	University of Nottingham	alex.griffiths@nottingham.ac.uk
Dr. Nimish P. Hathi (CoI)	Space Telescope Science Institute	nhathi@stsci.edu
Ms. Victoria R Jones (CoI)	University of Arizona	vrjones@email.arizona.edu
Dr. Duho Kim (CoI)	Korea Astronomy and Space Science Institute (KASI)	dhkim@kasi.re.kr

Proposal 16252 (STScI Edit Number: 28, Created: Tuesday, October 25, 2022 at 2:01:01 PM Eastern Standard Time) - Overview

<i>Name</i>	<i>Institution</i>	<i>E-Mail</i>
Dr. Anton M. Koekemoer (CoI)	Space Telescope Science Institute	koekemoer@stsci.edu
Ms. Rebecca L. Larson (CoI)	University of Texas at Austin	rlarson@astro.as.utexas.edu
Dr. Walter Peter Maksym III (CoI)	Smithsonian Institution Astrophysical Observatory	peter.maksym@gmail.com
Dr. Madeline Marshall (CoI) (CSA Member)	Dominion Astrophysical Observatory	madeline_marshall@outlook.com
Dr. Hugo Messias (CoI) (ESA Member)	European Southern Observatory - Chile	hugo.messias@alma.cl
Dr. Stefanie N. Milam (CoI)	NASA Goddard Space Flight Center	stefanie.n.milam@nasa.gov
Dr. Richard A. Perley (CoI)	Associated Universities, Inc.	rperley@nrao.edu
Dr. Justin Pierel (CoI)	Space Telescope Science Institute	jpierel@stsci.edu
Dr. Steve Rodney (CoI)	University of South Carolina	steve.rodney@gmail.com
Dr. Michael James Rutkowski (CoI)	Minnesota State University, Mankato	michael.rutkowski@mnsu.edu
Dr. Russell E. Ryan Jr. (CoI)	Space Telescope Science Institute	rryan@stsci.edu
Prof. Ian Smail (CoI) (ESA Member)	Durham Univ.	ian.smail@durham.ac.uk
Dr. Brent Matthew Smith (CoI)	Arizona State University	brent.smith.1@asu.edu
Mr. Cameron W. White (CoI)	University of Arizona	cwwhite@email.arizona.edu
Dr. Nico Cappelluti (CoI)	University of Miami	nicocappelluti@gmail.com
Prof. Myungshin Im (CoI)	Seoul National University	myungshin.im@gmail.com
Dr. Mehmet Alpaslan (CoI)	New York University	mehmet.alpaslan@nyu.edu
Prof. Huub Rottgering (CoI) (ESA Member)	Universiteit Leiden	rottgering@strw.leidenuniv.nl
Dr. Matthew L. N. Ashby (CoI)	Smithsonian Institution Astrophysical Observatory	mashby@cfa.harvard.edu
Dr. Giovanni G. Fazio (CoI)	Smithsonian Institution Astrophysical Observatory	gfazio@cfa.harvard.edu
Prof. Martin J. Ward (CoI) (ESA Member)	Durham Univ.	martin.ward@durham.ac.uk
Dr. Heidi B. Hammel (CoI)	Space Science Institute	hbhammel@aura-astronomy.org
Dr. Martin Elvis (CoI)	Smithsonian Institution Astrophysical Observatory	elvis@cfa.harvard.edu
Dr. Francesca Civano (CoI)	Smithsonian Institution Astrophysical Observatory	fcivano@cfa.harvard.edu
Dr. Bilal Ladjelate (CoI) (ESA Member)	Institut De Radioastronomie Millimetrique (IRAM)	ladjelate@iram.es
Dr. Sangeeta Malhotra (CoI)	NASA Goddard Space Flight Center	sangeeta.malhotra@nasa.gov
Dr. Reinout Johannes van Weeren (CoI) (ESA Member)	Universiteit Leiden	rvweeren@strw.leidenuniv.nl
Dr. James Rhoads (CoI)	NASA Goddard Space Flight Center	james.e.rhoads@nasa.gov
Dr. Minhee Hyun (CoI)	Seoul National University	minhee@astro.snu.ac.kr

**VISITS**

<i>Visit</i>	<i>Targets used in Visit</i>	<i>Configurations used in Visit</i>	<i>Orbits Used</i>	<i>Last Orbit Planner Run</i>	<i>OP Current with Visit?</i>
01	(2) JWST-NEP-TDF-01WFC ANY	ACS/WFC WFC3/UVIS	5	25-Oct-2022 15:00:30.0	yes
02	(1) JWST-NEP-TDF ANY	ACS/WFC WFC3/UVIS	5	25-Oct-2022 15:00:33.0	yes
03	(1) JWST-NEP-TDF ANY	ACS/WFC WFC3/UVIS	5	25-Oct-2022 15:00:37.0	yes
04	(1) JWST-NEP-TDF ANY	ACS/WFC WFC3/UVIS	4	25-Oct-2022 15:00:40.0	yes
A4	(1) JWST-NEP-TDF	ACS/WFC	5	25-Oct-2022 15:00:43.0	yes
05	(1) JWST-NEP-TDF ANY	ACS/WFC WFC3/UVIS	5	25-Oct-2022 15:00:46.0	yes
6A	(5) JWST-NEP-TDF-6AWFC ANY	ACS/WFC WFC3/UVIS	5	25-Oct-2022 15:00:49.0	yes
6B	(4) JWST-NEP-TDF-6BUVIS ANY	ACS/WFC WFC3/UVIS	5	25-Oct-2022 15:00:53.0	yes
07	(1) JWST-NEP-TDF ANY	ACS/WFC WFC3/UVIS	5	25-Oct-2022 15:00:56.0	yes
08	(3) JWST-NEP-TDF-1BUVIS ANY	ACS/WFC WFC3/UVIS	5	25-Oct-2022 15:01:00.0	yes

49 Total Orbits Used

**ABSTRACT**

We propose to complete the near-contiguous UV-Visible imaging of the JWST NEP Time-Domain Field, the best field within the JWST Continuous Viewing Zones to conduct deep and wide extragalactic JWST surveys at arbitrary cadence or orientation. This recently developed, ~14' diameter time-domain field near the North Ecliptic Pole (1) is devoid of sources brighter than  $m_{AB} \sim 16$  mag at 2-4 micron that would deeply saturate JWST/NIRCam, (2) has the lowest possible zodiacal foreground, (3) has low Galactic foreground extinction, and (4) has a wealth of deep ground- and space-based ancillary data from X-ray through radio. Deep UV-Visible HST imaging to  $m_{AB} \sim 28$  mag exists for the inner ~9' diameter portion

Proposal 16252 (STScI Edit Number: 28, Created: Tuesday, October 25, 2022 at 2:01:01 PM Eastern Standard Time) - Overview of this field. Completing the coverage of the NEP Time-Domain Field to the same depth, in combination with extant data, allows the community to:

- (1) Establish a baseline UV-Visible detection image at  $\sim 0.07''$  FWHM at wavelengths inaccessible to JWST, and map transients and moving objects in areas of 2- and 3-epoch overlap;
- (2) Identify rest-frame UV-bright objects at  $z < 6$  that would contaminate JWST ultra-high- $z$  galaxy samples;
- (3) Identify galaxies with steep intrinsic UV-Visible SEDs indicative of (weak)AGN, assess the escape of LyC photons at  $2 < z < 3$ , and place limits on that escape and IGM porosity at  $z < \sim 3.5$ ; and
- (4) Study mass assembly and evolution of all significantly resolved UV-bright galaxies at  $z < 6$  on a 'pixel-by-pixel' basis.

In order to maximize the scientific return of early-release JWST science, it is critical to image this field in the UV-Visible while HST is still in its prime and before commencement of JWST observations in Fall 2021.

## **OBSERVING DESCRIPTION**

This treasury program was allocated 28 primary plus 28 parallel orbits in Cycle 28, and 24 primary plus 24 parallel orbits in Cycle 29, and aims to complete near-contiguous 3-filter UV--visible HST imaging of the JWST North Ecliptic Pole (NEP) Time-Domain Field, for which allocated GTO observations will provide both NIRCам 8-band imaging and NIRISS slitless spectroscopy at four distinct "spokes". JWST ERS and GO observers will have access to the GTO data, so we anticipate time-domain follow-up as early as JWST Cycle 1, as well as additional areal coverage within this field. The JWST NEP Time-Domain Field was defined to be the cleanest  $\sim 14'$  diameter area in JWST's northern Continuous Viewing Zone (CVZ), where JWST can conduct a deep extragalactic time-domain survey, with added utility for extreme outer solar system and near-Galactic time-domain science. The present program, GO-16252, builds directly on Cycle 25 program GO-15278, which covered the inner  $\sim 5'$  diameter portion of the field, by imaging an annulus surrounding the extant observations to very similar depths. We aim to minimize both gaps between new and extant data, and overlap with those extant data, while maximizing use of (pseudo)CVZ opportunities in Cycle 28 and 29. To maximize (1) overall HST coverage of the JWST NEP Time-Domain Field, (2) overlap of the UV coverage of WFC3/UVIS F275W and visible coverage of ACS/WFC F435W and F606W, and (3) execute this program as efficiently as possible, we specify seven (Cycle 28) + six (Cycle 29) 4-orbit visits using (pseudo)CVZ orbits with orientations and POS TARG offsets such that WFC3/UVIS F275W observations at one orientation will largely overlap ACS/WFC F435W and F606W observations at an alternate orientation in our overall pattern. This observational design brings our program to the total of 52 primary and 52 coordinated parallel orbits approved in Phase I. Through experimentation in Cycle 25 Phase II, we found that the visits optimize better when we define the ACS/WFC observations as primary and the WFC3/UVIS observations as coordinated parallels. This does not change the intent or scope of this program. The final detailed layout takes into account the availability of suitable guide stars for each visit, which forced a slight offset of  $\sim 30''$  of

Proposal 16252 (STScI Edit Number: 28, Created: Tuesday, October 25, 2022 at 2:01:01 PM Eastern Standard Time) - Overview  
visit #1 with respect to the ideal pointing. While we designed the detailed observations for the full Cycle 28+29 program, the Phase-II APT of GO-16252 covers only Cycle 28, i.e., the first 7 out of 13 visits.

Proposal 16252 - treasurehunt-epoch01of13 (01) - TREASUREHUNT: Hubble's UV-Visible treasury imaging of the JWST NEP Time-...

Tue Oct 25 19:01:01 GMT 2022

<b>Visit</b>	<p><b>Proposal 16252, treasurehunt-epoch01of13 (01), failed</b></p> <p><b>Diagnostic Status: Error</b></p> <p>Scientific Instruments: WFC3/UVIS, ACS/WFC</p> <p>Special Requirements: BRIGHT EARTH AVOID 13.5D; ORIENT 078.9D TO 078.9 D; BETWEEN 2020.268:05:06:39 AND 2020.268:05:12:39; BETWEEN 2020.269:04:56:40 AND 2020.269:05:02:40; BETWEEN 2020.270:04:46:49 AND 2020.270:04:52:49; BETWEEN 2020.271:04:36:36 AND 2020.271:04:42:36; VISIBILITY INTERVAL 5714 S</p> <p><i>Comments: Epoch 01 of 13 is a 4-orbit (pseudo)CVZ visit, using the opportunity at ORIENT = 081.9 degrees. After guide star acquisition at the start of the first orbit, the guide star remains visible and locked for the duration of the visit, so no guide star re-acquisition in subsequent orbits will be required in orbits 2--4. This strategy is the same as adopted for GO-15278 in Cycle 25, and as successfully executed through Cycle 27. An additional pre-pattern exposure has been added for OBAD follow-on needs. Custom targeting (modulated by small dither POSTARs) has been implemented for this visit, because of severe guidestar paucity at the intended location within the 13-epoch pattern. While APT throws an error for the specified Bright Earth Avoidance angle of 13.5 degrees, this value is intended and proven to schedule for a pseudo-CVZ visit.</i></p>					
	<p>(treasurehunt-epoch01of13 (01)) Error (Form): The specified Bright Earth Avoidance angle is outside the permitted range.</p> <p>(treasurehunt-epoch01of13 (01)) Warning (Orbit Planner): NO VISIBILITY TABLE CORRESPONDING TO BRIGHT EARTH AVOIDANCE ANGLE</p> <p>(treasurehunt-epoch01of13 (01)) Warning (Orbit Planner): ORBITAL VISIBILITY OVERRUN</p> <p>(treasurehunt-epoch01of13 (01)) Warning (Orbit Planner): ORBITAL VISIBILITY OVERRUN</p> <p>(treasurehunt-epoch01of13 (01)) Warning (Orbit Planner): ORBITAL VISIBILITY OVERRUN</p> <p>(treasurehunt-epoch01of13 (01)) Warning (Orbit Planner): PARALLELS SIGNIFICANTLY EXTEND ALIGNMENT TIME</p>					
<b>Diagnosics</b>						
<b>Fixed Targets</b>	<b>#</b>	<b>Name</b>	<b>Target Coordinates</b>	<b>Targ. Coord. Corrections</b>	<b>Fluxes</b>	<b>Miscellaneous</b>
	(2)	JWST-NEP-TDF-01WFC Alt Name1: WTDF	RA: 17 21 54.7253 (260.4780221d) Dec: +65 49 7.46 (65.81874d) Equinox: J2000		V=27.0+/-1.0	Reference Frame: ICRS
<p><i>Comments: The target field is centered on the extant HST observations of the JWST NEP Time-Domain Field of GO-15278. Allocated JWST GTO observations will provide both NIRCcam imaging and NIRISS slitless spectroscopy in this field, which was defined to be the cleanest ~14' diameter area in JWST's northern continuous viewing zone, where JWST will conduct a deep extragalactic time-domain survey, with added utility for extreme outer solar system and near-Galactic time-domain science. The JWST NEP Time-Domain Field is developed as a *community field*, and has deep coverage accross the electromagnetic spectrum from X-ray through long-wave radio. The present HST program will complete near-contiguous 3-filter coverage in the UV--Visible, targeting the annulus surrounding the extant HST observations of GO-15278.</i></p> <p>Category=UNIDENTIFIED</p> <p>Description=[HIGH LATITUDE FIELD, INFRARED EMITTER, OPTICAL EMITTER, ULTRAVIOLET EMITTER]</p>						

Proposal 16252 - treasurehunt-epoch01of13 (01) - TREASUREHUNT: Hubble's UV-Visible treasury imaging of the JWST NEP Time...

#	Label (ETC Run)	Target	Config,Mode,Aperture	Spectral Els.	Opt. Params.	Special Reqs.	Groups	Exp. Time (Total)/[Actual Dur.]	Orbit
1		(2) JWST-NEP-TDF -01WFC	ACS/WFC, ACCUM, WFCENTER	F435W		POS TARG -0.1,+0.1; GS ACQ SCENARIO BASE1BE	Sequence 1-26 Non-Int in treasurehunt-epoch01of13 (01)  Prime + Parallel Group 1-2 in Sequence 1-26 Non-Int in treasurehunt-epoch01of13 (01)	800 Secs (800 Secs) [==>]	[1]
<p><i>Comments: The specified POS_TARG values intentionally place the WFC3/UVIS and ACS/WFC instrument apertures off the coordinates of the target (i.e., the center of the JWST NEP Time-Domain Field) to their intended locations within an annulus surrounding the extant HST data.</i></p>									
2	(WFC3UVIS.im.1445613)	ANY	WFC3/UVIS, ACCUM, UVIS	F275W	FLASH=17		Sequence 1-26 Non-Int in treasurehunt-epoch01of13 (01)  Prime + Parallel Group 1-2 in Sequence 1-26 Non-Int in treasurehunt-epoch01of13 (01)	851 Secs (851 Secs) [==>]	[1]
<p><i>Comments: Following the June 4 2020 recommendations of J. Anderson (2020) "CURRENT CTE-MITIGATION RECOMMENDATIONS", we aim for a minimum background level of 20 e-/pix in each WFC3/UVIS F275W exposure. Taking into account the raised natural background of this pseudo-CVZ visit, the WFC3/UVIS ETC shows that this requirement becomes satisfied for FLASH=11. The APT Phase-II diagnostics seem to still test the older (now superseded) recommendation of a minimum of only 12 e-/pix, and therefore result in a warning that the specified postflash may be too high.</i></p>									
3		(2) JWST-NEP-TDF -01WFC	ACS/WFC, ACCUM, WFCENTER	F435W		POS TARG -0.1,+0.1	Sequence 1-26 Non-Int in treasurehunt-epoch01of13 (01)  Prime + Parallel Group 3-5 in Sequence 1-26 Non-Int in treasurehunt-epoch01of13 (01)	1136 Secs (1136 Secs) [==>]	[1]
<p><i>Comments: The specified POS_TARG values intentionally place the WFC3/UVIS and ACS/WFC instrument apertures off the coordinates of the target (i.e., the center of the JWST NEP Time-Domain Field) to their intended locations within an annulus surrounding the extant HST data.</i></p>									
4		(2) JWST-NEP-TDF -01WFC	ACS/WFC, ACCUM, WFCENTER	F606W		POS TARG -0.1,+0.1	Sequence 1-26 Non-Int in treasurehunt-epoch01of13 (01)  Prime + Parallel Group 3-5 in Sequence 1-26 Non-Int in treasurehunt-epoch01of13 (01)	1136 Secs (1136 Secs) [==>]	[1]
5	(WFC3UVIS.im.1445613)	ANY	WFC3/UVIS, ACCUM, UVIS	F275W	FLASH=11		Sequence 1-26 Non-Int in treasurehunt-epoch01of13 (01)  Prime + Parallel Group 3-5 in Sequence 1-26 Non-Int in treasurehunt-epoch01of13 (01)	2544 Secs (2544 Secs) [==>]	[1]
<p><i>Comments: Following the June 4 2020 recommendations of J. Anderson (2020) "CURRENT CTE-MITIGATION RECOMMENDATIONS", we aim for a minimum background level of 20 e-/pix in each WFC3/UVIS F275W exposure. Taking into account the raised natural background of this pseudo-CVZ visit, the WFC3/UVIS ETC shows that this requirement becomes satisfied for FLASH=11. The APT Phase-II diagnostics seem to still test the older (now superseded) recommendation of a minimum of only 12 e-/pix, and therefore result in a warning that the specified postflash may be too high.</i></p>									

Proposal 16252 - treasurehunt-epoch01of13 (01) - TREASUREHUNT: Hubble's UV-Visible treasury imaging of the JWST NEP Time-...

6	(2) JWST-NEP-TDF -01WFC	ACS/WFC, ACCUM, WFCENTER	F606W			POS TARG +0.1,+0.1	Sequence 1-26 Non-Int in treasurehunt-epoch01of13 (01)  Prime + Parallel Group 6-8 in Sequence 1-26 Non-Int in treasurehunt-epoch01of13 (01)	1140 Secs (1140 Secs)  [==>]	[1]
<p>Comments: The specified POS_TARG values intentionally place the WFC3/UVIS and ACS/WFC instrument apertures off the coordinates of the target (i.e., the center of the JWST NEP Time-Domain Field) to their intended locations within an annulus surrounding the extant HST data.</p>									
7	(2) JWST-NEP-TDF -01WFC	ACS/WFC, ACCUM, WFCENTER	F435W			POS TARG +0.1,+0.1	Sequence 1-26 Non-Int in treasurehunt-epoch01of13 (01)  Prime + Parallel Group 6-8 in Sequence 1-26 Non-Int in treasurehunt-epoch01of13 (01)	1140 Secs (1140 Secs)  [==>]	[1]
8	(WFC3UVI ANY S.im.144561 3)	WFC3/UVIS, ACCUM, UVIS	F275W	FLASH=11			Sequence 1-26 Non-Int in treasurehunt-epoch01of13 (01)  Prime + Parallel Group 6-8 in Sequence 1-26 Non-Int in treasurehunt-epoch01of13 (01)	2504 Secs (2504 Secs)  [==>]	[1]
<p>Comments: Following the June 4 2020 recommendations of J. Anderson (2020) "CURRENT CTE-MITIGATION RECOMMENDATIONS", we aim for a minimum background level of 20 e-/pix in each WFC3/UVIS F275W exposure. Taking into account the raised natural background of this pseudo-CVZ visit, the WFC3/UVIS ETC shows that this requirement becomes satisfied for FLASH=11. The APT Phase-II diagnostics seem to still test the older (now superseded) recommendation of a minimum of only 12 e-/pix, and therefore result in a warning that the specified postflash may be too high.</p>									
9	(2) JWST-NEP-TDF -01WFC	ACS/WFC, ACCUM, WFCENTER	F435W			POS TARG -0.1,-0.1	Sequence 1-26 Non-Int in treasurehunt-epoch01of13 (01)  Prime + Parallel Group 9-11 in Sequence 1-26 Non-Int in treasurehunt-epoch01of13 (01)	1245 Secs (1245 Secs)  [==>]	[2]
<p>Comments: The specified POS_TARG values intentionally place the WFC3/UVIS and ACS/WFC instrument apertures off the coordinates of the target (i.e., the center of the JWST NEP Time-Domain Field) to their intended locations within an annulus surrounding the extant HST data.</p>									
10	(2) JWST-NEP-TDF -01WFC	ACS/WFC, ACCUM, WFCENTER	F606W			POS TARG -0.1,-0.1	Sequence 1-26 Non-Int in treasurehunt-epoch01of13 (01)  Prime + Parallel Group 9-11 in Sequence 1-26 Non-Int in treasurehunt-epoch01of13 (01)	1245 Secs (1245 Secs)  [==>]	[2]
11	(WFC3UVI ANY S.im.144561 3)	WFC3/UVIS, ACCUM, UVIS	F275W	FLASH=11			Sequence 1-26 Non-Int in treasurehunt-epoch01of13 (01)  Prime + Parallel Group 9-11 in Sequence 1-26 Non-Int in treasurehunt-epoch01of13 (01)	2714 Secs (2714 Secs)  [==>]	[2]
<p>Comments: Following the June 4 2020 recommendations of J. Anderson (2020) "CURRENT CTE-MITIGATION RECOMMENDATIONS", we aim for a minimum background level of 20 e-/pix in each WFC3/UVIS F275W exposure. Taking into account the raised natural background of this pseudo-CVZ visit, the WFC3/UVIS ETC shows that this requirement becomes satisfied for FLASH=11. The APT Phase-II diagnostics seem to still test the older (now superseded) recommendation of a minimum of only 12 e-/pix, and therefore result in a warning that the specified postflash may be too high.</p>									

Proposal 16252 - treasurehunt-epoch01of13 (01) - TREASUREHUNT: Hubble's UV-Visible treasury imaging of the JWST NEP Time...

12	(2) JWST-NEP-TDF -01WFC	ACS/WFC, ACCUM, WFCENTER	F606W			POS TARG +0.1,-0.1	Sequence 1-26 Non-Int in treasurehunt-epoch01of13 (01)  Prime + Parallel Group 12-14 in Sequence 1-26 Non-Int in treasurehunt-epoch01of13 (01)	1253 Secs (1253 Secs)  [==>]	[2]
<p>Comments: The specified POS_TARG values intentionally place the WFC3/UVIS and ACS/WFC instrument apertures off the coordinates of the target (i.e., the center of the JWST NEP Time-Domain Field) to their intended locations within an annulus surrounding the extant HST data.</p>									
13	(2) JWST-NEP-TDF -01WFC	ACS/WFC, ACCUM, WFCENTER	F435W			POS TARG +0.1,-0.1	Sequence 1-26 Non-Int in treasurehunt-epoch01of13 (01)  Prime + Parallel Group 12-14 in Sequence 1-26 Non-Int in treasurehunt-epoch01of13 (01)	1254 Secs (1254 Secs)  [==>]	[2]
14	(WFC3UVI ANY S.im.144561 3)	WFC3/UVIS, ACCUM, UVIS	F275W	FLASH=11			Sequence 1-26 Non-Int in treasurehunt-epoch01of13 (01)  Prime + Parallel Group 12-14 in Sequence 1-26 Non-Int in treasurehunt-epoch01of13 (01)	2731 Secs (2731 Secs)  [==>]	[2]
<p>Comments: Following the June 4 2020 recommendations of J. Anderson (2020) "CURRENT CTE-MITIGATION RECOMMENDATIONS", we aim for a minimum background level of 20 e-/pix in each WFC3/UVIS F275W exposure. Taking into account the raised natural background of this pseudo-CVZ visit, the WFC3/UVIS ETC shows that this requirement becomes satisfied for FLASH=11. The APT Phase-II diagnostics seem to still test the older (now superseded) recommendation of a minimum of only 12 e-/pix, and therefore result in a warning that the specified postflash may be too high.</p>									
15	(2) JWST-NEP-TDF -01WFC	ACS/WFC, ACCUM, WFCENTER	F435W			POS TARG -0.2,+0.2	Sequence 1-26 Non-Int in treasurehunt-epoch01of13 (01)  Prime + Parallel Group 15-17 in Sequence 1-26 Non-Int in treasurehunt-epoch01of13 (01)	1245 Secs (1245 Secs)  [==>]	[3]
<p>Comments: The specified POS_TARG values intentionally place the WFC3/UVIS and ACS/WFC instrument apertures off the coordinates of the target (i.e., the center of the JWST NEP Time-Domain Field) to their intended locations within an annulus surrounding the extant HST data.</p>									
16	(2) JWST-NEP-TDF -01WFC	ACS/WFC, ACCUM, WFCENTER	F606W			POS TARG -0.2,+0.2	Sequence 1-26 Non-Int in treasurehunt-epoch01of13 (01)  Prime + Parallel Group 15-17 in Sequence 1-26 Non-Int in treasurehunt-epoch01of13 (01)	1245 Secs (1245 Secs)  [==>]	[3]
17	(WFC3UVI ANY S.im.144561 3)	WFC3/UVIS, ACCUM, UVIS	F275W	FLASH=11			Sequence 1-26 Non-Int in treasurehunt-epoch01of13 (01)  Prime + Parallel Group 15-17 in Sequence 1-26 Non-Int in treasurehunt-epoch01of13 (01)	2714 Secs (2714 Secs)  [==>]	[3]
<p>Comments: Following the June 4 2020 recommendations of J. Anderson (2020) "CURRENT CTE-MITIGATION RECOMMENDATIONS", we aim for a minimum background level of 20 e-/pix in each WFC3/UVIS F275W exposure. Taking into account the raised natural background of this pseudo-CVZ visit, the WFC3/UVIS ETC shows that this requirement becomes satisfied for FLASH=11. The APT Phase-II diagnostics seem to still test the older (now superseded) recommendation of a minimum of only 12 e-/pix, and therefore result in a warning that the specified postflash may be too high.</p>									

Proposal 16252 - treasurehunt-epoch01of13 (01) - TREASUREHUNT: Hubble's UV-Visible treasury imaging of the JWST NEP Time-...

18	(2) JWST-NEP-TDF -01WFC	ACS/WFC, ACCUM, WFCENTER	F606W			POS TARG +0.0,+0.2	Sequence 1-26 Non-Int in treasurehunt-epoch01of13 (01)  Prime + Parallel Group 18-20 in Sequence 1-26 Non-Int in treasurehunt-epoch01of13 (01)	1253 Secs (1253 Secs)  [==>]	[3]
<p>Comments: The specified POS_TARG values intentionally place the WFC3/UVIS and ACS/WFC instrument apertures off the coordinates of the target (i.e., the center of the JWST NEP Time-Domain Field) to their intended locations within an annulus surrounding the extant HST data.</p>									
19	(2) JWST-NEP-TDF -01WFC	ACS/WFC, ACCUM, WFCENTER	F435W			POS TARG +0.0,+0.2	Sequence 1-26 Non-Int in treasurehunt-epoch01of13 (01)  Prime + Parallel Group 18-20 in Sequence 1-26 Non-Int in treasurehunt-epoch01of13 (01)	1254 Secs (1254 Secs)  [==>]	[3]
20	(WFC3UVI ANY S.im.144561 3)	WFC3/UVIS, ACCUM, UVIS	F275W	FLASH=11			Sequence 1-26 Non-Int in treasurehunt-epoch01of13 (01)  Prime + Parallel Group 18-20 in Sequence 1-26 Non-Int in treasurehunt-epoch01of13 (01)	2731 Secs (2731 Secs)  [==>]	[3]
<p>Comments: Following the June 4 2020 recommendations of J. Anderson (2020) "CURRENT CTE-MITIGATION RECOMMENDATIONS", we aim for a minimum background level of 20 e-/pix in each WFC3/UVIS F275W exposure. Taking into account the raised natural background of this pseudo-CVZ visit, the WFC3/UVIS ETC shows that this requirement becomes satisfied for FLASH=11. The APT Phase-II diagnostics seem to still test the older (now superseded) recommendation of a minimum of only 12 e-/pix, and therefore result in a warning that the specified postflash may be too high.</p>									
21	(2) JWST-NEP-TDF -01WFC	ACS/WFC, ACCUM, WFCENTER	F435W			POS TARG -0.2,+0.0	Sequence 1-26 Non-Int in treasurehunt-epoch01of13 (01)  Prime + Parallel Group 21-23 in Sequence 1-26 Non-Int in treasurehunt-epoch01of13 (01)	994 Secs (994 Secs)  [==>]	[4]
<p>Comments: The specified POS_TARG values intentionally place the WFC3/UVIS and ACS/WFC instrument apertures off the coordinates of the target (i.e., the center of the JWST NEP Time-Domain Field) to their intended locations within an annulus surrounding the extant HST data.</p>									
22	(2) JWST-NEP-TDF -01WFC	ACS/WFC, ACCUM, WFCENTER	F606W			POS TARG -0.2,+0.0	Sequence 1-26 Non-Int in treasurehunt-epoch01of13 (01)  Prime + Parallel Group 21-23 in Sequence 1-26 Non-Int in treasurehunt-epoch01of13 (01)	994 Secs (994 Secs)  [==>]	[4]
23	(WFC3UVI ANY S.im.144564 4)	WFC3/UVIS, ACCUM, UVIS	F275W	FLASH=12			Sequence 1-26 Non-Int in treasurehunt-epoch01of13 (01)  Prime + Parallel Group 21-23 in Sequence 1-26 Non-Int in treasurehunt-epoch01of13 (01)	2212 Secs (2212 Secs)  [==>]	[4]
<p>Comments: Following the June 4 2020 recommendations of J. Anderson (2020) "CURRENT CTE-MITIGATION RECOMMENDATIONS", we aim for a minimum background level of 20 e-/pix in each WFC3/UVIS F275W exposure. Taking into account the raised natural background of this pseudo-CVZ visit, the WFC3/UVIS ETC shows that this requirement becomes satisfied for FLASH=12. The APT Phase-II diagnostics seem to still test the older (now superseded) recommendation of a minimum of only 12 e-/pix, and therefore result in a warning that the specified postflash may be too high.</p>									

Proposal 16252 - treasurehunt-epoch01of13 (01) - TREASUREHUNT: Hubble's UV-Visible treasury imaging of the JWST NEP Time-...

24	(2) JWST-NEP-TDF -01WFC	ACS/WFC, ACCUM, WFCENTER	F606W		POS TARG +0.0,+0.0	Sequence 1-26 Non-Int in treasurehunt-epoch01of13 (01)  Prime + Parallel Group 24-26 in Sequence 1-26 Non-Int in treasurehunt-epoch01of13 (01)	997 Secs (997 Secs) [==>]	[4]
<p><i>Comments: The specified POS_TARG values intentionally place the WFC3/UVIS and ACS/WFC instrument apertures off the coordinates of the target (i.e., the center of the JWST NEP Time-Domain Field) to their intended locations within an annulus surrounding the extant HST data.</i></p>								
25	(2) JWST-NEP-TDF -01WFC	ACS/WFC, ACCUM, WFCENTER	F435W		POS TARG +0.0,+0.0	Sequence 1-26 Non-Int in treasurehunt-epoch01of13 (01)  Prime + Parallel Group 24-26 in Sequence 1-26 Non-Int in treasurehunt-epoch01of13 (01)	997 Secs (997 Secs) [==>]	[4]
26	(WFC3UVI ANY S.im.144564 4)	WFC3/UVIS, ACCUM, UVIS	F275W	FLASH=12		Sequence 1-26 Non-Int in treasurehunt-epoch01of13 (01)  Prime + Parallel Group 24-26 in Sequence 1-26 Non-Int in treasurehunt-epoch01of13 (01)	2198 Secs (2198 Secs) [==>]	[4]
<p><i>Comments: Following the June 4 2020 recommendations of J. Anderson (2020) "CURRENT CTE-MITIGATION RECOMMENDATIONS", we aim for a minimum background level of 20 e-/pix in each WFC3/UVIS F275W exposure. Taking into account the raised natural background of this pseudo-CVZ visit, the WFC3/UVIS ETC shows that this requirement becomes satisfied for FLASH=12. The APT Phase-II diagnostics seem to still test the older (now superseded) recommendation of a minimum of only 12 e-/pix, and therefore result in a warning that the specified postflash may be too high.</i></p>								

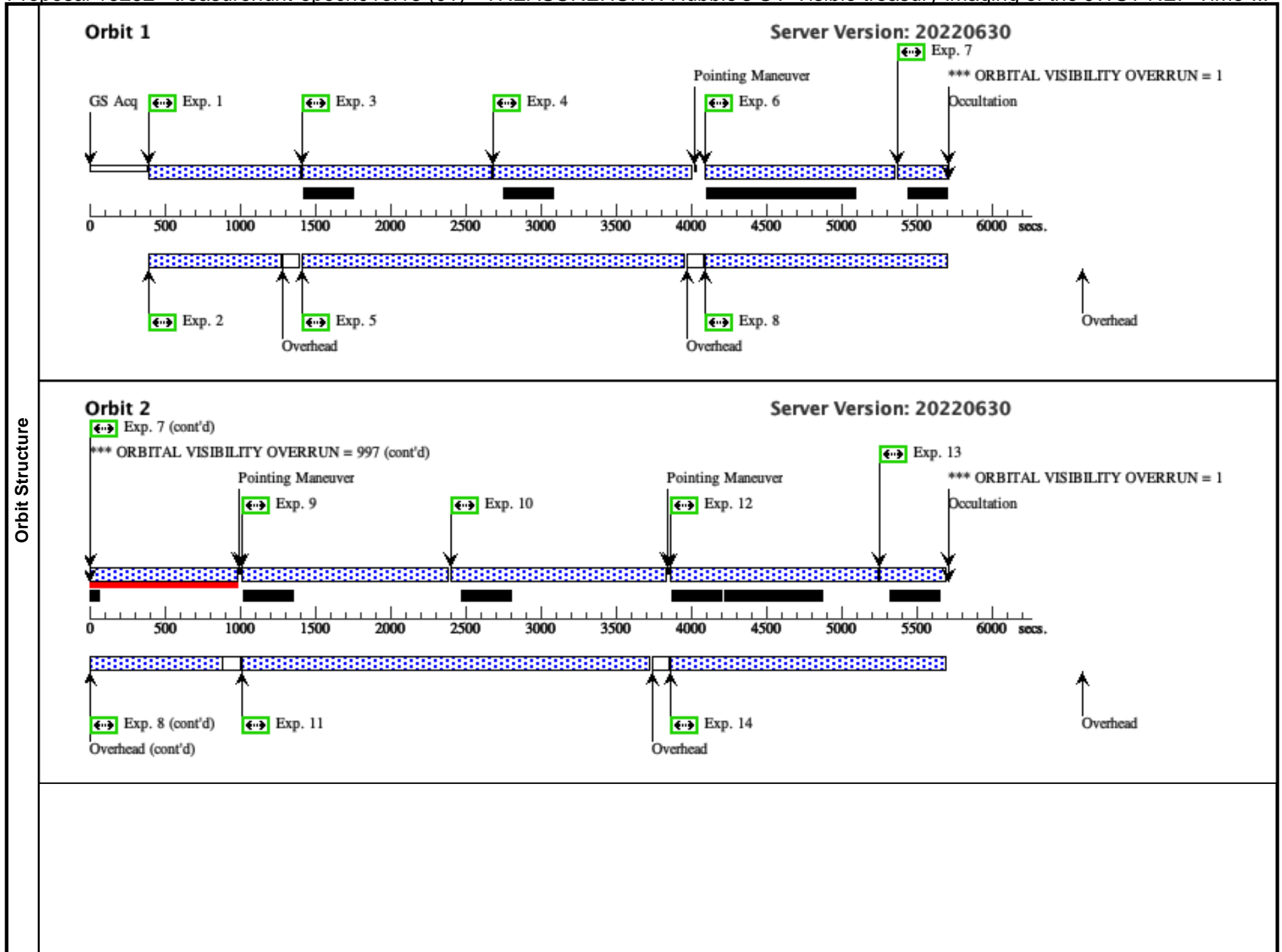

**Orbit 3**

Server Version: 20220630

\*\*\* ORBITAL VISIBILITY OVERRUN = 997 (cont'd)

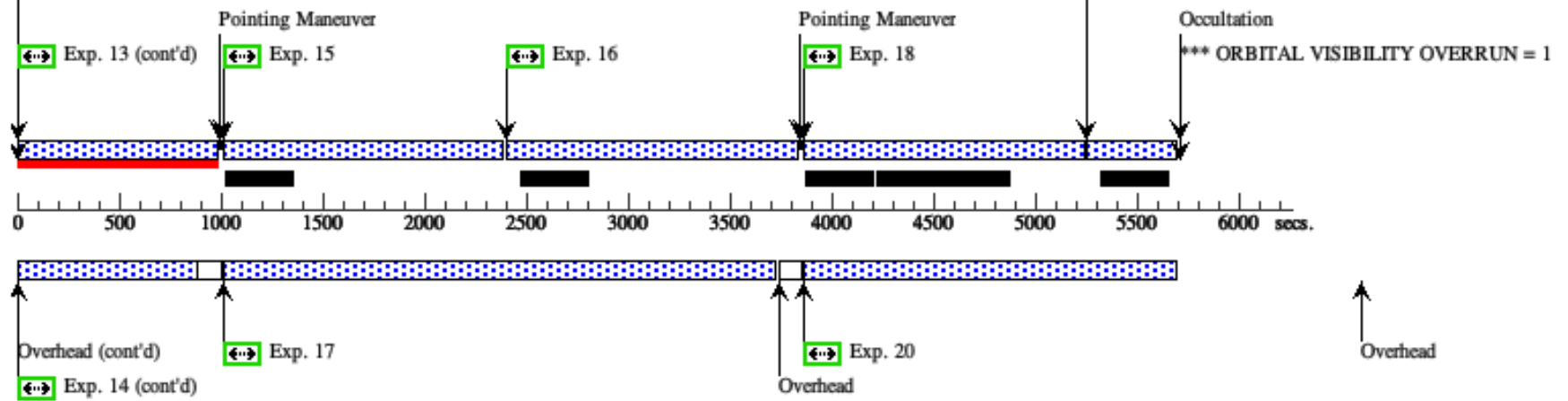

**Orbit 4**

Server Version: 20220630

\*\*\* ORBITAL VISIBILITY OVERRUN = 997 (cont'd)

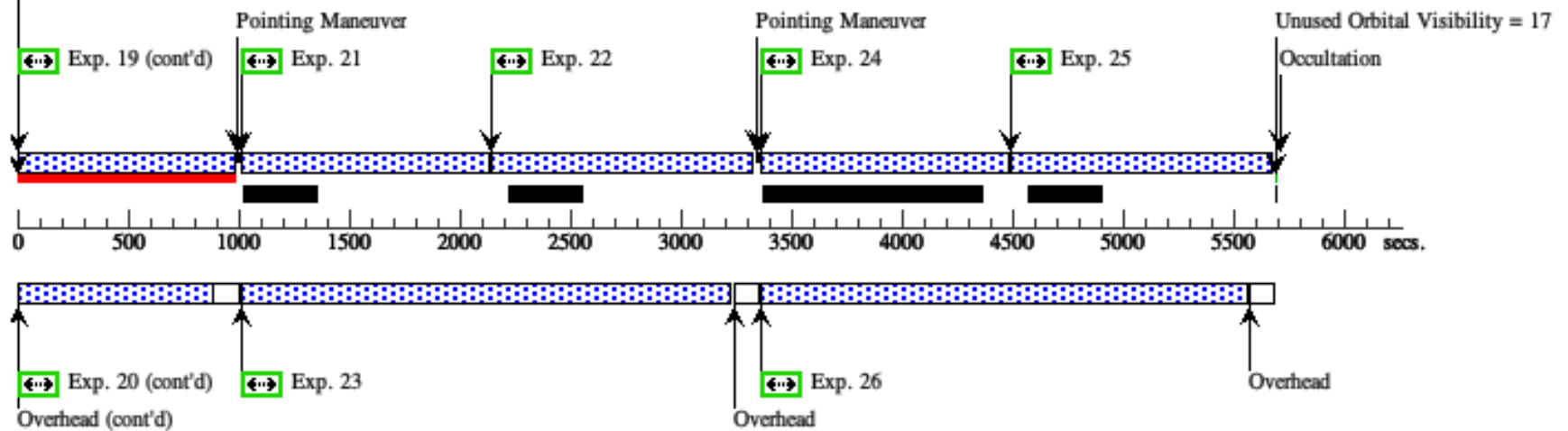

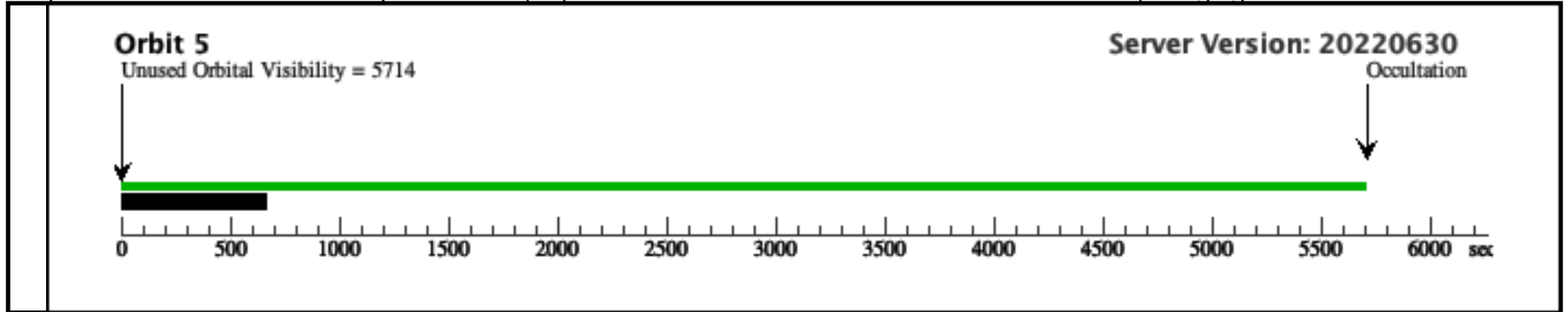

Proposal 16252 - treasurehunt-epoch02of13 (02) - TREASUREHUNT: Hubble's UV-Visible treasury imaging of the JWST NEP Time-...

Visit	<p><b>Proposal 16252, treasurehunt-epoch02of13 (02), completed</b> <span style="float: right;">Tue Oct 25 19:01:01 GMT 2022</span></p> <p><b>Diagnostic Status: Error</b></p> <p>Scientific Instruments: WFC3/UVIS, ACS/WFC</p> <p>Special Requirements: BRIGHT EARTH AVOID 13.5D; ORIENT 023D TO 023 D; BETWEEN 2020.326:00:21:02 AND 2020.326:00:27:02; BETWEEN 2020.327:00:11:02 AND 2020.327:00:17:02; BETWEEN 2020.328:00:01:03 AND 2020.328:00:07:03; BETWEEN 2020.328:23:51:06 AND 2020.328:23:57:06; BETWEEN 2020.329:23:41:08 AND 2020.329:23:47:08; VISIBILITY INTERVAL 5714 S</p> <p><i>Comments: Epoch 02 of 13 is a 4-orbit (pseudo)CVZ visit, using the opportunity at ORIENT = 023 degrees. After guide star acquisition at the start of the first orbit, the guide star remains visible and locked for the duration of the visit, so no guide star re-acquisition in subsequent orbits will be required in orbits 2-4. This strategy is the same as adopted for GO-15278 in Cycle 25, and as successfully executed through Cycle 27. Specified POS_TARGs with respect to the nominal field center place the instrument apertures at the intended location within the 13-epoch pattern. While APT throws an error for the specified Bright Earth Avoidance angle of 13.5 degrees, this value is intended and proven to schedule and execute for a pseudo-CVZ visit.</i></p>													
Diagnostics	<p>(treasurehunt-epoch02of13 (02)) Error (Form): The specified Bright Earth Avoidance angle is outside the permitted range.</p> <p>(treasurehunt-epoch02of13 (02)) Warning (Orbit Planner): NO VISIBILITY TABLE CORRESPONDING TO BRIGHT EARTH AVOIDANCE ANGLE</p> <p>(treasurehunt-epoch02of13 (02)) Warning (Orbit Planner): ORBITAL VISIBILITY OVERRUN</p> <p>(treasurehunt-epoch02of13 (02)) Warning (Orbit Planner): ORBITAL VISIBILITY OVERRUN</p> <p>(treasurehunt-epoch02of13 (02)) Warning (Orbit Planner): ORBITAL VISIBILITY OVERRUN</p> <p>(treasurehunt-epoch02of13 (02)) Warning (Orbit Planner): POS TARG OUTSIDE OF APERTURE</p> <p>(treasurehunt-epoch02of13 (02)) Warning (Orbit Planner): POS TARG OUTSIDE OF APERTURE</p> <p>(treasurehunt-epoch02of13 (02)) Warning (Orbit Planner): POS TARG OUTSIDE OF APERTURE</p> <p>(treasurehunt-epoch02of13 (02)) Warning (Orbit Planner): POS TARG OUTSIDE OF APERTURE</p> <p>(treasurehunt-epoch02of13 (02)) Warning (Orbit Planner): POS TARG OUTSIDE OF APERTURE</p> <p>(treasurehunt-epoch02of13 (02)) Warning (Orbit Planner): POS TARG OUTSIDE OF APERTURE</p> <p>(treasurehunt-epoch02of13 (02)) Warning (Orbit Planner): POS TARG OUTSIDE OF APERTURE</p> <p>(treasurehunt-epoch02of13 (02)) Warning (Orbit Planner): POS TARG OUTSIDE OF APERTURE</p> <p>(treasurehunt-epoch02of13 (02)) Warning (Orbit Planner): POS TARG OUTSIDE OF APERTURE</p> <p>(treasurehunt-epoch02of13 (02)) Warning (Orbit Planner): POS TARG OUTSIDE OF APERTURE</p> <p>(treasurehunt-epoch02of13 (02)) Warning (Orbit Planner): POS TARG OUTSIDE OF APERTURE</p> <p>(treasurehunt-epoch02of13 (02)) Warning (Orbit Planner): POS TARG OUTSIDE OF APERTURE</p> <p>(treasurehunt-epoch02of13 (02)) Warning (Orbit Planner): POS TARG OUTSIDE OF APERTURE</p> <p>(treasurehunt-epoch02of13 (02)) Warning (Orbit Planner): POS TARG OUTSIDE OF APERTURE</p> <p>(treasurehunt-epoch02of13 (02)) Warning (Orbit Planner): POS TARG OUTSIDE OF APERTURE</p> <p>(treasurehunt-epoch02of13 (02)) Warning (Orbit Planner): POS TARG OUTSIDE OF APERTURE</p> <p>(treasurehunt-epoch02of13 (02)) Warning (Orbit Planner): POS TARG OUTSIDE OF APERTURE</p> <p>(treasurehunt-epoch02of13 (02)) Warning (Orbit Planner): POS TARG OUTSIDE OF APERTURE</p> <p>(treasurehunt-epoch02of13 (02)) Warning (Orbit Planner): POS TARG OUTSIDE OF APERTURE</p>													
Fixed Targets	<table border="1"> <thead> <tr> <th>#</th> <th>Name</th> <th>Target Coordinates</th> <th>Targ. Coord. Corrections</th> <th>Fluxes</th> <th>Miscellaneous</th> </tr> </thead> <tbody> <tr> <td>(1)</td> <td>JWST-NEP-TDF</td> <td>RA: 17 22 47.8960 (260.6995667d) Dec: +65 49 21.54 (65.82265d) Equinox: J2000</td> <td></td> <td>V=27.0+/-1.0</td> <td>Reference Frame: ICRS</td> </tr> </tbody> </table>	#	Name	Target Coordinates	Targ. Coord. Corrections	Fluxes	Miscellaneous	(1)	JWST-NEP-TDF	RA: 17 22 47.8960 (260.6995667d) Dec: +65 49 21.54 (65.82265d) Equinox: J2000		V=27.0+/-1.0	Reference Frame: ICRS	<p><i>Comments: The target field is centered on the extant HST observations of the JWST NEP Time-Domain Field of GO-15278. Allocated JWST GTO observations will provide both NIRCам imaging and NIRISS slitless spectroscopy in this field, which was defined to be the cleanest ~14' diameter area in JWST's northern continuous viewing zone, where JWST will conduct a deep extragalactic time-domain survey, with added utility for extreme outer solar system and near-Galactic time-domain science. The JWST NEP Time-Domain Field is developed as a *community field*, and has deep coverage across the electromagnetic spectrum from X-ray through long-wave radio. The present Cycle 28+29 HST program will complete near-contiguous 3-filter coverage in the UV-Visible, targeting the annulus surrounding the extant HST observations of GO-15278. The present Phase-II APT specifies the Cycle 28 pointings within that annulus.</i></p> <p>Category=UNIDENTIFIED Description=[HIGH LATITUDE FIELD, INFRARED EMITTER, OPTICAL EMITTER, ULTRAVIOLET EMITTER]</p>
#	Name	Target Coordinates	Targ. Coord. Corrections	Fluxes	Miscellaneous									
(1)	JWST-NEP-TDF	RA: 17 22 47.8960 (260.6995667d) Dec: +65 49 21.54 (65.82265d) Equinox: J2000		V=27.0+/-1.0	Reference Frame: ICRS									

Proposal 16252 - treasurehunt-epoch02of13 (02) - TREASUREHUNT: Hubble's UV-Visible treasury imaging of the JWST NEP Time-...

#	Label (ETC Run)	Target	Config,Mode,Aperture	Spectral Els.	Opt. Params.	Special Reqs.	Groups	Exp. Time (Total)/[Actual Dur.]	Orbit
1		(1) JWST-NEP-TDF	ACS/WFC, ACCUM, WFCENTER	F435W		POS TARG 6.9,380.1; GS ACQ SCENARIO BASE1BE	Sequence 1-26 Non-Int in treasurehunt-epoch02of13 (02)  Prime + Parallel Group 1-2 in Sequence 1-26 Non-Int in treasurehunt-epoch02of13 (02)	800 Secs (800 Secs) [==>]	[1]
2		ANY	WFC3/UVIS, ACCUM, UVIS	F275W	FLASH=17		Sequence 1-26 Non-Int in treasurehunt-epoch02of13 (02)  Prime + Parallel Group 1-2 in Sequence 1-26 Non-Int in treasurehunt-epoch02of13 (02)	851 Secs (851 Secs) [==>]	[1]
3		(1) JWST-NEP-TDF	ACS/WFC, ACCUM, WFCENTER	F435W		POS TARG +6.900,+380.100	Sequence 1-26 Non-Int in treasurehunt-epoch02of13 (02)  Prime + Parallel Group 3-5 in Sequence 1-26 Non-Int in treasurehunt-epoch02of13 (02)	1160 Secs (1160 Secs) [==>]	[1]
<p><i>Comments: The specified POS_TARG values intentionally place the WFC3/UVIS and ACS/WFC instrument apertures off the coordinates of the target (i.e., the center of the JWST NEP Time-Domain Field) to their intended locations within an annulus surrounding the extant HST data.</i></p>									
4		(1) JWST-NEP-TDF	ACS/WFC, ACCUM, WFCENTER	F606W		POS TARG +6.900,+380.100	Sequence 1-26 Non-Int in treasurehunt-epoch02of13 (02)  Prime + Parallel Group 3-5 in Sequence 1-26 Non-Int in treasurehunt-epoch02of13 (02)	1160 Secs (1160 Secs) [==>]	[1]
5	(WFC3UVIS.im.1445613)	ANY	WFC3/UVIS, ACCUM, UVIS	F275W	FLASH=11		Sequence 1-26 Non-Int in treasurehunt-epoch02of13 (02)  Prime + Parallel Group 3-5 in Sequence 1-26 Non-Int in treasurehunt-epoch02of13 (02)	2545 Secs (2545 Secs) [==>]	[1]
<p><i>Comments: Following the June 4 2020 recommendations of J. Anderson (2020) "CURRENT CTE-MITIGATION RECOMMENDATIONS", we aim for a minimum background level of 20 e-/pix in each WFC3/UVIS F275W exposure. Taking into account the raised natural background of this pseudo-CVZ visit, the WFC3/UVIS ETC shows that this requirement becomes satisfied for FLASH=11. The APT Phase-II diagnostics seem to still test the older (now superseded) recommendation of a minimum of only 12 e-/pix, and therefore result in a warning that the specified postflash may be too high.</i></p>									
6		(1) JWST-NEP-TDF	ACS/WFC, ACCUM, WFCENTER	F606W		POS TARG +7.100,+380.100	Sequence 1-26 Non-Int in treasurehunt-epoch02of13 (02)  Prime + Parallel Group 6-8 in Sequence 1-26 Non-Int in treasurehunt-epoch02of13 (02)	1140 Secs (1140 Secs) [==>]	[1]
<p><i>Comments: The specified POS_TARG values intentionally place the WFC3/UVIS and ACS/WFC instrument apertures off the coordinates of the target (i.e., the center of the JWST NEP Time-Domain Field) to their intended locations within an annulus surrounding the extant HST data.</i></p>									

Proposal 16252 - treasurehunt-epoch02of13 (02) - TREASUREHUNT: Hubble's UV-Visible treasury imaging of the JWST NEP Time...

7	(1) JWST-NEP-TDF ACS/WFC, ACCUM, WFCENTER F435W	POS TARG +7.100, +380.100	Sequence 1-26 Non-Int in treasurehunt-epoch02of13 (02) Prime + Parallel Group 6-8 in Sequence 1-26 Non-Int in treasurehunt-epoch02of13 (02)	1140 Secs (1140 Secs) [==>]	[1]
8	(WFC3UVI ANY S.im.1445613) WFC3/UVIS, ACCUM, UVIS F275W FLASH=11		Sequence 1-26 Non-Int in treasurehunt-epoch02of13 (02) Prime + Parallel Group 6-8 in Sequence 1-26 Non-Int in treasurehunt-epoch02of13 (02)	2504 Secs (2504 Secs) [==>]	[1]
<p><i>Comments: Following the June 4 2020 recommendations of J. Anderson (2020) "CURRENT CTE-MITIGATION RECOMMENDATIONS", we aim for a minimum background level of 20 e-/pix in each WFC3/UVIS F275W exposure. Taking into account the raised natural background of this pseudo-CVZ visit, the WFC3/UVIS ETC shows that this requirement becomes satisfied for FLASH=11. The APT Phase-II diagnostics seem to still test the older (now superseded) recommendation of a minimum of only 12 e-/pix, and therefore result in a warning that the specified postflash may be too high.</i></p>					
9	(1) JWST-NEP-TDF ACS/WFC, ACCUM, WFCENTER F435W	POS TARG +6.900, +379.900	Sequence 1-26 Non-Int in treasurehunt-epoch02of13 (02) Prime + Parallel Group 9-11 in Sequence 1-26 Non-Int in treasurehunt-epoch02of13 (02)	1245 Secs (1245 Secs) [==>]	[2]
<p><i>Comments: The specified POS_TARG values intentionally place the WFC3/UVIS and ACS/WFC instrument apertures off the coordinates of the target (i.e., the center of the JWST NEP Time-Domain Field) to their intended locations within an annulus surrounding the extant HST data.</i></p>					
10	(1) JWST-NEP-TDF ACS/WFC, ACCUM, WFCENTER F606W	POS TARG +6.900, +379.900	Sequence 1-26 Non-Int in treasurehunt-epoch02of13 (02) Prime + Parallel Group 9-11 in Sequence 1-26 Non-Int in treasurehunt-epoch02of13 (02)	1245 Secs (1245 Secs) [==>]	[2]
11	(WFC3UVI ANY S.im.1445613) WFC3/UVIS, ACCUM, UVIS F275W FLASH=11		Sequence 1-26 Non-Int in treasurehunt-epoch02of13 (02) Prime + Parallel Group 9-11 in Sequence 1-26 Non-Int in treasurehunt-epoch02of13 (02)	2714 Secs (2714 Secs) [==>]	[2]
<p><i>Comments: Following the June 4 2020 recommendations of J. Anderson (2020) "CURRENT CTE-MITIGATION RECOMMENDATIONS", we aim for a minimum background level of 20 e-/pix in each WFC3/UVIS F275W exposure. Taking into account the raised natural background of this pseudo-CVZ visit, the WFC3/UVIS ETC shows that this requirement becomes satisfied for FLASH=11. The APT Phase-II diagnostics seem to still test the older (now superseded) recommendation of a minimum of only 12 e-/pix, and therefore result in a warning that the specified postflash may be too high.</i></p>					
12	(1) JWST-NEP-TDF ACS/WFC, ACCUM, WFCENTER F606W	POS TARG +7.100, +379.900	Sequence 1-26 Non-Int in treasurehunt-epoch02of13 (02) Prime + Parallel Group 12-14 in Sequence 1-26 Non-Int in treasurehunt-epoch02of13 (02)	1253 Secs (1253 Secs) [==>]	[2]
<p><i>Comments: The specified POS_TARG values intentionally place the WFC3/UVIS and ACS/WFC instrument apertures off the coordinates of the target (i.e., the center of the JWST NEP Time-Domain Field) to their intended locations within an annulus surrounding the extant HST data.</i></p>					

Proposal 16252 - treasurehunt-epoch02of13 (02) - TREASUREHUNT: Hubble's UV-Visible treasury imaging of the JWST NEP Time...

13	(1) JWST-NEP-TDF ACS/WFC, ACCUM, WFCENTER F435W	POS TARG +7.100, +379.900	Sequence 1-26 Non-Int in treasurehunt-epoch02of13 (02) Prime + Parallel Group 12-14 in Sequence 1-26 Non-Int in treasurehunt-epoch02of13 (02)	1254 Secs (1254 Secs) [==>]	[2]
14	(WFC3UVI ANY S.im.1445613) WFC3/UVIS, ACCUM, UVIS F275W FLASH=11		Sequence 1-26 Non-Int in treasurehunt-epoch02of13 (02) Prime + Parallel Group 12-14 in Sequence 1-26 Non-Int in treasurehunt-epoch02of13 (02)	2731 Secs (2731 Secs) [==>]	[2]
<p><i>Comments: Following the June 4 2020 recommendations of J. Anderson (2020) "CURRENT CTE-MITIGATION RECOMMENDATIONS", we aim for a minimum background level of 20 e-/pix in each WFC3/UVIS F275W exposure. Taking into account the raised natural background of this pseudo-CVZ visit, the WFC3/UVIS ETC shows that this requirement becomes satisfied for FLASH=11. The APT Phase-II diagnostics seem to still test the older (now superseded) recommendation of a minimum of only 12 e-/pix, and therefore result in a warning that the specified postflash may be too high.</i></p>					
15	(1) JWST-NEP-TDF ACS/WFC, ACCUM, WFCENTER F435W	POS TARG +6.800, +380.200	Sequence 1-26 Non-Int in treasurehunt-epoch02of13 (02) Prime + Parallel Group 15-17 in Sequence 1-26 Non-Int in treasurehunt-epoch02of13 (02)	1245 Secs (1245 Secs) [==>]	[3]
<p><i>Comments: The specified POS_TARG values intentionally place the WFC3/UVIS and ACS/WFC instrument apertures off the coordinates of the target (i.e., the center of the JWST NEP Time-Domain Field) to their intended locations within an annulus surrounding the extant HST data.</i></p>					
16	(1) JWST-NEP-TDF ACS/WFC, ACCUM, WFCENTER F606W	POS TARG +6.800, +380.200	Sequence 1-26 Non-Int in treasurehunt-epoch02of13 (02) Prime + Parallel Group 15-17 in Sequence 1-26 Non-Int in treasurehunt-epoch02of13 (02)	1245 Secs (1245 Secs) [==>]	[3]
17	(WFC3UVI ANY S.im.1445613) WFC3/UVIS, ACCUM, UVIS F275W FLASH=11		Sequence 1-26 Non-Int in treasurehunt-epoch02of13 (02) Prime + Parallel Group 15-17 in Sequence 1-26 Non-Int in treasurehunt-epoch02of13 (02)	2714 Secs (2714 Secs) [==>]	[3]
<p><i>Comments: Following the June 4 2020 recommendations of J. Anderson (2020) "CURRENT CTE-MITIGATION RECOMMENDATIONS", we aim for a minimum background level of 20 e-/pix in each WFC3/UVIS F275W exposure. Taking into account the raised natural background of this pseudo-CVZ visit, the WFC3/UVIS ETC shows that this requirement becomes satisfied for FLASH=11. The APT Phase-II diagnostics seem to still test the older (now superseded) recommendation of a minimum of only 12 e-/pix, and therefore result in a warning that the specified postflash may be too high.</i></p>					
18	(1) JWST-NEP-TDF ACS/WFC, ACCUM, WFCENTER F606W	POS TARG +7.000, +380.200	Sequence 1-26 Non-Int in treasurehunt-epoch02of13 (02) Prime + Parallel Group 18-20 in Sequence 1-26 Non-Int in treasurehunt-epoch02of13 (02)	1253 Secs (1253 Secs) [==>]	[3]
<p><i>Comments: The specified POS_TARG values intentionally place the WFC3/UVIS and ACS/WFC instrument apertures off the coordinates of the target (i.e., the center of the JWST NEP Time-Domain Field) to their intended locations within an annulus surrounding the extant HST data.</i></p>					

Proposal 16252 - treasurehunt-epoch02of13 (02) - TREASUREHUNT: Hubble's UV-Visible treasury imaging of the JWST NEP Time-...

19	(1) JWST-NEP-TDF ACS/WFC, ACCUM, WFCENTER F435W	POS TARG +7.000, +380.200	Sequence 1-26 Non-Int in treasurehunt-epoch02of13 (02) Prime + Parallel Group 18-20 in Sequence 1-26 Non-Int in treasurehunt-epoch02of13 (02)	1254 Secs (1254 Secs) [==>]	[3]
20	(WFC3UVI ANY S.im.1445613) WFC3/UVIS, ACCUM, UVIS F275W FLASH=11		Sequence 1-26 Non-Int in treasurehunt-epoch02of13 (02) Prime + Parallel Group 18-20 in Sequence 1-26 Non-Int in treasurehunt-epoch02of13 (02)	2731 Secs (2731 Secs) [==>]	[3]
<p><i>Comments: Following the June 4 2020 recommendations of J. Anderson (2020) "CURRENT CTE-MITIGATION RECOMMENDATIONS", we aim for a minimum background level of 20 e-/pix in each WFC3/UVIS F275W exposure. Taking into account the raised natural background of this pseudo-CVZ visit, the WFC3/UVIS ETC shows that this requirement becomes satisfied for FLASH=11. The APT Phase-II diagnostics seem to still test the older (now superseded) recommendation of a minimum of only 12 e-/pix, and therefore result in a warning that the specified postflash may be too high.</i></p>					
21	(1) JWST-NEP-TDF ACS/WFC, ACCUM, WFCENTER F435W	POS TARG +6.800, +380.000	Sequence 1-26 Non-Int in treasurehunt-epoch02of13 (02) Prime + Parallel Group 21-23 in Sequence 1-26 Non-Int in treasurehunt-epoch02of13 (02)	994 Secs (994 Secs) [==>]	[4]
<p><i>Comments: The specified POS_TARG values intentionally place the WFC3/UVIS and ACS/WFC instrument apertures off the coordinates of the target (i.e., the center of the JWST NEP Time-Domain Field) to their intended locations within an annulus surrounding the extant HST data.</i></p>					
22	(1) JWST-NEP-TDF ACS/WFC, ACCUM, WFCENTER F606W	POS TARG +6.800, +380.000	Sequence 1-26 Non-Int in treasurehunt-epoch02of13 (02) Prime + Parallel Group 21-23 in Sequence 1-26 Non-Int in treasurehunt-epoch02of13 (02)	994 Secs (994 Secs) [==>]	[4]
23	(WFC3UVI ANY S.im.1445644) WFC3/UVIS, ACCUM, UVIS F275W FLASH=12		Sequence 1-26 Non-Int in treasurehunt-epoch02of13 (02) Prime + Parallel Group 21-23 in Sequence 1-26 Non-Int in treasurehunt-epoch02of13 (02)	2212 Secs (2212 Secs) [==>]	[4]
<p><i>Comments: Following the June 4 2020 recommendations of J. Anderson (2020) "CURRENT CTE-MITIGATION RECOMMENDATIONS", we aim for a minimum background level of 20 e-/pix in each WFC3/UVIS F275W exposure. Taking into account the raised natural background of this pseudo-CVZ visit, the WFC3/UVIS ETC shows that this requirement becomes satisfied for FLASH=12. The APT Phase-II diagnostics seem to still test the older (now superseded) recommendation of a minimum of only 12 e-/pix, and therefore result in a warning that the specified postflash may be too high.</i></p>					
24	(1) JWST-NEP-TDF ACS/WFC, ACCUM, WFCENTER F606W	POS TARG +7.000, +380.000	Sequence 1-26 Non-Int in treasurehunt-epoch02of13 (02) Prime + Parallel Group 24-26 in Sequence 1-26 Non-Int in treasurehunt-epoch02of13 (02)	997 Secs (997 Secs) [==>]	[4]
<p><i>Comments: The specified POS_TARG values intentionally place the WFC3/UVIS and ACS/WFC instrument apertures off the coordinates of the target (i.e., the center of the JWST NEP Time-Domain Field) to their intended locations within an annulus surrounding the extant HST data.</i></p>					

Proposal 16252 - treasurehunt-epoch02of13 (02) - TREASUREHUNT: Hubble's UV-Visible treasury imaging of the JWST NEP Time-...

25	(1) JWST-NEP-TDF ACS/WFC, ACCUM, WFCENTER F435W	POS TARG +7.000, +380.000	Sequence 1-26 Non-Int in treasurehunt-epoch02of13 (02)  Prime + Parallel Group 24-26 in Sequence 1-26 Non-Int in treasurehunt-epoch02of13 (02)	997 Secs (997 Secs) [==>]	[4]
26	(WFC3UVI ANY S.im.144564 4) WFC3/UVIS, ACCUM, UVIS F275W FLASH=12		Sequence 1-26 Non-Int in treasurehunt-epoch02of13 (02)  Prime + Parallel Group 24-26 in Sequence 1-26 Non-Int in treasurehunt-epoch02of13 (02)	2198 Secs (2198 Secs) [==>]	[4]
<p><i>Comments: Following the June 4 2020 recommendations of J. Anderson (2020) "CURRENT CTE-MITIGATION RECOMMENDATIONS", we aim for a minimum background level of 20 e-/pix in each WFC3/UVIS F275W exposure. Taking into account the raised natural background of this pseudo-CVZ visit, the WFC3/UVIS ETC shows that this requirement becomes satisfied for FLASH=12. The APT Phase-II diagnostics seem to still test the older (now superseded) recommendation of a minimum of only 12 e-/pix, and therefore result in a warning that the specified postflash may be too high.</i></p>					

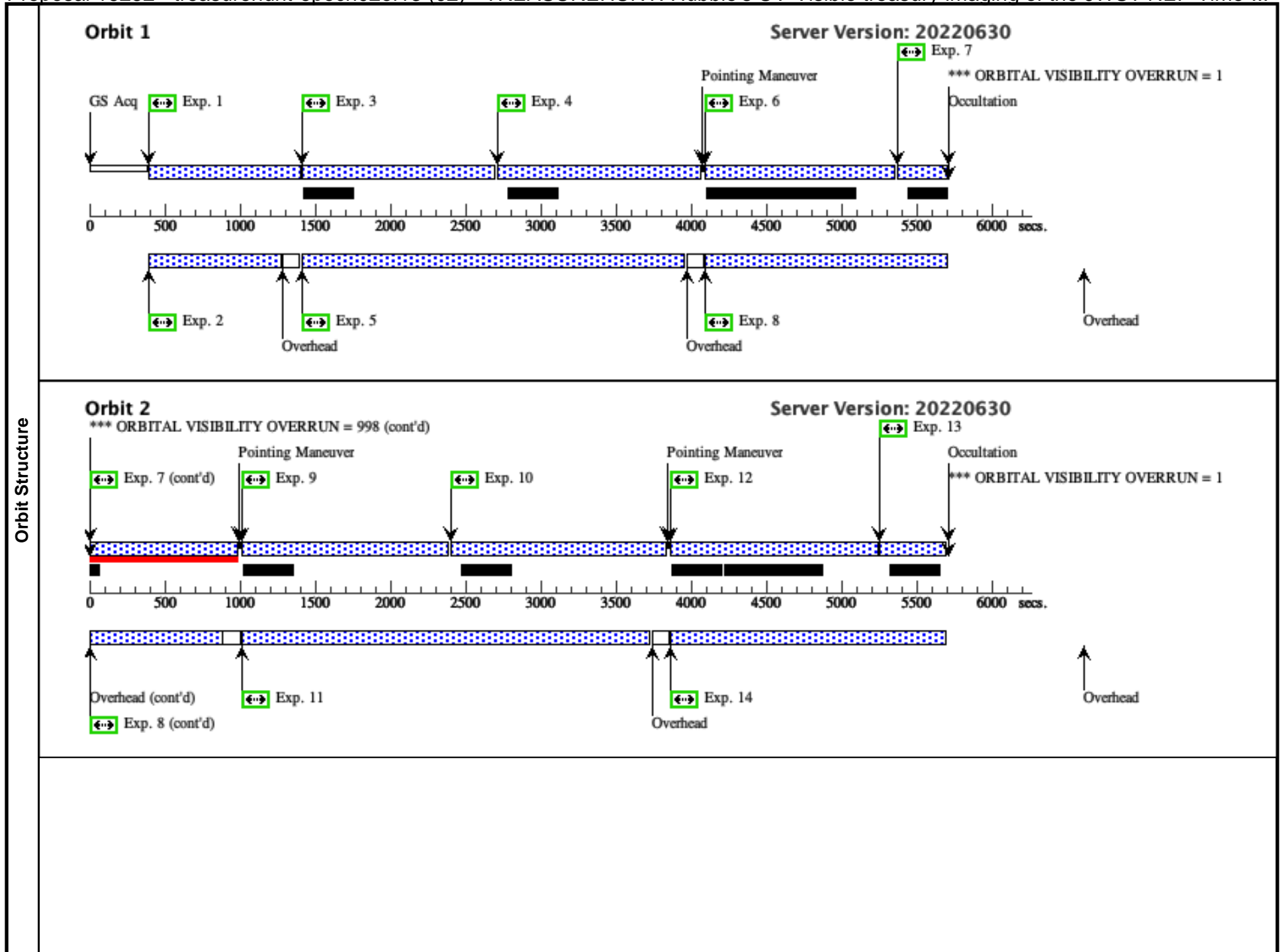

**Orbit 3**

Server Version: 20220630

\*\*\* ORBITAL VISIBILITY OVERRUN = 998 (cont'd)

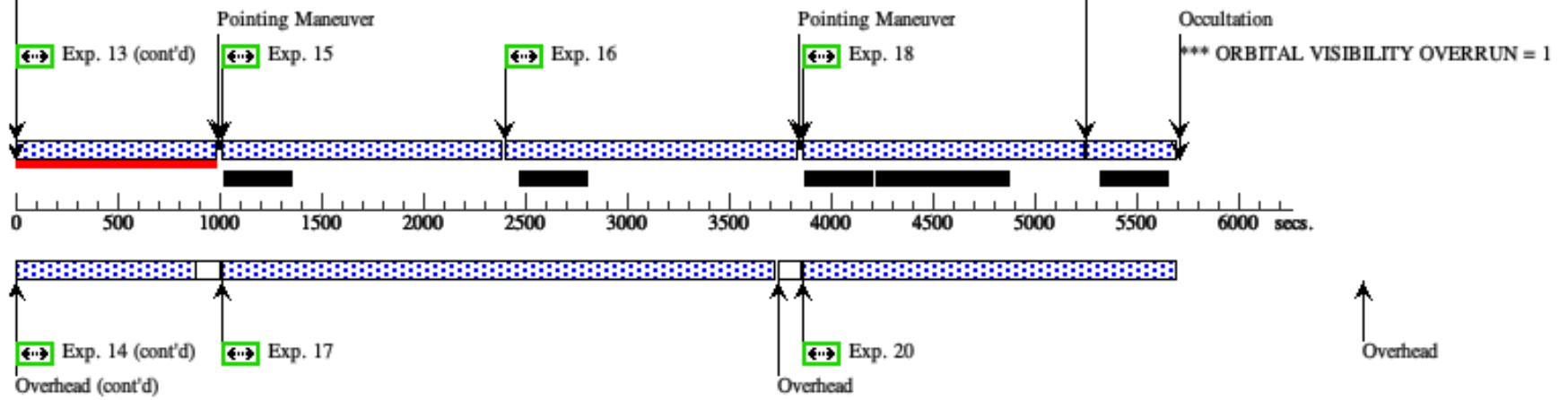

**Orbit 4**

Server Version: 20220630

\*\*\* ORBITAL VISIBILITY OVERRUN = 998 (cont'd)

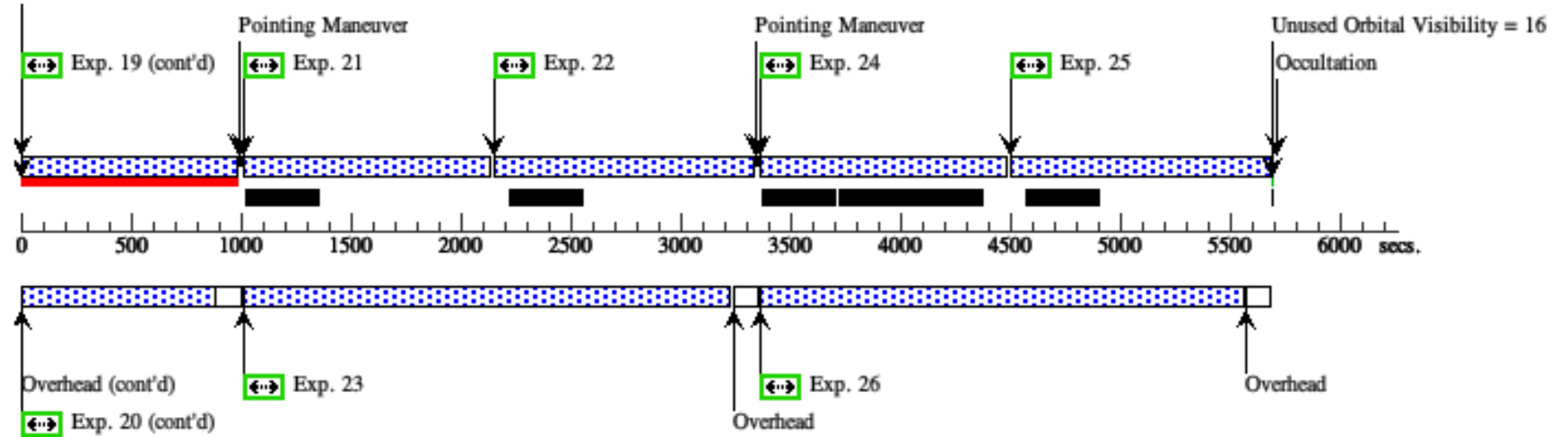

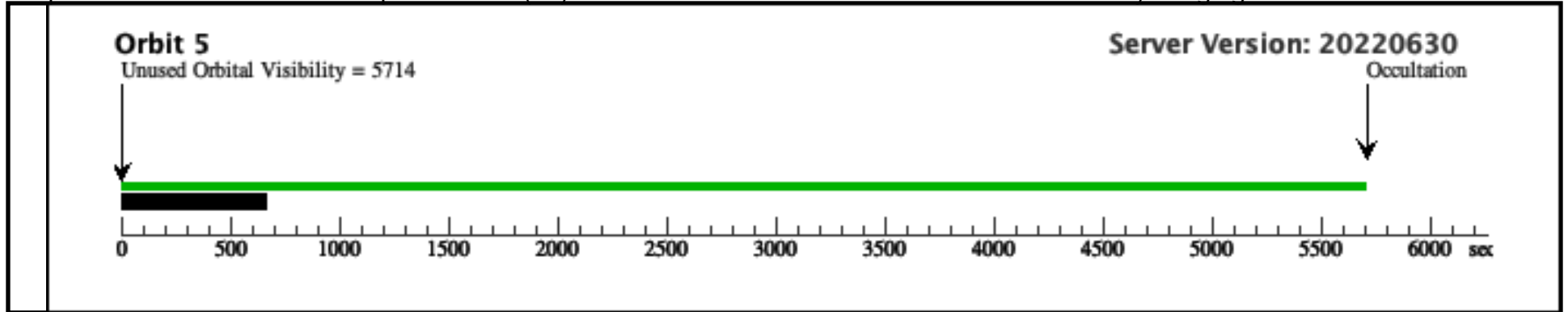



Proposal 16252 - treasurehunt-epoch03of13 (03) - TREASUREHUNT: Hubble's UV-Visible treasury imaging of the JWST NEP Time-...

#	Label (ETC Run)	Target	Config,Mode,Aperture	Spectral Els.	Opt. Params.	Special Reqs.	Groups	Exp. Time (Total)/[Actual Dur.]	Orbit
1		(1) JWST-NEP-TDF	ACS/WFC, ACCUM, WFCENTER	F435W		POS TARG 57.9,355.1; GS ACQ SCENARIO BASE1BE	Sequence 1-26 Non-Int in treasurehunt-epoch03of13 (03)  Prime + Parallel Group 1-2 in Sequence 1-26 Non-Int in treasurehunt-epoch03of13 (03)	740 Secs (740 Secs) [==>]	[1]
2		ANY	WFC3/UVIS, ACCUM, UVIS	F275W	FLASH=17		Sequence 1-26 Non-Int in treasurehunt-epoch03of13 (03)  Prime + Parallel Group 1-2 in Sequence 1-26 Non-Int in treasurehunt-epoch03of13 (03)	790 Secs (790 Secs) [==>]	[1]
3		(1) JWST-NEP-TDF	ACS/WFC, ACCUM, WFCENTER	F435W		POS TARG +57.900,+355.100	Sequence 1-26 Non-Int in treasurehunt-epoch03of13 (03)  Prime + Parallel Group 3-5 in Sequence 1-26 Non-Int in treasurehunt-epoch03of13 (03)	1136 Secs (1136 Secs) [==>]	[1]
<p><i>Comments: The specified POS_TARG values intentionally place the WFC3/UVIS and ACS/WFC instrument apertures off the coordinates of the target (i.e., the center of the JWST NEP Time-Domain Field) to their intended locations within an annulus surrounding the extant HST data.</i></p>									
4		(1) JWST-NEP-TDF	ACS/WFC, ACCUM, WFCENTER	F606W		POS TARG +57.900,+355.100	Sequence 1-26 Non-Int in treasurehunt-epoch03of13 (03)  Prime + Parallel Group 3-5 in Sequence 1-26 Non-Int in treasurehunt-epoch03of13 (03)	1136 Secs (1136 Secs) [==>]	[1]
5	(WFC3UVIS.im.1445613)	ANY	WFC3/UVIS, ACCUM, UVIS	F275W	FLASH=11		Sequence 1-26 Non-Int in treasurehunt-epoch03of13 (03)  Prime + Parallel Group 3-5 in Sequence 1-26 Non-Int in treasurehunt-epoch03of13 (03)	2545 Secs (2545 Secs) [==>]	[1]
<p><i>Comments: Following the June 4 2020 recommendations of J. Anderson (2020) "CURRENT CTE-MITIGATION RECOMMENDATIONS", we aim for a minimum background level of 20 e-/pix in each WFC3/UVIS F275W exposure. Taking into account the raised natural background of this pseudo-CVZ visit, the WFC3/UVIS ETC shows that this requirement becomes satisfied for FLASH=11. The APT Phase-II diagnostics seem to still test the older (now superseded) recommendation of a minimum of only 12 e-/pix, and therefore result in a warning that the specified postflash may be too high.</i></p>									
6		(1) JWST-NEP-TDF	ACS/WFC, ACCUM, WFCENTER	F606W		POS TARG +58.100,+355.100	Sequence 1-26 Non-Int in treasurehunt-epoch03of13 (03)  Prime + Parallel Group 6-8 in Sequence 1-26 Non-Int in treasurehunt-epoch03of13 (03)	1140 Secs (1140 Secs) [==>]	[1]
<p><i>Comments: The specified POS_TARG values intentionally place the WFC3/UVIS and ACS/WFC instrument apertures off the coordinates of the target (i.e., the center of the JWST NEP Time-Domain Field) to their intended locations within an annulus surrounding the extant HST data.</i></p>									

Proposal 16252 - treasurehunt-epoch03of13 (03) - TREASUREHUNT: Hubble's UV-Visible treasury imaging of the JWST NEP Time...

7	(1) JWST-NEP-TDF ACS/WFC, ACCUM, WFCENTER F435W	POS TARG +58.100 ,+355.100	Sequence 1-26 Non-Int in treasurehunt-epoch03of13 (03)  Prime + Parallel Group 6-8 in Sequence 1-26 Non-Int in treasurehunt-epoch03of13 (03)	1140 Secs (1140 Secs) [==>]	[1]
8	(WFC3UVI ANY S.im.1445613) WFC3/UVIS, ACCUM, UVIS F275W FLASH=11		Sequence 1-26 Non-Int in treasurehunt-epoch03of13 (03)  Prime + Parallel Group 6-8 in Sequence 1-26 Non-Int in treasurehunt-epoch03of13 (03)	2504 Secs (2504 Secs) [==>]	[1]
<p><i>Comments: Following the June 4 2020 recommendations of J. Anderson (2020) "CURRENT CTE-MITIGATION RECOMMENDATIONS", we aim for a minimum background level of 20 e-/pix in each WFC3/UVIS F275W exposure. Taking into account the raised natural background of this pseudo-CVZ visit, the WFC3/UVIS ETC shows that this requirement becomes satisfied for FLASH=11. The APT Phase-II diagnostics seem to still test the older (now superseded) recommendation of a minimum of only 12 e-/pix, and therefore result in a warning that the specified postflash may be too high.</i></p>					
9	(1) JWST-NEP-TDF ACS/WFC, ACCUM, WFCENTER F435W	POS TARG +57.900 ,+354.900	Sequence 1-26 Non-Int in treasurehunt-epoch03of13 (03)  Prime + Parallel Group 9-11 in Sequence 1-26 Non-Int in treasurehunt-epoch03of13 (03)	1245 Secs (1245 Secs) [==>]	[2]
<p><i>Comments: The specified POS_TARG values intentionally place the WFC3/UVIS and ACS/WFC instrument apertures off the coordinates of the target (i.e., the center of the JWST NEP Time-Domain Field) to their intended locations within an annulus surrounding the extant HST data.</i></p>					
10	(1) JWST-NEP-TDF ACS/WFC, ACCUM, WFCENTER F606W	POS TARG +57.900 ,+354.900	Sequence 1-26 Non-Int in treasurehunt-epoch03of13 (03)  Prime + Parallel Group 9-11 in Sequence 1-26 Non-Int in treasurehunt-epoch03of13 (03)	1245 Secs (1245 Secs) [==>]	[2]
11	(WFC3UVI ANY S.im.1445613) WFC3/UVIS, ACCUM, UVIS F275W FLASH=11		Sequence 1-26 Non-Int in treasurehunt-epoch03of13 (03)  Prime + Parallel Group 9-11 in Sequence 1-26 Non-Int in treasurehunt-epoch03of13 (03)	2714 Secs (2714 Secs) [==>]	[2]
<p><i>Comments: Following the June 4 2020 recommendations of J. Anderson (2020) "CURRENT CTE-MITIGATION RECOMMENDATIONS", we aim for a minimum background level of 20 e-/pix in each WFC3/UVIS F275W exposure. Taking into account the raised natural background of this pseudo-CVZ visit, the WFC3/UVIS ETC shows that this requirement becomes satisfied for FLASH=11. The APT Phase-II diagnostics seem to still test the older (now superseded) recommendation of a minimum of only 12 e-/pix, and therefore result in a warning that the specified postflash may be too high.</i></p>					
12	(1) JWST-NEP-TDF ACS/WFC, ACCUM, WFCENTER F606W	POS TARG +58.100 ,+354.900	Sequence 1-26 Non-Int in treasurehunt-epoch03of13 (03)  Prime + Parallel Group 12-14 in Sequence 1-26 Non-Int in treasurehunt-epoch03of13 (03)	1253 Secs (1253 Secs) [==>]	[2]
<p><i>Comments: The specified POS_TARG values intentionally place the WFC3/UVIS and ACS/WFC instrument apertures off the coordinates of the target (i.e., the center of the JWST NEP Time-Domain Field) to their intended locations within an annulus surrounding the extant HST data.</i></p>					

Proposal 16252 - treasurehunt-epoch03of13 (03) - TREASUREHUNT: Hubble's UV-Visible treasury imaging of the JWST NEP Time-...

13	(1) JWST-NEP-TDF ACS/WFC, ACCUM, WFCENTER F435W	POS TARG +58.100 ,+354.900	Sequence 1-26 Non-Int in treasurehunt-epoch03of13 (03) Prime + Parallel Group 12-14 in Sequence 1-26 Non-Int in treasurehunt-epoch03of13 (03)	1254 Secs (1254 Secs) [==>]	[2]
14	(WFC3UVI ANY S.im.1445613) WFC3/UVIS, ACCUM, UVIS F275W FLASH=11		Sequence 1-26 Non-Int in treasurehunt-epoch03of13 (03) Prime + Parallel Group 12-14 in Sequence 1-26 Non-Int in treasurehunt-epoch03of13 (03)	2731 Secs (2731 Secs) [==>]	[2]
<p>Comments: Following the June 4 2020 recommendations of J. Anderson (2020) "CURRENT CTE-MITIGATION RECOMMENDATIONS", we aim for a minimum background level of 20 e-/pix in each WFC3/UVIS F275W exposure. Taking into account the raised natural background of this pseudo-CVZ visit, the WFC3/UVIS ETC shows that this requirement becomes satisfied for FLASH=11. The APT Phase-II diagnostics seem to still test the older (now superseded) recommendation of a minimum of only 12 e-/pix, and therefore result in a warning that the specified postflash may be too high.</p>					
15	(1) JWST-NEP-TDF ACS/WFC, ACCUM, WFCENTER F435W	POS TARG +57.800 ,+355.200	Sequence 1-26 Non-Int in treasurehunt-epoch03of13 (03) Prime + Parallel Group 15-17 in Sequence 1-26 Non-Int in treasurehunt-epoch03of13 (03)	1245 Secs (1245 Secs) [==>]	[3]
<p>Comments: The specified POS_TARG values intentionally place the WFC3/UVIS and ACS/WFC instrument apertures off the coordinates of the target (i.e., the center of the JWST NEP Time-Domain Field) to their intended locations within an annulus surrounding the extant HST data.</p>					
16	(1) JWST-NEP-TDF ACS/WFC, ACCUM, WFCENTER F606W	POS TARG +57.800 ,+355.200	Sequence 1-26 Non-Int in treasurehunt-epoch03of13 (03) Prime + Parallel Group 15-17 in Sequence 1-26 Non-Int in treasurehunt-epoch03of13 (03)	1245 Secs (1245 Secs) [==>]	[3]
17	(WFC3UVI ANY S.im.1445613) WFC3/UVIS, ACCUM, UVIS F275W FLASH=11		Sequence 1-26 Non-Int in treasurehunt-epoch03of13 (03) Prime + Parallel Group 15-17 in Sequence 1-26 Non-Int in treasurehunt-epoch03of13 (03)	2714 Secs (2714 Secs) [==>]	[3]
<p>Comments: Following the June 4 2020 recommendations of J. Anderson (2020) "CURRENT CTE-MITIGATION RECOMMENDATIONS", we aim for a minimum background level of 20 e-/pix in each WFC3/UVIS F275W exposure. Taking into account the raised natural background of this pseudo-CVZ visit, the WFC3/UVIS ETC shows that this requirement becomes satisfied for FLASH=11. The APT Phase-II diagnostics seem to still test the older (now superseded) recommendation of a minimum of only 12 e-/pix, and therefore result in a warning that the specified postflash may be too high.</p>					
18	(1) JWST-NEP-TDF ACS/WFC, ACCUM, WFCENTER F606W	POS TARG +58.000 ,+355.200	Sequence 1-26 Non-Int in treasurehunt-epoch03of13 (03) Prime + Parallel Group 18-20 in Sequence 1-26 Non-Int in treasurehunt-epoch03of13 (03)	1253 Secs (1253 Secs) [==>]	[3]
<p>Comments: The specified POS_TARG values intentionally place the WFC3/UVIS and ACS/WFC instrument apertures off the coordinates of the target (i.e., the center of the JWST NEP Time-Domain Field) to their intended locations within an annulus surrounding the extant HST data.</p>					

Proposal 16252 - treasurehunt-epoch03of13 (03) - TREASUREHUNT: Hubble's UV-Visible treasury imaging of the JWST NEP Time-...

19	(1) JWST-NEP-TDF ACS/WFC, ACCUM, WFCENTER F435W	POS TARG +58.000 ,+355.200	Sequence 1-26 Non-Int in treasurehunt-epoch03of13 (03) Prime + Parallel Group 18-20 in Sequence 1-26 Non-Int in treasurehunt-epoch03of13 (03)	1254 Secs (1254 Secs) [==>]	[3]
20	(WFC3UVI ANY S.im.1445613) WFC3/UVIS, ACCUM, UVIS F275W FLASH=11		Sequence 1-26 Non-Int in treasurehunt-epoch03of13 (03) Prime + Parallel Group 18-20 in Sequence 1-26 Non-Int in treasurehunt-epoch03of13 (03)	2731 Secs (2731 Secs) [==>]	[3]
<p><i>Comments: Following the June 4 2020 recommendations of J. Anderson (2020) "CURRENT CTE-MITIGATION RECOMMENDATIONS", we aim for a minimum background level of 20 e-/pix in each WFC3/UVIS F275W exposure. Taking into account the raised natural background of this pseudo-CVZ visit, the WFC3/UVIS ETC shows that this requirement becomes satisfied for FLASH=11. The APT Phase-II diagnostics seem to still test the older (now superseded) recommendation of a minimum of only 12 e-/pix, and therefore result in a warning that the specified postflash may be too high.</i></p>					
21	(1) JWST-NEP-TDF ACS/WFC, ACCUM, WFCENTER F435W	POS TARG +57.800 ,+355.000	Sequence 1-26 Non-Int in treasurehunt-epoch03of13 (03) Prime + Parallel Group 21-23 in Sequence 1-26 Non-Int in treasurehunt-epoch03of13 (03)	994 Secs (994 Secs) [==>]	[4]
<p><i>Comments: The specified POS_TARG values intentionally place the WFC3/UVIS and ACS/WFC instrument apertures off the coordinates of the target (i.e., the center of the JWST NEP Time-Domain Field) to their intended locations within an annulus surrounding the extant HST data.</i></p>					
22	(1) JWST-NEP-TDF ACS/WFC, ACCUM, WFCENTER F606W	POS TARG +57.800 ,+355.000	Sequence 1-26 Non-Int in treasurehunt-epoch03of13 (03) Prime + Parallel Group 21-23 in Sequence 1-26 Non-Int in treasurehunt-epoch03of13 (03)	994 Secs (994 Secs) [==>]	[4]
23	(WFC3UVI ANY S.im.1445644) WFC3/UVIS, ACCUM, UVIS F275W FLASH=12		Sequence 1-26 Non-Int in treasurehunt-epoch03of13 (03) Prime + Parallel Group 21-23 in Sequence 1-26 Non-Int in treasurehunt-epoch03of13 (03)	2212 Secs (2212 Secs) [==>]	[4]
<p><i>Comments: Following the June 4 2020 recommendations of J. Anderson (2020) "CURRENT CTE-MITIGATION RECOMMENDATIONS", we aim for a minimum background level of 20 e-/pix in each WFC3/UVIS F275W exposure. Taking into account the raised natural background of this pseudo-CVZ visit, the WFC3/UVIS ETC shows that this requirement becomes satisfied for FLASH=12. The APT Phase-II diagnostics seem to still test the older (now superseded) recommendation of a minimum of only 12 e-/pix, and therefore result in a warning that the specified postflash may be too high.</i></p>					
24	(1) JWST-NEP-TDF ACS/WFC, ACCUM, WFCENTER F606W	POS TARG +58.000 ,+355.000	Sequence 1-26 Non-Int in treasurehunt-epoch03of13 (03) Prime + Parallel Group 24-26 in Sequence 1-26 Non-Int in treasurehunt-epoch03of13 (03)	997 Secs (997 Secs) [==>]	[4]
<p><i>Comments: The specified POS_TARG values intentionally place the WFC3/UVIS and ACS/WFC instrument apertures off the coordinates of the target (i.e., the center of the JWST NEP Time-Domain Field) to their intended locations within an annulus surrounding the extant HST data.</i></p>					

Proposal 16252 - treasurehunt-epoch03of13 (03) - TREASUREHUNT: Hubble's UV-Visible treasury imaging of the JWST NEP Time-...

25	(1) JWST-NEP-TDF ACS/WFC, ACCUM, WFCENTER F435W	POS TARG +58.000 ,+355.000	Sequence 1-26 Non-Int in treasurehunt-epoch03of13 (03)  Prime + Parallel Group 24-26 in Sequence 1-26 Non-Int in treasurehunt-epoch03of13 (03)	997 Secs (997 Secs) [==>]	[4]
26	(WFC3UVI ANY S.im.144564 4) WFC3/UVIS, ACCUM, UVIS F275W FLASH=12		Sequence 1-26 Non-Int in treasurehunt-epoch03of13 (03)  Prime + Parallel Group 24-26 in Sequence 1-26 Non-Int in treasurehunt-epoch03of13 (03)	2198 Secs (2198 Secs) [==>]	[4]
<p><i>Comments: Following the June 4 2020 recommendations of J. Anderson (2020) "CURRENT CTE-MITIGATION RECOMMENDATIONS", we aim for a minimum background level of 20 e-/pix in each WFC3/UVIS F275W exposure. Taking into account the raised natural background of this pseudo-CVZ visit, the WFC3/UVIS ETC shows that this requirement becomes satisfied for FLASH=12. The APT Phase-II diagnostics seem to still test the older (now superseded) recommendation of a minimum of only 12 e-/pix, and therefore result in a warning that the specified postflash may be too high.</i></p>					

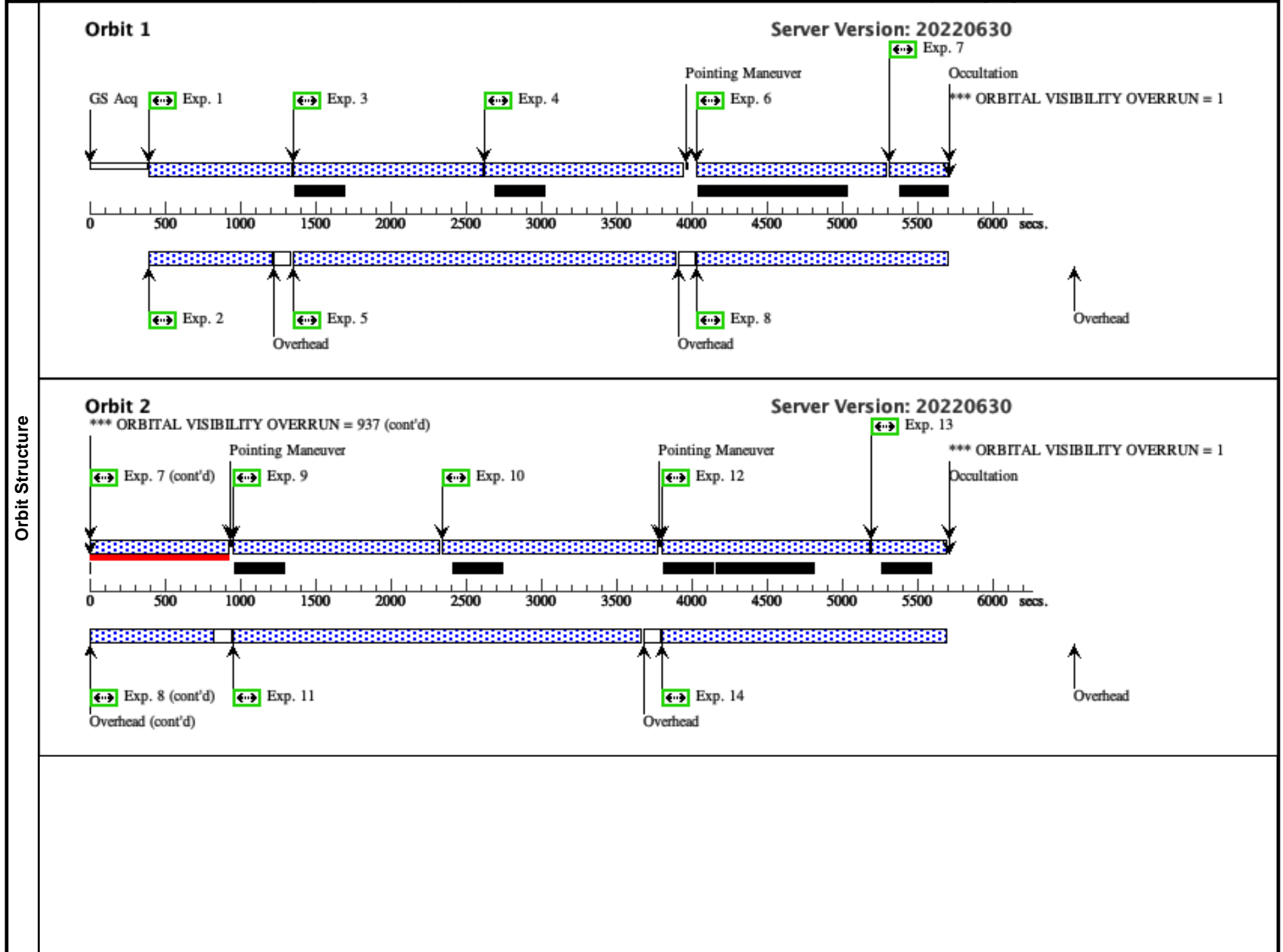

**Orbit 3**

\*\*\* ORBITAL VISIBILITY OVERRUN = 937 (cont'd)

Server Version: 20220630

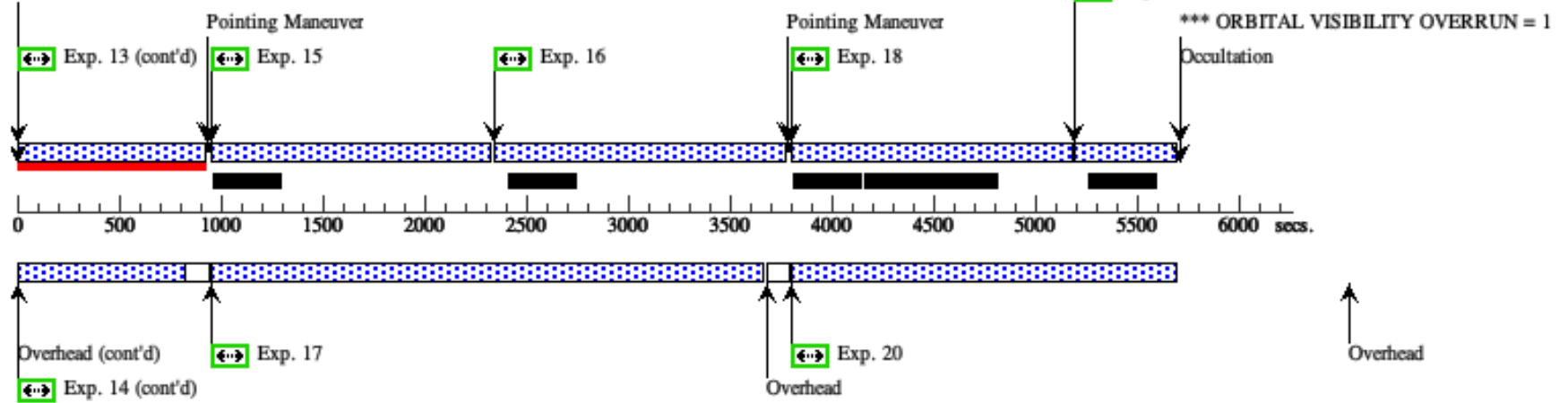

**Orbit 4**

\*\*\* ORBITAL VISIBILITY OVERRUN = 937 (cont'd)

Server Version: 20220630

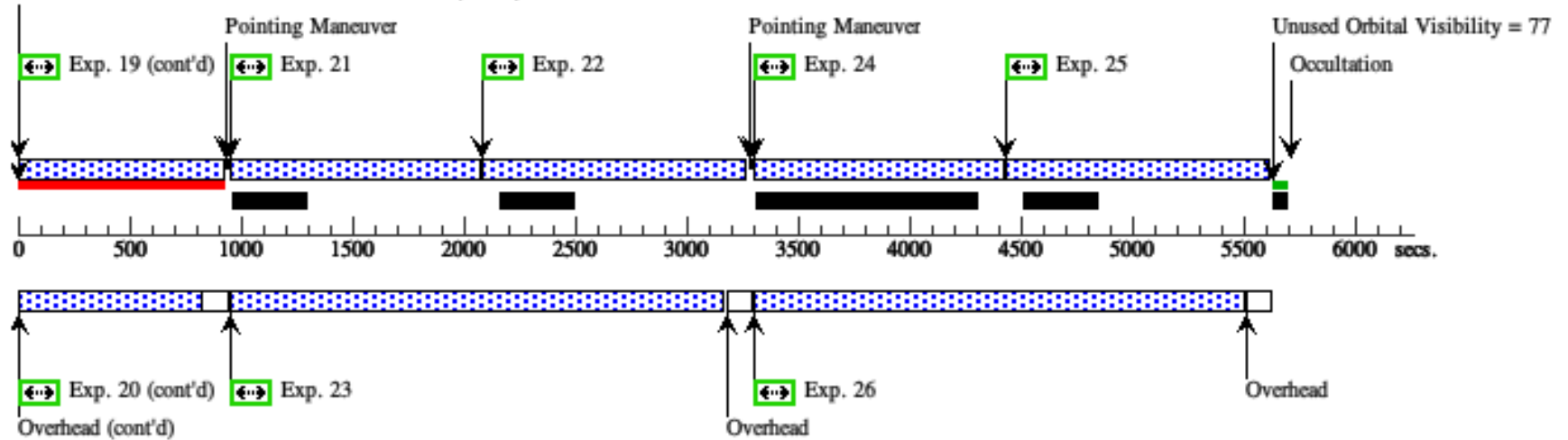

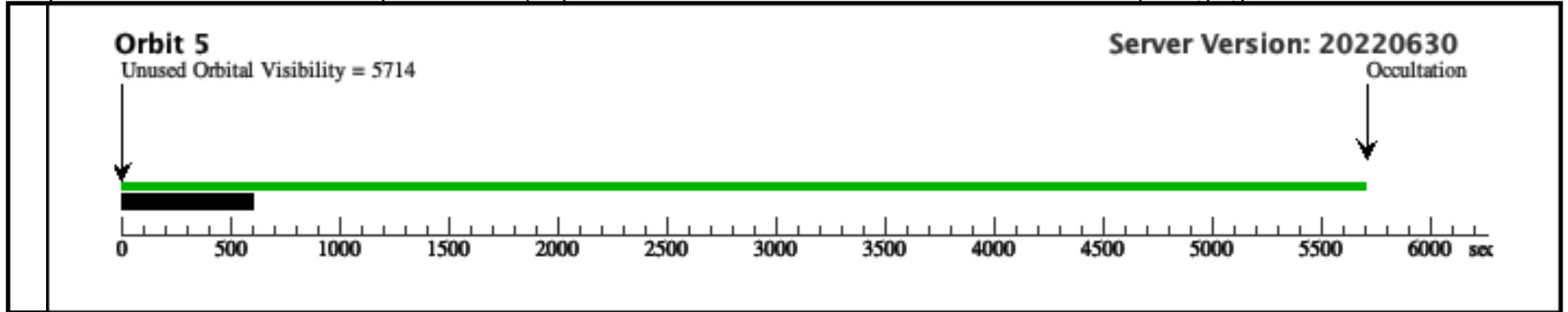



Proposal 16252 - treasurehunt-epoch04of13 (04) - TREASUREHUNT: Hubble's UV-Visible treasury imaging of the JWST NEP Time...

#	Label (ETC Run)	Target	Config,Mode,Aperture	Spectral Els.	Opt. Params.	Special Reqs.	Groups	Exp. Time (Total)/[Actual Dur.]	Orbit
1		(1) JWST-NEP-TDF	ACS/WFC, ACCUM, WFCENTER	F435W		POS TARG +44.900 ,+375.100	Sequence 1-24 Non-Int in treasurehunt-epoch04of13 (04)  Prime + Parallel Group 1-3 in Sequence 1-24 Non-Int in treasurehunt-epoch04of13 (04)	1136 Secs (1136 Secs) [==>]	[1]
<p><i>Comments: The specified POS_TARG values intentionally place the WFC3/UVIS and ACS/WFC instrument apertures off the coordinates of the target (i.e., the center of the JWST NEP Time-Domain Field) to their intended locations within an annulus surrounding the extant HST data.</i></p>									
2		(1) JWST-NEP-TDF	ACS/WFC, ACCUM, WFCENTER	F606W		POS TARG +44.900 ,+375.100	Sequence 1-24 Non-Int in treasurehunt-epoch04of13 (04)  Prime + Parallel Group 1-3 in Sequence 1-24 Non-Int in treasurehunt-epoch04of13 (04)	1136 Secs (1136 Secs) [==>]	[1]
3	(WFC3UVIS.im.1445613)	ANY	WFC3/UVIS, ACCUM, UVIS	F275W	FLASH=11		Sequence 1-24 Non-Int in treasurehunt-epoch04of13 (04)  Prime + Parallel Group 1-3 in Sequence 1-24 Non-Int in treasurehunt-epoch04of13 (04)	2545 Secs (2545 Secs) [==>]	[1]
<p><i>Comments: Following the June 4 2020 recommendations of J. Anderson (2020) "CURRENT CTE-MITIGATION RECOMMENDATIONS", we aim for a minimum background level of 20 e-/pix in each WFC3/UVIS F275W exposure. Taking into account the raised natural background of this pseudo-CVZ visit, the WFC3/UVIS ETC shows that this requirement becomes satisfied for FLASH=11. The APT Phase-II diagnostics seem to still test the older (now superseded) recommendation of a minimum of only 12 e-/pix, and therefore result in a warning that the specified postflash may be too high.</i></p>									
4		(1) JWST-NEP-TDF	ACS/WFC, ACCUM, WFCENTER	F606W		POS TARG +45.100 ,+375.100	Sequence 1-24 Non-Int in treasurehunt-epoch04of13 (04)  Prime + Parallel Group 4-6 in Sequence 1-24 Non-Int in treasurehunt-epoch04of13 (04)	1140 Secs (1140 Secs) [==>]	[1]
<p><i>Comments: The specified POS_TARG values intentionally place the WFC3/UVIS and ACS/WFC instrument apertures off the coordinates of the target (i.e., the center of the JWST NEP Time-Domain Field) to their intended locations within an annulus surrounding the extant HST data.</i></p>									
5		(1) JWST-NEP-TDF	ACS/WFC, ACCUM, WFCENTER	F435W		POS TARG +45.100 ,+375.100	Sequence 1-24 Non-Int in treasurehunt-epoch04of13 (04)  Prime + Parallel Group 4-6 in Sequence 1-24 Non-Int in treasurehunt-epoch04of13 (04)	1140 Secs (1140 Secs) [==>]	[1]

Exposures

Proposal 16252 - treasurehunt-epoch04of13 (04) - TREASUREHUNT: Hubble's UV-Visible treasury imaging of the JWST NEP Time...

6	(WFC3UVI ANY S.im.1445613)	WFC3/UVIS, ACCUM, UVIS	F275W	FLASH=11		Sequence 1-24 Non-Int in treasurehunt-epoch04of13 (04) Prime + Parallel Group 4-6 in Sequence 1-24 Non-Int in treasurehunt-epoch04of13 (04)	2504 Secs (2504 Secs) [==>]	[1]
<p>Comments: Following the June 4 2020 recommendations of J. Anderson (2020) "CURRENT CTE-MITIGATION RECOMMENDATIONS", we aim for a minimum background level of 20 e-/pix in each WFC3/UVIS F275W exposure. Taking into account the raised natural background of this pseudo-CVZ visit, the WFC3/UVIS ETC shows that this requirement becomes satisfied for FLASH=11. The APT Phase-II diagnostics seem to still test the older (now superseded) recommendation of a minimum of only 12 e-/pix, and therefore result in a warning that the specified postflash may be too high.</p>								
7	(1) JWST-NEP-TDF	ACS/WFC, ACCUM, WFCENTER	F435W		POS TARG +44.900, +374.900	Sequence 1-24 Non-Int in treasurehunt-epoch04of13 (04) Prime + Parallel Group 7-9 in Sequence 1-24 Non-Int in treasurehunt-epoch04of13 (04)	1245 Secs (1245 Secs) [==>]	[2]
<p>Comments: The specified POS_TARG values intentionally place the WFC3/UVIS and ACS/WFC instrument apertures off the coordinates of the target (i.e., the center of the JWST NEP Time-Domain Field) to their intended locations within an annulus surrounding the extant HST data.</p>								
8	(1) JWST-NEP-TDF	ACS/WFC, ACCUM, WFCENTER	F606W		POS TARG +44.900, +374.900	Sequence 1-24 Non-Int in treasurehunt-epoch04of13 (04) Prime + Parallel Group 7-9 in Sequence 1-24 Non-Int in treasurehunt-epoch04of13 (04)	1245 Secs (1245 Secs) [==>]	[2]
9	(WFC3UVI ANY S.im.1445613)	WFC3/UVIS, ACCUM, UVIS	F275W	FLASH=11		Sequence 1-24 Non-Int in treasurehunt-epoch04of13 (04) Prime + Parallel Group 7-9 in Sequence 1-24 Non-Int in treasurehunt-epoch04of13 (04)	2714 Secs (2714 Secs) [==>]	[2]
<p>Comments: Following the June 4 2020 recommendations of J. Anderson (2020) "CURRENT CTE-MITIGATION RECOMMENDATIONS", we aim for a minimum background level of 20 e-/pix in each WFC3/UVIS F275W exposure. Taking into account the raised natural background of this pseudo-CVZ visit, the WFC3/UVIS ETC shows that this requirement becomes satisfied for FLASH=11. The APT Phase-II diagnostics seem to still test the older (now superseded) recommendation of a minimum of only 12 e-/pix, and therefore result in a warning that the specified postflash may be too high.</p>								
10	(1) JWST-NEP-TDF	ACS/WFC, ACCUM, WFCENTER	F606W		POS TARG +45.100, +374.900	Sequence 1-24 Non-Int in treasurehunt-epoch04of13 (04) Prime + Parallel Group 10-12 in Sequence 1-24 Non-Int in treasurehunt-epoch04of13 (04)	1253 Secs (1253 Secs) [==>]	[2]
<p>Comments: The specified POS_TARG values intentionally place the WFC3/UVIS and ACS/WFC instrument apertures off the coordinates of the target (i.e., the center of the JWST NEP Time-Domain Field) to their intended locations within an annulus surrounding the extant HST data.</p>								
11	(1) JWST-NEP-TDF	ACS/WFC, ACCUM, WFCENTER	F435W		POS TARG +45.100, +374.900	Sequence 1-24 Non-Int in treasurehunt-epoch04of13 (04) Prime + Parallel Group 10-12 in Sequence 1-24 Non-Int in treasurehunt-epoch04of13 (04)	1254 Secs (1254 Secs) [==>]	[2]

Proposal 16252 - treasurehunt-epoch04of13 (04) - TREASUREHUNT: Hubble's UV-Visible treasury imaging of the JWST NEP Time...

12	(WFC3UVI ANY S.im.1445613)	WFC3/UVIS, ACCUM, UVIS	F275W	FLASH=11		Sequence 1-24 Non-Int in treasurehunt-epoch04of13 (04) Prime + Parallel Group 10-12 in Sequence 1-24 Non-Int in treasurehunt-epoch04of13 (04)	2731 Secs (2731 Secs) [==>]	[2]
<p>Comments: Following the June 4 2020 recommendations of J. Anderson (2020) "CURRENT CTE-MITIGATION RECOMMENDATIONS", we aim for a minimum background level of 20 e-/pix in each WFC3/UVIS F275W exposure. Taking into account the raised natural background of this pseudo-CVZ visit, the WFC3/UVIS ETC shows that this requirement becomes satisfied for FLASH=11. The APT Phase-II diagnostics seem to still test the older (now superseded) recommendation of a minimum of only 12 e-/pix, and therefore result in a warning that the specified postflash may be too high.</p>								
13	(1) JWST-NEP-TDF	ACS/WFC, ACCUM, WFCENTER	F435W		POS TARG +44.800, +375.200	Sequence 1-24 Non-Int in treasurehunt-epoch04of13 (04) Prime + Parallel Group 13-15 in Sequence 1-24 Non-Int in treasurehunt-epoch04of13 (04)	1245 Secs (1245 Secs) [==>]	[3]
<p>Comments: The specified POS_TARG values intentionally place the WFC3/UVIS and ACS/WFC instrument apertures off the coordinates of the target (i.e., the center of the JWST NEP Time-Domain Field) to their intended locations within an annulus surrounding the extant HST data.</p>								
14	(1) JWST-NEP-TDF	ACS/WFC, ACCUM, WFCENTER	F606W		POS TARG +44.800, +375.200	Sequence 1-24 Non-Int in treasurehunt-epoch04of13 (04) Prime + Parallel Group 13-15 in Sequence 1-24 Non-Int in treasurehunt-epoch04of13 (04)	1245 Secs (1245 Secs) [==>]	[3]
15	(WFC3UVI ANY S.im.1445613)	WFC3/UVIS, ACCUM, UVIS	F275W	FLASH=11		Sequence 1-24 Non-Int in treasurehunt-epoch04of13 (04) Prime + Parallel Group 13-15 in Sequence 1-24 Non-Int in treasurehunt-epoch04of13 (04)	2714 Secs (2714 Secs) [==>]	[3]
<p>Comments: Following the June 4 2020 recommendations of J. Anderson (2020) "CURRENT CTE-MITIGATION RECOMMENDATIONS", we aim for a minimum background level of 20 e-/pix in each WFC3/UVIS F275W exposure. Taking into account the raised natural background of this pseudo-CVZ visit, the WFC3/UVIS ETC shows that this requirement becomes satisfied for FLASH=11. The APT Phase-II diagnostics seem to still test the older (now superseded) recommendation of a minimum of only 12 e-/pix, and therefore result in a warning that the specified postflash may be too high.</p>								
16	(1) JWST-NEP-TDF	ACS/WFC, ACCUM, WFCENTER	F606W		POS TARG +45.000, +375.200	Sequence 1-24 Non-Int in treasurehunt-epoch04of13 (04) Prime + Parallel Group 16-18 in Sequence 1-24 Non-Int in treasurehunt-epoch04of13 (04)	1253 Secs (1253 Secs) [==>]	[3]
<p>Comments: The specified POS_TARG values intentionally place the WFC3/UVIS and ACS/WFC instrument apertures off the coordinates of the target (i.e., the center of the JWST NEP Time-Domain Field) to their intended locations within an annulus surrounding the extant HST data.</p>								
17	(1) JWST-NEP-TDF	ACS/WFC, ACCUM, WFCENTER	F435W		POS TARG +45.000, +375.200	Sequence 1-24 Non-Int in treasurehunt-epoch04of13 (04) Prime + Parallel Group 16-18 in Sequence 1-24 Non-Int in treasurehunt-epoch04of13 (04)	1254 Secs (1254 Secs) [==>]	[3]

Proposal 16252 - treasurehunt-epoch04of13 (04) - TREASUREHUNT: Hubble's UV-Visible treasury imaging of the JWST NEP Time...

18	(WFC3UVI ANY S.im.1445613)	WFC3/UVIS, ACCUM, UVIS	F275W	FLASH=11		Sequence 1-24 Non-Int in treasurehunt-epoch04of13 (04) Prime + Parallel Group 16-18 in Sequence 1-24 Non-Int in treasurehunt-epoch04of13 (04)	2731 Secs (2731 Secs) [==>]	[3]
<p>Comments: Following the June 4 2020 recommendations of J. Anderson (2020) "CURRENT CTE-MITIGATION RECOMMENDATIONS", we aim for a minimum background level of 20 e-/pix in each WFC3/UVIS F275W exposure. Taking into account the raised natural background of this pseudo-CVZ visit, the WFC3/UVIS ETC shows that this requirement becomes satisfied for FLASH=11. The APT Phase-II diagnostics seem to still test the older (now superseded) recommendation of a minimum of only 12 e-/pix, and therefore result in a warning that the specified postflash may be too high.</p>								
19	(1) JWST-NEP-TDF	ACS/WFC, ACCUM, WFCENTER	F435W		POS TARG +44.800, +375.000	Sequence 1-24 Non-Int in treasurehunt-epoch04of13 (04) Prime + Parallel Group 19-21 in Sequence 1-24 Non-Int in treasurehunt-epoch04of13 (04)	994 Secs (994 Secs) [==>]	[4]
<p>Comments: The specified POS_TARG values intentionally place the WFC3/UVIS and ACS/WFC instrument apertures off the coordinates of the target (i.e., the center of the JWST NEP Time-Domain Field) to their intended locations within an annulus surrounding the extant HST data.</p>								
20	(1) JWST-NEP-TDF	ACS/WFC, ACCUM, WFCENTER	F606W		POS TARG +44.800, +375.000	Sequence 1-24 Non-Int in treasurehunt-epoch04of13 (04) Prime + Parallel Group 19-21 in Sequence 1-24 Non-Int in treasurehunt-epoch04of13 (04)	994 Secs (994 Secs) [==>]	[4]
21	(WFC3UVI ANY S.im.1445644)	WFC3/UVIS, ACCUM, UVIS	F275W	FLASH=12		Sequence 1-24 Non-Int in treasurehunt-epoch04of13 (04) Prime + Parallel Group 19-21 in Sequence 1-24 Non-Int in treasurehunt-epoch04of13 (04)	2212 Secs (2212 Secs) [==>]	[4]
<p>Comments: Following the June 4 2020 recommendations of J. Anderson (2020) "CURRENT CTE-MITIGATION RECOMMENDATIONS", we aim for a minimum background level of 20 e-/pix in each WFC3/UVIS F275W exposure. Taking into account the raised natural background of this pseudo-CVZ visit, the WFC3/UVIS ETC shows that this requirement becomes satisfied for FLASH=12. The APT Phase-II diagnostics seem to still test the older (now superseded) recommendation of a minimum of only 12 e-/pix, and therefore result in a warning that the specified postflash may be too high.</p>								
22	(1) JWST-NEP-TDF	ACS/WFC, ACCUM, WFCENTER	F606W		POS TARG +45.000, +375.000	Sequence 1-24 Non-Int in treasurehunt-epoch04of13 (04) Prime + Parallel Group 22-24 in Sequence 1-24 Non-Int in treasurehunt-epoch04of13 (04)	997 Secs (997 Secs) [==>]	[4]
<p>Comments: The specified POS_TARG values intentionally place the WFC3/UVIS and ACS/WFC instrument apertures off the coordinates of the target (i.e., the center of the JWST NEP Time-Domain Field) to their intended locations within an annulus surrounding the extant HST data.</p>								
23	(1) JWST-NEP-TDF	ACS/WFC, ACCUM, WFCENTER	F435W		POS TARG +45.000, +375.000	Sequence 1-24 Non-Int in treasurehunt-epoch04of13 (04) Prime + Parallel Group 22-24 in Sequence 1-24 Non-Int in treasurehunt-epoch04of13 (04)	997 Secs (997 Secs) [==>]	[4]

Proposal 16252 - treasurehunt-epoch04of13 (04) - TREASUREHUNT: Hubble's UV-Visible treasury imaging of the JWST NEP Time-...

24	(WFC3UVI ANY S.im.144564 4)	WFC3/UVIS, ACCUM, UVIS	F275W	FLASH=12	Sequence 1-24 Non-Int in treasurehunt-epoch04of13 (04)  Prime + Parallel Group 22-24 in Sequence 1-24 Non-Int in treasurehunt-epoch04of13 (04)	2198 Secs (2198 Secs)  [==>]	[4]
<p><i>Comments: Following the June 4 2020 recommendations of J. Anderson (2020) "CURRENT CTE-MITIGATION RECOMMENDATIONS", we aim for a minimum background level of 20 e-/pix in each WFC3/UVIS F275W exposure. Taking into account the raised natural background of this pseudo-CVZ visit, the WFC3/UVIS ETC shows that this requirement becomes satisfied for FLASH=12. The APT Phase-II diagnostics seem to still test the older (now superseded) recommendation of a minimum of only 12 e-/pix, and therefore result in a warning that the specified postflash may be too high.</i></p>							

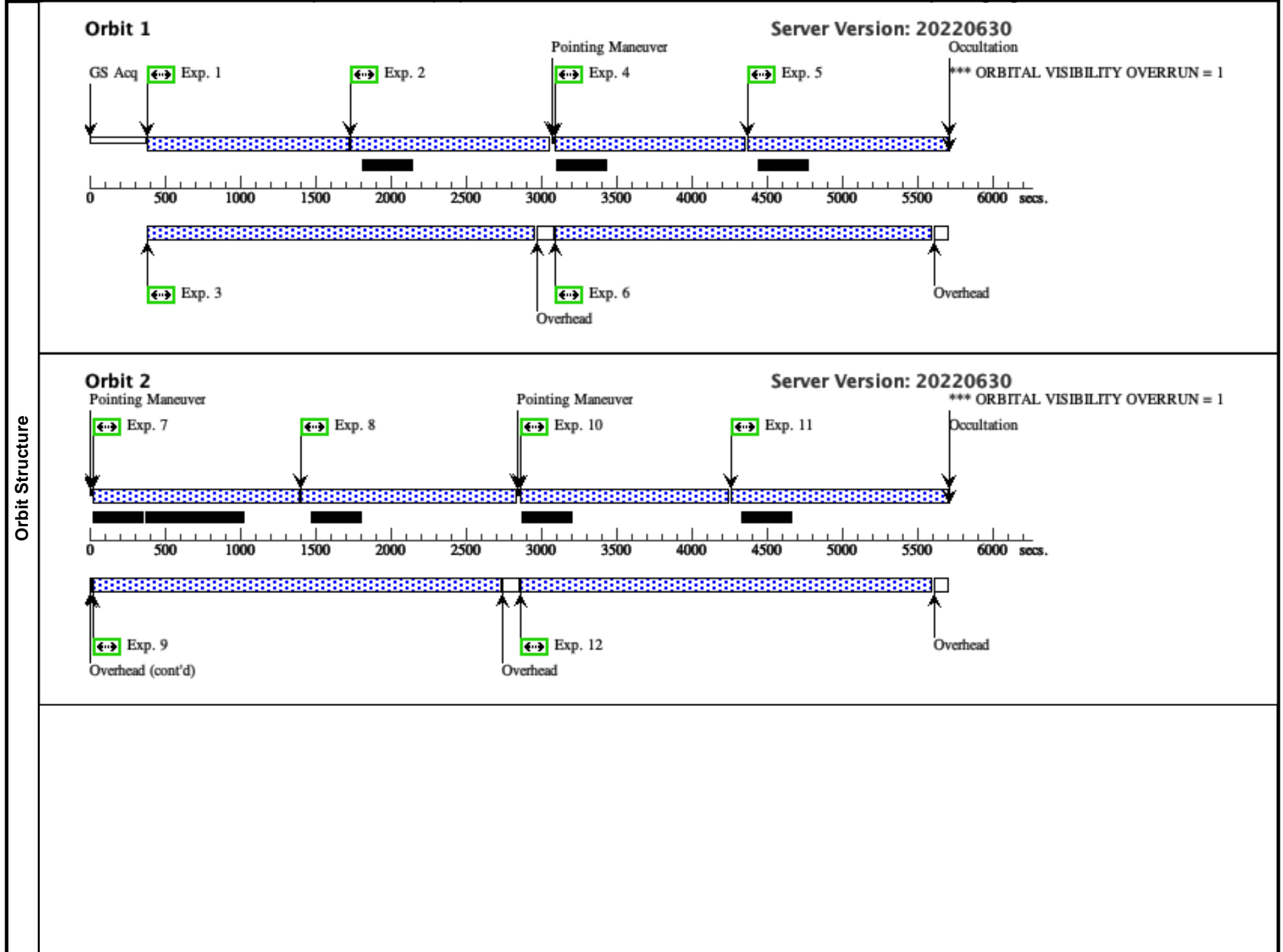

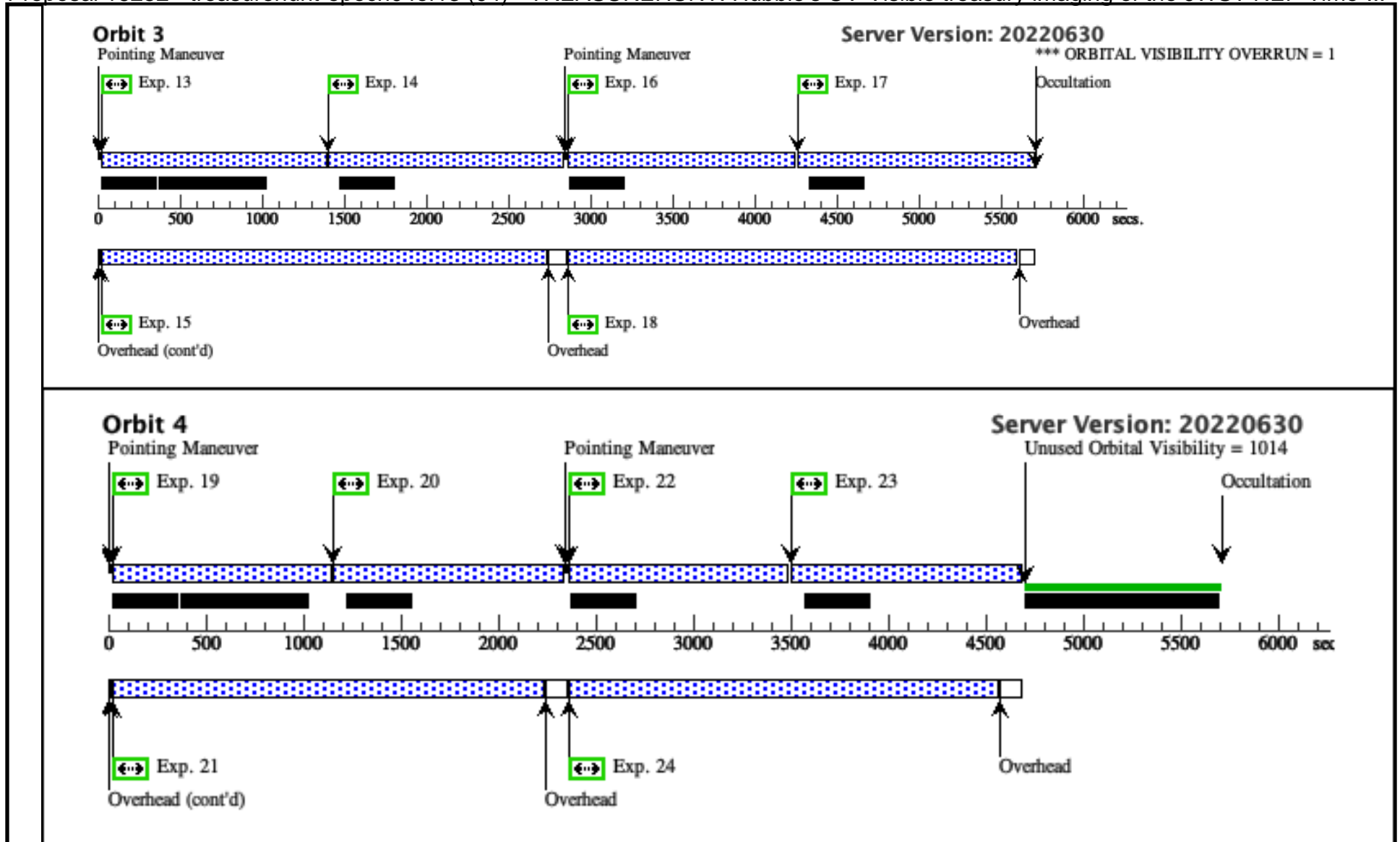



Proposal 16252 - treasurehunt-epoch04of13 (A4) - TREASUREHUNT: Hubble's UV-Visible treasury imaging of the JWST NEP Time...

#	Label	Target	Config,Mode,Aperture	Spectral Els.	Opt. Params.	Special Reqs.	Groups	Exp. Time (Total)/[Actual Dur.]	Orbit
1		(1) JWST-NEP-TDF	ACS/WFC, ACCUM, WFCENTER	F435W		POS TARG +44.900 ,+375.100	Sequence 1-16 Non-Int in treasurehunt-epoch04of13 (A4)	1136 Secs (1136 Secs) [==>]	[1]
<i>Comments: The specified POS_TARG values intentionally place the WFC3/UVIS and ACS/WFC instrument apertures off the coordinates of the target (i.e., the center of the JWST NEP Time-Domain Field) to their intended locations within an annulus surrounding the extant HST data.</i>									
2		(1) JWST-NEP-TDF	ACS/WFC, ACCUM, WFCENTER	F606W		POS TARG +44.900 ,+375.100	Sequence 1-16 Non-Int in treasurehunt-epoch04of13 (A4)	1136 Secs (1136 Secs) [==>]	[1]
3		(1) JWST-NEP-TDF	ACS/WFC, ACCUM, WFCENTER	F606W		POS TARG +45.100 ,+375.100	Sequence 1-16 Non-Int in treasurehunt-epoch04of13 (A4)	1140 Secs (1140 Secs) [==>]	[2]
<i>Comments: The specified POS_TARG values intentionally place the WFC3/UVIS and ACS/WFC instrument apertures off the coordinates of the target (i.e., the center of the JWST NEP Time-Domain Field) to their intended locations within an annulus surrounding the extant HST data.</i>									
4		(1) JWST-NEP-TDF	ACS/WFC, ACCUM, WFCENTER	F435W		POS TARG +45.100 ,+375.100	Sequence 1-16 Non-Int in treasurehunt-epoch04of13 (A4)	1140 Secs (1140 Secs) [==>]	[2]
5		(1) JWST-NEP-TDF	ACS/WFC, ACCUM, WFCENTER	F435W		POS TARG +44.900 ,+374.900	Sequence 1-16 Non-Int in treasurehunt-epoch04of13 (A4)	1245 Secs (1245 Secs) [==>]	[2]
<i>Comments: The specified POS_TARG values intentionally place the WFC3/UVIS and ACS/WFC instrument apertures off the coordinates of the target (i.e., the center of the JWST NEP Time-Domain Field) to their intended locations within an annulus surrounding the extant HST data.</i>									
6		(1) JWST-NEP-TDF	ACS/WFC, ACCUM, WFCENTER	F606W		POS TARG +44.900 ,+374.900	Sequence 1-16 Non-Int in treasurehunt-epoch04of13 (A4)	1245 Secs (1245 Secs) [==>]	[2]
7		(1) JWST-NEP-TDF	ACS/WFC, ACCUM, WFCENTER	F606W		POS TARG +45.100 ,+374.900	Sequence 1-16 Non-Int in treasurehunt-epoch04of13 (A4)	1253 Secs (1253 Secs) [==>]	[3]
<i>Comments: The specified POS_TARG values intentionally place the WFC3/UVIS and ACS/WFC instrument apertures off the coordinates of the target (i.e., the center of the JWST NEP Time-Domain Field) to their intended locations within an annulus surrounding the extant HST data.</i>									
8		(1) JWST-NEP-TDF	ACS/WFC, ACCUM, WFCENTER	F435W		POS TARG +45.100 ,+374.900	Sequence 1-16 Non-Int in treasurehunt-epoch04of13 (A4)	1254 Secs (1254 Secs) [==>]	[3]
9		(1) JWST-NEP-TDF	ACS/WFC, ACCUM, WFCENTER	F435W		POS TARG +44.800 ,+375.200	Sequence 1-16 Non-Int in treasurehunt-epoch04of13 (A4)	1245 Secs (1245 Secs) [==>]	[3]
<i>Comments: The specified POS_TARG values intentionally place the WFC3/UVIS and ACS/WFC instrument apertures off the coordinates of the target (i.e., the center of the JWST NEP Time-Domain Field) to their intended locations within an annulus surrounding the extant HST data.</i>									
10		(1) JWST-NEP-TDF	ACS/WFC, ACCUM, WFCENTER	F606W		POS TARG +44.800 ,+375.200	Sequence 1-16 Non-Int in treasurehunt-epoch04of13 (A4)	1245 Secs (1245 Secs) [==>]	[3]
11		(1) JWST-NEP-TDF	ACS/WFC, ACCUM, WFCENTER	F606W		POS TARG +45.000 ,+375.200	Sequence 1-16 Non-Int in treasurehunt-epoch04of13 (A4)	1253 Secs (1253 Secs) [==>]	[4]
<i>Comments: The specified POS_TARG values intentionally place the WFC3/UVIS and ACS/WFC instrument apertures off the coordinates of the target (i.e., the center of the JWST NEP Time-Domain Field) to their intended locations within an annulus surrounding the extant HST data.</i>									
12		(1) JWST-NEP-TDF	ACS/WFC, ACCUM, WFCENTER	F435W		POS TARG +45.000 ,+375.200	Sequence 1-16 Non-Int in treasurehunt-epoch04of13 (A4)	1254 Secs (1254 Secs) [==>]	[4]
13		(1) JWST-NEP-TDF	ACS/WFC, ACCUM, WFCENTER	F435W		POS TARG +44.800 ,+375.000	Sequence 1-16 Non-Int in treasurehunt-epoch04of13 (A4)	994 Secs (994 Secs) [==>]	[4]
<i>Comments: The specified POS_TARG values intentionally place the WFC3/UVIS and ACS/WFC instrument apertures off the coordinates of the target (i.e., the center of the JWST NEP Time-Domain Field) to their intended locations within an annulus surrounding the extant HST data.</i>									

Exposures

Proposal 16252 - treasurehunt-epoch04of13 (A4) - TREASUREHUNT: Hubble's UV-Visible treasury imaging of the JWST NEP Time...

14	(1) JWST-NEP-TDF ACS/WFC, ACCUM, WFCENTER F606W	POS TARG +44.800 ,+375.000	Sequence 1-16 Non-Int in treasurehunt-epoch04of13 (A4)	994 Secs (994 Secs) [==>]	[4]
15	(1) JWST-NEP-TDF ACS/WFC, ACCUM, WFCENTER F606W	POS TARG +45.000 ,+375.000	Sequence 1-16 Non-Int in treasurehunt-epoch04of13 (A4)	997 Secs (997 Secs) [==>]	[4]
<i>Comments: The specified POS_TARG values intentionally place the WFC3/UVIS and ACS/WFC instrument apertures off the coordinates of the target (i.e., the center of the JWST NEP Time-Domain Field) to their intended locations within an annulus surrounding the extant HST data.</i>					
16	(1) JWST-NEP-TDF ACS/WFC, ACCUM, WFCENTER F435W	POS TARG +45.000 ,+375.000	Sequence 1-16 Non-Int in treasurehunt-epoch04of13 (A4)	997 Secs (997 Secs) [==>]	[5]

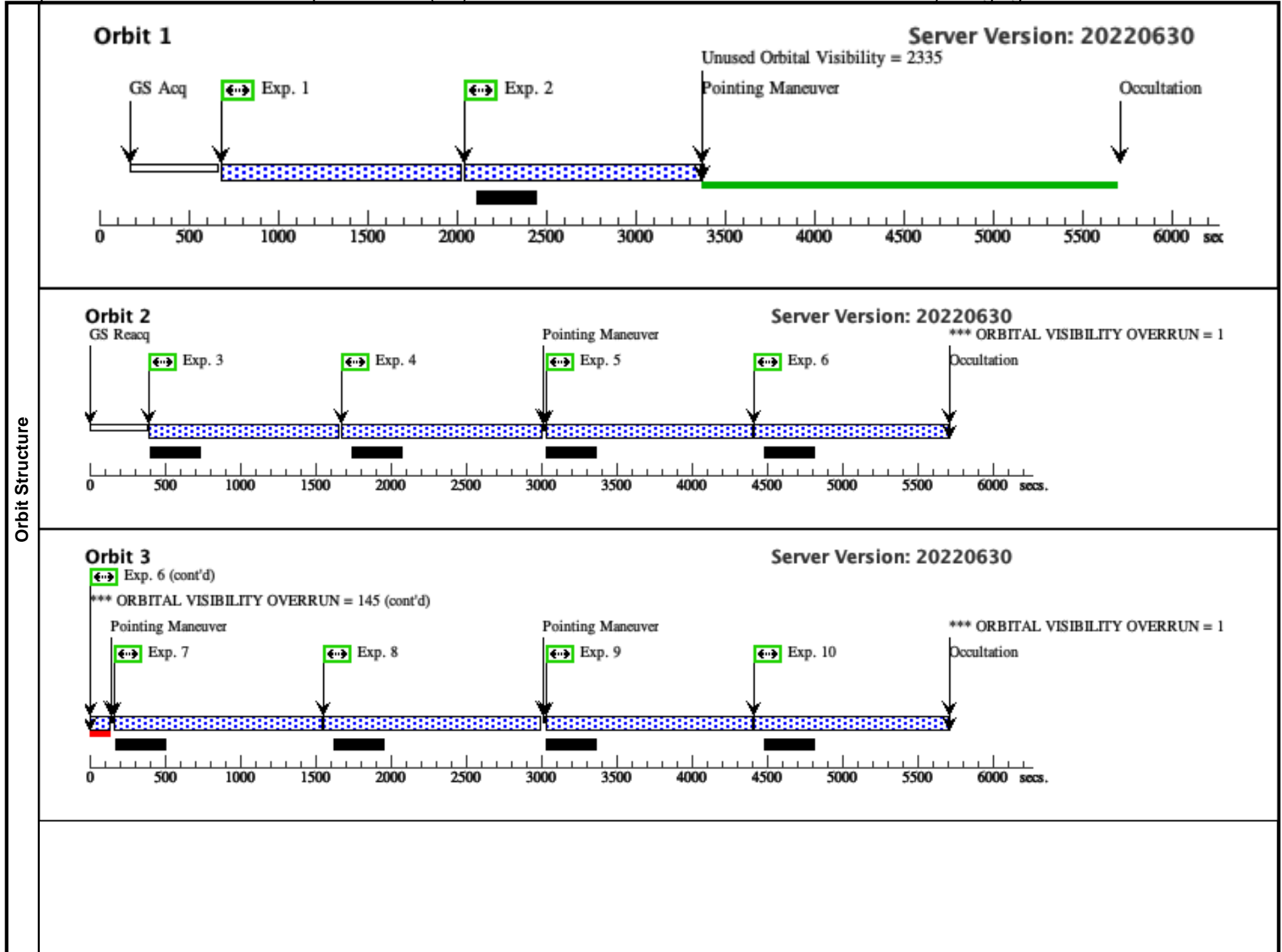

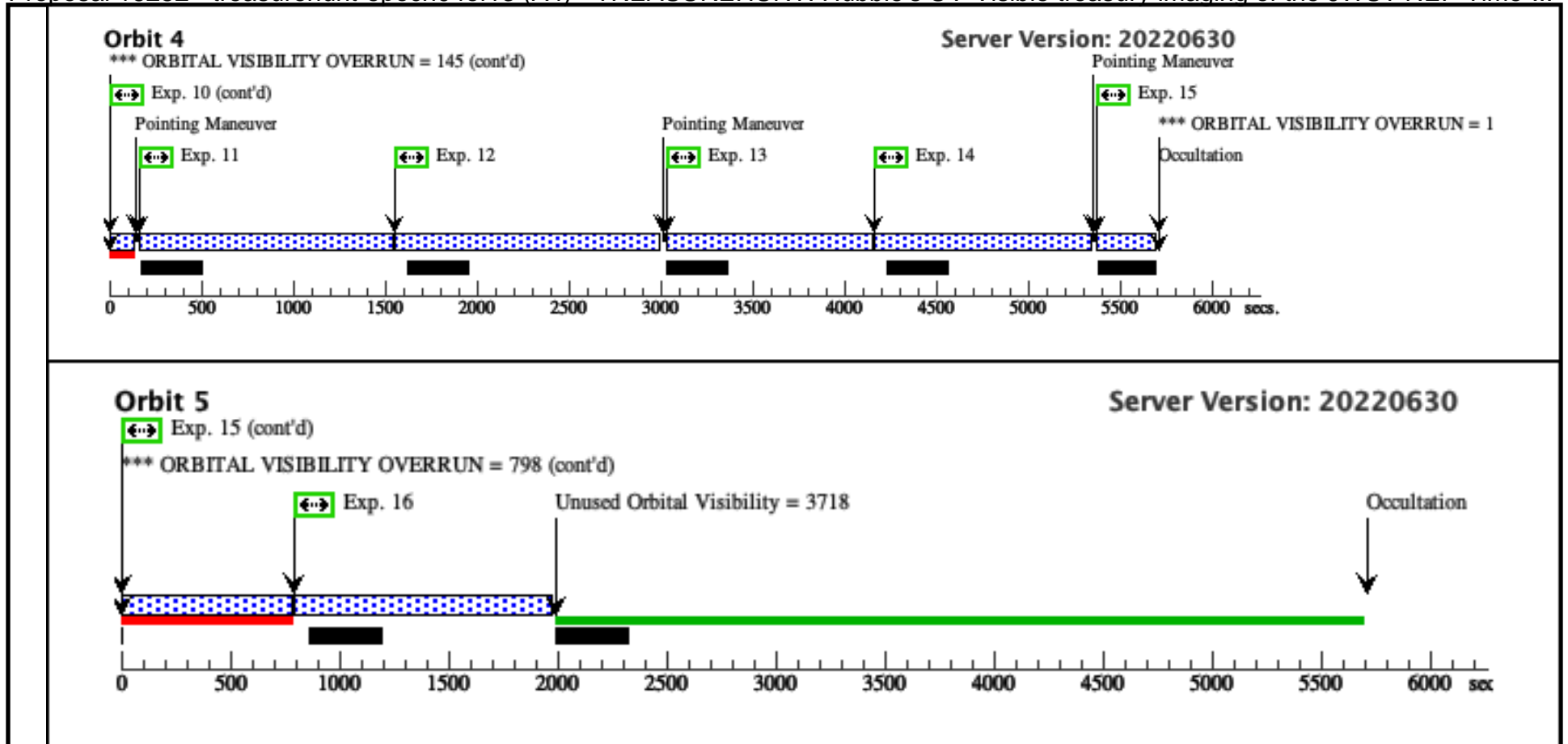



Proposal 16252 - treasurehunt-epoch05of13 (05) - TREASUREHUNT: Hubble's UV-Visible treasury imaging of the JWST NEP Time-...

#	Label (ETC Run)	Target	Config,Mode,Aperture	Spectral Els.	Opt. Params.	Special Reqs.	Groups	Exp. Time (Total)/[Actual Dur.]	Orbit
1		(1) JWST-NEP-TDF	ACS/WFC, ACCUM, WFCENTER	F435W		POS TARG 44.9,365.1	Sequence 1-26 Non-Int in treasurehunt-epoch05of13 (05) Prime + Parallel Group 1-2 in Sequence 1-26 Non-Int in treasurehunt-epoch05of13 (05)	500 Secs (500 Secs) [==>]	[1]
2		ANY	WFC3/UVIS, ACCUM, UVIS	F275W	FLASH=19		Sequence 1-26 Non-Int in treasurehunt-epoch05of13 (05) Prime + Parallel Group 1-2 in Sequence 1-26 Non-Int in treasurehunt-epoch05of13 (05)	550 Secs (550 Secs) [==>]	[1]
3		(1) JWST-NEP-TDF	ACS/WFC, ACCUM, WFCENTER	F435W		POS TARG +44.900, +365.100	Sequence 1-26 Non-Int in treasurehunt-epoch05of13 (05) Prime + Parallel Group 3-5 in Sequence 1-26 Non-Int in treasurehunt-epoch05of13 (05)	1217 Secs (1217 Secs) [==>]	[1]
<p><i>Comments: The specified POS_TARG values intentionally place the WFC3/UVIS and ACS/WFC instrument apertures off the coordinates of the target (i.e., the center of the JWST NEP Time-Domain Field) to their intended locations within an annulus surrounding the extant HST data.</i></p>									
4		(1) JWST-NEP-TDF	ACS/WFC, ACCUM, WFCENTER	F606W		POS TARG +44.900, +365.100	Sequence 1-26 Non-Int in treasurehunt-epoch05of13 (05) Prime + Parallel Group 3-5 in Sequence 1-26 Non-Int in treasurehunt-epoch05of13 (05)	1136 Secs (1136 Secs) [==>]	[1]
5	(WFC3UVIS.im.1445613)	ANY	WFC3/UVIS, ACCUM, UVIS	F275W	FLASH=11		Sequence 1-26 Non-Int in treasurehunt-epoch05of13 (05) Prime + Parallel Group 3-5 in Sequence 1-26 Non-Int in treasurehunt-epoch05of13 (05)	2545 Secs (2545 Secs) [==>]	[1]
<p><i>Comments: Following the June 4 2020 recommendations of J. Anderson (2020) "CURRENT CTE-MITIGATION RECOMMENDATIONS", we aim for a minimum background level of 20 e-/pix in each WFC3/UVIS F275W exposure. Taking into account the raised natural background of this pseudo-CVZ visit, the WFC3/UVIS ETC shows that this requirement becomes satisfied for FLASH=11. The APT Phase-II diagnostics seem to still test the older (now superseded) recommendation of a minimum of only 12 e-/pix, and therefore result in a warning that the specified postflash may be too high.</i></p>									
6		(1) JWST-NEP-TDF	ACS/WFC, ACCUM, WFCENTER	F606W		POS TARG +45.100, +365.100	Sequence 1-26 Non-Int in treasurehunt-epoch05of13 (05) Prime + Parallel Group 6-8 in Sequence 1-26 Non-Int in treasurehunt-epoch05of13 (05)	1140 Secs (1140 Secs) [==>]	[1]
<p><i>Comments: The specified POS_TARG values intentionally place the WFC3/UVIS and ACS/WFC instrument apertures off the coordinates of the target (i.e., the center of the JWST NEP Time-Domain Field) to their intended locations within an annulus surrounding the extant HST data.</i></p>									

Proposal 16252 - treasurehunt-epoch05of13 (05) - TREASUREHUNT: Hubble's UV-Visible treasury imaging of the JWST NEP Time...

7	(1) JWST-NEP-TDF ACS/WFC, ACCUM, WFCENTER F435W	POS TARG +45.100 ,+365.100	Sequence 1-26 Non-Int in treasurehunt-epoch05of13 (05) Prime + Parallel Group 6-8 in Sequence 1-26 Non-Int in treasurehunt-epoch05of13 (05)	1140 Secs (1140 Secs) [==>]	[1]
8	(WFC3UVI ANY S.im.1445613) WFC3/UVIS, ACCUM, UVIS F275W FLASH=11		Sequence 1-26 Non-Int in treasurehunt-epoch05of13 (05) Prime + Parallel Group 6-8 in Sequence 1-26 Non-Int in treasurehunt-epoch05of13 (05)	2504 Secs (2504 Secs) [==>]	[1]
<p><i>Comments: Following the June 4 2020 recommendations of J. Anderson (2020) "CURRENT CTE-MITIGATION RECOMMENDATIONS", we aim for a minimum background level of 20 e-/pix in each WFC3/UVIS F275W exposure. Taking into account the raised natural background of this pseudo-CVZ visit, the WFC3/UVIS ETC shows that this requirement becomes satisfied for FLASH=11. The APT Phase-II diagnostics seem to still test the older (now superseded) recommendation of a minimum of only 12 e-/pix, and therefore result in a warning that the specified postflash may be too high.</i></p>					
9	(1) JWST-NEP-TDF ACS/WFC, ACCUM, WFCENTER F435W	POS TARG +44.900 ,+364.900	Sequence 1-26 Non-Int in treasurehunt-epoch05of13 (05) Prime + Parallel Group 9-11 in Sequence 1-26 Non-Int in treasurehunt-epoch05of13 (05)	1245 Secs (1245 Secs) [==>]	[2]
<p><i>Comments: The specified POS_TARG values intentionally place the WFC3/UVIS and ACS/WFC instrument apertures off the coordinates of the target (i.e., the center of the JWST NEP Time-Domain Field) to their intended locations within an annulus surrounding the extant HST data.</i></p>					
10	(1) JWST-NEP-TDF ACS/WFC, ACCUM, WFCENTER F606W	POS TARG +44.900 ,+364.900	Sequence 1-26 Non-Int in treasurehunt-epoch05of13 (05) Prime + Parallel Group 9-11 in Sequence 1-26 Non-Int in treasurehunt-epoch05of13 (05)	1245 Secs (1245 Secs) [==>]	[2]
11	(WFC3UVI ANY S.im.1445613) WFC3/UVIS, ACCUM, UVIS F275W FLASH=11		Sequence 1-26 Non-Int in treasurehunt-epoch05of13 (05) Prime + Parallel Group 9-11 in Sequence 1-26 Non-Int in treasurehunt-epoch05of13 (05)	2714 Secs (2714 Secs) [==>]	[2]
<p><i>Comments: Following the June 4 2020 recommendations of J. Anderson (2020) "CURRENT CTE-MITIGATION RECOMMENDATIONS", we aim for a minimum background level of 20 e-/pix in each WFC3/UVIS F275W exposure. Taking into account the raised natural background of this pseudo-CVZ visit, the WFC3/UVIS ETC shows that this requirement becomes satisfied for FLASH=11. The APT Phase-II diagnostics seem to still test the older (now superseded) recommendation of a minimum of only 12 e-/pix, and therefore result in a warning that the specified postflash may be too high.</i></p>					
12	(1) JWST-NEP-TDF ACS/WFC, ACCUM, WFCENTER F606W	POS TARG +45.100 ,+364.900	Sequence 1-26 Non-Int in treasurehunt-epoch05of13 (05) Prime + Parallel Group 12-14 in Sequence 1-26 Non-Int in treasurehunt-epoch05of13 (05)	1253 Secs (1253 Secs) [==>]	[2]
<p><i>Comments: The specified POS_TARG values intentionally place the WFC3/UVIS and ACS/WFC instrument apertures off the coordinates of the target (i.e., the center of the JWST NEP Time-Domain Field) to their intended locations within an annulus surrounding the extant HST data.</i></p>					

Proposal 16252 - treasurehunt-epoch05of13 (05) - TREASUREHUNT: Hubble's UV-Visible treasury imaging of the JWST NEP Time-...

13	(1) JWST-NEP-TDF ACS/WFC, ACCUM, WFCENTER F435W	POS TARG +45.100 ,+364.900	Sequence 1-26 Non-Int in treasurehunt-epoch05of13 (05) Prime + Parallel Group 12-14 in Sequence 1-26 Non-Int in treasurehunt-epoch05of13 (05)	1254 Secs (1254 Secs) [==>]	[2]
14	(WFC3UVI ANY S.im.1445613) WFC3/UVIS, ACCUM, UVIS F275W FLASH=11		Sequence 1-26 Non-Int in treasurehunt-epoch05of13 (05) Prime + Parallel Group 12-14 in Sequence 1-26 Non-Int in treasurehunt-epoch05of13 (05)	2731 Secs (2731 Secs) [==>]	[2]
<p><i>Comments: Following the June 4 2020 recommendations of J. Anderson (2020) "CURRENT CTE-MITIGATION RECOMMENDATIONS", we aim for a minimum background level of 20 e-/pix in each WFC3/UVIS F275W exposure. Taking into account the raised natural background of this pseudo-CVZ visit, the WFC3/UVIS ETC shows that this requirement becomes satisfied for FLASH=11. The APT Phase-II diagnostics seem to still test the older (now superseded) recommendation of a minimum of only 12 e-/pix, and therefore result in a warning that the specified postflash may be too high.</i></p>					
15	(1) JWST-NEP-TDF ACS/WFC, ACCUM, WFCENTER F435W	POS TARG +44.800 ,+365.200	Sequence 1-26 Non-Int in treasurehunt-epoch05of13 (05) Prime + Parallel Group 15-17 in Sequence 1-26 Non-Int in treasurehunt-epoch05of13 (05)	1245 Secs (1245 Secs) [==>]	[3]
<p><i>Comments: The specified POS_TARG values intentionally place the WFC3/UVIS and ACS/WFC instrument apertures off the coordinates of the target (i.e., the center of the JWST NEP Time-Domain Field) to their intended locations within an annulus surrounding the extant HST data.</i></p>					
16	(1) JWST-NEP-TDF ACS/WFC, ACCUM, WFCENTER F606W	POS TARG +44.800 ,+365.200	Sequence 1-26 Non-Int in treasurehunt-epoch05of13 (05) Prime + Parallel Group 15-17 in Sequence 1-26 Non-Int in treasurehunt-epoch05of13 (05)	1245 Secs (1245 Secs) [==>]	[3]
17	(WFC3UVI ANY S.im.1445613) WFC3/UVIS, ACCUM, UVIS F275W FLASH=11		Sequence 1-26 Non-Int in treasurehunt-epoch05of13 (05) Prime + Parallel Group 15-17 in Sequence 1-26 Non-Int in treasurehunt-epoch05of13 (05)	2714 Secs (2714 Secs) [==>]	[3]
<p><i>Comments: Following the June 4 2020 recommendations of J. Anderson (2020) "CURRENT CTE-MITIGATION RECOMMENDATIONS", we aim for a minimum background level of 20 e-/pix in each WFC3/UVIS F275W exposure. Taking into account the raised natural background of this pseudo-CVZ visit, the WFC3/UVIS ETC shows that this requirement becomes satisfied for FLASH=11. The APT Phase-II diagnostics seem to still test the older (now superseded) recommendation of a minimum of only 12 e-/pix, and therefore result in a warning that the specified postflash may be too high.</i></p>					
18	(1) JWST-NEP-TDF ACS/WFC, ACCUM, WFCENTER F606W	POS TARG +45.000 ,+365.200	Sequence 1-26 Non-Int in treasurehunt-epoch05of13 (05) Prime + Parallel Group 18-20 in Sequence 1-26 Non-Int in treasurehunt-epoch05of13 (05)	1253 Secs (1253 Secs) [==>]	[3]
<p><i>Comments: The specified POS_TARG values intentionally place the WFC3/UVIS and ACS/WFC instrument apertures off the coordinates of the target (i.e., the center of the JWST NEP Time-Domain Field) to their intended locations within an annulus surrounding the extant HST data.</i></p>					

Proposal 16252 - treasurehunt-epoch05of13 (05) - TREASUREHUNT: Hubble's UV-Visible treasury imaging of the JWST NEP Time...

19	(1) JWST-NEP-TDF ACS/WFC, ACCUM, WFCENTER F435W	POS TARG +45.000 ,+365.200	Sequence 1-26 Non-Int in treasurehunt-epoch05of13 (05) Prime + Parallel Group 18-20 in Sequence 1-26 Non-Int in treasurehunt-epoch05of13 (05)	1254 Secs (1254 Secs) [==>]	[3]
20	(WFC3UVI ANY S.im.1445613) WFC3/UVIS, ACCUM, UVIS F275W FLASH=11		Sequence 1-26 Non-Int in treasurehunt-epoch05of13 (05) Prime + Parallel Group 18-20 in Sequence 1-26 Non-Int in treasurehunt-epoch05of13 (05)	2731 Secs (2731 Secs) [==>]	[3]
<p><i>Comments: Following the June 4 2020 recommendations of J. Anderson (2020) "CURRENT CTE-MITIGATION RECOMMENDATIONS", we aim for a minimum background level of 20 e-/pix in each WFC3/UVIS F275W exposure. Taking into account the raised natural background of this pseudo-CVZ visit, the WFC3/UVIS ETC shows that this requirement becomes satisfied for FLASH=11. The APT Phase-II diagnostics seem to still test the older (now superseded) recommendation of a minimum of only 12 e-/pix, and therefore result in a warning that the specified postflash may be too high.</i></p>					
21	(1) JWST-NEP-TDF ACS/WFC, ACCUM, WFCENTER F435W	POS TARG +44.800 ,+365.000	Sequence 1-26 Non-Int in treasurehunt-epoch05of13 (05) Prime + Parallel Group 21-23 in Sequence 1-26 Non-Int in treasurehunt-epoch05of13 (05)	994 Secs (994 Secs) [==>]	[4]
<p><i>Comments: The specified POS_TARG values intentionally place the WFC3/UVIS and ACS/WFC instrument apertures off the coordinates of the target (i.e., the center of the JWST NEP Time-Domain Field) to their intended locations within an annulus surrounding the extant HST data.</i></p>					
22	(1) JWST-NEP-TDF ACS/WFC, ACCUM, WFCENTER F606W	POS TARG +44.800 ,+365.000	Sequence 1-26 Non-Int in treasurehunt-epoch05of13 (05) Prime + Parallel Group 21-23 in Sequence 1-26 Non-Int in treasurehunt-epoch05of13 (05)	994 Secs (994 Secs) [==>]	[4]
23	(WFC3UVI ANY S.im.1445644) WFC3/UVIS, ACCUM, UVIS F275W FLASH=12		Sequence 1-26 Non-Int in treasurehunt-epoch05of13 (05) Prime + Parallel Group 21-23 in Sequence 1-26 Non-Int in treasurehunt-epoch05of13 (05)	2212 Secs (2212 Secs) [==>]	[4]
<p><i>Comments: Following the June 4 2020 recommendations of J. Anderson (2020) "CURRENT CTE-MITIGATION RECOMMENDATIONS", we aim for a minimum background level of 20 e-/pix in each WFC3/UVIS F275W exposure. Taking into account the raised natural background of this pseudo-CVZ visit, the WFC3/UVIS ETC shows that this requirement becomes satisfied for FLASH=12. The APT Phase-II diagnostics seem to still test the older (now superseded) recommendation of a minimum of only 12 e-/pix, and therefore result in a warning that the specified postflash may be too high.</i></p>					
24	(1) JWST-NEP-TDF ACS/WFC, ACCUM, WFCENTER F606W	POS TARG +45.000 ,+365.000	Sequence 1-26 Non-Int in treasurehunt-epoch05of13 (05) Prime + Parallel Group 24-26 in Sequence 1-26 Non-Int in treasurehunt-epoch05of13 (05)	997 Secs (997 Secs) [==>]	[4]
<p><i>Comments: The specified POS_TARG values intentionally place the WFC3/UVIS and ACS/WFC instrument apertures off the coordinates of the target (i.e., the center of the JWST NEP Time-Domain Field) to their intended locations within an annulus surrounding the extant HST data.</i></p>					

Proposal 16252 - treasurehunt-epoch05of13 (05) - TREASUREHUNT: Hubble's UV-Visible treasury imaging of the JWST NEP Time-...

25	(1) JWST-NEP-TDF ACS/WFC, ACCUM, WFCENTER F435W	POS TARG +45.000 ,+365.000	Sequence 1-26 Non-Int in treasurehunt-epoch05of13 (05)  Prime + Parallel Group 24-26 in Sequence 1-26 Non-Int in treasurehunt-epoch05of13 (05)	997 Secs (997 Secs)  [==>]	[4]
26	(WFC3UVI ANY S.im.144564 4) WFC3/UVIS, ACCUM, UVIS F275W FLASH=12		Sequence 1-26 Non-Int in treasurehunt-epoch05of13 (05)  Prime + Parallel Group 24-26 in Sequence 1-26 Non-Int in treasurehunt-epoch05of13 (05)	2198 Secs (2198 Secs)  [==>]	[4]
<p><i>Comments: Following the June 4 2020 recommendations of J. Anderson (2020) "CURRENT CTE-MITIGATION RECOMMENDATIONS", we aim for a minimum background level of 20 e-/pix in each WFC3/UVIS F275W exposure. Taking into account the raised natural background of this pseudo-CVZ visit, the WFC3/UVIS ETC shows that this requirement becomes satisfied for FLASH=12. The APT Phase-II diagnostics seem to still test the older (now superseded) recommendation of a minimum of only 12 e-/pix, and therefore result in a warning that the specified postflash may be too high.</i></p>					

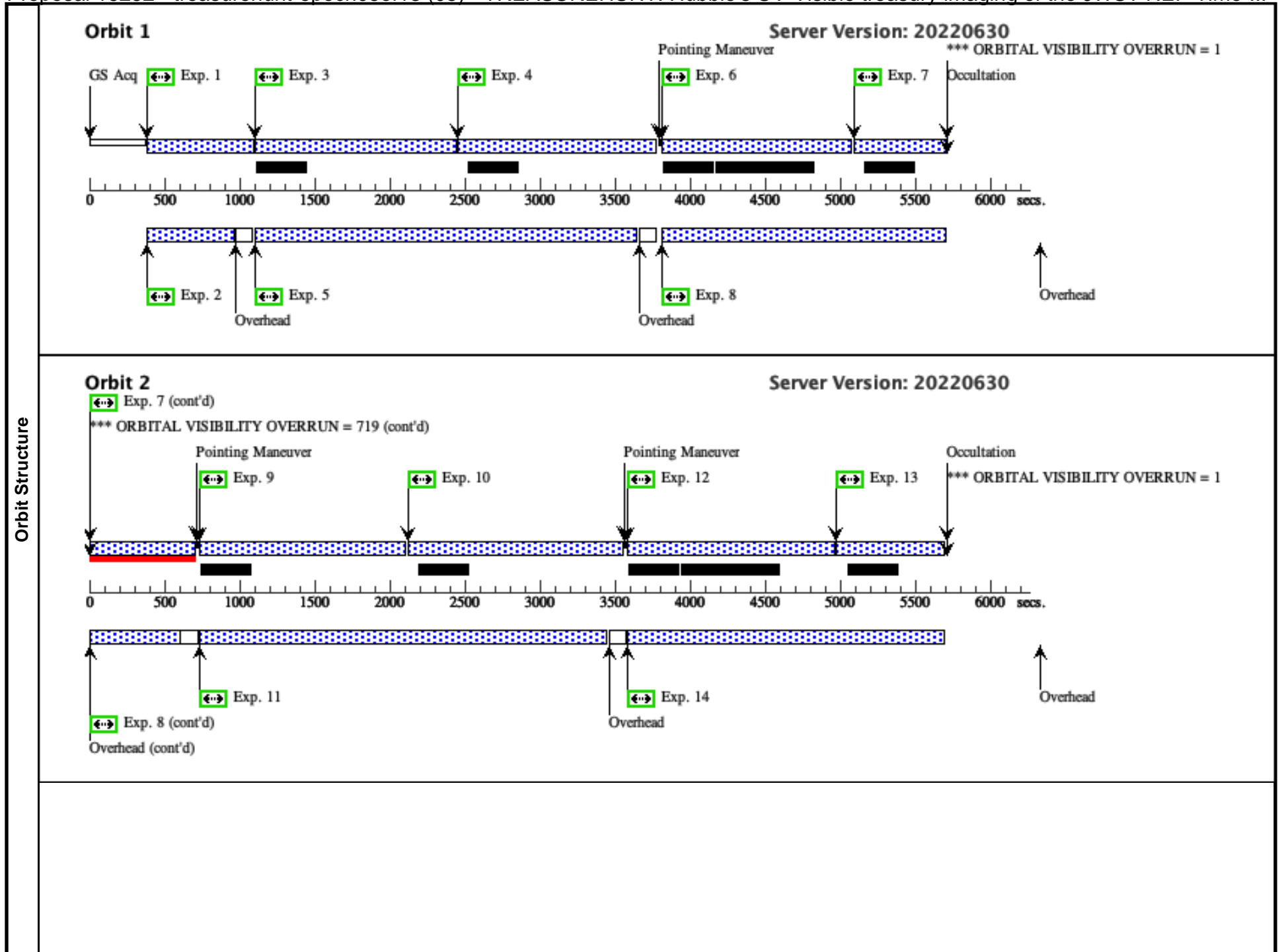

### Orbit 3

Server Version: 20220630

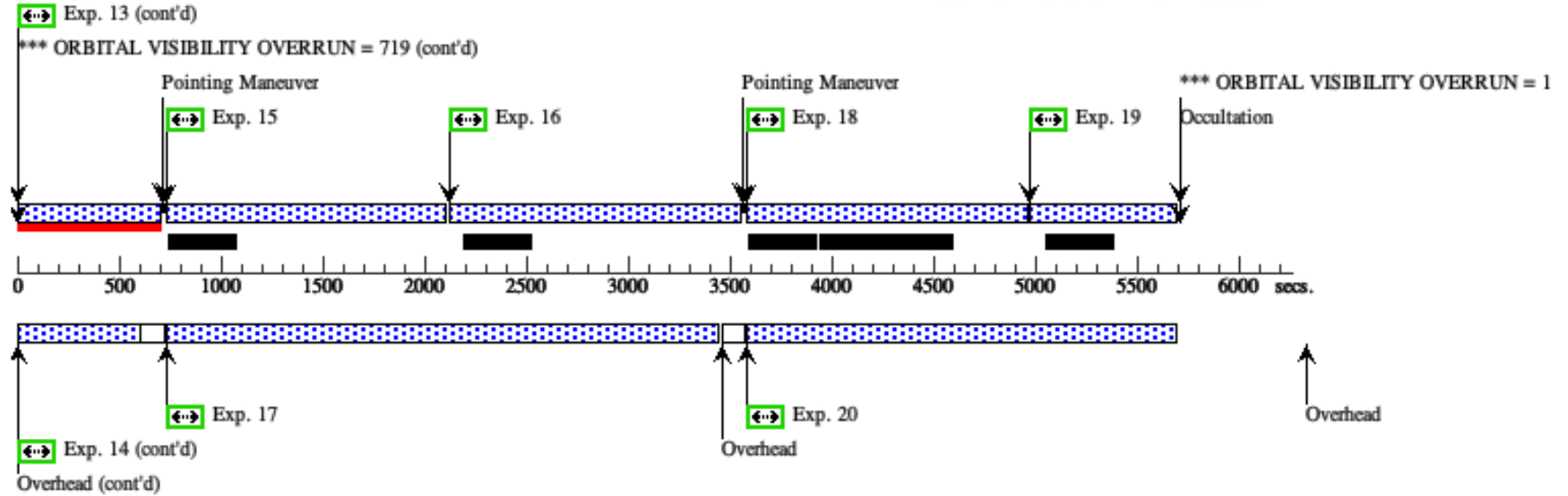

### Orbit 4

Server Version: 20220630

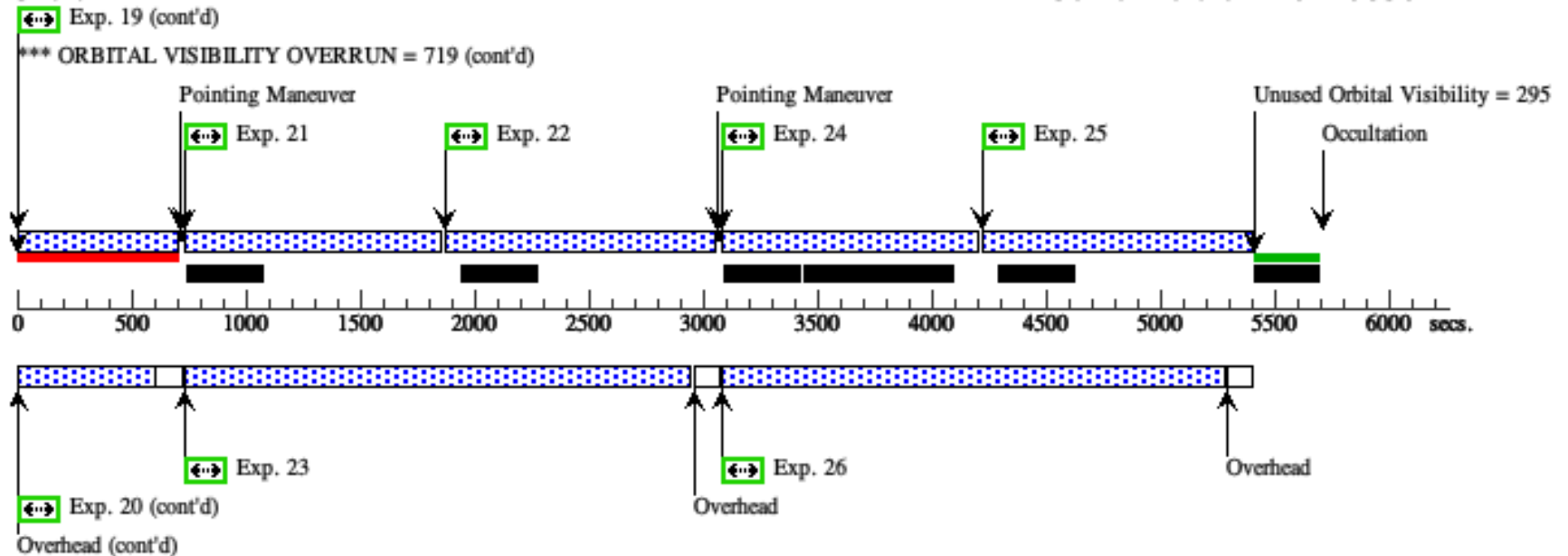

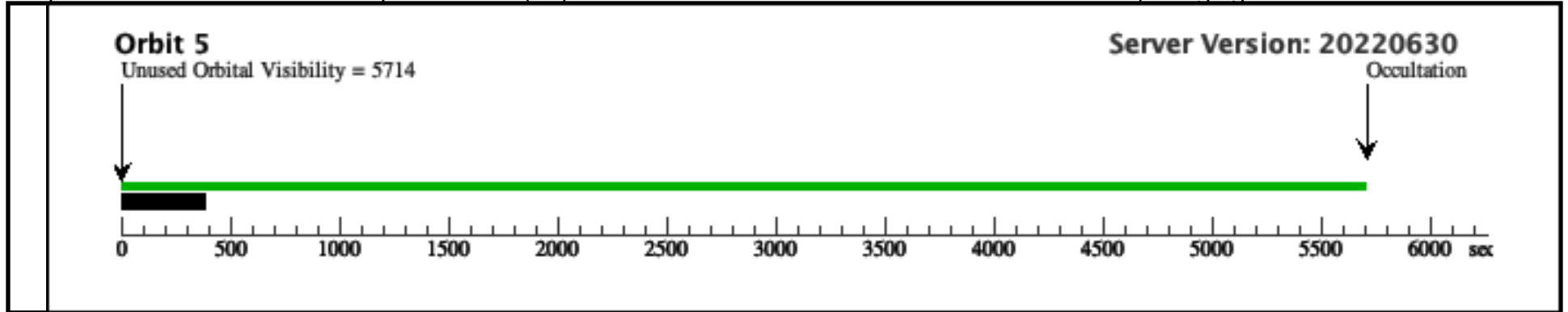

Proposal 16252 - treasurehunt-epoch6Aof13 (6A) - TREASUREHUNT: Hubble's UV-Visible treasury imaging of the JWST NEP Time...

Tue Oct 25 19:01:02 GMT 2022

<b>Visit</b>	<p><b>Proposal 16252, treasurehunt-epoch6Aof13 (6A), implementation</b></p> <p><b>Diagnostic Status: Error</b></p> <p>Scientific Instruments: WFC3/UVIS, ACS/WFC</p> <p>Special Requirements: BRIGHT EARTH AVOID 13.5D; ORIENT 47D TO 47 D; BETWEEN 2022.301:03:59:04 AND 2022.301:04:05:04; BETWEEN 2022.302:03:47:29 AND 2022.302:03:53:29; BETWEEN 2022.303:02:00:42 AND 2022.303:02:06:42; BETWEEN 2022.304:01:27:11 AND 2022.304:01:33:11; BETWEEN 2022.305:01:15:41 AND 2022.305:01:21:41; BETWEEN 2022.305:23:28:59 AND 2022.305:23:34:59; VISIBILITY INTERVAL 5714 S</p> <p><i>Comments: Epoch 6B is a 4-orbit (pseudo)CVZ visit the TTRB has approved as a repeat of lost visit 06, using the opportunity at ORIENT = 47 degrees and ACS/WFC as primary. After guide star acquisition at the start of the first orbit, the guide star remains visible and locked for the duration of the visit, so no guide star re-acquisition in subsequent orbits will be required in orbits 2--4. This strategy is the same as adopted for GO-15278 in Cycle 25, and as successfully executed through Cycle 28. Specified POS_TARGs with respect to the nominal field center place the instrument apertures at the intended location within the 13-epoch pattern. While APT throws an error for the specified Bright Earth Avoidance angle of 13.5 degrees, this value is intended, and proven to schedule and execute for a pseudo-CVZ visit.</i></p>																						
	<p>(treasurehunt-epoch6Aof13 (6A)) Error (Form): The specified Bright Earth Avoidance angle is outside the permitted range.</p> <p>(treasurehunt-epoch6Aof13 (6A)) Warning (Orbit Planner): NO VISIBILITY TABLE CORRESPONDING TO BRIGHT EARTH AVOIDANCE ANGLE</p> <p>(treasurehunt-epoch6Aof13 (6A)) Warning (Orbit Planner): ORBITAL VISIBILITY OVERRUN</p> <p>(treasurehunt-epoch6Aof13 (6A)) Warning (Orbit Planner): ORBITAL VISIBILITY OVERRUN</p> <p>(treasurehunt-epoch6Aof13 (6A)) Warning (Orbit Planner): ORBITAL VISIBILITY OVERRUN</p> <p>(treasurehunt-epoch6Aof13 (6A)) Warning (Orbit Planner): ORBITAL VISIBILITY OVERRUN</p> <p>(Parallel Exposure 5 (Prime + Parallel Group 3-5 in Sequence 1-26 Non-Int in treasurehunt-epoch6Aof13 (6A))) Warning (Form): FLASH level may be too low for this exposure or a short subexposure. See extended explanation in the diagnostic browser</p> <p>(Parallel Exposure 8 (Prime + Parallel Group 6-8 in Sequence 1-26 Non-Int in treasurehunt-epoch6Aof13 (6A))) Warning (Form): FLASH level may be too low for this exposure or a short subexposure. See extended explanation in the diagnostic browser</p> <p>(Parallel Exposure 11 (Prime + Parallel Group 9-11 in Sequence 1-26 Non-Int in treasurehunt-epoch6Aof13 (6A))) Warning (Form): FLASH level may be too low for this exposure or a short subexposure. See extended explanation in the diagnostic browser</p> <p>(Parallel Exposure 14 (Prime + Parallel Group 12-14 in Sequence 1-26 Non-Int in treasurehunt-epoch6Aof13 (6A))) Warning (Form): FLASH level may be too low for this exposure or a short subexposure. See extended explanation in the diagnostic browser</p> <p>(Parallel Exposure 17 (Prime + Parallel Group 15-17 in Sequence 1-26 Non-Int in treasurehunt-epoch6Aof13 (6A))) Warning (Form): FLASH level may be too low for this exposure or a short subexposure. See extended explanation in the diagnostic browser</p> <p>(Parallel Exposure 20 (Prime + Parallel Group 18-20 in Sequence 1-26 Non-Int in treasurehunt-epoch6Aof13 (6A))) Warning (Form): FLASH level may be too low for this exposure or a short subexposure. See extended explanation in the diagnostic browser</p>																						
<b>Fixed Targets</b>	<table border="1"> <thead> <tr> <th>#</th> <th>Name</th> <th>Target Coordinates</th> <th>Targ. Coord. Corrections</th> <th>Fluxes</th> <th>Miscellaneous</th> </tr> </thead> <tbody> <tr> <td>(5)</td> <td>JWST-NEP-TDF-6AWFC</td> <td>RA: 17 22 27.3300 (260.6138750d) Dec: +65 55 15.40 (65.92094d)</td> <td></td> <td>V=27.0+/-1.0</td> <td>Reference Frame: ICRS</td> </tr> <tr> <td></td> <td>Alt Name1: WTDF</td> <td>Equinox: J2000</td> <td></td> <td></td> <td></td> </tr> </tbody> </table> <p><i>Comments: The target field is centered on the extant HST observations of the JWST NEP Time-Domain Field of GO-15278. Allocated JWST GTO observations will provide both NIRCcam imaging and NIRISS slitless spectroscopy in this field, which was defined to be the cleanest ~14' diameter area in JWST's northern continuous viewing zone, where JWST will conduct a deep extragalactic time-domain survey, with added utility for extreme outer solar system and near-Galactic time-domain science. The JWST NEP Time-Domain Field is developed as a *community field*, and has deep coverage accross the electromagnetic spectrum from X-ray through long-wave radio. The present HST program will complete near-contiguous 3-filter coverage in the UV--Visible, targeting the annulus surrounding the extant HST observations of GO-15278.</i></p> <p>Category=UNIDENTIFIED Description=[HIGH LATITUDE FIELD, INFRARED EMITTER, OPTICAL EMITTER, ULTRAVIOLET EMITTER]</p>					#	Name	Target Coordinates	Targ. Coord. Corrections	Fluxes	Miscellaneous	(5)	JWST-NEP-TDF-6AWFC	RA: 17 22 27.3300 (260.6138750d) Dec: +65 55 15.40 (65.92094d)		V=27.0+/-1.0	Reference Frame: ICRS		Alt Name1: WTDF	Equinox: J2000			
	#	Name	Target Coordinates	Targ. Coord. Corrections	Fluxes	Miscellaneous																	
(5)	JWST-NEP-TDF-6AWFC	RA: 17 22 27.3300 (260.6138750d) Dec: +65 55 15.40 (65.92094d)		V=27.0+/-1.0	Reference Frame: ICRS																		
	Alt Name1: WTDF	Equinox: J2000																					

Proposal 16252 - treasurehunt-epoch6Aof13 (6A) - TREASUREHUNT: Hubble's UV-Visible treasury imaging of the JWST NEP Time...

#	Label (ETC Run)	Target	Config,Mode,Aperture	Spectral Els.	Opt. Params.	Special Reqs.	Groups	Exp. Time (Total)/[Actual Dur.]	Orbit
1		(5) JWST-NEP-TDF -6AWFC	ACS/WFC, ACCUM, WFCENTER	F435W		POS TARG -0.100,+ 0.100	Sequence 1-26 Non-Int in treasurehunt-epoch6Aof13 (6A)  Prime + Parallel Group 1-2 in Sequence 1-26 Non-Int in treasurehunt-epoch6Aof13 (6A)	1100 Secs (1100 Secs) [==>]	[1]
<p><i>Comments: The specified POS_TARG values intentionally place the WFC3/UVIS and ACS/WFC instrument apertures off the coordinates of the target (i.e., the center of the JWST NEP Time-Domain Field) to their intended locations within an annulus surrounding the extant HST data.</i></p>									
2	(WFC3UVIS im.1445613)	ANY	WFC3/UVIS, ACCUM, UVIS	F275W	FLASH=15		Sequence 1-26 Non-Int in treasurehunt-epoch6Aof13 (6A)  Prime + Parallel Group 1-2 in Sequence 1-26 Non-Int in treasurehunt-epoch6Aof13 (6A)	1150 Secs (1150 Secs) [==>]	[1]
<p><i>Comments: Following the June 4 2020 recommendations of J. Anderson (2020) "CURRENT CTE-MITIGATION RECOMMENDATIONS", we aim for a minimum background level of 20 e-/pix in each WFC3/UVIS F275W exposure. Taking into account the raised natural background of this pseudo-CVZ visit, the WFC3/UVIS ETC shows that this requirement becomes satisfied for FLASH=11. The APT Phase-II diagnostics seem to still test the older (now superseded) recommendation of a minimum of only 12 e-/pix, and therefore result in a warning that the specified postflash may be too high.</i></p>									
3		(5) JWST-NEP-TDF -6AWFC	ACS/WFC, ACCUM, WFCENTER	F435W		POS TARG -0.100,+ 0.100	Sequence 1-26 Non-Int in treasurehunt-epoch6Aof13 (6A)  Prime + Parallel Group 3-5 in Sequence 1-26 Non-Int in treasurehunt-epoch6Aof13 (6A)	1136 Secs (1136 Secs) [==>]	[1]
<p><i>Comments: The specified POS_TARG values intentionally place the WFC3/UVIS and ACS/WFC instrument apertures off the coordinates of the target (i.e., the center of the JWST NEP Time-Domain Field) to their intended locations within an annulus surrounding the extant HST data.</i></p>									
4		(5) JWST-NEP-TDF -6AWFC	ACS/WFC, ACCUM, WFCENTER	F606W		POS TARG -0.100,+ 0.100	Sequence 1-26 Non-Int in treasurehunt-epoch6Aof13 (6A)  Prime + Parallel Group 3-5 in Sequence 1-26 Non-Int in treasurehunt-epoch6Aof13 (6A)	1136 Secs (1136 Secs) [==>]	[1]
5	(WFC3UVIS im.1445613)	ANY	WFC3/UVIS, ACCUM, UVIS	F275W	FLASH=10		Sequence 1-26 Non-Int in treasurehunt-epoch6Aof13 (6A)  Prime + Parallel Group 3-5 in Sequence 1-26 Non-Int in treasurehunt-epoch6Aof13 (6A)	2480 Secs (2480 Secs) [==>]	[1]
<p><i>Comments: Following the June 4 2020 recommendations of J. Anderson (2020) "CURRENT CTE-MITIGATION RECOMMENDATIONS", we aim for a minimum background level of 20 e-/pix in each WFC3/UVIS F275W exposure. Taking into account the raised natural background of this pseudo-CVZ visit, the WFC3/UVIS ETC shows that this requirement becomes satisfied for FLASH=11. The APT Phase-II diagnostics seem to still test the older (now superseded) recommendation of a minimum of only 12 e-/pix, and therefore result in a warning that the specified postflash may be too high.</i></p>									

Proposal 16252 - treasurehunt-epoch6Aof13 (6A) - TREASUREHUNT: Hubble's UV-Visible treasury imaging of the JWST NEP Time...

6	(5) JWST-NEP-TDF -6AWFC	ACS/WFC, ACCUM, WFCENTER	F606W			POS TARG +0.100, +0.100	Sequence 1-26 Non-Int in treasurehunt-epoch6Aof13 (6A)  Prime + Parallel Group 6-8 in Sequence 1-26 Non-Int in treasurehunt-epoch6Aof13 (6A)	1140 Secs (1140 Secs)  [==>]	[1]
<p>Comments: The specified POS_TARG values intentionally place the WFC3/UVIS and ACS/WFC instrument apertures off the coordinates of the target (i.e., the center of the JWST NEP Time-Domain Field) to their intended locations within an annulus surrounding the extant HST data.</p>									
7	(5) JWST-NEP-TDF -6AWFC	ACS/WFC, ACCUM, WFCENTER	F435W			POS TARG +0.100, +0.100	Sequence 1-26 Non-Int in treasurehunt-epoch6Aof13 (6A)  Prime + Parallel Group 6-8 in Sequence 1-26 Non-Int in treasurehunt-epoch6Aof13 (6A)	1140 Secs (1140 Secs)  [==>]	[1]
8	(WFC3UVI ANY S.im.144561 3)	WFC3/UVIS, ACCUM, UVIS	F275W	FLASH=10			Sequence 1-26 Non-Int in treasurehunt-epoch6Aof13 (6A)  Prime + Parallel Group 6-8 in Sequence 1-26 Non-Int in treasurehunt-epoch6Aof13 (6A)	2504 Secs (2504 Secs)  [==>]	[1]
<p>Comments: Following the June 4 2020 recommendations of J. Anderson (2020) "CURRENT CTE-MITIGATION RECOMMENDATIONS", we aim for a minimum background level of 20 e-/pix in each WFC3/UVIS F275W exposure. Taking into account the raised natural background of this pseudo-CVZ visit, the WFC3/UVIS ETC shows that this requirement becomes satisfied for FLASH=11. The APT Phase-II diagnostics seem to still test the older (now superseded) recommendation of a minimum of only 12 e-/pix, and therefore result in a warning that the specified postflash may be too high.</p>									
9	(5) JWST-NEP-TDF -6AWFC	ACS/WFC, ACCUM, WFCENTER	F435W			POS TARG -0.100, -0.100	Sequence 1-26 Non-Int in treasurehunt-epoch6Aof13 (6A)  Prime + Parallel Group 9-11 in Sequence 1-26 Non-Int in treasurehunt-epoch6Aof13 (6A)	1245 Secs (1245 Secs)  [==>]	[2]
<p>Comments: The specified POS_TARG values intentionally place the WFC3/UVIS and ACS/WFC instrument apertures off the coordinates of the target (i.e., the center of the JWST NEP Time-Domain Field) to their intended locations within an annulus surrounding the extant HST data.</p>									
10	(5) JWST-NEP-TDF -6AWFC	ACS/WFC, ACCUM, WFCENTER	F606W			POS TARG -0.100, -0.100	Sequence 1-26 Non-Int in treasurehunt-epoch6Aof13 (6A)  Prime + Parallel Group 9-11 in Sequence 1-26 Non-Int in treasurehunt-epoch6Aof13 (6A)	1245 Secs (1245 Secs)  [==>]	[2]
11	(WFC3UVI ANY S.im.144561 3)	WFC3/UVIS, ACCUM, UVIS	F275W	FLASH=9			Sequence 1-26 Non-Int in treasurehunt-epoch6Aof13 (6A)  Prime + Parallel Group 9-11 in Sequence 1-26 Non-Int in treasurehunt-epoch6Aof13 (6A)	2714 Secs (2714 Secs)  [==>]	[2]
<p>Comments: Following the June 4 2020 recommendations of J. Anderson (2020) "CURRENT CTE-MITIGATION RECOMMENDATIONS", we aim for a minimum background level of 20 e-/pix in each WFC3/UVIS F275W exposure. Taking into account the raised natural background of this pseudo-CVZ visit, the WFC3/UVIS ETC shows that this requirement becomes satisfied for FLASH=11. The APT Phase-II diagnostics seem to still test the older (now superseded) recommendation of a minimum of only 12 e-/pix, and therefore result in a warning that the specified postflash may be too high.</p>									

Proposal 16252 - treasurehunt-epoch6Aof13 (6A) - TREASUREHUNT: Hubble's UV-Visible treasury imaging of the JWST NEP Time...

12	(5) JWST-NEP-TDF -6AWFC	ACS/WFC, ACCUM, WFCENTER	F606W			POS TARG +0.100,- 0.100	Sequence 1-26 Non-Int in treasurehunt-epoch6Aof13 (6A)  Prime + Parallel Group 12-14 in Sequence 1-26 Non-Int in treasurehunt-epoch6Aof13 (6A)	1253 Secs (1253 Secs)  [==>]	[2]
<p>Comments: The specified POS_TARG values intentionally place the WFC3/UVIS and ACS/WFC instrument apertures off the coordinates of the target (i.e., the center of the JWST NEP Time-Domain Field) to their intended locations within an annulus surrounding the extant HST data.</p>									
13	(5) JWST-NEP-TDF -6AWFC	ACS/WFC, ACCUM, WFCENTER	F435W			POS TARG +0.100,- 0.100	Sequence 1-26 Non-Int in treasurehunt-epoch6Aof13 (6A)  Prime + Parallel Group 12-14 in Sequence 1-26 Non-Int in treasurehunt-epoch6Aof13 (6A)	1254 Secs (1254 Secs)  [==>]	[2]
14	(WFC3UVI ANY S.im.144561 3)	WFC3/UVIS, ACCUM, UVIS	F275W	FLASH=9			Sequence 1-26 Non-Int in treasurehunt-epoch6Aof13 (6A)  Prime + Parallel Group 12-14 in Sequence 1-26 Non-Int in treasurehunt-epoch6Aof13 (6A)	2731 Secs (2731 Secs)  [==>]	[2]
<p>Comments: Following the June 4 2020 recommendations of J. Anderson (2020) "CURRENT CTE-MITIGATION RECOMMENDATIONS", we aim for a minimum background level of 20 e-/pix in each WFC3/UVIS F275W exposure. Taking into account the raised natural background of this pseudo-CVZ visit, the WFC3/UVIS ETC shows that this requirement becomes satisfied for FLASH=11. The APT Phase-II diagnostics seem to still test the older (now superseded) recommendation of a minimum of only 12 e-/pix, and therefore result in a warning that the specified postflash may be too high.</p>									
15	(5) JWST-NEP-TDF -6AWFC	ACS/WFC, ACCUM, WFCENTER	F435W			POS TARG -0.200,+ 0.200	Sequence 1-26 Non-Int in treasurehunt-epoch6Aof13 (6A)  Prime + Parallel Group 15-17 in Sequence 1-26 Non-Int in treasurehunt-epoch6Aof13 (6A)	1245 Secs (1245 Secs)  [==>]	[3]
<p>Comments: The specified POS_TARG values intentionally place the WFC3/UVIS and ACS/WFC instrument apertures off the coordinates of the target (i.e., the center of the JWST NEP Time-Domain Field) to their intended locations within an annulus surrounding the extant HST data.</p>									
16	(5) JWST-NEP-TDF -6AWFC	ACS/WFC, ACCUM, WFCENTER	F606W			POS TARG -0.200,+ 0.200	Sequence 1-26 Non-Int in treasurehunt-epoch6Aof13 (6A)  Prime + Parallel Group 15-17 in Sequence 1-26 Non-Int in treasurehunt-epoch6Aof13 (6A)	1245 Secs (1245 Secs)  [==>]	[3]
17	(WFC3UVI ANY S.im.144561 3)	WFC3/UVIS, ACCUM, UVIS	F275W	FLASH=9			Sequence 1-26 Non-Int in treasurehunt-epoch6Aof13 (6A)  Prime + Parallel Group 15-17 in Sequence 1-26 Non-Int in treasurehunt-epoch6Aof13 (6A)	2714 Secs (2714 Secs)  [==>]	[3]
<p>Comments: Following the June 4 2020 recommendations of J. Anderson (2020) "CURRENT CTE-MITIGATION RECOMMENDATIONS", we aim for a minimum background level of 20 e-/pix in each WFC3/UVIS F275W exposure. Taking into account the raised natural background of this pseudo-CVZ visit, the WFC3/UVIS ETC shows that this requirement becomes satisfied for FLASH=11. The APT Phase-II diagnostics seem to still test the older (now superseded) recommendation of a minimum of only 12 e-/pix, and therefore result in a warning that the specified postflash may be too high.</p>									

Proposal 16252 - treasurehunt-epoch6Aof13 (6A) - TREASUREHUNT: Hubble's UV-Visible treasury imaging of the JWST NEP Time...

18	(5) JWST-NEP-TDF -6AWFC	ACS/WFC, ACCUM, WFCENTER	F606W			POS TARG +0.000, +0.200	Sequence 1-26 Non-Int in treasurehunt-epoch6Aof13 (6A)  Prime + Parallel Group 18-20 in Sequence 1-26 Non-Int in treasurehunt-epoch6Aof13 (6A)	1253 Secs (1253 Secs)  [==>]	[3]
<p>Comments: The specified POS_TARG values intentionally place the WFC3/UVIS and ACS/WFC instrument apertures off the coordinates of the target (i.e., the center of the JWST NEP Time-Domain Field) to their intended locations within an annulus surrounding the extant HST data.</p>									
19	(5) JWST-NEP-TDF -6AWFC	ACS/WFC, ACCUM, WFCENTER	F435W			POS TARG +0.000, +0.200	Sequence 1-26 Non-Int in treasurehunt-epoch6Aof13 (6A)  Prime + Parallel Group 18-20 in Sequence 1-26 Non-Int in treasurehunt-epoch6Aof13 (6A)	1254 Secs (1254 Secs)  [==>]	[3]
20	(WFC3UVI ANY S.im.144561 3)	WFC3/UVIS, ACCUM, UVIS	F275W	FLASH=9			Sequence 1-26 Non-Int in treasurehunt-epoch6Aof13 (6A)  Prime + Parallel Group 18-20 in Sequence 1-26 Non-Int in treasurehunt-epoch6Aof13 (6A)	2731 Secs (2731 Secs)  [==>]	[3]
<p>Comments: Following the June 4 2020 recommendations of J. Anderson (2020) "CURRENT CTE-MITIGATION RECOMMENDATIONS", we aim for a minimum background level of 20 e-/pix in each WFC3/UVIS F275W exposure. Taking into account the raised natural background of this pseudo-CVZ visit, the WFC3/UVIS ETC shows that this requirement becomes satisfied for FLASH=11. The APT Phase-II diagnostics seem to still test the older (now superseded) recommendation of a minimum of only 12 e-/pix, and therefore result in a warning that the specified postflash may be too high.</p>									
21	(5) JWST-NEP-TDF -6AWFC	ACS/WFC, ACCUM, WFCENTER	F435W			POS TARG -0.200,+ 0.000	Sequence 1-26 Non-Int in treasurehunt-epoch6Aof13 (6A)  Prime + Parallel Group 21-23 in Sequence 1-26 Non-Int in treasurehunt-epoch6Aof13 (6A)	994 Secs (994 Secs)  [==>]	[4]
<p>Comments: The specified POS_TARG values intentionally place the WFC3/UVIS and ACS/WFC instrument apertures off the coordinates of the target (i.e., the center of the JWST NEP Time-Domain Field) to their intended locations within an annulus surrounding the extant HST data.</p>									
22	(5) JWST-NEP-TDF -6AWFC	ACS/WFC, ACCUM, WFCENTER	F606W			POS TARG -0.200,+ 0.000	Sequence 1-26 Non-Int in treasurehunt-epoch6Aof13 (6A)  Prime + Parallel Group 21-23 in Sequence 1-26 Non-Int in treasurehunt-epoch6Aof13 (6A)	994 Secs (994 Secs)  [==>]	[4]
23	(WFC3UVI ANY S.im.144564 4)	WFC3/UVIS, ACCUM, UVIS	F275W	FLASH=11			Sequence 1-26 Non-Int in treasurehunt-epoch6Aof13 (6A)  Prime + Parallel Group 21-23 in Sequence 1-26 Non-Int in treasurehunt-epoch6Aof13 (6A)	2212 Secs (2212 Secs)  [==>]	[4]
<p>Comments: Following the June 4 2020 recommendations of J. Anderson (2020) "CURRENT CTE-MITIGATION RECOMMENDATIONS", we aim for a minimum background level of 20 e-/pix in each WFC3/UVIS F275W exposure. Taking into account the raised natural background of this pseudo-CVZ visit, the WFC3/UVIS ETC shows that this requirement becomes satisfied for FLASH=12. The APT Phase-II diagnostics seem to still test the older (now superseded) recommendation of a minimum of only 12 e-/pix, and therefore result in a warning that the specified postflash may be too high.</p>									

Proposal 16252 - treasurehunt-epoch6Aof13 (6A) - TREASUREHUNT: Hubble's UV-Visible treasury imaging of the JWST NEP Time...

24	(5) JWST-NEP-TDF -6AWFC	ACS/WFC, ACCUM, WFCENTER	F606W		POS TARG +0.000, +0.000	Sequence 1-26 Non-Int in treasurehunt-epoch6Aof13 (6A)  Prime + Parallel Group 24-26 in Sequence 1-26 Non-Int in treasurehunt-epoch6Aof13 (6A)	997 Secs (997 Secs) [==>]	[4]
<p><i>Comments: The specified POS_TARG values intentionally place the WFC3/UVIS and ACS/WFC instrument apertures off the coordinates of the target (i.e., the center of the JWST NEP Time-Domain Field) to their intended locations within an annulus surrounding the extant HST data.</i></p>								
25	(5) JWST-NEP-TDF -6AWFC	ACS/WFC, ACCUM, WFCENTER	F435W		POS TARG +0.000, +0.000	Sequence 1-26 Non-Int in treasurehunt-epoch6Aof13 (6A)  Prime + Parallel Group 24-26 in Sequence 1-26 Non-Int in treasurehunt-epoch6Aof13 (6A)	997 Secs (997 Secs) [==>]	[4]
26	(WFC3UVI ANY S.im.144564 4)	WFC3/UVIS, ACCUM, UVIS	F275W	FLASH=11		Sequence 1-26 Non-Int in treasurehunt-epoch6Aof13 (6A)  Prime + Parallel Group 24-26 in Sequence 1-26 Non-Int in treasurehunt-epoch6Aof13 (6A)	2198 Secs (2198 Secs) [==>]	[4]
<p><i>Comments: Following the June 4 2020 recommendations of J. Anderson (2020) "CURRENT CTE-MITIGATION RECOMMENDATIONS", we aim for a minimum background level of 20 e-/pix in each WFC3/UVIS F275W exposure. Taking into account the raised natural background of this pseudo-CVZ visit, the WFC3/UVIS ETC shows that this requirement becomes satisfied for FLASH=12. The APT Phase-II diagnostics seem to still test the older (now superseded) recommendation of a minimum of only 12 e-/pix, and therefore result in a warning that the specified postflash may be too high.</i></p>								

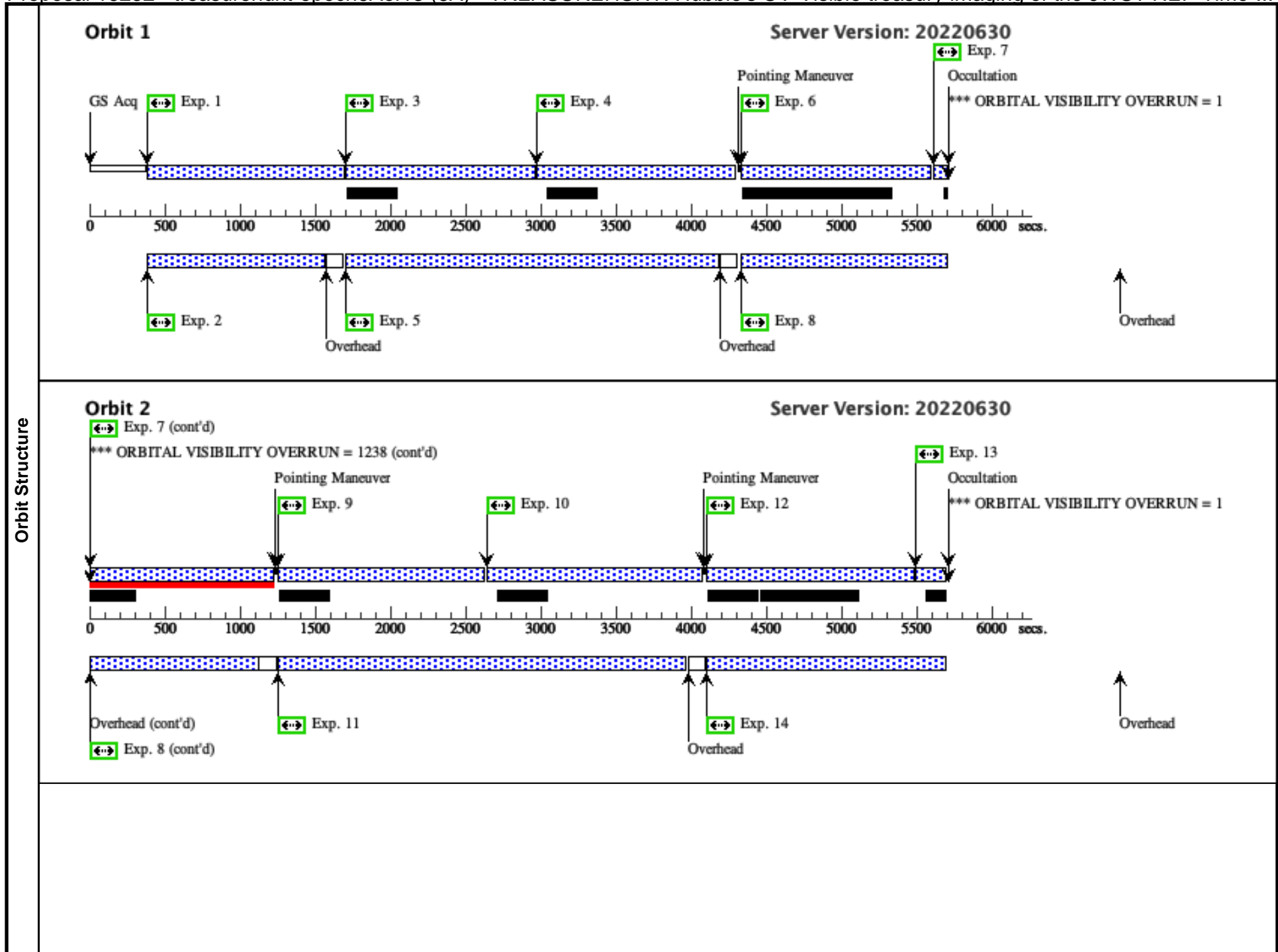

**Orbit 3**

Server Version: 20220630

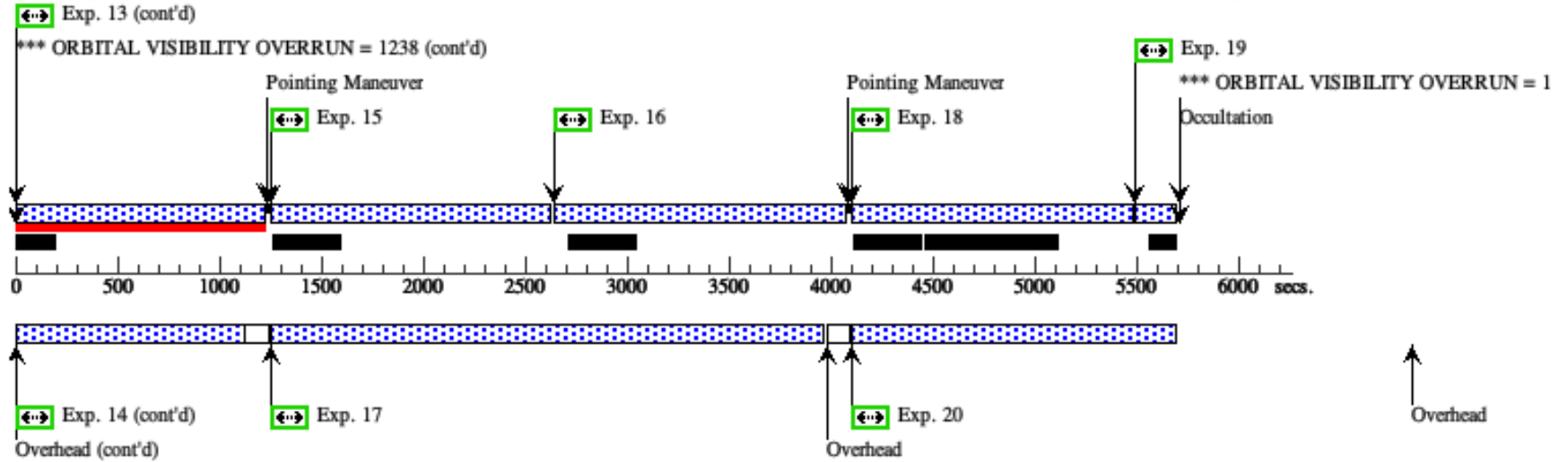

**Orbit 4**

Server Version: 20220630

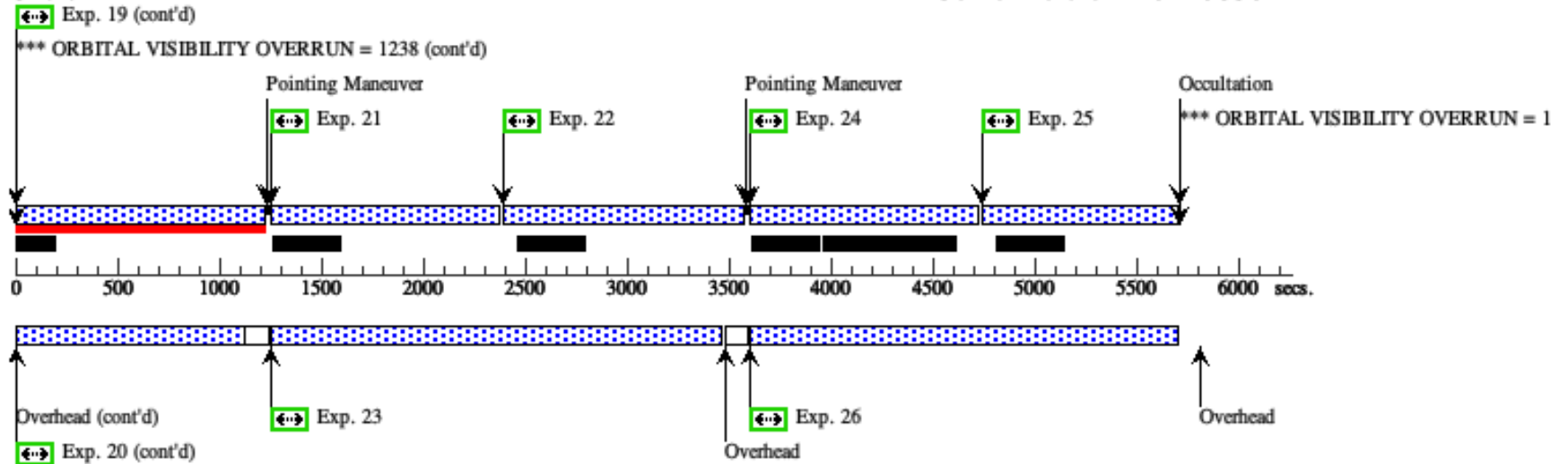

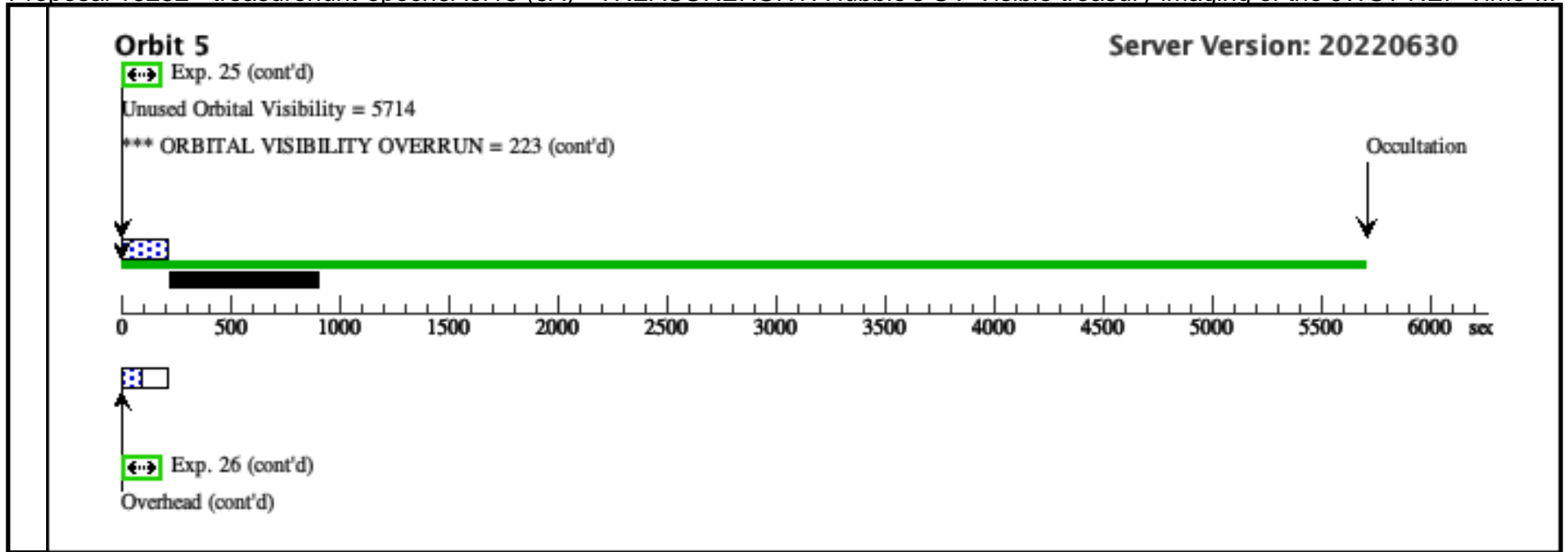

Proposal 16252 - treasurehunt-epoch6Bof13 (6B) - TREASUREHUNT: Hubble's UV-Visible treasury imaging of the JWST NEP Time...

<b>Visit</b>	<p><b>Proposal 16252, treasurehunt-epoch6Bof13 (6B), completed</b> <span style="float: right;">Tue Oct 25 19:01:02 GMT 2022</span></p> <p><b>Diagnostic Status: Error</b></p> <p>Scientific Instruments: WFC3/UVIS, ACS/WFC</p> <p>Special Requirements: BRIGHT EARTH AVOID 13.5D; ORIENT 302.80D TO 302.80 D; BETWEEN 2022.029:22:49:17 AND 2022.029:22:54:16; BETWEEN 2022.030:22:38:51 AND 2022.030:22:43:50; BETWEEN 2022.031:20:53:05 AND 2022.031:20:58:04; BETWEEN 2022.032:19:07:17 AND 2022.032:19:12:16; BETWEEN 2022.033:20:32:04 AND 2022.033:20:37:03; BETWEEN 2022.034:18:46:14 AND 2022.034:18:51:13; VISIBILITY INTERVAL 5714 S</p> <p><i>Comments: Epoch 6B is a 4-orbit (pseudo)CVZ visit the TTRB has approved as a repeat of lost visit 06, using the opportunity at ORIENT = 300 degrees and WFC3/UVIS as primary. After guide star acquisition at the start of the first orbit, the guide star remains visible and locked for the duration of the visit, so no guide star re-acquisition in subsequent orbits will be required in orbits 2--4. This strategy is the same as adopted for GO-15278 in Cycle 25, and as successfully executed through Cycle 28. Specified POS_TARGs with respect to the nominal field center place the instrument apertures at the intended location within the 13-epoch pattern. While APT throws an error for the specified Bright Earth Avoidance angle of 13.5 degrees, this value is intended, and proven to schedule and execute for a pseudo-CVZ visit. If need be, to facilitate scheduling or guide stars positioning, the specified Orient may be tweaked by a few tenths of a degree in the range 302.50--302.90 deg.</i></p>																
	<b>Diagnostics</b>	<p>(treasurehunt-epoch6Bof13 (6B)) Error (Form): The specified Bright Earth Avoidance angle is outside the permitted range.</p> <p>(treasurehunt-epoch6Bof13 (6B)) Warning (Orbit Planner): NO VISIBILITY TABLE CORRESPONDING TO BRIGHT EARTH AVOIDANCE ANGLE</p> <p>(treasurehunt-epoch6Bof13 (6B)) Warning (Orbit Planner): ORBITAL VISIBILITY OVERRUN</p> <p>(treasurehunt-epoch6Bof13 (6B)) Warning (Orbit Planner): ORBITAL VISIBILITY OVERRUN</p> <p>(treasurehunt-epoch6Bof13 (6B)) Warning (Orbit Planner): ORBITAL VISIBILITY OVERRUN</p> <p>(treasurehunt-epoch6Bof13 (6B)) Warning (Orbit Planner): ORBITAL VISIBILITY OVERRUN</p>															
<b>Fixed Targets</b>		<table border="1" style="width: 100%; border-collapse: collapse;"> <thead> <tr> <th style="width: 5%;">#</th> <th style="width: 20%;">Name</th> <th style="width: 25%;">Target Coordinates</th> <th style="width: 20%;">Targ. Coord. Corrections</th> <th style="width: 10%;">Fluxes</th> <th style="width: 20%;">Miscellaneous</th> </tr> </thead> <tbody> <tr> <td>(4)</td> <td>JWST-NEP-TDF-6BUVIS Alt Name1: WTDF</td> <td>RA: 17 21 52.4777 (260.4686571d) Dec: +65 50 29.34 (65.84148d) Equinox: J2000</td> <td></td> <td>V=27.0+/-1.0</td> <td>Reference Frame: ICRS</td> </tr> </tbody> </table> <p><i>Comments: The target field is centered on the extant HST observations of the JWST NEP Time-Domain Field of GO-15278. Allocated JWST GTO observations will provide both NIRCам imaging and NIRISS slitless spectroscopy in this field, which was defined to be the cleanest ~14' diameter area in JWST's northern continuous viewing zone, where JWST will conduct a deep extragalactic time-domain survey, with added utility for extreme outer solar system and near-Galactic time-domain science. The JWST NEP Time-Domain Field is developed as a *community field*, and has deep coverage accross the electromagnetic spectrum from X-ray through long-wave radio. The present HST program will complete near-contiguous 3-filter coverage in the UV--Visible, targeting the annulus surrounding the extant HST observations of GO-15278.</i></p> <p>Category=UNIDENTIFIED Description=[HIGH LATITUDE FIELD, INFRARED EMITTER, OPTICAL EMITTER, ULTRAVIOLET EMITTER]</p>					#	Name	Target Coordinates	Targ. Coord. Corrections	Fluxes	Miscellaneous	(4)	JWST-NEP-TDF-6BUVIS Alt Name1: WTDF	RA: 17 21 52.4777 (260.4686571d) Dec: +65 50 29.34 (65.84148d) Equinox: J2000		V=27.0+/-1.0
	#	Name	Target Coordinates	Targ. Coord. Corrections	Fluxes	Miscellaneous											
(4)	JWST-NEP-TDF-6BUVIS Alt Name1: WTDF	RA: 17 21 52.4777 (260.4686571d) Dec: +65 50 29.34 (65.84148d) Equinox: J2000		V=27.0+/-1.0	Reference Frame: ICRS												

Proposal 16252 - treasurehunt-epoch6Bof13 (6B) - TREASUREHUNT: Hubble's UV-Visible treasury imaging of the JWST NEP Time...

#	Label (ETC Run)	Target	Config,Mode,Aperture	Spectral Els.	Opt. Params.	Special Reqs.	Groups	Exp. Time (Total)/[Actual Dur.]	Orbit
1	(WFC3UVI S.im.144561 -6BUVIS 3)	(4) JWST-NEP-TDF	WFC3/UVIS, ACCUM, UVIS	F275W	FLASH=16	POS TARG -0.1,0.1	Sequence 1-26 Non-Int in treasurehunt-epoch6Bof13 (6B)  Prime + Parallel Group 1-2 in Sequence 1-26 Non-Int in treasurehunt-epoch6Bof13 (6B)	971 Secs (971 Secs) [==>]	[1]
<p>Comments: Following the June 4 2020 recommendations of J. Anderson (2020) "CURRENT CTE-MITIGATION RECOMMENDATIONS", we aim for a minimum background level of 20 e-/pix in each WFC3/UVIS F275W exposure. Taking into account the raised natural background of this pseudo-CVZ visit, the WFC3/UVIS ETC shows that this requirement becomes satisfied for FLASH=11. The APT Phase-II diagnostics seem to still test the older (now superseded) recommendation of a minimum of only 12 e-/pix, and therefore result in a warning that the specified postflash may be too high.</p>									
2		ANY	ACS/WFC, ACCUM, WFCENTER	F435W			Sequence 1-26 Non-Int in treasurehunt-epoch6Bof13 (6B)  Prime + Parallel Group 1-2 in Sequence 1-26 Non-Int in treasurehunt-epoch6Bof13 (6B)	920 Secs (920 Secs) [==>]	[1]
<p>Comments: The specified POS_TARG values intentionally place the WFC3/UVIS and ACS/WFC instrument apertures off the coordinates of the target (i.e., the center of the JWST NEP Time-Domain Field) to their intended locations within an annulus surrounding the extant HST data.</p>									
3	(WFC3UVI S.im.144561 -6BUVIS 3)	(4) JWST-NEP-TDF	WFC3/UVIS, ACCUM, UVIS	F275W	FLASH=11	POS TARG -0.1,0.1	Sequence 1-26 Non-Int in treasurehunt-epoch6Bof13 (6B)  Prime + Parallel Group 3-5 in Sequence 1-26 Non-Int in treasurehunt-epoch6Bof13 (6B)	2545 Secs (2545 Secs) [==>]	[1]
<p>Comments: Following the June 4 2020 recommendations of J. Anderson (2020) "CURRENT CTE-MITIGATION RECOMMENDATIONS", we aim for a minimum background level of 20 e-/pix in each WFC3/UVIS F275W exposure. Taking into account the raised natural background of this pseudo-CVZ visit, the WFC3/UVIS ETC shows that this requirement becomes satisfied for FLASH=11. The APT Phase-II diagnostics seem to still test the older (now superseded) recommendation of a minimum of only 12 e-/pix, and therefore result in a warning that the specified postflash may be too high.</p>									
4		ANY	ACS/WFC, ACCUM, WFCENTER	F435W			Sequence 1-26 Non-Int in treasurehunt-epoch6Bof13 (6B)  Prime + Parallel Group 3-5 in Sequence 1-26 Non-Int in treasurehunt-epoch6Bof13 (6B)	1170 Secs (1170 Secs) [==>]	[1]
<p>Comments: The specified POS_TARG values intentionally place the WFC3/UVIS and ACS/WFC instrument apertures off the coordinates of the target (i.e., the center of the JWST NEP Time-Domain Field) to their intended locations within an annulus surrounding the extant HST data.</p>									
5		ANY	ACS/WFC, ACCUM, WFCENTER	F606W			Sequence 1-26 Non-Int in treasurehunt-epoch6Bof13 (6B)  Prime + Parallel Group 3-5 in Sequence 1-26 Non-Int in treasurehunt-epoch6Bof13 (6B)	1170 Secs (1170 Secs) [==>]	[1]

Exposures

Proposal 16252 - treasurehunt-epoch6Bof13 (6B) - TREASUREHUNT: Hubble's UV-Visible treasury imaging of the JWST NEP Time...

6	(WFC3UVI (4) JWST-NEP-TDF S.im.144561 -6BUVIS 3)	WFC3/UVIS, ACCUM, UVIS	F275W	FLASH=11	POS TARG 0.1,0.1	Sequence 1-26 Non-Int in treasurehunt-epoch6Bof13 (6B) Prime + Parallel Group 6-8 in Sequence 1-26 Non-Int in treasurehunt-epoch6Bof13 (6B)	2504 Secs (2504 Secs) [==>]	[1]
<p>Comments: Following the June 4 2020 recommendations of J. Anderson (2020) "CURRENT CTE-MITIGATION RECOMMENDATIONS", we aim for a minimum background level of 20 e-/pix in each WFC3/UVIS F275W exposure. Taking into account the raised natural background of this pseudo-CVZ visit, the WFC3/UVIS ETC shows that this requirement becomes satisfied for FLASH=11. The APT Phase-II diagnostics seem to still test the older (now superseded) recommendation of a minimum of only 12 e-/pix, and therefore result in a warning that the specified postflash may be too high.</p>								
7	ANY	ACS/WFC, ACCUM, WFCENTER	F606W			Sequence 1-26 Non-Int in treasurehunt-epoch6Bof13 (6B) Prime + Parallel Group 6-8 in Sequence 1-26 Non-Int in treasurehunt-epoch6Bof13 (6B)	1136 Secs (1136 Secs) [==>]	[1]
<p>Comments: The specified POS_TARG values intentionally place the WFC3/UVIS and ACS/WFC instrument apertures off the coordinates of the target (i.e., the center of the JWST NEP Time-Domain Field) to their intended locations within an annulus surrounding the extant HST data.</p>								
8	ANY	ACS/WFC, ACCUM, WFCENTER	F435W			Sequence 1-26 Non-Int in treasurehunt-epoch6Bof13 (6B) Prime + Parallel Group 6-8 in Sequence 1-26 Non-Int in treasurehunt-epoch6Bof13 (6B)	1136 Secs (1136 Secs) [==>]	[1]
9	(WFC3UVI (4) JWST-NEP-TDF S.im.144561 -6BUVIS 3)	WFC3/UVIS, ACCUM, UVIS	F275W	FLASH=10	POS TARG -0.1,-0.1	Sequence 1-26 Non-Int in treasurehunt-epoch6Bof13 (6B) Prime + Parallel Group 9-11 in Sequence 1-26 Non-Int in treasurehunt-epoch6Bof13 (6B)	2714 Secs (2714 Secs) [==>]	[2]
<p>Comments: Following the June 4 2020 recommendations of J. Anderson (2020) "CURRENT CTE-MITIGATION RECOMMENDATIONS", we aim for a minimum background level of 20 e-/pix in each WFC3/UVIS F275W exposure. Taking into account the raised natural background of this pseudo-CVZ visit, the WFC3/UVIS ETC shows that this requirement becomes satisfied for FLASH=11. The APT Phase-II diagnostics seem to still test the older (now superseded) recommendation of a minimum of only 12 e-/pix, and therefore result in a warning that the specified postflash may be too high.</p>								
10	ANY	ACS/WFC, ACCUM, WFCENTER	F435W			Sequence 1-26 Non-Int in treasurehunt-epoch6Bof13 (6B) Prime + Parallel Group 9-11 in Sequence 1-26 Non-Int in treasurehunt-epoch6Bof13 (6B)	1245 Secs (1245 Secs) [==>]	[2]
<p>Comments: The specified POS_TARG values intentionally place the WFC3/UVIS and ACS/WFC instrument apertures off the coordinates of the target (i.e., the center of the JWST NEP Time-Domain Field) to their intended locations within an annulus surrounding the extant HST data.</p>								
11	ANY	ACS/WFC, ACCUM, WFCENTER	F606W			Sequence 1-26 Non-Int in treasurehunt-epoch6Bof13 (6B) Prime + Parallel Group 9-11 in Sequence 1-26 Non-Int in treasurehunt-epoch6Bof13 (6B)	1245 Secs (1245 Secs) [==>]	[2]

Proposal 16252 - treasurehunt-epoch6Bof13 (6B) - TREASUREHUNT: Hubble's UV-Visible treasury imaging of the JWST NEP Time...

12	(WFC3UVI (4) JWST-NEP-TDF S.im.144561 -6BUVIS 3)	WFC3/UVIS, ACCUM, UVIS	F275W	FLASH=10	POS TARG 0.1,-0.1	Sequence 1-26 Non-Int in treasurehunt-epoch6Bof13 (6B) Prime + Parallel Group 12-14 in Sequence 1-26 Non-Int in treasurehunt-epoch6Bof13 (6B)	2731 Secs (2731 Secs) [==>]	[2]
<p>Comments: Following the June 4 2020 recommendations of J. Anderson (2020) "CURRENT CTE-MITIGATION RECOMMENDATIONS", we aim for a minimum background level of 20 e-/pix in each WFC3/UVIS F275W exposure. Taking into account the raised natural background of this pseudo-CVZ visit, the WFC3/UVIS ETC shows that this requirement becomes satisfied for FLASH=11. The APT Phase-II diagnostics seem to still test the older (now superseded) recommendation of a minimum of only 12 e-/pix, and therefore result in a warning that the specified postflash may be too high.</p>								
13	ANY	ACS/WFC, ACCUM, WFCENTER	F606W			Sequence 1-26 Non-Int in treasurehunt-epoch6Bof13 (6B) Prime + Parallel Group 12-14 in Sequence 1-26 Non-Int in treasurehunt-epoch6Bof13 (6B)	1249 Secs (1249 Secs) [==>]	[2]
<p>Comments: The specified POS_TARG values intentionally place the WFC3/UVIS and ACS/WFC instrument apertures off the coordinates of the target (i.e., the center of the JWST NEP Time-Domain Field) to their intended locations within an annulus surrounding the extant HST data.</p>								
14	ANY	ACS/WFC, ACCUM, WFCENTER	F435W			Sequence 1-26 Non-Int in treasurehunt-epoch6Bof13 (6B) Prime + Parallel Group 12-14 in Sequence 1-26 Non-Int in treasurehunt-epoch6Bof13 (6B)	1250 Secs (1250 Secs) [==>]	[2]
15	(WFC3UVI (4) JWST-NEP-TDF S.im.144561 -6BUVIS 3)	WFC3/UVIS, ACCUM, UVIS	F275W	FLASH=10	POS TARG -0.2,+0.2	Sequence 1-26 Non-Int in treasurehunt-epoch6Bof13 (6B) Prime + Parallel Group 15-17 in Sequence 1-26 Non-Int in treasurehunt-epoch6Bof13 (6B)	2714 Secs (2714 Secs) [==>]	[3]
<p>Comments: Following the June 4 2020 recommendations of J. Anderson (2020) "CURRENT CTE-MITIGATION RECOMMENDATIONS", we aim for a minimum background level of 20 e-/pix in each WFC3/UVIS F275W exposure. Taking into account the raised natural background of this pseudo-CVZ visit, the WFC3/UVIS ETC shows that this requirement becomes satisfied for FLASH=11. The APT Phase-II diagnostics seem to still test the older (now superseded) recommendation of a minimum of only 12 e-/pix, and therefore result in a warning that the specified postflash may be too high.</p>								
16	ANY	ACS/WFC, ACCUM, WFCENTER	F435W			Sequence 1-26 Non-Int in treasurehunt-epoch6Bof13 (6B) Prime + Parallel Group 15-17 in Sequence 1-26 Non-Int in treasurehunt-epoch6Bof13 (6B)	1245 Secs (1245 Secs) [==>]	[3]
<p>Comments: The specified POS_TARG values intentionally place the WFC3/UVIS and ACS/WFC instrument apertures off the coordinates of the target (i.e., the center of the JWST NEP Time-Domain Field) to their intended locations within an annulus surrounding the extant HST data.</p>								
17	ANY	ACS/WFC, ACCUM, WFCENTER	F606W			Sequence 1-26 Non-Int in treasurehunt-epoch6Bof13 (6B) Prime + Parallel Group 15-17 in Sequence 1-26 Non-Int in treasurehunt-epoch6Bof13 (6B)	1245 Secs (1245 Secs) [==>]	[3]

Proposal 16252 - treasurehunt-epoch6Bof13 (6B) - TREASUREHUNT: Hubble's UV-Visible treasury imaging of the JWST NEP Time...

18	(WFC3UVI S.im.144561-3) (4) JWST-NEP-TDF -6BUVIS	WFC3/UVIS, ACCUM, UVIS	F275W	FLASH=10	POS TARG 0,0,2	Sequence 1-26 Non-Int in treasurehunt-epoch6Bof13 (6B) Prime + Parallel Group 18-20 in Sequence 1-26 Non-Int in treasurehunt-epoch6Bof13 (6B)	2731 Secs (2731 Secs) [==>]	[3]
<p>Comments: Following the June 4 2020 recommendations of J. Anderson (2020) "CURRENT CTE-MITIGATION RECOMMENDATIONS", we aim for a minimum background level of 20 e-/pix in each WFC3/UVIS F275W exposure. Taking into account the raised natural background of this pseudo-CVZ visit, the WFC3/UVIS ETC shows that this requirement becomes satisfied for FLASH=11. The APT Phase-II diagnostics seem to still test the older (now superseded) recommendation of a minimum of only 12 e-/pix, and therefore result in a warning that the specified postflash may be too high.</p>								
19	ANY	ACS/WFC, ACCUM, WFCENTER	F606W			Sequence 1-26 Non-Int in treasurehunt-epoch6Bof13 (6B) Prime + Parallel Group 18-20 in Sequence 1-26 Non-Int in treasurehunt-epoch6Bof13 (6B)	1249 Secs (1249 Secs) [==>]	[3]
<p>Comments: The specified POS_TARG values intentionally place the WFC3/UVIS and ACS/WFC instrument apertures off the coordinates of the target (i.e., the center of the JWST NEP Time-Domain Field) to their intended locations within an annulus surrounding the extant HST data.</p>								
20	ANY	ACS/WFC, ACCUM, WFCENTER	F435W			Sequence 1-26 Non-Int in treasurehunt-epoch6Bof13 (6B) Prime + Parallel Group 18-20 in Sequence 1-26 Non-Int in treasurehunt-epoch6Bof13 (6B)	1250 Secs (1250 Secs) [==>]	[3]
21	(WFC3UVI S.im.144564-4) (4) JWST-NEP-TDF -6BUVIS	WFC3/UVIS, ACCUM, UVIS	F275W	FLASH=12	POS TARG -0,2,0	Sequence 1-26 Non-Int in treasurehunt-epoch6Bof13 (6B) Prime + Parallel Group 21-23 in Sequence 1-26 Non-Int in treasurehunt-epoch6Bof13 (6B)	2212 Secs (2212 Secs) [==>]	[4]
<p>Comments: Following the June 4 2020 recommendations of J. Anderson (2020) "CURRENT CTE-MITIGATION RECOMMENDATIONS", we aim for a minimum background level of 20 e-/pix in each WFC3/UVIS F275W exposure. Taking into account the raised natural background of this pseudo-CVZ visit, the WFC3/UVIS ETC shows that this requirement becomes satisfied for FLASH=12. The APT Phase-II diagnostics seem to still test the older (now superseded) recommendation of a minimum of only 12 e-/pix, and therefore result in a warning that the specified postflash may be too high.</p>								
22	ANY	ACS/WFC, ACCUM, WFCENTER	F435W			Sequence 1-26 Non-Int in treasurehunt-epoch6Bof13 (6B) Prime + Parallel Group 21-23 in Sequence 1-26 Non-Int in treasurehunt-epoch6Bof13 (6B)	994 Secs (994 Secs) [==>]	[4]
<p>Comments: The specified POS_TARG values intentionally place the WFC3/UVIS and ACS/WFC instrument apertures off the coordinates of the target (i.e., the center of the JWST NEP Time-Domain Field) to their intended locations within an annulus surrounding the extant HST data.</p>								
23	ANY	ACS/WFC, ACCUM, WFCENTER	F606W			Sequence 1-26 Non-Int in treasurehunt-epoch6Bof13 (6B) Prime + Parallel Group 21-23 in Sequence 1-26 Non-Int in treasurehunt-epoch6Bof13 (6B)	994 Secs (994 Secs) [==>]	[4]

Proposal 16252 - treasurehunt-epoch6Bof13 (6B) - TREASUREHUNT: Hubble's UV-Visible treasury imaging of the JWST NEP Time...

24	(WFC3UVI (4) JWST-NEP-TDF S.im.144564 -6BUVIS 4)	WFC3/UVIS, ACCUM, UVIS	F275W	FLASH=12	POS TARG 0,0	Sequence 1-26 Non-Int in treasurehunt-epoch6Bof13 (6B)  Prime + Parallel Group 24-26 in Sequence 1-26 Non-Int in treasurehunt-epoch6Bof13 (6B)	2190 Secs (2190 Secs)  [==>]	[4]
<p><i>Comments: Following the June 4 2020 recommendations of J. Anderson (2020) "CURRENT CTE-MITIGATION RECOMMENDATIONS", we aim for a minimum background level of 20 e-/pix in each WFC3/UVIS F275W exposure. Taking into account the raised natural background of this pseudo-CVZ visit, the WFC3/UVIS ETC shows that this requirement becomes satisfied for FLASH=12. The APT Phase-II diagnostics seem to still test the older (now superseded) recommendation of a minimum of only 12 e-/pix, and therefore result in a warning that the specified postflash may be too high.</i></p>								
25	ANY	ACS/WFC, ACCUM, WFCENTER	F606W			Sequence 1-26 Non-Int in treasurehunt-epoch6Bof13 (6B)  Prime + Parallel Group 24-26 in Sequence 1-26 Non-Int in treasurehunt-epoch6Bof13 (6B)	993 Secs (993 Secs)  [==>]	[4]
<p><i>Comments: The specified POS_TARG values intentionally place the WFC3/UVIS and ACS/WFC instrument apertures off the coordinates of the target (i.e., the center of the JWST NEP Time-Domain Field) to their intended locations within an annulus surrounding the extant HST data.</i></p>								
26	ANY	ACS/WFC, ACCUM, WFCENTER	F435W			Sequence 1-26 Non-Int in treasurehunt-epoch6Bof13 (6B)  Prime + Parallel Group 24-26 in Sequence 1-26 Non-Int in treasurehunt-epoch6Bof13 (6B)	993 Secs (993 Secs)  [==>]	[4]

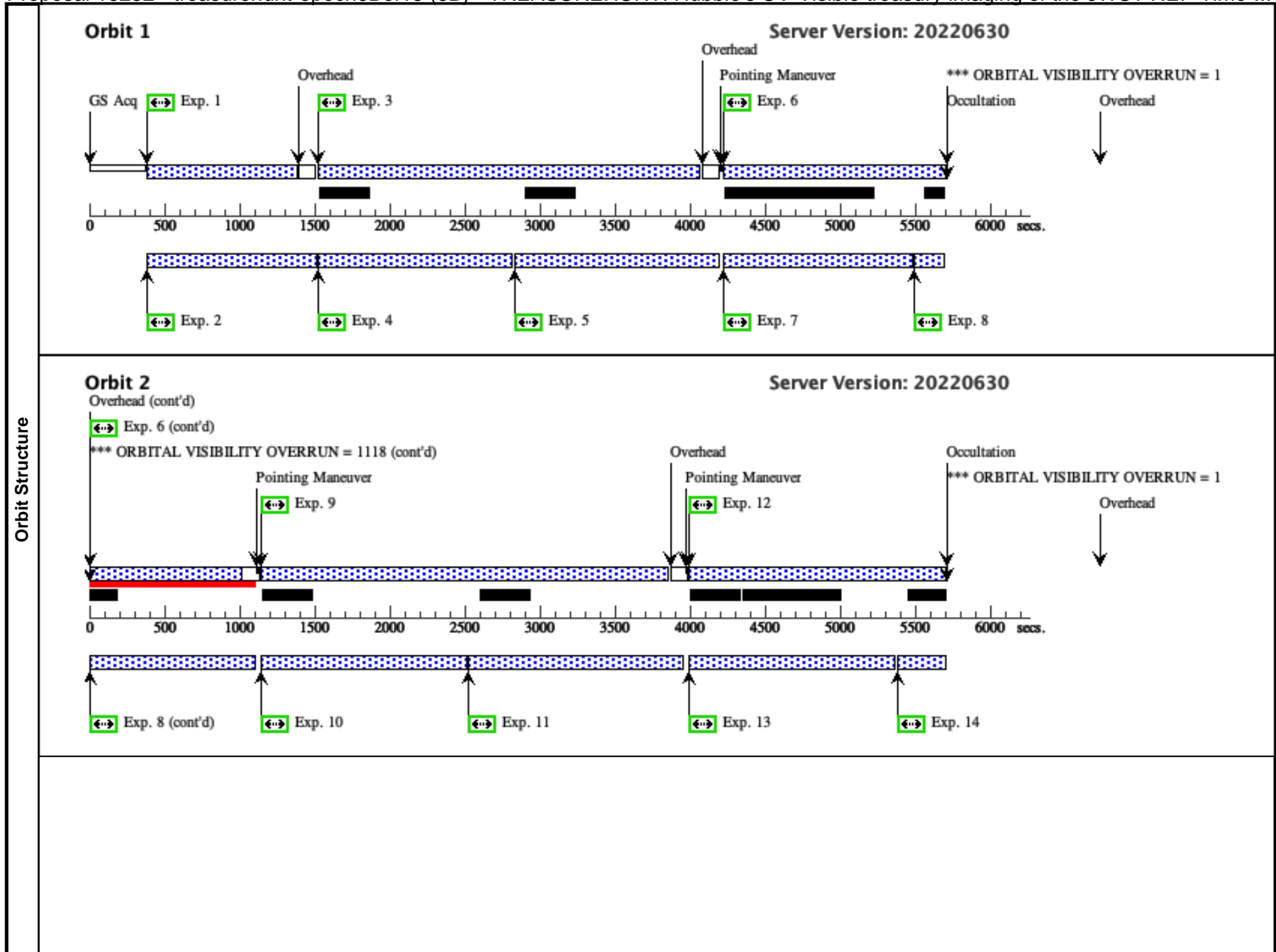

**Orbit 3**

Server Version: 20220630

\*\*\* ORBITAL VISIBILITY OVERRUN = 1118 (cont'd)

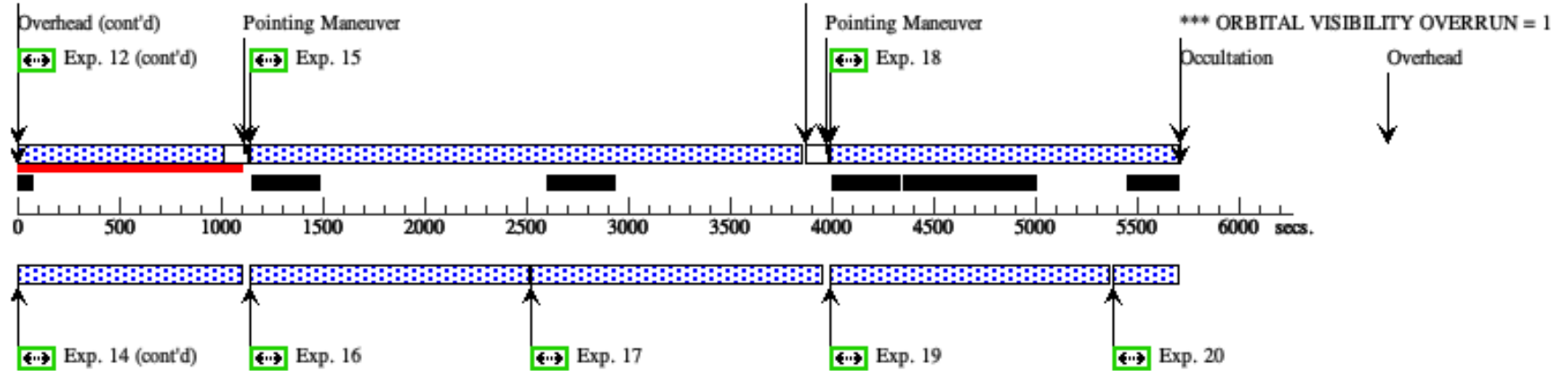

**Orbit 4**

Server Version: 20220630

\*\*\* ORBITAL VISIBILITY OVERRUN = 1118 (cont'd)

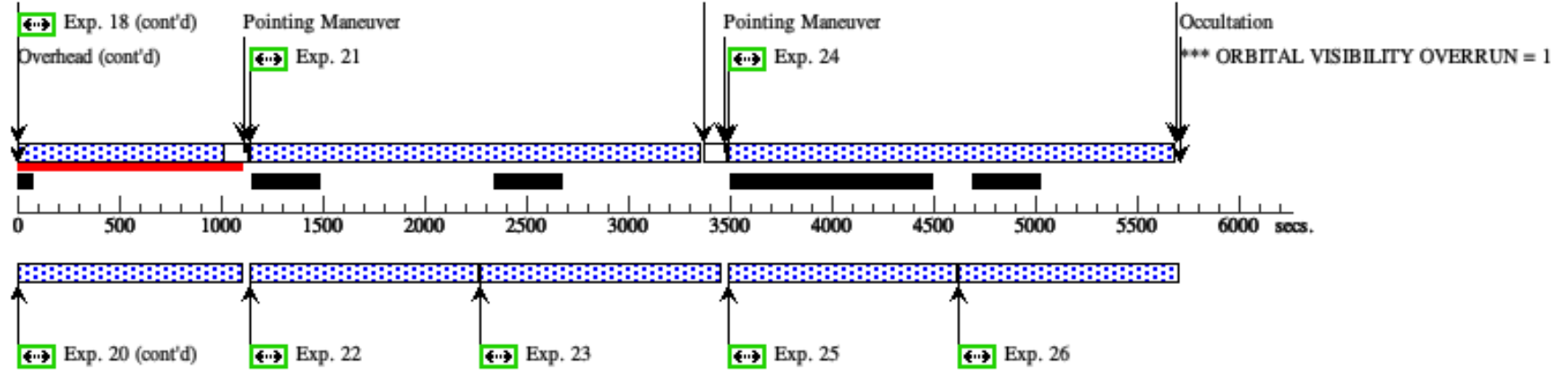

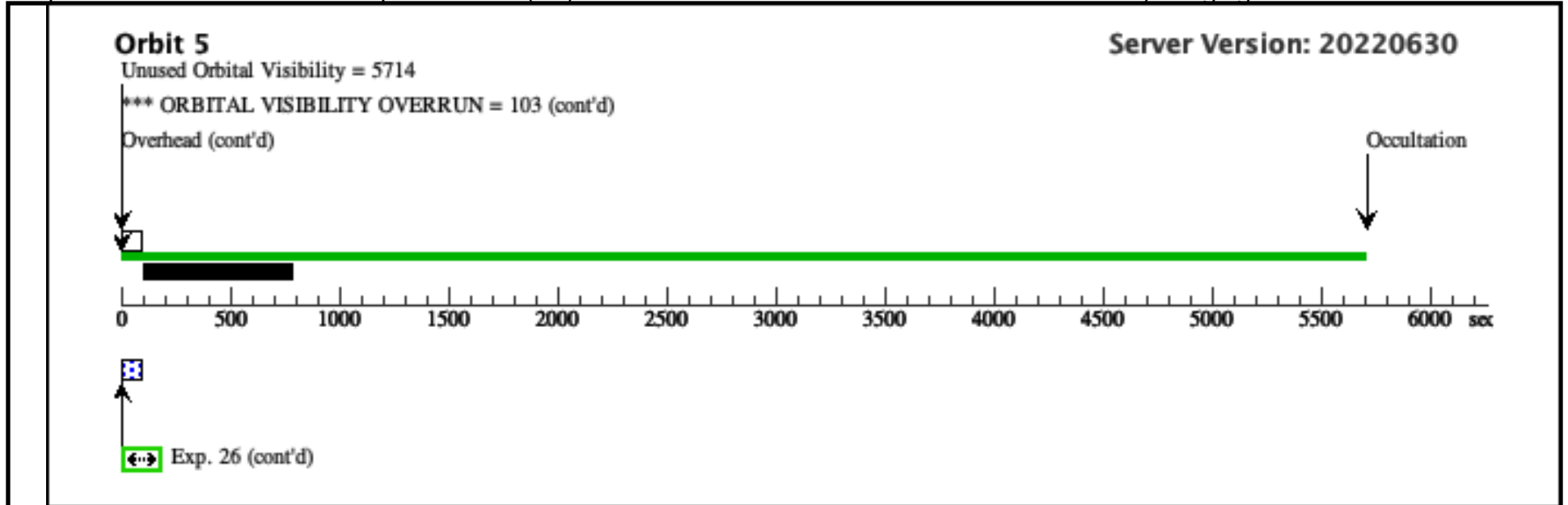



Proposal 16252 - treasurehunt-epoch07of13 (07) - TREASUREHUNT: Hubble's UV-Visible treasury imaging of the JWST NEP Time...

#	Label (ETC Run)	Target	Config,Mode,Aperture	Spectral Els.	Opt. Params.	Special Reqs.	Groups	Exp. Time (Total)/[Actual Dur.]	Orbit
1		(1) JWST-NEP-TDF	ACS/WFC, ACCUM, WFCENTER	F435W		POS TARG -0.100,+ 375.100	Sequence 1-26 Non-Int in treasurehunt-epoch07of13 (07) Prime + Parallel Group 1-2 in Sequence 1-26 Non-Int in treasurehunt-epoch07of13 (07)	1110 Secs (1110 Secs) [==>]	[1]
2	(WFC3UVI ANY S.im.144561 3)		WFC3/UVIS, ACCUM, UVIS	F275W	FLASH=11		Sequence 1-26 Non-Int in treasurehunt-epoch07of13 (07) Prime + Parallel Group 1-2 in Sequence 1-26 Non-Int in treasurehunt-epoch07of13 (07)	1160 Secs (1160 Secs) [==>]	[1]
<p>Comments: Following the June 4 2020 recommendations of J. Anderson (2020) "CURRENT CTE-MITIGATION RECOMMENDATIONS", we aim for a minimum background level of 20 e-/pix in each WFC3/UVIS F275W exposure. Taking into account the raised natural background of this pseudo-CVZ visit, the WFC3/UVIS ETC shows that this requirement becomes satisfied for FLASH=11. The APT Phase-II diagnostics seem to still test the older (now superseded) recommendation of a minimum of only 12 e-/pix, and therefore result in a warning that the specified postflash may be too high.</p>									
3		(1) JWST-NEP-TDF	ACS/WFC, ACCUM, WFCENTER	F435W		POS TARG -0.100,+ 375.100	Sequence 1-26 Non-Int in treasurehunt-epoch07of13 (07) Prime + Parallel Group 3-5 in Sequence 1-26 Non-Int in treasurehunt-epoch07of13 (07)	1136 Secs (1136 Secs) [==>]	[1]
<p>Comments: The specified POS_TARG values intentionally place the WFC3/UVIS and ACS/WFC instrument apertures off the coordinates of the target (i.e., the center of the JWST NEP Time-Domain Field) to their intended locations within an annulus surrounding the extant HST data.</p>									
4		(1) JWST-NEP-TDF	ACS/WFC, ACCUM, WFCENTER	F606W		POS TARG -0.100,+ 375.100	Sequence 1-26 Non-Int in treasurehunt-epoch07of13 (07) Prime + Parallel Group 3-5 in Sequence 1-26 Non-Int in treasurehunt-epoch07of13 (07)	1136 Secs (1136 Secs) [==>]	[1]
5	(WFC3UVI ANY S.im.144561 3)		WFC3/UVIS, ACCUM, UVIS	F275W	FLASH=11		Sequence 1-26 Non-Int in treasurehunt-epoch07of13 (07) Prime + Parallel Group 3-5 in Sequence 1-26 Non-Int in treasurehunt-epoch07of13 (07)	2545 Secs (2545 Secs) [==>]	[1]
<p>Comments: Following the June 4 2020 recommendations of J. Anderson (2020) "CURRENT CTE-MITIGATION RECOMMENDATIONS", we aim for a minimum background level of 20 e-/pix in each WFC3/UVIS F275W exposure. Taking into account the raised natural background of this pseudo-CVZ visit, the WFC3/UVIS ETC shows that this requirement becomes satisfied for FLASH=11. The APT Phase-II diagnostics seem to still test the older (now superseded) recommendation of a minimum of only 12 e-/pix, and therefore result in a warning that the specified postflash may be too high.</p>									

Proposal 16252 - treasurehunt-epoch07of13 (07) - TREASUREHUNT: Hubble's UV-Visible treasury imaging of the JWST NEP Time-...

6	(1) JWST-NEP-TDF ACS/WFC, ACCUM, WFCENTER F606W	POS TARG +0.100, +375.100	Sequence 1-26 Non-Int in treasurehunt-epoch07of13 (07)  Prime + Parallel Group 6-8 in Sequence 1-26 Non-Int in treasurehunt-epoch07of13 (07)	1140 Secs (1140 Secs) [==>]	[1]
<p>Comments: The specified POS_TARG values intentionally place the WFC3/UVIS and ACS/WFC instrument apertures off the coordinates of the target (i.e., the center of the JWST NEP Time-Domain Field) to their intended locations within an annulus surrounding the extant HST data.</p>					
7	(1) JWST-NEP-TDF ACS/WFC, ACCUM, WFCENTER F435W	POS TARG +0.100, +375.100	Sequence 1-26 Non-Int in treasurehunt-epoch07of13 (07)  Prime + Parallel Group 6-8 in Sequence 1-26 Non-Int in treasurehunt-epoch07of13 (07)	1140 Secs (1140 Secs) [==>]	[1]
8	(WFC3UVI ANY S.im.1445613) WFC3/UVIS, ACCUM, UVIS F275W FLASH=11		Sequence 1-26 Non-Int in treasurehunt-epoch07of13 (07)  Prime + Parallel Group 6-8 in Sequence 1-26 Non-Int in treasurehunt-epoch07of13 (07)	2504 Secs (2504 Secs) [==>]	[1]
<p>Comments: Following the June 4 2020 recommendations of J. Anderson (2020) "CURRENT CTE-MITIGATION RECOMMENDATIONS", we aim for a minimum background level of 20 e-/pix in each WFC3/UVIS F275W exposure. Taking into account the raised natural background of this pseudo-CVZ visit, the WFC3/UVIS ETC shows that this requirement becomes satisfied for FLASH=11. The APT Phase-II diagnostics seem to still test the older (now superseded) recommendation of a minimum of only 12 e-/pix, and therefore result in a warning that the specified postflash may be too high.</p>					
9	(1) JWST-NEP-TDF ACS/WFC, ACCUM, WFCENTER F435W	POS TARG -0.100,+ 374.900	Sequence 1-26 Non-Int in treasurehunt-epoch07of13 (07)  Prime + Parallel Group 9-11 in Sequence 1-26 Non-Int in treasurehunt-epoch07of13 (07)	1245 Secs (1245 Secs) [==>]	[2]
<p>Comments: The specified POS_TARG values intentionally place the WFC3/UVIS and ACS/WFC instrument apertures off the coordinates of the target (i.e., the center of the JWST NEP Time-Domain Field) to their intended locations within an annulus surrounding the extant HST data.</p>					
10	(1) JWST-NEP-TDF ACS/WFC, ACCUM, WFCENTER F606W	POS TARG -0.100,+ 374.900	Sequence 1-26 Non-Int in treasurehunt-epoch07of13 (07)  Prime + Parallel Group 9-11 in Sequence 1-26 Non-Int in treasurehunt-epoch07of13 (07)	1245 Secs (1245 Secs) [==>]	[2]
11	(WFC3UVI ANY S.im.1445613) WFC3/UVIS, ACCUM, UVIS F275W FLASH=10		Sequence 1-26 Non-Int in treasurehunt-epoch07of13 (07)  Prime + Parallel Group 9-11 in Sequence 1-26 Non-Int in treasurehunt-epoch07of13 (07)	2714 Secs (2714 Secs) [==>]	[2]
<p>Comments: Following the June 4 2020 recommendations of J. Anderson (2020) "CURRENT CTE-MITIGATION RECOMMENDATIONS", we aim for a minimum background level of 20 e-/pix in each WFC3/UVIS F275W exposure. Taking into account the raised natural background of this pseudo-CVZ visit, the WFC3/UVIS ETC shows that this requirement becomes satisfied for FLASH=11. The APT Phase-II diagnostics seem to still test the older (now superseded) recommendation of a minimum of only 12 e-/pix, and therefore result in a warning that the specified postflash may be too high.</p>					

Proposal 16252 - treasurehunt-epoch07of13 (07) - TREASUREHUNT: Hubble's UV-Visible treasury imaging of the JWST NEP Time...

12	(1) JWST-NEP-TDF ACS/WFC, ACCUM, WFCENTER F606W	POS TARG +0.100, +374.900	Sequence 1-26 Non-Int in treasurehunt-epoch07of13 (07)  Prime + Parallel Group 12-14 in Sequence 1-26 Non-Int in treasurehunt-epoch07of13 (07)	1253 Secs (1253 Secs)  [==>]	[2]
<p><i>Comments: The specified POS_TARG values intentionally place the WFC3/UVIS and ACS/WFC instrument apertures off the coordinates of the target (i.e., the center of the JWST NEP Time-Domain Field) to their intended locations within an annulus surrounding the extant HST data.</i></p>					
13	(1) JWST-NEP-TDF ACS/WFC, ACCUM, WFCENTER F435W	POS TARG +0.100, +374.900	Sequence 1-26 Non-Int in treasurehunt-epoch07of13 (07)  Prime + Parallel Group 12-14 in Sequence 1-26 Non-Int in treasurehunt-epoch07of13 (07)	1254 Secs (1254 Secs)  [==>]	[2]
14	(WFC3UVI ANY S.im.1445613) WFC3/UVIS, ACCUM, UVIS F275W FLASH=10		Sequence 1-26 Non-Int in treasurehunt-epoch07of13 (07)  Prime + Parallel Group 12-14 in Sequence 1-26 Non-Int in treasurehunt-epoch07of13 (07)	2731 Secs (2731 Secs)  [==>]	[2]
<p><i>Comments: Following the June 4 2020 recommendations of J. Anderson (2020) "CURRENT CTE-MITIGATION RECOMMENDATIONS", we aim for a minimum background level of 20 e-/pix in each WFC3/UVIS F275W exposure. Taking into account the raised natural background of this pseudo-CVZ visit, the WFC3/UVIS ETC shows that this requirement becomes satisfied for FLASH=11. The APT Phase-II diagnostics seem to still test the older (now superseded) recommendation of a minimum of only 12 e-/pix, and therefore result in a warning that the specified postflash may be too high.</i></p>					
15	(1) JWST-NEP-TDF ACS/WFC, ACCUM, WFCENTER F435W	POS TARG -0.200,+ 375.200	Sequence 1-26 Non-Int in treasurehunt-epoch07of13 (07)  Prime + Parallel Group 15-17 in Sequence 1-26 Non-Int in treasurehunt-epoch07of13 (07)	1245 Secs (1245 Secs)  [==>]	[3]
<p><i>Comments: The specified POS_TARG values intentionally place the WFC3/UVIS and ACS/WFC instrument apertures off the coordinates of the target (i.e., the center of the JWST NEP Time-Domain Field) to their intended locations within an annulus surrounding the extant HST data.</i></p>					
16	(1) JWST-NEP-TDF ACS/WFC, ACCUM, WFCENTER F606W	POS TARG -0.200,+ 375.200	Sequence 1-26 Non-Int in treasurehunt-epoch07of13 (07)  Prime + Parallel Group 15-17 in Sequence 1-26 Non-Int in treasurehunt-epoch07of13 (07)	1245 Secs (1245 Secs)  [==>]	[3]
17	(WFC3UVI ANY S.im.1445613) WFC3/UVIS, ACCUM, UVIS F275W FLASH=10		Sequence 1-26 Non-Int in treasurehunt-epoch07of13 (07)  Prime + Parallel Group 15-17 in Sequence 1-26 Non-Int in treasurehunt-epoch07of13 (07)	2714 Secs (2714 Secs)  [==>]	[3]
<p><i>Comments: Following the June 4 2020 recommendations of J. Anderson (2020) "CURRENT CTE-MITIGATION RECOMMENDATIONS", we aim for a minimum background level of 20 e-/pix in each WFC3/UVIS F275W exposure. Taking into account the raised natural background of this pseudo-CVZ visit, the WFC3/UVIS ETC shows that this requirement becomes satisfied for FLASH=11. The APT Phase-II diagnostics seem to still test the older (now superseded) recommendation of a minimum of only 12 e-/pix, and therefore result in a warning that the specified postflash may be too high.</i></p>					

Proposal 16252 - treasurehunt-epoch07of13 (07) - TREASUREHUNT: Hubble's UV-Visible treasury imaging of the JWST NEP Time-...

18	(1) JWST-NEP-TDF ACS/WFC, ACCUM, WFCENTER F606W	POS TARG +0.000, +375.200	Sequence 1-26 Non-Int in treasurehunt-epoch07of13 (07)  Prime + Parallel Group 18-20 in Sequence 1-26 Non-Int in treasurehunt-epoch07of13 (07)	1253 Secs (1253 Secs)  [==>]	[3]
<p>Comments: The specified POS_TARG values intentionally place the WFC3/UVIS and ACS/WFC instrument apertures off the coordinates of the target (i.e., the center of the JWST NEP Time-Domain Field) to their intended locations within an annulus surrounding the extant HST data.</p>					
19	(1) JWST-NEP-TDF ACS/WFC, ACCUM, WFCENTER F435W	POS TARG +0.000, +375.200	Sequence 1-26 Non-Int in treasurehunt-epoch07of13 (07)  Prime + Parallel Group 18-20 in Sequence 1-26 Non-Int in treasurehunt-epoch07of13 (07)	1254 Secs (1254 Secs)  [==>]	[3]
20	(WFC3UVI ANY S.im.1445613) WFC3/UVIS, ACCUM, UVIS F275W FLASH=10		Sequence 1-26 Non-Int in treasurehunt-epoch07of13 (07)  Prime + Parallel Group 18-20 in Sequence 1-26 Non-Int in treasurehunt-epoch07of13 (07)	2731 Secs (2731 Secs)  [==>]	[3]
<p>Comments: Following the June 4 2020 recommendations of J. Anderson (2020) "CURRENT CTE-MITIGATION RECOMMENDATIONS", we aim for a minimum background level of 20 e-/pix in each WFC3/UVIS F275W exposure. Taking into account the raised natural background of this pseudo-CVZ visit, the WFC3/UVIS ETC shows that this requirement becomes satisfied for FLASH=11. The APT Phase-II diagnostics seem to still test the older (now superseded) recommendation of a minimum of only 12 e-/pix, and therefore result in a warning that the specified postflash may be too high.</p>					
21	(1) JWST-NEP-TDF ACS/WFC, ACCUM, WFCENTER F435W	POS TARG -0.200,+ 375.000	Sequence 1-26 Non-Int in treasurehunt-epoch07of13 (07)  Prime + Parallel Group 21-23 in Sequence 1-26 Non-Int in treasurehunt-epoch07of13 (07)	994 Secs (994 Secs)  [==>]	[4]
<p>Comments: The specified POS_TARG values intentionally place the WFC3/UVIS and ACS/WFC instrument apertures off the coordinates of the target (i.e., the center of the JWST NEP Time-Domain Field) to their intended locations within an annulus surrounding the extant HST data.</p>					
22	(1) JWST-NEP-TDF ACS/WFC, ACCUM, WFCENTER F606W	POS TARG -0.200,+ 375.000	Sequence 1-26 Non-Int in treasurehunt-epoch07of13 (07)  Prime + Parallel Group 21-23 in Sequence 1-26 Non-Int in treasurehunt-epoch07of13 (07)	994 Secs (994 Secs)  [==>]	[4]
23	(WFC3UVI ANY S.im.1445644) WFC3/UVIS, ACCUM, UVIS F275W FLASH=12		Sequence 1-26 Non-Int in treasurehunt-epoch07of13 (07)  Prime + Parallel Group 21-23 in Sequence 1-26 Non-Int in treasurehunt-epoch07of13 (07)	2212 Secs (2212 Secs)  [==>]	[4]
<p>Comments: Following the June 4 2020 recommendations of J. Anderson (2020) "CURRENT CTE-MITIGATION RECOMMENDATIONS", we aim for a minimum background level of 20 e-/pix in each WFC3/UVIS F275W exposure. Taking into account the raised natural background of this pseudo-CVZ visit, the WFC3/UVIS ETC shows that this requirement becomes satisfied for FLASH=12. The APT Phase-II diagnostics seem to still test the older (now superseded) recommendation of a minimum of only 12 e-/pix, and therefore result in a warning that the specified postflash may be too high.</p>					

Proposal 16252 - treasurehunt-epoch07of13 (07) - TREASUREHUNT: Hubble's UV-Visible treasury imaging of the JWST NEP Time-...

24	(1) JWST-NEP-TDF ACS/WFC, ACCUM, WFCENTER F606W	POS TARG +0.000, +375.000	Sequence 1-26 Non-Int in treasurehunt-epoch07of13 (07)  Prime + Parallel Group 24-26 in Sequence 1-26 Non-Int in treasurehunt-epoch07of13 (07)	997 Secs (997 Secs)	[==>]	[4]
<p><i>Comments: The specified POS_TARG values intentionally place the WFC3/UVIS and ACS/WFC instrument apertures off the coordinates of the target (i.e., the center of the JWST NEP Time-Domain Field) to their intended locations within an annulus surrounding the extant HST data.</i></p>						
25	(1) JWST-NEP-TDF ACS/WFC, ACCUM, WFCENTER F435W	POS TARG +0.000, +375.000	Sequence 1-26 Non-Int in treasurehunt-epoch07of13 (07)  Prime + Parallel Group 24-26 in Sequence 1-26 Non-Int in treasurehunt-epoch07of13 (07)	997 Secs (997 Secs)	[==>]	[4]
26	(WFC3UVI ANY S.im.1445644) WFC3/UVIS, ACCUM, UVIS F275W FLASH=12		Sequence 1-26 Non-Int in treasurehunt-epoch07of13 (07)  Prime + Parallel Group 24-26 in Sequence 1-26 Non-Int in treasurehunt-epoch07of13 (07)	2198 Secs (2198 Secs)	[==>]	[4]
<p><i>Comments: Following the June 4 2020 recommendations of J. Anderson (2020) "CURRENT CTE-MITIGATION RECOMMENDATIONS", we aim for a minimum background level of 20 e-/pix in each WFC3/UVIS F275W exposure. Taking into account the raised natural background of this pseudo-CVZ visit, the WFC3/UVIS ETC shows that this requirement becomes satisfied for FLASH=12. The APT Phase-II diagnostics seem to still test the older (now superseded) recommendation of a minimum of only 12 e-/pix, and therefore result in a warning that the specified postflash may be too high.</i></p>						

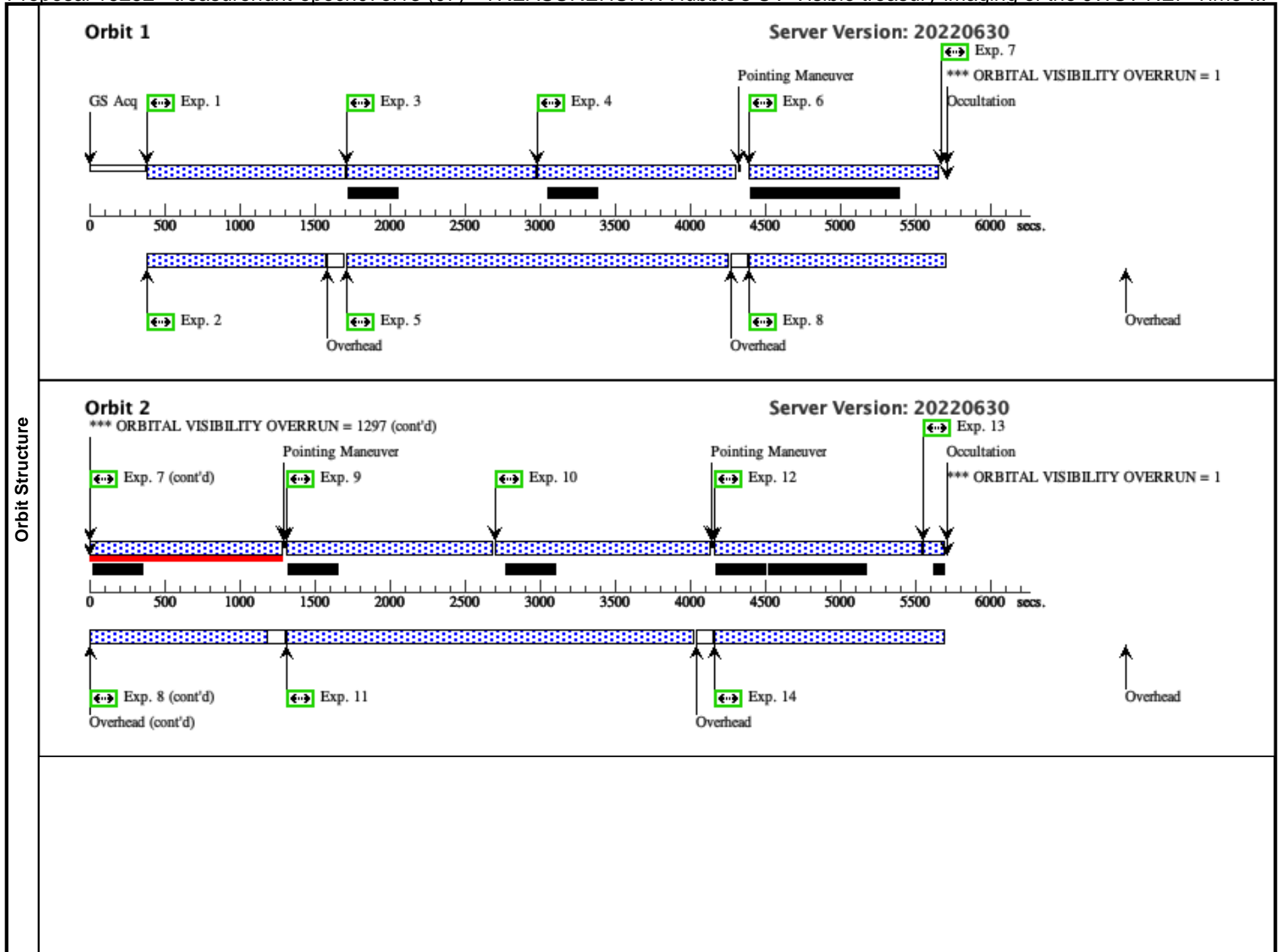

**Orbit 3**

Server Version: 20220630

\*\*\* ORBITAL VISIBILITY OVERRUN = 1297 (cont'd)

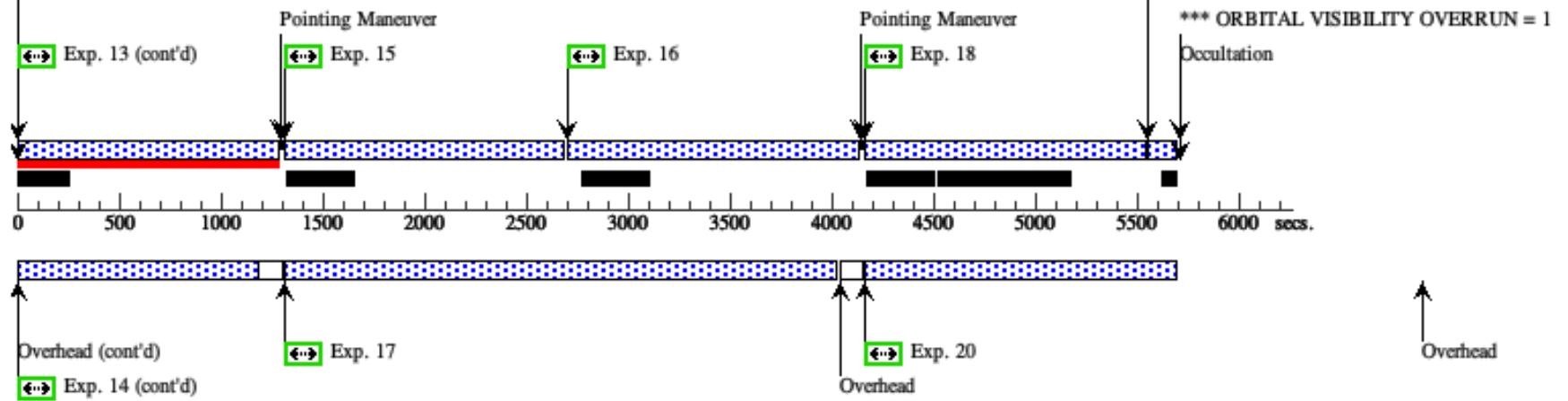

**Orbit 4**

Server Version: 20220630

\*\*\* ORBITAL VISIBILITY OVERRUN = 1297 (cont'd)

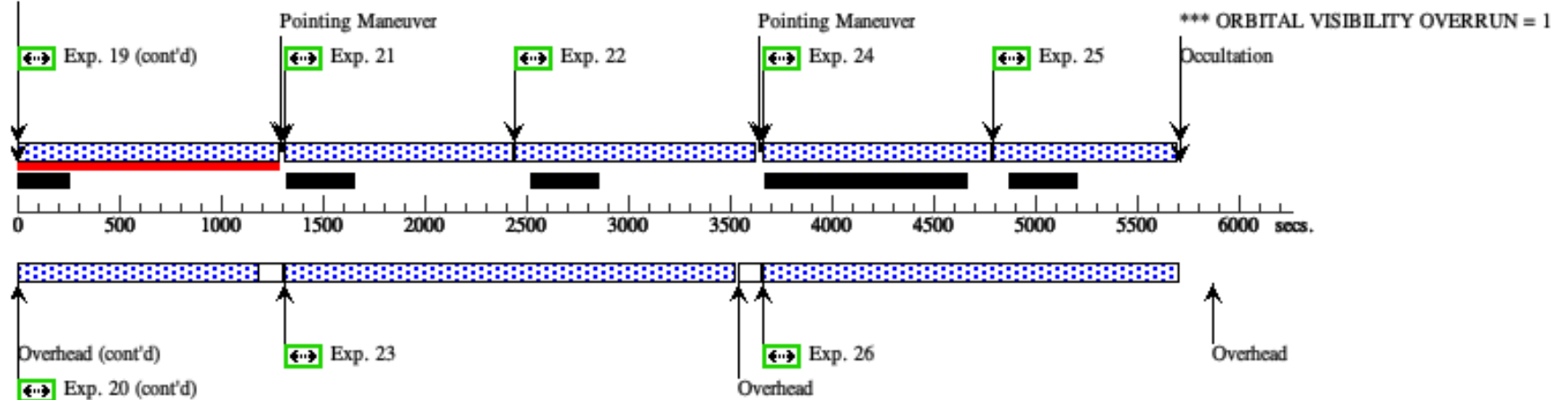

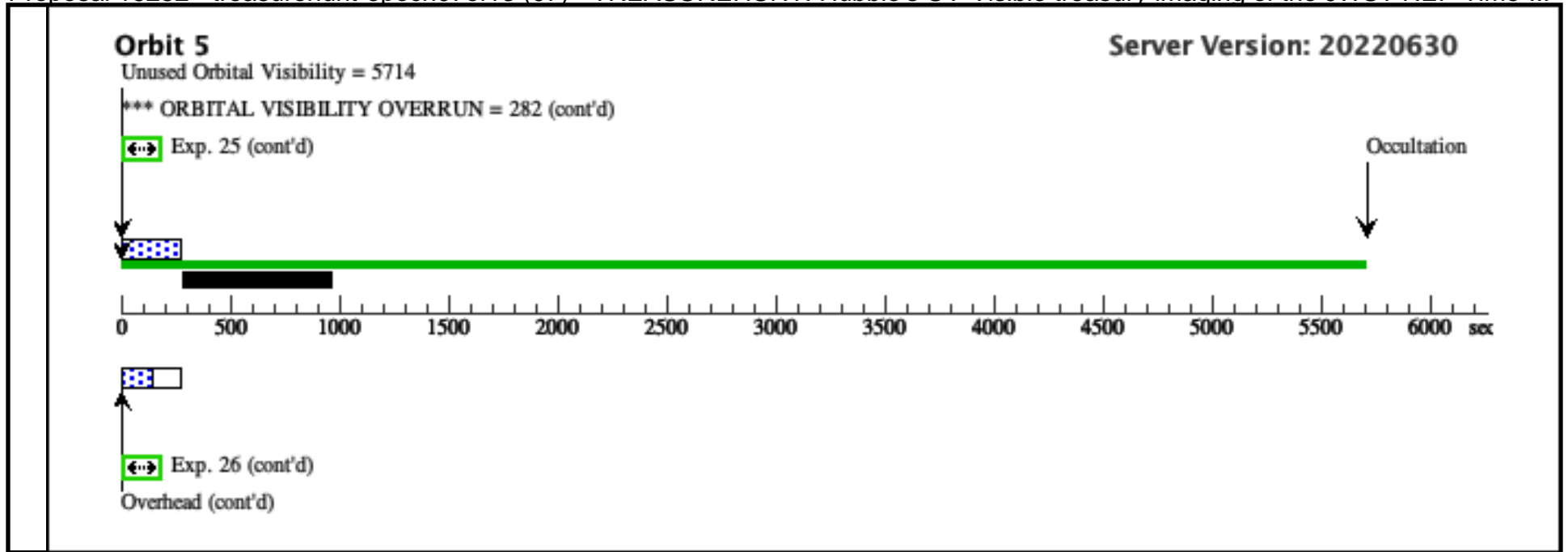

Proposal 16252 - treasurehunt-epoch1Bof13 (08) - TREASUREHUNT: Hubble's UV-Visible treasury imaging of the JWST NEP Time-...

<b>Visit</b>	<p><b>Proposal 16252, treasurehunt-epoch1Bof13 (08), completed</b> <span style="float: right;">Tue Oct 25 19:01:02 GMT 2022</span></p> <p><b>Diagnostic Status: Error</b></p> <p>Scientific Instruments: WFC3/UVIS, ACS/WFC</p> <p>Special Requirements: BRIGHT EARTH AVOID 13.5D; ORIENT 023D TO 023 D; ORIENT 269D TO 269 D; ORIENT 216D TO 216 D; ORIENT 059.5D TO 059.5 D; ORIENT 003D TO 003 D; ORIENT 244D TO 244 D; ORIENT 191D TO 191 D; ORIENT 147D TO 147 D; BETWEEN 2021.122:13:16:40 AND 2021.122:13:22:40; BETWEEN 2021.123:13:06:25 AND 2021.123:13:12:25; BETWEEN 2021.124:12:56:13 AND 2021.124:13:02:13; BETWEEN 2021.125:12:46:03 AND 2021.125:12:52:03; BETWEEN 2021.126:11:00:35 AND 2021.126:11:06:35; BETWEEN 2021.127:10:50:27 AND 2021.127:10:56:27; BETWEEN 2021.128:10:40:20 AND 2021.128:10:46:20; VISIBILITY INTERVAL 5714 S</p> <p><i>Comments: Epoch 1B of 13 is a 4-orbit (pseudo)CVZ visit, repeating Visit 01 that was misaligned due to guidestar issues and only imaged the ACS/WFC field at the intended location. This visit will obtain the associated WFC3/UVIS by specific targeting to place WFC3/UVIS at the intended location within the 13-epoch pattern, at any of several CVZ-compatible ORIENTs. After guide star acquisition at the start of the first orbit, the guide star remains visible and locked for the duration of the visit, so no guide star re-acquisition in subsequent orbits will be required in orbits 2--4. This strategy is the same as adopted for GO-15278 in Cycle 25, and as successfully executed through Cycle 27. While APT throws an error for the specified Bright Earth Avoidance angle of 13.5 degrees, this value is intended and proven to schedule and execute for a pseudo-CVZ visit.</i></p>																
	<b>Diagnostics</b>	<p>(treasurehunt-epoch1Bof13 (08)) Error (Form): The specified Bright Earth Avoidance angle is outside the permitted range.</p> <p>(treasurehunt-epoch1Bof13 (08)) Warning (Orbit Planner): NO VISIBILITY TABLE CORRESPONDING TO BRIGHT EARTH AVOIDANCE ANGLE</p> <p>(treasurehunt-epoch1Bof13 (08)) Warning (Orbit Planner): ORBITAL VISIBILITY OVERRUN</p> <p>(treasurehunt-epoch1Bof13 (08)) Warning (Orbit Planner): ORBITAL VISIBILITY OVERRUN</p> <p>(treasurehunt-epoch1Bof13 (08)) Warning (Orbit Planner): ORBITAL VISIBILITY OVERRUN</p>															
<b>Fixed Targets</b>		<table border="1" style="width: 100%; border-collapse: collapse;"> <thead> <tr> <th style="width: 5%;">#</th> <th style="width: 20%;">Name</th> <th style="width: 25%;">Target Coordinates</th> <th style="width: 20%;">Targ. Coord. Corrections</th> <th style="width: 10%;">Fluxes</th> <th style="width: 20%;">Miscellaneous</th> </tr> </thead> <tbody> <tr> <td>(3)</td> <td>JWST-NEP-TDF-1BUVIS Alt Name1: WTDF</td> <td>RA: 17 22 26.9030 (260.6120958d) Dec: +65 43 21.65 (65.72268d) Equinox: J2000</td> <td></td> <td>V=27.0+/-1.0</td> <td>Reference Frame: ICRS</td> </tr> </tbody> </table> <p><i>Comments: The target field is centered on the extant HST observations of the JWST NEP Time-Domain Field of GO-15278. Allocated JWST GTO observations will provide both NIRCам imaging and NIRISS slitless spectroscopy in this field, which was defined to be the cleanest ~14' diameter area in JWST's northern continuous viewing zone, where JWST will conduct a deep extragalactic time-domain survey, with added utility for extreme outer solar system and near-Galactic time-domain science. The JWST NEP Time-Domain Field is developed as a *community field*, and has deep coverage accross the electromagnetic spectrum from X-ray through long-wave radio. The present HST program will complete near-contiguous 3-filter coverage in the UV--Visible, targeting the annulus surrounding the extant HST observations of GO-15278.</i></p> <p>Category=UNIDENTIFIED Description=[HIGH LATITUDE FIELD, INFRARED EMITTER, OPTICAL EMITTER, ULTRAVIOLET EMITTER]</p>					#	Name	Target Coordinates	Targ. Coord. Corrections	Fluxes	Miscellaneous	(3)	JWST-NEP-TDF-1BUVIS Alt Name1: WTDF	RA: 17 22 26.9030 (260.6120958d) Dec: +65 43 21.65 (65.72268d) Equinox: J2000		V=27.0+/-1.0
	#	Name	Target Coordinates	Targ. Coord. Corrections	Fluxes	Miscellaneous											
(3)	JWST-NEP-TDF-1BUVIS Alt Name1: WTDF	RA: 17 22 26.9030 (260.6120958d) Dec: +65 43 21.65 (65.72268d) Equinox: J2000		V=27.0+/-1.0	Reference Frame: ICRS												

Proposal 16252 - treasurehunt-epoch1Bof13 (08) - TREASUREHUNT: Hubble's UV-Visible treasury imaging of the JWST NEP Time...

#	Label (ETC Run)	Target	Config,Mode,Aperture	Spectral Els.	Opt. Params.	Special Reqs.	Groups	Exp. Time (Total)/[Actual Dur.]	Orbit
1		(3) JWST-NEP-TDF -1BUVIS	WFC3/UVIS, ACCUM, UVIS	F275W	FLASH=19	POS TARG -0.1,0.1	Sequence 1-26 Non-Int in treasurehunt-epoch1Bof13 (08)  Prime + Parallel Group 1-2 in Sequence 1-26 Non-Int in treasurehunt-epoch1Bof13 (08)	550 Secs (550 Secs) [==>]	[1]
2		ANY	ACS/WFC, ACCUM, WFCENTER	F435W			Sequence 1-26 Non-Int in treasurehunt-epoch1Bof13 (08)  Prime + Parallel Group 1-2 in Sequence 1-26 Non-Int in treasurehunt-epoch1Bof13 (08)	500 Secs (500 Secs) [==>]	[1]
3	(WFC3UVIS.im.1445613)	(3) JWST-NEP-TDF -1BUVIS	WFC3/UVIS, ACCUM, UVIS	F275W	FLASH=11	POS TARG -0.1,0.1	Sequence 1-26 Non-Int in treasurehunt-epoch1Bof13 (08)  Prime + Parallel Group 3-5 in Sequence 1-26 Non-Int in treasurehunt-epoch1Bof13 (08)	2545 Secs (2545 Secs) [==>]	[1]
<p><i>Comments: Following the June 4 2020 recommendations of J. Anderson (2020) "CURRENT CTE-MITIGATION RECOMMENDATIONS", we aim for a minimum background level of 20 e-/pix in each WFC3/UVIS F275W exposure. Taking into account the raised natural background of this pseudo-CVZ visit, the WFC3/UVIS ETC shows that this requirement becomes satisfied for FLASH=11. The APT Phase-II diagnostics seem to still test the older (now superseded) recommendation of a minimum of only 12 e-/pix, and therefore result in a warning that the specified postflash may be too high.</i></p>									
4		ANY	ACS/WFC, ACCUM, WFCENTER	F435W			Sequence 1-26 Non-Int in treasurehunt-epoch1Bof13 (08)  Prime + Parallel Group 3-5 in Sequence 1-26 Non-Int in treasurehunt-epoch1Bof13 (08)	1160 Secs (1160 Secs) [==>]	[1]
<p><i>Comments: The specified POS_TARG values intentionally place the WFC3/UVIS and ACS/WFC instrument apertures off the coordinates of the target (i.e., the center of the JWST NEP Time-Domain Field) to their intended locations within an annulus surrounding the extant HST data.</i></p>									
5		ANY	ACS/WFC, ACCUM, WFCENTER	F606W			Sequence 1-26 Non-Int in treasurehunt-epoch1Bof13 (08)  Prime + Parallel Group 3-5 in Sequence 1-26 Non-Int in treasurehunt-epoch1Bof13 (08)	1160 Secs (1160 Secs) [==>]	[1]
6	(WFC3UVIS.im.1445613)	(3) JWST-NEP-TDF -1BUVIS	WFC3/UVIS, ACCUM, UVIS	F275W	FLASH=11	POS TARG +0.1,+0.1	Sequence 1-26 Non-Int in treasurehunt-epoch1Bof13 (08)  Prime + Parallel Group 6-8 in Sequence 1-26 Non-Int in treasurehunt-epoch1Bof13 (08)	2504 Secs (2504 Secs) [==>]	[1]
<p><i>Comments: Following the June 4 2020 recommendations of J. Anderson (2020) "CURRENT CTE-MITIGATION RECOMMENDATIONS", we aim for a minimum background level of 20 e-/pix in each WFC3/UVIS F275W exposure. Taking into account the raised natural background of this pseudo-CVZ visit, the WFC3/UVIS ETC shows that this requirement becomes satisfied for FLASH=11. The APT Phase-II diagnostics seem to still test the older (now superseded) recommendation of a minimum of only 12 e-/pix, and therefore result in a warning that the specified postflash may be too high.</i></p>									

Proposal 16252 - treasurehunt-epoch1Bof13 (08) - TREASUREHUNT: Hubble's UV-Visible treasury imaging of the JWST NEP Time...

7	ANY	ACS/WFC, ACCUM, WFCENTER	F606W				Sequence 1-26 Non-Int in treasurehunt-epoch1Bof13 (08) Prime + Parallel Group 6-8 in Sequence 1-26 Non-Int in treasurehunt-epoch1Bof13 (08)	1140 Secs (1140 Secs) [==>]	[1]
<p>Comments: The specified POS_TARG values intentionally place the WFC3/UVIS and ACS/WFC instrument apertures off the coordinates of the target (i.e., the center of the JWST NEP Time-Domain Field) to their intended locations within an annulus surrounding the extant HST data.</p>									
8	ANY	ACS/WFC, ACCUM, WFCENTER	F435W				Sequence 1-26 Non-Int in treasurehunt-epoch1Bof13 (08) Prime + Parallel Group 6-8 in Sequence 1-26 Non-Int in treasurehunt-epoch1Bof13 (08)	1140 Secs (1140 Secs) [==>]	[1]
9	(WFC3UVIS (3) JWST-NEP-TDF S.im.144561 -1BUVIS 3)	WFC3/UVIS, ACCUM, UVIS	F275W	FLASH=11	POS TARG -0.1,-0.1		Sequence 1-26 Non-Int in treasurehunt-epoch1Bof13 (08) Prime + Parallel Group 9-11 in Sequence 1-26 Non-Int in treasurehunt-epoch1Bof13 (08)	2714 Secs (2714 Secs) [==>]	[2]
<p>Comments: Following the June 4 2020 recommendations of J. Anderson (2020) "CURRENT CTE-MITIGATION RECOMMENDATIONS", we aim for a minimum background level of 20 e-/pix in each WFC3/UVIS F275W exposure. Taking into account the raised natural background of this pseudo-CVZ visit, the WFC3/UVIS ETC shows that this requirement becomes satisfied for FLASH=11. The APT Phase-II diagnostics seem to still test the older (now superseded) recommendation of a minimum of only 12 e-/pix, and therefore result in a warning that the specified postflash may be too high.</p>									
10	ANY	ACS/WFC, ACCUM, WFCENTER	F435W				Sequence 1-26 Non-Int in treasurehunt-epoch1Bof13 (08) Prime + Parallel Group 9-11 in Sequence 1-26 Non-Int in treasurehunt-epoch1Bof13 (08)	1245 Secs (1245 Secs) [==>]	[2]
<p>Comments: The specified POS_TARG values intentionally place the WFC3/UVIS and ACS/WFC instrument apertures off the coordinates of the target (i.e., the center of the JWST NEP Time-Domain Field) to their intended locations within an annulus surrounding the extant HST data.</p>									
11	ANY	ACS/WFC, ACCUM, WFCENTER	F606W				Sequence 1-26 Non-Int in treasurehunt-epoch1Bof13 (08) Prime + Parallel Group 9-11 in Sequence 1-26 Non-Int in treasurehunt-epoch1Bof13 (08)	1245 Secs (1245 Secs) [==>]	[2]
12	(WFC3UVIS (3) JWST-NEP-TDF S.im.144561 -1BUVIS 3)	WFC3/UVIS, ACCUM, UVIS	F275W	FLASH=11	POS TARG +0.1,-0.1		Sequence 1-26 Non-Int in treasurehunt-epoch1Bof13 (08) Prime + Parallel Group 12-14 in Sequence 1-26 Non-Int in treasurehunt-epoch1Bof13 (08)	2731 Secs (2731 Secs) [==>]	[2]
<p>Comments: Following the June 4 2020 recommendations of J. Anderson (2020) "CURRENT CTE-MITIGATION RECOMMENDATIONS", we aim for a minimum background level of 20 e-/pix in each WFC3/UVIS F275W exposure. Taking into account the raised natural background of this pseudo-CVZ visit, the WFC3/UVIS ETC shows that this requirement becomes satisfied for FLASH=11. The APT Phase-II diagnostics seem to still test the older (now superseded) recommendation of a minimum of only 12 e-/pix, and therefore result in a warning that the specified postflash may be too high.</p>									

Proposal 16252 - treasurehunt-epoch1Bof13 (08) - TREASUREHUNT: Hubble's UV-Visible treasury imaging of the JWST NEP Time-...

13	ANY	ACS/WFC, ACCUM, WFCENTER	F606W				Sequence 1-26 Non-Int in treasurehunt-epoch1Bof13 (08) Prime + Parallel Group 12-14 in Sequence 1-26 Non-Int in treasurehunt-epoch1Bof13 (08)	1253 Secs (1253 Secs) [==>]	[2]
<p><i>Comments: The specified POS_TARG values intentionally place the WFC3/UVIS and ACS/WFC instrument apertures off the coordinates of the target (i.e., the center of the JWST NEP Time-Domain Field) to their intended locations within an annulus surrounding the extant HST data.</i></p>									
14	ANY	ACS/WFC, ACCUM, WFCENTER	F435W				Sequence 1-26 Non-Int in treasurehunt-epoch1Bof13 (08) Prime + Parallel Group 12-14 in Sequence 1-26 Non-Int in treasurehunt-epoch1Bof13 (08)	1254 Secs (1254 Secs) [==>]	[2]
15	(WFC3UVIS (3) JWST-NEP-TDF S.im.144561 -1BUVIS 3)	WFC3/UVIS, ACCUM, UVIS	F275W	FLASH=11	POS TARG -0.2,+0.2		Sequence 1-26 Non-Int in treasurehunt-epoch1Bof13 (08) Prime + Parallel Group 15-17 in Sequence 1-26 Non-Int in treasurehunt-epoch1Bof13 (08)	2714 Secs (2714 Secs) [==>]	[3]
<p><i>Comments: Following the June 4 2020 recommendations of J. Anderson (2020) "CURRENT CTE-MITIGATION RECOMMENDATIONS", we aim for a minimum background level of 20 e-/pix in each WFC3/UVIS F275W exposure. Taking into account the raised natural background of this pseudo-CVZ visit, the WFC3/UVIS ETC shows that this requirement becomes satisfied for FLASH=11. The APT Phase-II diagnostics seem to still test the older (now superseded) recommendation of a minimum of only 12 e-/pix, and therefore result in a warning that the specified postflash may be too high.</i></p>									
16	ANY	ACS/WFC, ACCUM, WFCENTER	F435W				Sequence 1-26 Non-Int in treasurehunt-epoch1Bof13 (08) Prime + Parallel Group 15-17 in Sequence 1-26 Non-Int in treasurehunt-epoch1Bof13 (08)	1245 Secs (1245 Secs) [==>]	[3]
<p><i>Comments: The specified POS_TARG values intentionally place the WFC3/UVIS and ACS/WFC instrument apertures off the coordinates of the target (i.e., the center of the JWST NEP Time-Domain Field) to their intended locations within an annulus surrounding the extant HST data.</i></p>									
17	ANY	ACS/WFC, ACCUM, WFCENTER	F606W				Sequence 1-26 Non-Int in treasurehunt-epoch1Bof13 (08) Prime + Parallel Group 15-17 in Sequence 1-26 Non-Int in treasurehunt-epoch1Bof13 (08)	1245 Secs (1245 Secs) [==>]	[3]
18	(WFC3UVIS (3) JWST-NEP-TDF S.im.144561 -1BUVIS 3)	WFC3/UVIS, ACCUM, UVIS	F275W	FLASH=11	POS TARG +0.0,+0.2		Sequence 1-26 Non-Int in treasurehunt-epoch1Bof13 (08) Prime + Parallel Group 18-20 in Sequence 1-26 Non-Int in treasurehunt-epoch1Bof13 (08)	2731 Secs (2731 Secs) [==>]	[3]
<p><i>Comments: Following the June 4 2020 recommendations of J. Anderson (2020) "CURRENT CTE-MITIGATION RECOMMENDATIONS", we aim for a minimum background level of 20 e-/pix in each WFC3/UVIS F275W exposure. Taking into account the raised natural background of this pseudo-CVZ visit, the WFC3/UVIS ETC shows that this requirement becomes satisfied for FLASH=11. The APT Phase-II diagnostics seem to still test the older (now superseded) recommendation of a minimum of only 12 e-/pix, and therefore result in a warning that the specified postflash may be too high.</i></p>									

Proposal 16252 - treasurehunt-epoch1Bof13 (08) - TREASUREHUNT: Hubble's UV-Visible treasury imaging of the JWST NEP Time...

19	ANY	ACS/WFC, ACCUM, WFCENTER	F606W				Sequence 1-26 Non-Int in treasurehunt-epoch1Bof13 (08) Prime + Parallel Group 18-20 in Sequence 1-26 Non-Int in treasurehunt-epoch1Bof13 (08)	1253 Secs (1253 Secs) [==>]	[3]
<p>Comments: The specified POS_TARG values intentionally place the WFC3/UVIS and ACS/WFC instrument apertures off the coordinates of the target (i.e., the center of the JWST NEP Time-Domain Field) to their intended locations within an annulus surrounding the extant HST data.</p>									
20	ANY	ACS/WFC, ACCUM, WFCENTER	F435W				Sequence 1-26 Non-Int in treasurehunt-epoch1Bof13 (08) Prime + Parallel Group 18-20 in Sequence 1-26 Non-Int in treasurehunt-epoch1Bof13 (08)	1254 Secs (1254 Secs) [==>]	[3]
21	(WFC3UVI (3) JWST-NEP-TDF S.im.144564 -1BUVIS 4)	WFC3/UVIS, ACCUM, UVIS	F275W	FLASH=12	POS TARG -0.2,+0.0		Sequence 1-26 Non-Int in treasurehunt-epoch1Bof13 (08) Prime + Parallel Group 21-23 in Sequence 1-26 Non-Int in treasurehunt-epoch1Bof13 (08)	2212 Secs (2212 Secs) [==>]	[4]
<p>Comments: Following the June 4 2020 recommendations of J. Anderson (2020) "CURRENT CTE-MITIGATION RECOMMENDATIONS", we aim for a minimum background level of 20 e-/pix in each WFC3/UVIS F275W exposure. Taking into account the raised natural background of this pseudo-CVZ visit, the WFC3/UVIS ETC shows that this requirement becomes satisfied for FLASH=12. The APT Phase-II diagnostics seem to still test the older (now superseded) recommendation of a minimum of only 12 e-/pix, and therefore result in a warning that the specified postflash may be too high.</p>									
22	ANY	ACS/WFC, ACCUM, WFCENTER	F435W				Sequence 1-26 Non-Int in treasurehunt-epoch1Bof13 (08) Prime + Parallel Group 21-23 in Sequence 1-26 Non-Int in treasurehunt-epoch1Bof13 (08)	994 Secs (994 Secs) [==>]	[4]
<p>Comments: The specified POS_TARG values intentionally place the WFC3/UVIS and ACS/WFC instrument apertures off the coordinates of the target (i.e., the center of the JWST NEP Time-Domain Field) to their intended locations within an annulus surrounding the extant HST data.</p>									
23	ANY	ACS/WFC, ACCUM, WFCENTER	F606W				Sequence 1-26 Non-Int in treasurehunt-epoch1Bof13 (08) Prime + Parallel Group 21-23 in Sequence 1-26 Non-Int in treasurehunt-epoch1Bof13 (08)	994 Secs (994 Secs) [==>]	[4]
24	(WFC3UVI (3) JWST-NEP-TDF S.im.144564 -1BUVIS 4)	WFC3/UVIS, ACCUM, UVIS	F275W	FLASH=12	POS TARG +0.0,+0.0		Sequence 1-26 Non-Int in treasurehunt-epoch1Bof13 (08) Prime + Parallel Group 24-26 in Sequence 1-26 Non-Int in treasurehunt-epoch1Bof13 (08)	2198 Secs (2198 Secs) [==>]	[4]
<p>Comments: Following the June 4 2020 recommendations of J. Anderson (2020) "CURRENT CTE-MITIGATION RECOMMENDATIONS", we aim for a minimum background level of 20 e-/pix in each WFC3/UVIS F275W exposure. Taking into account the raised natural background of this pseudo-CVZ visit, the WFC3/UVIS ETC shows that this requirement becomes satisfied for FLASH=12. The APT Phase-II diagnostics seem to still test the older (now superseded) recommendation of a minimum of only 12 e-/pix, and therefore result in a warning that the specified postflash may be too high.</p>									

Proposal 16252 - treasurehunt-epoch1Bof13 (08) - TREASUREHUNT: Hubble's UV-Visible treasury imaging of the JWST NEP Time-...

25	ANY	ACS/WFC, ACCUM, WFCENTER F606W	Sequence 1-26 Non-Int in treasurehunt-epoch1Bof13 (08) Prime + Parallel Group 24-26 in Sequence 1-26 Non-Int in treasurehunt-epoch1Bof13 (08)	997 Secs (997 Secs) [==>]	[4]
<p><i>Comments: The specified POS_TARG values intentionally place the WFC3/UVIS and ACS/WFC instrument apertures off the coordinates of the target (i.e., the center of the JWST NEP Time-Domain Field) to their intended locations within an annulus surrounding the extant HST data.</i></p>					
26	ANY	ACS/WFC, ACCUM, WFCENTER F435W	Sequence 1-26 Non-Int in treasurehunt-epoch1Bof13 (08) Prime + Parallel Group 24-26 in Sequence 1-26 Non-Int in treasurehunt-epoch1Bof13 (08)	997 Secs (997 Secs) [==>]	[4]

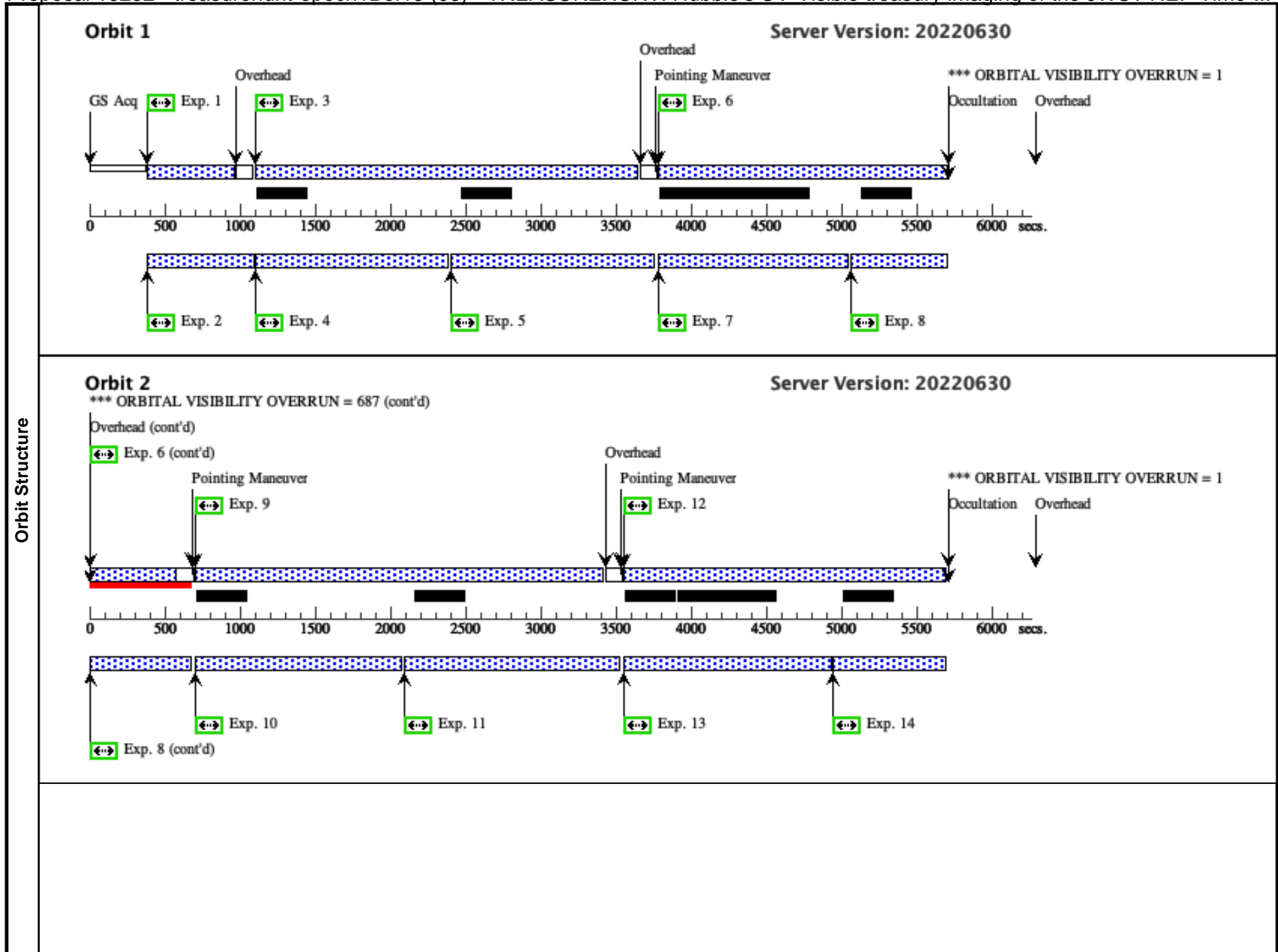

### Orbit 3

Server Version: 20220630

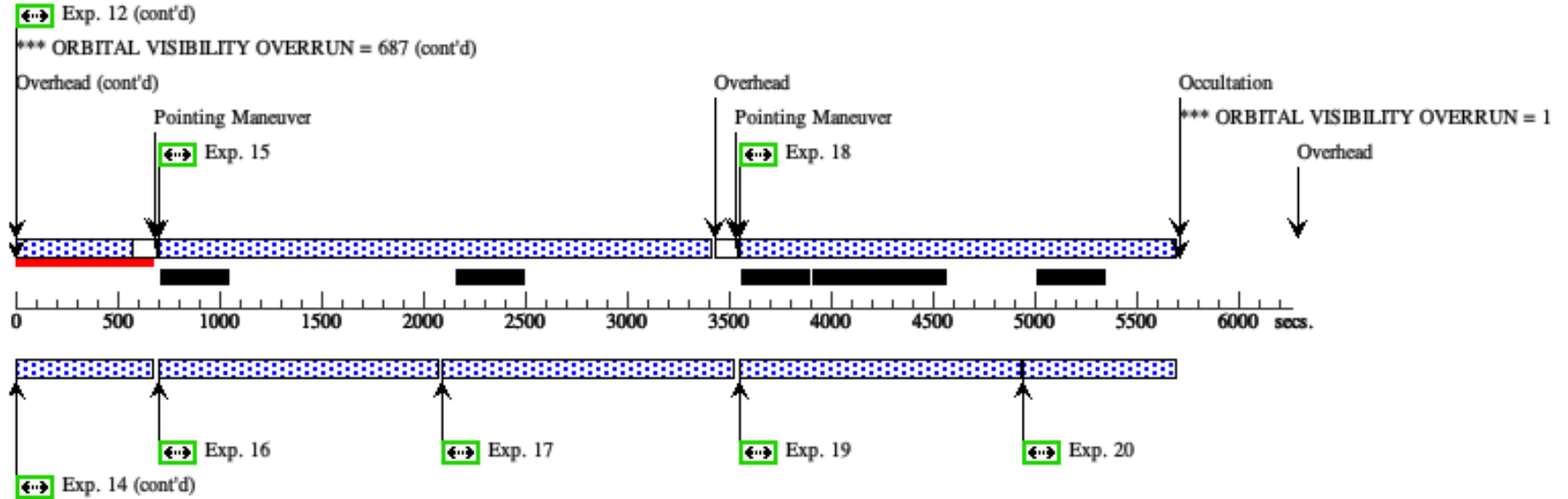

### Orbit 4

Server Version: 20220630

