



16793 - TREASUREHUNT: Hubble's UV-Visible treasury imaging of the JWST NEP Time-Domain Field

Cycle: 29, Proposal Category: GO

(Availability Mode: AVAILABLE)

INVESTIGATORS

<i>Name</i>	<i>Institution</i>	<i>E-Mail</i>
Dr. Rolf A. Jansen (PI) (Contact)	Arizona State University	rolf.jansen@asu.edu
Dr. Norman Grogin (CoI) (Contact)	Space Telescope Science Institute	nagrogin@stsci.edu
Prof. Rogier A. Windhorst (CoI)	Arizona State University	rogier.windhorst@asu.edu
Dr. Christopher Nicholas Andrew Willmer (CoI)	University of Arizona	cnav@as.arizona.edu
Dr. Teresa Ann Ashcraft (CoI)	University of Tampa	tashcraft@ut.edu
Dr. Silvia Bonoli (CoI) (ESA Member)	Centro de Estudios de Física del Cosmos de Aragon	silvia.bonoli@dipc.org
Dr. Walter Brisken (CoI)	Associated Universities, Inc.	wbrisken@nrao.edu
Dr. Seth H. Cohen (CoI)	Arizona State University	seth.cohen@asu.edu
Prof. Christopher Conselice (CoI) (ESA Member)	University of Manchester	conselice@gmail.com
Dr. William Cotton (CoI)	Associated Universities, Inc.	bcotton@nrao.edu
Prof. Vik Dhillon (CoI) (ESA Member)	University of Sheffield	vik.dhillon@sheffield.ac.uk
Prof. Simon P. Driver (CoI)	University of Western Australia	simon.driver@icrar.org
Dr. Kenneth James Duncan (CoI) (ESA Member)	University of Edinburgh, Institute for Astronomy	kdun@roe.ac.uk
Dr. Renato A. Dupke (CoI)	Eureka Scientific Inc.	rdupke@umich.edu
Prof. Steven L. Finkelstein (CoI)	University of Texas at Austin	stevenf@astro.as.utexas.edu
Prof. Brenda Louise Frye (CoI)	University of Arizona	bfrye@as.arizona.edu
Mr. Alex Griffiths (CoI) (ESA Member)	University of Nottingham	alex.griffiths@nottingham.ac.uk
Dr. Nimish P. Hathi (CoI)	Space Telescope Science Institute	nhathi@stsci.edu
Ms. Victoria R Jones (CoI)	University of Arizona	vrjones@email.arizona.edu
Dr. Duho Kim (CoI)	Korea Astronomy and Space Science Institute (KASI)	dhkim@kasi.re.kr

Proposal 16793 (STScI Edit Number: 15, Created: Thursday, June 30, 2022 at 10:00:44 AM Eastern Standard Time) - Overview

<i>Name</i>	<i>Institution</i>	<i>E-Mail</i>
Dr. Anton M. Koekemoer (CoI)	Space Telescope Science Institute	koekemoer@stsci.edu
Ms. Rebecca L. Larson (CoI)	University of Texas at Austin	rlarson@astro.as.utexas.edu
Dr. Walter Peter Maksym III (CoI)	Smithsonian Institution Astrophysical Observatory	peter.maksym@gmail.com
Dr. Madeline Marshall (CoI) (CSA Member)	Dominion Astrophysical Observatory	madeline_marshall@outlook.com
Dr. Hugo Messias (CoI) (ESA Member)	European Southern Observatory - Chile	hugo.messias@alma.cl
Dr. Stefanie N. Milam (CoI)	NASA Goddard Space Flight Center	stefanie.n.milam@nasa.gov
Dr. Richard A. Perley (CoI)	Associated Universities, Inc.	rperley@nrao.edu
Dr. Steve Rodney (CoI)	University of South Carolina	steve.rodney@gmail.com
Dr. Michael James Rutkowski (CoI)	Minnesota State University, Mankato	michael.rutkowski@mnsu.edu
Dr. Russell E. Ryan Jr. (CoI)	Space Telescope Science Institute	rryan@stsci.edu
Prof. Ian Smail (CoI) (ESA Member)	Durham Univ.	ian.smail@durham.ac.uk
Dr. Brent Matthew Smith (CoI)	Arizona State University	brent.smith.1@asu.edu
Mr. Cameron W. White (CoI)	University of Arizona	cwwhite@email.arizona.edu
Dr. Nico Cappelluti (CoI)	University of Miami	nicocappelluti@gmail.com
Prof. Myungshin Im (CoI)	Seoul National University	myungshin.im@gmail.com
Dr. Mehmet Alpaslan (CoI)	New York University	mehmet.alpaslan@nyu.edu
Prof. Huub Rottgering (CoI) (ESA Member)	Universiteit Leiden	rottgering@strw.leidenuniv.nl
Dr. Matthew L. N. Ashby (CoI)	Smithsonian Institution Astrophysical Observatory	mashby@cfa.harvard.edu
Dr. Giovanni G. Fazio (CoI)	Smithsonian Institution Astrophysical Observatory	gfazio@cfa.harvard.edu
Prof. Martin J. Ward (CoI) (ESA Member)	Durham Univ.	martin.ward@durham.ac.uk
Dr. Heidi B. Hammel (CoI)	Space Science Institute	hbhammel@aura-astronomy.org
Dr. Martin Elvis (CoI)	Smithsonian Institution Astrophysical Observatory	elvis@cfa.harvard.edu
Dr. Francesca Civano (CoI)	Smithsonian Institution Astrophysical Observatory	fcivano@cfa.harvard.edu
Dr. Bilal Ladjelate (CoI) (ESA Member)	Institut De Radioastronomie Millimetrique (IRAM)	ladjelate@iram.es
Dr. Sangeeta Malhotra (CoI)	NASA Goddard Space Flight Center	sangeeta.malhotra@nasa.gov
Dr. Reinout Johannes van Weeren (CoI) (ESA Member)	Universiteit Leiden	rvweeren@strw.leidenuniv.nl
Dr. James Rhoads (CoI)	NASA Goddard Space Flight Center	james.e.rhoads@nasa.gov
Dr. Minhee Hyun (CoI)	Seoul National University	minhee@astro.snu.ac.kr

VISITS

<i>Visit</i>	<i>Targets used in Visit</i>	<i>Configurations used in Visit</i>	<i>Orbits Used</i>	<i>Last Orbit Planner Run</i>	<i>OP Current with Visit?</i>
01	(1) JWST-NEP-TDF ANY	ACS/WFC WFC3/UVIS	5	01-Dec-2021 12:51:02.0	yes
02	(1) JWST-NEP-TDF ANY	ACS/WFC WFC3/UVIS	5	30-Jun-2022 11:00:29.0	yes
03	(1) JWST-NEP-TDF ANY	ACS/WFC WFC3/UVIS	5	30-Jun-2022 11:00:33.0	yes
04	(1) JWST-NEP-TDF ANY	ACS/WFC WFC3/UVIS	4	30-Jun-2022 11:00:36.0	yes
05	(1) JWST-NEP-TDF ANY	ACS/WFC WFC3/UVIS	5	30-Jun-2022 11:00:39.0	yes
06	(1) JWST-NEP-TDF ANY	ACS/WFC WFC3/UVIS	5	30-Jun-2022 11:00:43.0	yes

29 Total Orbits Used

ABSTRACT

We propose to complete the near-contiguous UV-Visible imaging of the JWST NEP Time-Domain Field, the best field within the JWST Continuous Viewing Zones to conduct deep and wide extragalactic JWST surveys at arbitrary cadence or orientation. This recently developed, ~14' diameter time-domain field near the North Ecliptic Pole (1) is devoid of sources brighter than $m_{AB} \sim 16$ mag at 2-4 micron that would deeply saturate JWST/NIRCam, (2) has the lowest possible zodiacal foreground, (3) has low Galactic foreground extinction, and (4) has a wealth of deep ground- and space-based ancillary data from X-ray through radio. Deep UV-Visible HST imaging to $m_{AB} \sim 28$ mag exists for the inner ~9' diameter portion of this field. Completing the coverage of the NEP Time-Domain Field to the same depth, in combination with extant data, allows the community to:

- (1) Establish a baseline UV-Visible detection image at $\sim 0.07''$ FWHM at wavelengths inaccessible to JWST, and map transients and moving objects in areas of 2- and 3-epoch overlap;
- (2) Identify rest-frame UV-bright objects at $z < 6$ that would contaminate JWST ultra-high- z galaxy samples;
- (3) Identify galaxies with steep intrinsic UV-Visible SEDs indicative of (weak)AGN, assess the escape of LyC photons at $2 < z < 3$, and place limits on that escape and IGM porosity at $z < \sim 3.5$; and
- (4) Study mass assembly and evolution of all significantly resolved UV-bright galaxies at $z < 6$ on a 'pixel-by-pixel' basis.

In order to maximize the scientific return of early-release JWST science, it is critical to image this field in the UV-Visible while HST is still in its prime and before commencement of JWST observations in 2022.

OBSERVING DESCRIPTION

This treasury program was allocated 28 primary plus 28 parallel orbits in Cycle 28, and 24 primary plus 24 parallel orbits in Cycle 29, and aims to complete near-contiguous 3-filter UV--visible HST imaging of the JWST North Ecliptic Pole (NEP) Time-Domain Field, for which allocated GTO observations will provide both NIRCam 8-band imaging and NIRISS slitless spectroscopy at four distinct "spokes". JWST ERS and GO observers will have access to the GTO data, so we anticipate time-domain follow-up as early as JWST Cycle 1, as well as additional areal coverage within this field. The JWST NEP Time-Domain Field was defined to be the cleanest ~14' diameter area in JWST's northern Continuous Viewing Zone (CVZ), where JWST can conduct a deep extragalactic time-domain survey, with added utility for extreme outer solar system and near-Galactic time-domain science. The present program, GO-16252+GO-16793, builds directly on Cycle 25 program GO-15278, which covered the inner ~5' diameter portion of the field, by imaging an annulus surrounding the extant observations to very similar depths. We aim to minimize both gaps between new and extant data, and overlap with those extant data, while maximizing use of (pseudo)CVZ opportunities in Cycle 28 and 29. To maximize (1) overall HST coverage of the JWST NEP Time-Domain Field, (2) overlap of the UV coverage of WFC3/UVIS F275W and visible coverage of ACS/WFC F435W and F606W, and (3) execute this program as efficiently as possible, we specify seven (Cycle 28) + six (Cycle 29) 4-orbit visits using (pseudo)CVZ orbits with orientations and POS TARG offsets such that WFC3/UVIS F275W observations at one orientation will largely overlap ACS/WFC F435W and F606W observations at an alternate orientation in our overall pattern. This observational design brings our program to the total of 52 primary and 52 coordinated parallel orbits approved in Phase I. Through experimentation in Cycle 25 Phase II, we found that the visits optimize better when we define the ACS/WFC observations as primary and the WFC3/UVIS observations as coordinated parallels. This does not change the intent or scope of this program. The final detailed layout takes into account the availability of suitable guide stars for each visit, which forced a slight offset of ~30" of visit #1 with respect to the ideal pointing. While we designed the detailed observations for the full Cycle 28+29 program, this Phase-II APT of GO-16793 covers only Cycle 29, i.e., the final 6 out of 13 visits.

Proposal 16793 - treasurehunt-epochA8of13 (01) - TREASUREHUNT: Hubble's UV-Visible treasury imaging of the JWST NEP Time-...

Visit	<p>Proposal 16793, treasurehunt-epochA8of13 (01), completed Thu Jun 30 15:00:44 GMT 2022</p> <p>Diagnostic Status: Error</p> <p>Scientific Instruments: WFC3/UVIS, ACS/WFC</p> <p>Special Requirements: BRIGHT EARTH AVOID 13.5D; ORIENT 061.1D TO 061.75 D; BETWEEN 2021.285:03:19:22 AND 2021.285:03:25:22; BETWEEN 2021.286:03:08:58 AND 2021.286:03:14:59; BETWEEN 2021.287:02:58:35 AND 2021.287:03:04:35; BETWEEN 2021.288:02:48:13 AND 2021.288:02:54:13; BETWEEN 2021.289:02:37:53 AND 2021.289:02:43:53; BETWEEN 2021.290:00:52:17 AND 2021.290:00:58:17; VISIBILITY INTERVAL 5714 S</p> <p><i>Comments: Copy of Epoch 08 of 13 is a 4-orbit (pseudo)CVZ visit, using the opportunity at alternative ORIENT = 061.75 degrees. After guide star acquisition at the start of the first orbit, the guide star remains visible and locked for the duration of the visit, so no guide star re-acquisition in subsequent orbits will be required in orbits 2--4. This strategy is the same as adopted for GO-15278 in Cycle 25, and as successfully executed through Cycle 28. Specified POS_TARGs with respect to the nominal field center place the instrument apertures at the intended location within the 13-epoch pattern. While APT throws an error for the specified Bright Earth Avoidance angle of 13.5 degrees, this value is intended, and proven to schedule and execute successfully for a pseudo-CVZ visit.</i></p>																
	Diagnostics	<p>(treasurehunt-epochA8of13 (01)) Error (Form): The specified Bright Earth Avoidance angle is outside the permitted range.</p> <p>(Parallel Exposure 2 (Prime + Parallel Group 1-2 in Sequence 1-26 Non-Int in treasurehunt-epochA8of13 (01))) Warning (Form): FLASH level may be too low for this exposure or a short subexposure. See extended explanation in the diagnostic browser</p>															
Fixed Targets	<table border="1" style="width: 100%; border-collapse: collapse;"> <thead> <tr> <th style="width: 5%;">#</th> <th style="width: 20%;">Name</th> <th style="width: 25%;">Target Coordinates</th> <th style="width: 20%;">Targ. Coord. Corrections</th> <th style="width: 15%;">Fluxes</th> <th style="width: 15%;">Miscellaneous</th> </tr> </thead> <tbody> <tr> <td>(1)</td> <td>JWST-NEP-TDF</td> <td>RA: 17 22 47.8960 (260.6995667d) Dec: +65 49 21.54 (65.82265d) Equinox: J2000</td> <td></td> <td>V=27.0+/-1.0</td> <td>Reference Frame: ICRS</td> </tr> </tbody> </table>					#	Name	Target Coordinates	Targ. Coord. Corrections	Fluxes	Miscellaneous	(1)	JWST-NEP-TDF	RA: 17 22 47.8960 (260.6995667d) Dec: +65 49 21.54 (65.82265d) Equinox: J2000		V=27.0+/-1.0	Reference Frame: ICRS
	#	Name	Target Coordinates	Targ. Coord. Corrections	Fluxes	Miscellaneous											
(1)	JWST-NEP-TDF	RA: 17 22 47.8960 (260.6995667d) Dec: +65 49 21.54 (65.82265d) Equinox: J2000		V=27.0+/-1.0	Reference Frame: ICRS												
<p><i>Comments: The target field is centered on the extant HST observations of the JWST NEP Time-Domain Field of GO-15278. Allocated JWST GTO observations will provide both NIRCам imaging and NIRISS slitless spectroscopy in this field, which was defined to be the cleanest ~14' diameter area in JWST's northern continuous viewing zone, where JWST will conduct a deep extragalactic time-domain survey, with added utility for extreme outer solar system and near-Galactic time-domain science. The JWST NEP Time-Domain Field is developed as a *community field*, and has deep coverage across the electromagnetic spectrum from X-ray through long-wave radio. The present Cycle 28+29 HST program will complete near-contiguous 3-filter coverage in the UV-Visible, targeting the annulus surrounding the extant HST observations of GO-15278. The present Phase-II APT specifies the Cycle 29 pointings within that annulus.</i></p> <p>Category=UNIDENTIFIED Description=[HIGH LATITUDE FIELD, INFRARED EMITTER, OPTICAL EMITTER, ULTRAVIOLET EMITTER]</p>																	

Proposal 16793 - treasurehunt-epochA8of13 (01) - TREASUREHUNT: Hubble's UV-Visible treasury imaging of the JWST NEP Time...

#	Label (ETC Run)	Target	Config,Mode,Aperture	Spectral Els.	Opt. Params.	Special Reqs.	Groups	Exp. Time (Total)/[Actual Dur.]	Orbit
1		(1) JWST-NEP-TDF	ACS/WFC, ACCUM, WFCENTER	F435W		POS TARG 10.100, +345.100	Sequence 1-26 Non-Int in treasurehunt-epochA8of13 (01) Prime + Parallel Group 1-2 in Sequence 1-26 Non-Int in treasurehunt-epochA8of13 (01)	680 Secs (680 Secs) [==>]	[1]
<p><i>Comments: The specified POS_TARG values intentionally place the WFC3/UVIS and ACS/WFC instrument apertures off the coordinates of the target (i.e., the center of the JWST NEP Time-Domain Field) to their intended locations within an annulus surrounding the extant HST data.</i></p>									
2	(WFC3UVIS im.1445613)	ANY	WFC3/UVIS, ACCUM, UVIS	F275W	FLASH=12		Sequence 1-26 Non-Int in treasurehunt-epochA8of13 (01) Prime + Parallel Group 1-2 in Sequence 1-26 Non-Int in treasurehunt-epochA8of13 (01)	733 Secs (733 Secs) [==>]	[1]
<p><i>Comments: Following the June 4 2020 recommendations of J. Anderson (2020) "CURRENT CTE-MITIGATION RECOMMENDATIONS", we aim for a minimum background level of 20 e-/pix in each WFC3/UVIS F275W exposure. Taking into account the raised natural background of this pseudo-CVZ visit, the WFC3/UVIS ETC shows that this requirement becomes satisfied for FLASH=11. The APT Phase-II diagnostics seem to still test the older (now superseded) recommendation of a minimum of only 12 e-/pix, and therefore result in a warning that the specified postflash may be too high.</i></p>									
3		(1) JWST-NEP-TDF	ACS/WFC, ACCUM, WFCENTER	F435W		POS TARG 10.100, +345.100	Sequence 1-26 Non-Int in treasurehunt-epochA8of13 (01) Prime + Parallel Group 3-5 in Sequence 1-26 Non-Int in treasurehunt-epochA8of13 (01)	1136 Secs (1136 Secs) [==>]	[1]
<p><i>Comments: The specified POS_TARG values intentionally place the WFC3/UVIS and ACS/WFC instrument apertures off the coordinates of the target (i.e., the center of the JWST NEP Time-Domain Field) to their intended locations within an annulus surrounding the extant HST data.</i></p>									
4		(1) JWST-NEP-TDF	ACS/WFC, ACCUM, WFCENTER	F606W		POS TARG 10.100, +345.100	Sequence 1-26 Non-Int in treasurehunt-epochA8of13 (01) Prime + Parallel Group 3-5 in Sequence 1-26 Non-Int in treasurehunt-epochA8of13 (01)	1136 Secs (1136 Secs) [==>]	[1]
5	(WFC3UVIS im.1445613)	ANY	WFC3/UVIS, ACCUM, UVIS	F275W	FLASH=11		Sequence 1-26 Non-Int in treasurehunt-epochA8of13 (01) Prime + Parallel Group 3-5 in Sequence 1-26 Non-Int in treasurehunt-epochA8of13 (01)	2500 Secs (2500 Secs) [==>]	[1]
<p><i>Comments: Following the June 4 2020 recommendations of J. Anderson (2020) "CURRENT CTE-MITIGATION RECOMMENDATIONS", we aim for a minimum background level of 20 e-/pix in each WFC3/UVIS F275W exposure. Taking into account the raised natural background of this pseudo-CVZ visit, the WFC3/UVIS ETC shows that this requirement becomes satisfied for FLASH=11. The APT Phase-II diagnostics seem to still test the older (now superseded) recommendation of a minimum of only 12 e-/pix, and therefore result in a warning that the specified postflash may be too high.</i></p>									

Proposal 16793 - treasurehunt-epochA8of13 (01) - TREASUREHUNT: Hubble's UV-Visible treasury imaging of the JWST NEP Time...

6	(1) JWST-NEP-TDF ACS/WFC, ACCUM, WFCENTER F606W	POS TARG 9.900,+ 345.100	Sequence 1-26 Non-Int in treasurehunt-epochA8of13 (01) Prime + Parallel Group 6-8 in Sequence 1-26 Non-Int in treasurehunt-epochA8of13 (01)	1140 Secs (1140 Secs) [==>]	[1]
<p>Comments: The specified POS_TARG values intentionally place the WFC3/UVIS and ACS/WFC instrument apertures off the coordinates of the target (i.e., the center of the JWST NEP Time-Domain Field) to their intended locations within an annulus surrounding the extant HST data.</p>					
7	(1) JWST-NEP-TDF ACS/WFC, ACCUM, WFCENTER F435W	POS TARG 9.900,+ 345.100	Sequence 1-26 Non-Int in treasurehunt-epochA8of13 (01) Prime + Parallel Group 6-8 in Sequence 1-26 Non-Int in treasurehunt-epochA8of13 (01)	1140 Secs (1140 Secs) [==>]	[1]
8	(WFC3UVI ANY S.im.1445613) WFC3/UVIS, ACCUM, UVIS F275W FLASH=11		Sequence 1-26 Non-Int in treasurehunt-epochA8of13 (01) Prime + Parallel Group 6-8 in Sequence 1-26 Non-Int in treasurehunt-epochA8of13 (01)	2504 Secs (2504 Secs) [==>]	[1]
<p>Comments: Following the June 4 2020 recommendations of J. Anderson (2020) "CURRENT CTE-MITIGATION RECOMMENDATIONS", we aim for a minimum background level of 20 e-/pix in each WFC3/UVIS F275W exposure. Taking into account the raised natural background of this pseudo-CVZ visit, the WFC3/UVIS ETC shows that this requirement becomes satisfied for FLASH=11. The APT Phase-II diagnostics seem to still test the older (now superseded) recommendation of a minimum of only 12 e-/pix, and therefore result in a warning that the specified postflash may be too high.</p>					
9	(1) JWST-NEP-TDF ACS/WFC, ACCUM, WFCENTER F435W	POS TARG 10.100,+ +344.900	Sequence 1-26 Non-Int in treasurehunt-epochA8of13 (01) Prime + Parallel Group 9-11 in Sequence 1-26 Non-Int in treasurehunt-epochA8of13 (01)	1245 Secs (1245 Secs) [==>]	[2]
<p>Comments: The specified POS_TARG values intentionally place the WFC3/UVIS and ACS/WFC instrument apertures off the coordinates of the target (i.e., the center of the JWST NEP Time-Domain Field) to their intended locations within an annulus surrounding the extant HST data.</p>					
10	(1) JWST-NEP-TDF ACS/WFC, ACCUM, WFCENTER F606W	POS TARG 10.100,+ +344.900	Sequence 1-26 Non-Int in treasurehunt-epochA8of13 (01) Prime + Parallel Group 9-11 in Sequence 1-26 Non-Int in treasurehunt-epochA8of13 (01)	1245 Secs (1245 Secs) [==>]	[2]
11	(WFC3UVI ANY S.im.1445613) WFC3/UVIS, ACCUM, UVIS F275W FLASH=10		Sequence 1-26 Non-Int in treasurehunt-epochA8of13 (01) Prime + Parallel Group 9-11 in Sequence 1-26 Non-Int in treasurehunt-epochA8of13 (01)	2714 Secs (2714 Secs) [==>]	[2]
<p>Comments: Following the June 4 2020 recommendations of J. Anderson (2020) "CURRENT CTE-MITIGATION RECOMMENDATIONS", we aim for a minimum background level of 20 e-/pix in each WFC3/UVIS F275W exposure. Taking into account the raised natural background of this pseudo-CVZ visit, the WFC3/UVIS ETC shows that this requirement becomes satisfied for FLASH=10. The APT Phase-II diagnostics seem to still test the older (now superseded) recommendation of a minimum of only 12 e-/pix, and therefore result in a warning that the specified postflash may be too high.</p>					

Proposal 16793 - treasurehunt-epochA8of13 (01) - TREASUREHUNT: Hubble's UV-Visible treasury imaging of the JWST NEP Time...

12	(1) JWST-NEP-TDF ACS/WFC, ACCUM, WFCENTER F606W	POS TARG 9.900,+ 344.900	Sequence 1-26 Non-Int in treasurehunt-epochA8of13 (01) Prime + Parallel Group 12-14 in Sequence 1-26 Non-Int in treasurehunt-epochA8of13 (01)	1253 Secs (1253 Secs) [==>]	[2]
<p><i>Comments: The specified POS_TARG values intentionally place the WFC3/UVIS and ACS/WFC instrument apertures off the coordinates of the target (i.e., the center of the JWST NEP Time-Domain Field) to their intended locations within an annulus surrounding the extant HST data.</i></p>					
13	(1) JWST-NEP-TDF ACS/WFC, ACCUM, WFCENTER F435W	POS TARG 9.900,+ 344.900	Sequence 1-26 Non-Int in treasurehunt-epochA8of13 (01) Prime + Parallel Group 12-14 in Sequence 1-26 Non-Int in treasurehunt-epochA8of13 (01)	1254 Secs (1254 Secs) [==>]	[2]
14	(WFC3UVI ANY S.im.1445613) WFC3/UVIS, ACCUM, UVIS F275W FLASH=10		Sequence 1-26 Non-Int in treasurehunt-epochA8of13 (01) Prime + Parallel Group 12-14 in Sequence 1-26 Non-Int in treasurehunt-epochA8of13 (01)	2731 Secs (2731 Secs) [==>]	[2]
<p><i>Comments: Following the June 4 2020 recommendations of J. Anderson (2020) "CURRENT CTE-MITIGATION RECOMMENDATIONS", we aim for a minimum background level of 20 e-/pix in each WFC3/UVIS F275W exposure. Taking into account the raised natural background of this pseudo-CVZ visit, the WFC3/UVIS ETC shows that this requirement becomes satisfied for FLASH=10. The APT Phase-II diagnostics seem to still test the older (now superseded) recommendation of a minimum of only 12 e-/pix, and therefore result in a warning that the specified postflash may be too high.</i></p>					
15	(1) JWST-NEP-TDF ACS/WFC, ACCUM, WFCENTER F435W	POS TARG 10.200,+ +345.200	Sequence 1-26 Non-Int in treasurehunt-epochA8of13 (01) Prime + Parallel Group 15-17 in Sequence 1-26 Non-Int in treasurehunt-epochA8of13 (01)	1245 Secs (1245 Secs) [==>]	[3]
<p><i>Comments: The specified POS_TARG values intentionally place the WFC3/UVIS and ACS/WFC instrument apertures off the coordinates of the target (i.e., the center of the JWST NEP Time-Domain Field) to their intended locations within an annulus surrounding the extant HST data.</i></p>					
16	(1) JWST-NEP-TDF ACS/WFC, ACCUM, WFCENTER F606W	POS TARG 10.200,+ +345.200	Sequence 1-26 Non-Int in treasurehunt-epochA8of13 (01) Prime + Parallel Group 15-17 in Sequence 1-26 Non-Int in treasurehunt-epochA8of13 (01)	1245 Secs (1245 Secs) [==>]	[3]
17	(WFC3UVI ANY S.im.1445613) WFC3/UVIS, ACCUM, UVIS F275W FLASH=10		Sequence 1-26 Non-Int in treasurehunt-epochA8of13 (01) Prime + Parallel Group 15-17 in Sequence 1-26 Non-Int in treasurehunt-epochA8of13 (01)	2714 Secs (2714 Secs) [==>]	[3]
<p><i>Comments: Following the June 4 2020 recommendations of J. Anderson (2020) "CURRENT CTE-MITIGATION RECOMMENDATIONS", we aim for a minimum background level of 20 e-/pix in each WFC3/UVIS F275W exposure. Taking into account the raised natural background of this pseudo-CVZ visit, the WFC3/UVIS ETC shows that this requirement becomes satisfied for FLASH=10. The APT Phase-II diagnostics seem to still test the older (now superseded) recommendation of a minimum of only 12 e-/pix, and therefore result in a warning that the specified postflash may be too high.</i></p>					

Proposal 16793 - treasurehunt-epochA8of13 (01) - TREASUREHUNT: Hubble's UV-Visible treasury imaging of the JWST NEP Time...

18	(1) JWST-NEP-TDF ACS/WFC, ACCUM, WFCENTER F606W	POS TARG 10.000, +345.200	Sequence 1-26 Non-Int in treasurehunt-epochA8of13 (01) Prime + Parallel Group 18-20 in Sequence 1-26 Non-Int in treasurehunt-epochA8of13 (01)	1253 Secs (1253 Secs) [==>]	[3]
<p><i>Comments: The specified POS_TARG values intentionally place the WFC3/UVIS and ACS/WFC instrument apertures off the coordinates of the target (i.e., the center of the JWST NEP Time-Domain Field) to their intended locations within an annulus surrounding the extant HST data.</i></p>					
19	(1) JWST-NEP-TDF ACS/WFC, ACCUM, WFCENTER F435W	POS TARG 10.000, +345.200	Sequence 1-26 Non-Int in treasurehunt-epochA8of13 (01) Prime + Parallel Group 18-20 in Sequence 1-26 Non-Int in treasurehunt-epochA8of13 (01)	1254 Secs (1254 Secs) [==>]	[3]
20	(WFC3UVI ANY S.im.1445613) WFC3/UVIS, ACCUM, UVIS F275W FLASH=10		Sequence 1-26 Non-Int in treasurehunt-epochA8of13 (01) Prime + Parallel Group 18-20 in Sequence 1-26 Non-Int in treasurehunt-epochA8of13 (01)	2731 Secs (2731 Secs) [==>]	[3]
<p><i>Comments: Following the June 4 2020 recommendations of J. Anderson (2020) "CURRENT CTE-MITIGATION RECOMMENDATIONS", we aim for a minimum background level of 20 e-/pix in each WFC3/UVIS F275W exposure. Taking into account the raised natural background of this pseudo-CVZ visit, the WFC3/UVIS ETC shows that this requirement becomes satisfied for FLASH=10. The APT Phase-II diagnostics seem to still test the older (now superseded) recommendation of a minimum of only 12 e-/pix, and therefore result in a warning that the specified postflash may be too high.</i></p>					
21	(1) JWST-NEP-TDF ACS/WFC, ACCUM, WFCENTER F435W	POS TARG 10.200, +345.000	Sequence 1-26 Non-Int in treasurehunt-epochA8of13 (01) Prime + Parallel Group 21-23 in Sequence 1-26 Non-Int in treasurehunt-epochA8of13 (01)	994 Secs (994 Secs) [==>]	[4]
<p><i>Comments: The specified POS_TARG values intentionally place the WFC3/UVIS and ACS/WFC instrument apertures off the coordinates of the target (i.e., the center of the JWST NEP Time-Domain Field) to their intended locations within an annulus surrounding the extant HST data.</i></p>					
22	(1) JWST-NEP-TDF ACS/WFC, ACCUM, WFCENTER F606W	POS TARG 10.200, +345.000	Sequence 1-26 Non-Int in treasurehunt-epochA8of13 (01) Prime + Parallel Group 21-23 in Sequence 1-26 Non-Int in treasurehunt-epochA8of13 (01)	994 Secs (994 Secs) [==>]	[4]
23	(WFC3UVI ANY S.im.1445644) WFC3/UVIS, ACCUM, UVIS F275W FLASH=12		Sequence 1-26 Non-Int in treasurehunt-epochA8of13 (01) Prime + Parallel Group 21-23 in Sequence 1-26 Non-Int in treasurehunt-epochA8of13 (01)	2212 Secs (2212 Secs) [==>]	[4]
<p><i>Comments: Following the June 4 2020 recommendations of J. Anderson (2020) "CURRENT CTE-MITIGATION RECOMMENDATIONS", we aim for a minimum background level of 20 e-/pix in each WFC3/UVIS F275W exposure. Taking into account the raised natural background of this pseudo-CVZ visit, the WFC3/UVIS ETC shows that this requirement becomes satisfied for FLASH=12. The APT Phase-II diagnostics seem to still test the older (now superseded) recommendation of a minimum of only 12 e-/pix, and therefore result in a warning that the specified postflash may be too high.</i></p>					

Proposal 16793 - treasurehunt-epochA8of13 (01) - TREASUREHUNT: Hubble's UV-Visible treasury imaging of the JWST NEP Time...

24	(1) JWST-NEP-TDF ACS/WFC, ACCUM, WFCENTER F606W	POS TARG 10.000, +345.000	Sequence 1-26 Non-Int in treasurehunt-epochA8of13 (01) Prime + Parallel Group 24-26 in Sequence 1-26 Non-Int in treasurehunt-epochA8of13 (01)	997 Secs (997 Secs)	[==>]	[4]
<p><i>Comments: The specified POS_TARG values intentionally place the WFC3/UVIS and ACS/WFC instrument apertures off the coordinates of the target (i.e., the center of the JWST NEP Time-Domain Field) to their intended locations within an annulus surrounding the extant HST data.</i></p>						
25	(1) JWST-NEP-TDF ACS/WFC, ACCUM, WFCENTER F435W	POS TARG 10.000, +345.000	Sequence 1-26 Non-Int in treasurehunt-epochA8of13 (01) Prime + Parallel Group 24-26 in Sequence 1-26 Non-Int in treasurehunt-epochA8of13 (01)	997 Secs (997 Secs)	[==>]	[4]
26	(WFC3UVI ANY S.im.1445644) WFC3/UVIS, ACCUM, UVIS F275W FLASH=12		Sequence 1-26 Non-Int in treasurehunt-epochA8of13 (01) Prime + Parallel Group 24-26 in Sequence 1-26 Non-Int in treasurehunt-epochA8of13 (01)	2198 Secs (2198 Secs)	[==>]	[4]
<p><i>Comments: Following the June 4 2020 recommendations of J. Anderson (2020) "CURRENT CTE-MITIGATION RECOMMENDATIONS", we aim for a minimum background level of 20 e-/pix in each WFC3/UVIS F275W exposure. Taking into account the raised natural background of this pseudo-CVZ visit, the WFC3/UVIS ETC shows that this requirement becomes satisfied for FLASH=12. The APT Phase-II diagnostics seem to still test the older (now superseded) recommendation of a minimum of only 12 e-/pix, and therefore result in a warning that the specified postflash may be too high.</i></p>						

Proposal 16793 - treasurehunt-epoch09of13 (02) - TREASUREHUNT: Hubble's UV-Visible treasury imaging of the JWST NEP Time...

#	Label (ETC Run)	Target	Config,Mode,Aperture	Spectral Els.	Opt. Params.	Special Reqs.	Groups	Exp. Time (Total)/[Actual Dur.]	Orbit
1		(1) JWST-NEP-TDF	ACS/WFC, ACCUM, WFCENTER	F435W		POS TARG 44.9,+3 75.100	Sequence 1-26 Non-Int in treasurehunt-epoch09of13 (02) Prime + Parallel Group 1-2 in Sequence 1-26 Non-Int in treasurehunt-epoch09of13 (02)	1040 Secs (1040 Secs) [==>]	[1]
<p><i>Comments: The specified POS_TARG values intentionally place the WFC3/UVIS and ACS/WFC instrument apertures off the coordinates of the target (i.e., the center of the JWST NEP Time-Domain Field) to their intended locations within an annulus surrounding the extant HST data.</i></p>									
2	(WFC3UVIS.im.1445613)	ANY	WFC3/UVIS, ACCUM, UVIS	F275W	FLASH=11		Sequence 1-26 Non-Int in treasurehunt-epoch09of13 (02) Prime + Parallel Group 1-2 in Sequence 1-26 Non-Int in treasurehunt-epoch09of13 (02)	1090 Secs (1090 Secs) [==>]	[1]
<p><i>Comments: Following the June 4 2020 recommendations of J. Anderson (2020) "CURRENT CTE-MITIGATION RECOMMENDATIONS", we aim for a minimum background level of 20 e-/pix in each WFC3/UVIS F275W exposure. Taking into account the raised natural background of this pseudo-CVZ visit, the WFC3/UVIS ETC shows that this requirement becomes satisfied for FLASH=11. The APT Phase-II diagnostics seem to still test the older (now superseded) recommendation of a minimum of only 12 e-/pix, and therefore result in a warning that the specified postflash may be too high.</i></p>									
3		(1) JWST-NEP-TDF	ACS/WFC, ACCUM, WFCENTER	F435W		POS TARG 44.9,+3 75.100	Sequence 1-26 Non-Int in treasurehunt-epoch09of13 (02) Prime + Parallel Group 3-5 in Sequence 1-26 Non-Int in treasurehunt-epoch09of13 (02)	1136 Secs (1136 Secs) [==>]	[1]
<p><i>Comments: The specified POS_TARG values intentionally place the WFC3/UVIS and ACS/WFC instrument apertures off the coordinates of the target (i.e., the center of the JWST NEP Time-Domain Field) to their intended locations within an annulus surrounding the extant HST data.</i></p>									
4		(1) JWST-NEP-TDF	ACS/WFC, ACCUM, WFCENTER	F606W		POS TARG 44.9,+3 75.100	Sequence 1-26 Non-Int in treasurehunt-epoch09of13 (02) Prime + Parallel Group 3-5 in Sequence 1-26 Non-Int in treasurehunt-epoch09of13 (02)	1136 Secs (1136 Secs) [==>]	[1]
5	(WFC3UVIS.im.1445613)	ANY	WFC3/UVIS, ACCUM, UVIS	F275W	FLASH=11		Sequence 1-26 Non-Int in treasurehunt-epoch09of13 (02) Prime + Parallel Group 3-5 in Sequence 1-26 Non-Int in treasurehunt-epoch09of13 (02)	2495 Secs (2495 Secs) [==>]	[1]
<p><i>Comments: Following the June 4 2020 recommendations of J. Anderson (2020) "CURRENT CTE-MITIGATION RECOMMENDATIONS", we aim for a minimum background level of 20 e-/pix in each WFC3/UVIS F275W exposure. Taking into account the raised natural background of this pseudo-CVZ visit, the WFC3/UVIS ETC shows that this requirement becomes satisfied for FLASH=11. The APT Phase-II diagnostics seem to still test the older (now superseded) recommendation of a minimum of only 12 e-/pix, and therefore result in a warning that the specified postflash may be too high.</i></p>									

Proposal 16793 - treasurehunt-epoch09of13 (02) - TREASUREHUNT: Hubble's UV-Visible treasury imaging of the JWST NEP Time...

6	(1) JWST-NEP-TDF ACS/WFC, ACCUM, WFCENTER F606W	POS TARG +45.100 ,+375.100	Sequence 1-26 Non-Int in treasurehunt-epoch09of13 (02) Prime + Parallel Group 6-8 in Sequence 1-26 Non-Int in treasurehunt-epoch09of13 (02)	1140 Secs (1140 Secs) [==>]	[1]
<p>Comments: The specified POS_TARG values intentionally place the WFC3/UVIS and ACS/WFC instrument apertures off the coordinates of the target (i.e., the center of the JWST NEP Time-Domain Field) to their intended locations within an annulus surrounding the extant HST data.</p>					
7	(1) JWST-NEP-TDF ACS/WFC, ACCUM, WFCENTER F435W	POS TARG +45.100 ,+375.100	Sequence 1-26 Non-Int in treasurehunt-epoch09of13 (02) Prime + Parallel Group 6-8 in Sequence 1-26 Non-Int in treasurehunt-epoch09of13 (02)	1140 Secs (1140 Secs) [==>]	[1]
8	(WFC3UVI ANY S.im.1445613) WFC3/UVIS, ACCUM, UVIS F275W FLASH=11		Sequence 1-26 Non-Int in treasurehunt-epoch09of13 (02) Prime + Parallel Group 6-8 in Sequence 1-26 Non-Int in treasurehunt-epoch09of13 (02)	2504 Secs (2504 Secs) [==>]	[1]
<p>Comments: Following the June 4 2020 recommendations of J. Anderson (2020) "CURRENT CTE-MITIGATION RECOMMENDATIONS", we aim for a minimum background level of 20 e-/pix in each WFC3/UVIS F275W exposure. Taking into account the raised natural background of this pseudo-CVZ visit, the WFC3/UVIS ETC shows that this requirement becomes satisfied for FLASH=11. The APT Phase-II diagnostics seem to still test the older (now superseded) recommendation of a minimum of only 12 e-/pix, and therefore result in a warning that the specified postflash may be too high.</p>					
9	(1) JWST-NEP-TDF ACS/WFC, ACCUM, WFCENTER F435W	POS TARG 44.9,+3 74.900	Sequence 1-26 Non-Int in treasurehunt-epoch09of13 (02) Prime + Parallel Group 9-11 in Sequence 1-26 Non-Int in treasurehunt-epoch09of13 (02)	1245 Secs (1245 Secs) [==>]	[2]
<p>Comments: The specified POS_TARG values intentionally place the WFC3/UVIS and ACS/WFC instrument apertures off the coordinates of the target (i.e., the center of the JWST NEP Time-Domain Field) to their intended locations within an annulus surrounding the extant HST data.</p>					
10	(1) JWST-NEP-TDF ACS/WFC, ACCUM, WFCENTER F606W	POS TARG 44.9,+3 74.900	Sequence 1-26 Non-Int in treasurehunt-epoch09of13 (02) Prime + Parallel Group 9-11 in Sequence 1-26 Non-Int in treasurehunt-epoch09of13 (02)	1245 Secs (1245 Secs) [==>]	[2]
11	(WFC3UVI ANY S.im.1445613) WFC3/UVIS, ACCUM, UVIS F275W FLASH=10		Sequence 1-26 Non-Int in treasurehunt-epoch09of13 (02) Prime + Parallel Group 9-11 in Sequence 1-26 Non-Int in treasurehunt-epoch09of13 (02)	2714 Secs (2714 Secs) [==>]	[2]
<p>Comments: Following the June 4 2020 recommendations of J. Anderson (2020) "CURRENT CTE-MITIGATION RECOMMENDATIONS", we aim for a minimum background level of 20 e-/pix in each WFC3/UVIS F275W exposure. Taking into account the raised natural background of this pseudo-CVZ visit, the WFC3/UVIS ETC shows that this requirement becomes satisfied for FLASH=10. The APT Phase-II diagnostics seem to still test the older (now superseded) recommendation of a minimum of only 12 e-/pix, and therefore result in a warning that the specified postflash may be too high.</p>					

Proposal 16793 - treasurehunt-epoch09of13 (02) - TREASUREHUNT: Hubble's UV-Visible treasury imaging of the JWST NEP Time-...

12	(1) JWST-NEP-TDF ACS/WFC, ACCUM, WFCENTER F606W	POS TARG +45.100 ,+374.900	Sequence 1-26 Non-Int in treasurehunt-epoch09of13 (02) Prime + Parallel Group 12-14 in Sequence 1-26 Non-Int in treasurehunt-epoch09of13 (02)	1253 Secs (1253 Secs) [==>]	[2]
<p><i>Comments: The specified POS_TARG values intentionally place the WFC3/UVIS and ACS/WFC instrument apertures off the coordinates of the target (i.e., the center of the JWST NEP Time-Domain Field) to their intended locations within an annulus surrounding the extant HST data.</i></p>					
13	(1) JWST-NEP-TDF ACS/WFC, ACCUM, WFCENTER F435W	POS TARG +45.100 ,+374.900	Sequence 1-26 Non-Int in treasurehunt-epoch09of13 (02) Prime + Parallel Group 12-14 in Sequence 1-26 Non-Int in treasurehunt-epoch09of13 (02)	1254 Secs (1254 Secs) [==>]	[2]
14	(WFC3UVI ANY S.im.1445613) WFC3/UVIS, ACCUM, UVIS F275W FLASH=10		Sequence 1-26 Non-Int in treasurehunt-epoch09of13 (02) Prime + Parallel Group 12-14 in Sequence 1-26 Non-Int in treasurehunt-epoch09of13 (02)	2731 Secs (2731 Secs) [==>]	[2]
<p><i>Comments: Following the June 4 2020 recommendations of J. Anderson (2020) "CURRENT CTE-MITIGATION RECOMMENDATIONS", we aim for a minimum background level of 20 e-/pix in each WFC3/UVIS F275W exposure. Taking into account the raised natural background of this pseudo-CVZ visit, the WFC3/UVIS ETC shows that this requirement becomes satisfied for FLASH=10. The APT Phase-II diagnostics seem to still test the older (now superseded) recommendation of a minimum of only 12 e-/pix, and therefore result in a warning that the specified postflash may be too high.</i></p>					
15	(1) JWST-NEP-TDF ACS/WFC, ACCUM, WFCENTER F435W	POS TARG 44.8,+3 75.200	Sequence 1-26 Non-Int in treasurehunt-epoch09of13 (02) Prime + Parallel Group 15-17 in Sequence 1-26 Non-Int in treasurehunt-epoch09of13 (02)	1245 Secs (1245 Secs) [==>]	[3]
<p><i>Comments: The specified POS_TARG values intentionally place the WFC3/UVIS and ACS/WFC instrument apertures off the coordinates of the target (i.e., the center of the JWST NEP Time-Domain Field) to their intended locations within an annulus surrounding the extant HST data.</i></p>					
16	(1) JWST-NEP-TDF ACS/WFC, ACCUM, WFCENTER F606W	POS TARG 44.8,+3 75.200	Sequence 1-26 Non-Int in treasurehunt-epoch09of13 (02) Prime + Parallel Group 15-17 in Sequence 1-26 Non-Int in treasurehunt-epoch09of13 (02)	1245 Secs (1245 Secs) [==>]	[3]
17	(WFC3UVI ANY S.im.1445613) WFC3/UVIS, ACCUM, UVIS F275W FLASH=10		Sequence 1-26 Non-Int in treasurehunt-epoch09of13 (02) Prime + Parallel Group 15-17 in Sequence 1-26 Non-Int in treasurehunt-epoch09of13 (02)	2714 Secs (2714 Secs) [==>]	[3]
<p><i>Comments: Following the June 4 2020 recommendations of J. Anderson (2020) "CURRENT CTE-MITIGATION RECOMMENDATIONS", we aim for a minimum background level of 20 e-/pix in each WFC3/UVIS F275W exposure. Taking into account the raised natural background of this pseudo-CVZ visit, the WFC3/UVIS ETC shows that this requirement becomes satisfied for FLASH=10. The APT Phase-II diagnostics seem to still test the older (now superseded) recommendation of a minimum of only 12 e-/pix, and therefore result in a warning that the specified postflash may be too high.</i></p>					

Proposal 16793 - treasurehunt-epoch09of13 (02) - TREASUREHUNT: Hubble's UV-Visible treasury imaging of the JWST NEP Time...

18	(1) JWST-NEP-TDF ACS/WFC, ACCUM, WFCENTER F606W	POS TARG +45.000 ,+375.200	Sequence 1-26 Non-Int in treasurehunt-epoch09of13 (02) Prime + Parallel Group 18-20 in Sequence 1-26 Non-Int in treasurehunt-epoch09of13 (02)	1253 Secs (1253 Secs) [==>]	[3]
<p>Comments: The specified POS_TARG values intentionally place the WFC3/UVIS and ACS/WFC instrument apertures off the coordinates of the target (i.e., the center of the JWST NEP Time-Domain Field) to their intended locations within an annulus surrounding the extant HST data.</p>					
19	(1) JWST-NEP-TDF ACS/WFC, ACCUM, WFCENTER F435W	POS TARG +45.000 ,+375.200	Sequence 1-26 Non-Int in treasurehunt-epoch09of13 (02) Prime + Parallel Group 18-20 in Sequence 1-26 Non-Int in treasurehunt-epoch09of13 (02)	1254 Secs (1254 Secs) [==>]	[3]
20	(WFC3UVI ANY S.im.1445613) WFC3/UVIS, ACCUM, UVIS F275W FLASH=10		Sequence 1-26 Non-Int in treasurehunt-epoch09of13 (02) Prime + Parallel Group 18-20 in Sequence 1-26 Non-Int in treasurehunt-epoch09of13 (02)	2731 Secs (2731 Secs) [==>]	[3]
<p>Comments: Following the June 4 2020 recommendations of J. Anderson (2020) "CURRENT CTE-MITIGATION RECOMMENDATIONS", we aim for a minimum background level of 20 e-/pix in each WFC3/UVIS F275W exposure. Taking into account the raised natural background of this pseudo-CVZ visit, the WFC3/UVIS ETC shows that this requirement becomes satisfied for FLASH=10. The APT Phase-II diagnostics seem to still test the older (now superseded) recommendation of a minimum of only 12 e-/pix, and therefore result in a warning that the specified postflash may be too high.</p>					
21	(1) JWST-NEP-TDF ACS/WFC, ACCUM, WFCENTER F435W	POS TARG 44.8,+375.000	Sequence 1-26 Non-Int in treasurehunt-epoch09of13 (02) Prime + Parallel Group 21-23 in Sequence 1-26 Non-Int in treasurehunt-epoch09of13 (02)	994 Secs (994 Secs) [==>]	[4]
<p>Comments: The specified POS_TARG values intentionally place the WFC3/UVIS and ACS/WFC instrument apertures off the coordinates of the target (i.e., the center of the JWST NEP Time-Domain Field) to their intended locations within an annulus surrounding the extant HST data.</p>					
22	(1) JWST-NEP-TDF ACS/WFC, ACCUM, WFCENTER F606W	POS TARG 44.8,+375.000	Sequence 1-26 Non-Int in treasurehunt-epoch09of13 (02) Prime + Parallel Group 21-23 in Sequence 1-26 Non-Int in treasurehunt-epoch09of13 (02)	994 Secs (994 Secs) [==>]	[4]
23	(WFC3UVI ANY S.im.1445644) WFC3/UVIS, ACCUM, UVIS F275W FLASH=12		Sequence 1-26 Non-Int in treasurehunt-epoch09of13 (02) Prime + Parallel Group 21-23 in Sequence 1-26 Non-Int in treasurehunt-epoch09of13 (02)	2212 Secs (2212 Secs) [==>]	[4]
<p>Comments: Following the June 4 2020 recommendations of J. Anderson (2020) "CURRENT CTE-MITIGATION RECOMMENDATIONS", we aim for a minimum background level of 20 e-/pix in each WFC3/UVIS F275W exposure. Taking into account the raised natural background of this pseudo-CVZ visit, the WFC3/UVIS ETC shows that this requirement becomes satisfied for FLASH=12. The APT Phase-II diagnostics seem to still test the older (now superseded) recommendation of a minimum of only 12 e-/pix, and therefore result in a warning that the specified postflash may be too high.</p>					

Proposal 16793 - treasurehunt-epoch09of13 (02) - TREASUREHUNT: Hubble's UV-Visible treasury imaging of the JWST NEP Time-...

24	(1) JWST-NEP-TDF ACS/WFC, ACCUM, WFCENTER F606W	POS TARG +45.000 ,+375.000	Sequence 1-26 Non-Int in treasurehunt-epoch09of13 (02) Prime + Parallel Group 24-26 in Sequence 1-26 Non-Int in treasurehunt-epoch09of13 (02)	997 Secs (997 Secs)	[==>]	[4]		
<p><i>Comments: The specified POS_TARG values intentionally place the WFC3/UVIS and ACS/WFC instrument apertures off the coordinates of the target (i.e., the center of the JWST NEP Time-Domain Field) to their intended locations within an annulus surrounding the extant HST data.</i></p>								
25	(1) JWST-NEP-TDF ACS/WFC, ACCUM, WFCENTER F435W	POS TARG +45.000 ,+375.000	Sequence 1-26 Non-Int in treasurehunt-epoch09of13 (02) Prime + Parallel Group 24-26 in Sequence 1-26 Non-Int in treasurehunt-epoch09of13 (02)	997 Secs (997 Secs)	[==>]	[4]		
26	(WFC3UVI ANY S.im.144564 4)	WFC3/UVIS, ACCUM, UVIS	F275W	FLASH=12	Sequence 1-26 Non-Int in treasurehunt-epoch09of13 (02) Prime + Parallel Group 24-26 in Sequence 1-26 Non-Int in treasurehunt-epoch09of13 (02)	2198 Secs (2198 Secs)	[==>]	[4]
<p><i>Comments: Following the June 4 2020 recommendations of J. Anderson (2020) "CURRENT CTE-MITIGATION RECOMMENDATIONS", we aim for a minimum background level of 20 e-/pix in each WFC3/UVIS F275W exposure. Taking into account the raised natural background of this pseudo-CVZ visit, the WFC3/UVIS ETC shows that this requirement becomes satisfied for FLASH=12. The APT Phase-II diagnostics seem to still test the older (now superseded) recommendation of a minimum of only 12 e-/pix, and therefore result in a warning that the specified postflash may be too high.</i></p>								

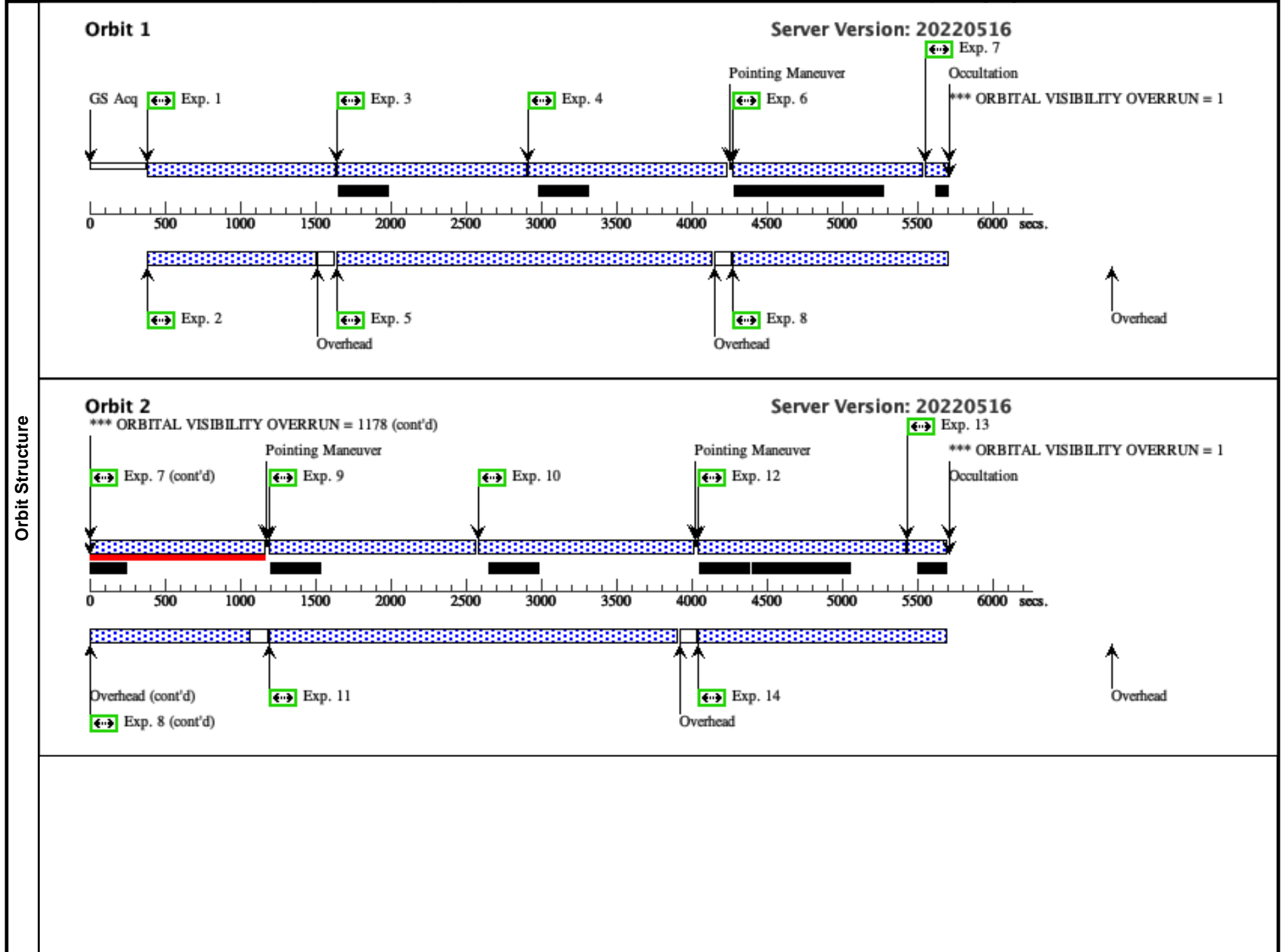

Orbit 3

Server Version: 20220516

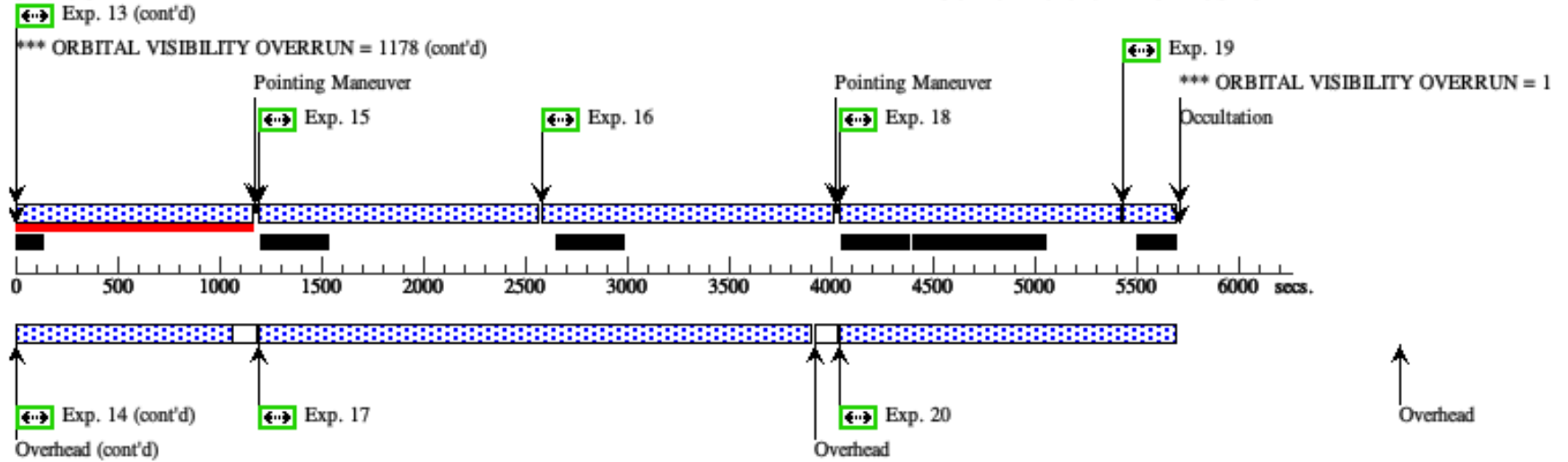

Orbit 4

Server Version: 20220516

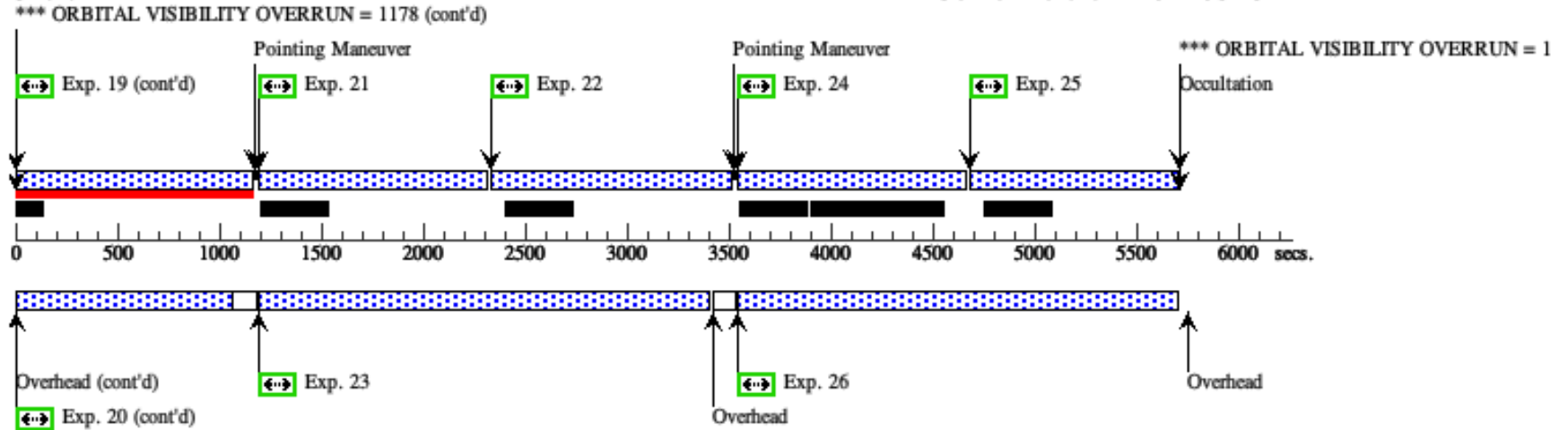

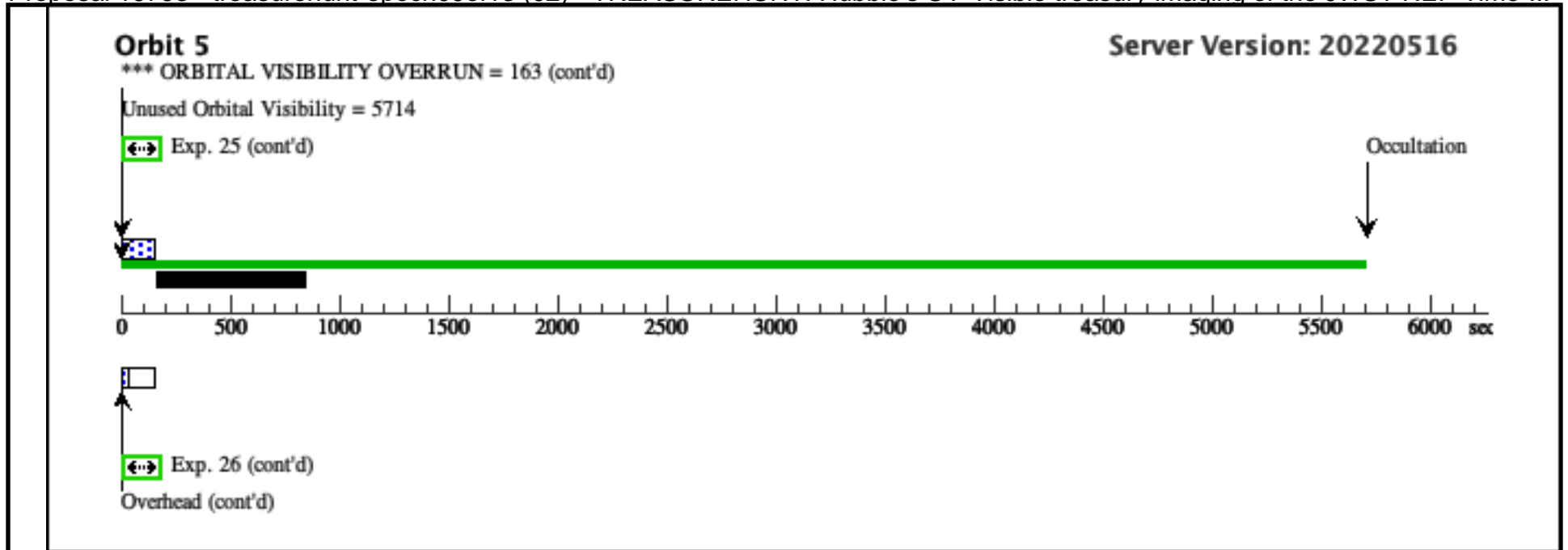

Proposal 16793 - treasurehunt-epoch10of13 (03) - TREASUREHUNT: Hubble's UV-Visible treasury imaging of the JWST NEP Time...

#	Label (ETC Run)	Target	Config,Mode,Aperture	Spectral Els.	Opt. Params.	Special Reqs.	Groups	Exp. Time (Total)/[Actual Dur.]	Orbit
1		(1) JWST-NEP-TDF	ACS/WFC, ACCUM, WFCENTER	F435W		POS TARG 44.9,+3 65.100	Sequence 1-26 Non-Int in treasurehunt-epoch10of13 (03) Prime + Parallel Group 1-2 in Sequence 1-26 Non-Int in treasurehunt-epoch10of13 (03)	860 Secs (860 Secs) [==>]	[1]
<p>Comments: The specified POS_TARG values intentionally place the WFC3/UVIS and ACS/WFC instrument apertures off the coordinates of the target (i.e., the center of the JWST NEP Time-Domain Field) to their intended locations within an annulus surrounding the extant HST data.</p>									
2	(WFC3UVIS.im.1445613)	ANY	WFC3/UVIS, ACCUM, UVIS	F275W	FLASH=16		Sequence 1-26 Non-Int in treasurehunt-epoch10of13 (03) Prime + Parallel Group 1-2 in Sequence 1-26 Non-Int in treasurehunt-epoch10of13 (03)	910 Secs (910 Secs) [==>]	[1]
<p>Comments: Following the June 4 2020 recommendations of J. Anderson (2020) "CURRENT CTE-MITIGATION RECOMMENDATIONS", we aim for a minimum background level of 20 e-/pix in each WFC3/UVIS F275W exposure. Taking into account the raised natural background of this pseudo-CVZ visit, the WFC3/UVIS ETC shows that this requirement becomes satisfied for FLASH=11. The APT Phase-II diagnostics seem to still test the older (now superseded) recommendation of a minimum of only 12 e-/pix, and therefore result in a warning that the specified postflash may be too high.</p>									
3		(1) JWST-NEP-TDF	ACS/WFC, ACCUM, WFCENTER	F435W		POS TARG 44.9,+3 65.100	Sequence 1-26 Non-Int in treasurehunt-epoch10of13 (03) Prime + Parallel Group 3-5 in Sequence 1-26 Non-Int in treasurehunt-epoch10of13 (03)	1136 Secs (1136 Secs) [==>]	[1]
<p>Comments: The specified POS_TARG values intentionally place the WFC3/UVIS and ACS/WFC instrument apertures off the coordinates of the target (i.e., the center of the JWST NEP Time-Domain Field) to their intended locations within an annulus surrounding the extant HST data.</p>									
4		(1) JWST-NEP-TDF	ACS/WFC, ACCUM, WFCENTER	F606W		POS TARG 44.9,+3 65.100	Sequence 1-26 Non-Int in treasurehunt-epoch10of13 (03) Prime + Parallel Group 3-5 in Sequence 1-26 Non-Int in treasurehunt-epoch10of13 (03)	1136 Secs (1136 Secs) [==>]	[1]
5	(WFC3UVIS.im.1445613)	ANY	WFC3/UVIS, ACCUM, UVIS	F275W	FLASH=11		Sequence 1-26 Non-Int in treasurehunt-epoch10of13 (03) Prime + Parallel Group 3-5 in Sequence 1-26 Non-Int in treasurehunt-epoch10of13 (03)	2495 Secs (2495 Secs) [==>]	[1]
<p>Comments: Following the June 4 2020 recommendations of J. Anderson (2020) "CURRENT CTE-MITIGATION RECOMMENDATIONS", we aim for a minimum background level of 20 e-/pix in each WFC3/UVIS F275W exposure. Taking into account the raised natural background of this pseudo-CVZ visit, the WFC3/UVIS ETC shows that this requirement becomes satisfied for FLASH=11. The APT Phase-II diagnostics seem to still test the older (now superseded) recommendation of a minimum of only 12 e-/pix, and therefore result in a warning that the specified postflash may be too high.</p>									

Proposal 16793 - treasurehunt-epoch10of13 (03) - TREASUREHUNT: Hubble's UV-Visible treasury imaging of the JWST NEP Time...

6	(1) JWST-NEP-TDF ACS/WFC, ACCUM, WFCENTER F606W	POS TARG +45.100 ,+365.100	Sequence 1-26 Non-Int in treasurehunt-epoch10of13 (03) Prime + Parallel Group 6-8 in Sequence 1-26 Non-Int in treasurehunt-epoch10of13 (03)	1140 Secs (1140 Secs) [==>]	[1]
<p><i>Comments: The specified POS_TARG values intentionally place the WFC3/UVIS and ACS/WFC instrument apertures off the coordinates of the target (i.e., the center of the JWST NEP Time-Domain Field) to their intended locations within an annulus surrounding the extant HST data.</i></p>					
7	(1) JWST-NEP-TDF ACS/WFC, ACCUM, WFCENTER F435W	POS TARG +45.100 ,+365.100	Sequence 1-26 Non-Int in treasurehunt-epoch10of13 (03) Prime + Parallel Group 6-8 in Sequence 1-26 Non-Int in treasurehunt-epoch10of13 (03)	1140 Secs (1140 Secs) [==>]	[1]
8	(WFC3UVI ANY S.im.1445613) WFC3/UVIS, ACCUM, UVIS F275W FLASH=11		Sequence 1-26 Non-Int in treasurehunt-epoch10of13 (03) Prime + Parallel Group 6-8 in Sequence 1-26 Non-Int in treasurehunt-epoch10of13 (03)	2504 Secs (2504 Secs) [==>]	[1]
<p><i>Comments: Following the June 4 2020 recommendations of J. Anderson (2020) "CURRENT CTE-MITIGATION RECOMMENDATIONS", we aim for a minimum background level of 20 e-/pix in each WFC3/UVIS F275W exposure. Taking into account the raised natural background of this pseudo-CVZ visit, the WFC3/UVIS ETC shows that this requirement becomes satisfied for FLASH=11. The APT Phase-II diagnostics seem to still test the older (now superseded) recommendation of a minimum of only 12 e-/pix, and therefore result in a warning that the specified postflash may be too high.</i></p>					
9	(1) JWST-NEP-TDF ACS/WFC, ACCUM, WFCENTER F435W	POS TARG 44.9,+3 64.900	Sequence 1-26 Non-Int in treasurehunt-epoch10of13 (03) Prime + Parallel Group 9-11 in Sequence 1-26 Non-Int in treasurehunt-epoch10of13 (03)	1245 Secs (1245 Secs) [==>]	[2]
<p><i>Comments: The specified POS_TARG values intentionally place the WFC3/UVIS and ACS/WFC instrument apertures off the coordinates of the target (i.e., the center of the JWST NEP Time-Domain Field) to their intended locations within an annulus surrounding the extant HST data.</i></p>					
10	(1) JWST-NEP-TDF ACS/WFC, ACCUM, WFCENTER F606W	POS TARG 44.9,+3 64.900	Sequence 1-26 Non-Int in treasurehunt-epoch10of13 (03) Prime + Parallel Group 9-11 in Sequence 1-26 Non-Int in treasurehunt-epoch10of13 (03)	1245 Secs (1245 Secs) [==>]	[2]
11	(WFC3UVI ANY S.im.1445613) WFC3/UVIS, ACCUM, UVIS F275W FLASH=10		Sequence 1-26 Non-Int in treasurehunt-epoch10of13 (03) Prime + Parallel Group 9-11 in Sequence 1-26 Non-Int in treasurehunt-epoch10of13 (03)	2714 Secs (2714 Secs) [==>]	[2]
<p><i>Comments: Following the June 4 2020 recommendations of J. Anderson (2020) "CURRENT CTE-MITIGATION RECOMMENDATIONS", we aim for a minimum background level of 20 e-/pix in each WFC3/UVIS F275W exposure. Taking into account the raised natural background of this pseudo-CVZ visit, the WFC3/UVIS ETC shows that this requirement becomes satisfied for FLASH=10. The APT Phase-II diagnostics seem to still test the older (now superseded) recommendation of a minimum of only 12 e-/pix, and therefore result in a warning that the specified postflash may be too high.</i></p>					

Proposal 16793 - treasurehunt-epoch10of13 (03) - TREASUREHUNT: Hubble's UV-Visible treasury imaging of the JWST NEP Time-...

12	(1) JWST-NEP-TDF ACS/WFC, ACCUM, WFCENTER F606W	POS TARG +45.100 ,+364.900	Sequence 1-26 Non-Int in treasurehunt-epoch10of13 (03) Prime + Parallel Group 12-14 in Sequence 1-26 Non-Int in treasurehunt-epoch10of13 (03)	1253 Secs (1253 Secs) [==>]	[2]
<i>Comments: The specified POS_TARG values intentionally place the WFC3/UVIS and ACS/WFC instrument apertures off the coordinates of the target (i.e., the center of the JWST NEP Time-Domain Field) to their intended locations within an annulus surrounding the extant HST data.</i>					
13	(1) JWST-NEP-TDF ACS/WFC, ACCUM, WFCENTER F435W	POS TARG +45.100 ,+364.900	Sequence 1-26 Non-Int in treasurehunt-epoch10of13 (03) Prime + Parallel Group 12-14 in Sequence 1-26 Non-Int in treasurehunt-epoch10of13 (03)	1254 Secs (1254 Secs) [==>]	[2]
14	(WFC3UVI ANY S.im.1445613) WFC3/UVIS, ACCUM, UVIS F275W FLASH=10		Sequence 1-26 Non-Int in treasurehunt-epoch10of13 (03) Prime + Parallel Group 12-14 in Sequence 1-26 Non-Int in treasurehunt-epoch10of13 (03)	2731 Secs (2731 Secs) [==>]	[2]
<i>Comments: Following the June 4 2020 recommendations of J. Anderson (2020) "CURRENT CTE-MITIGATION RECOMMENDATIONS", we aim for a minimum background level of 20 e-/pix in each WFC3/UVIS F275W exposure. Taking into account the raised natural background of this pseudo-CVZ visit, the WFC3/UVIS ETC shows that this requirement becomes satisfied for FLASH=10. The APT Phase-II diagnostics seem to still test the older (now superseded) recommendation of a minimum of only 12 e-/pix, and therefore result in a warning that the specified postflash may be too high.</i>					
15	(1) JWST-NEP-TDF ACS/WFC, ACCUM, WFCENTER F435W	POS TARG 44.8,+3 65.200	Sequence 1-26 Non-Int in treasurehunt-epoch10of13 (03) Prime + Parallel Group 15-17 in Sequence 1-26 Non-Int in treasurehunt-epoch10of13 (03)	1245 Secs (1245 Secs) [==>]	[3]
<i>Comments: The specified POS_TARG values intentionally place the WFC3/UVIS and ACS/WFC instrument apertures off the coordinates of the target (i.e., the center of the JWST NEP Time-Domain Field) to their intended locations within an annulus surrounding the extant HST data.</i>					
16	(1) JWST-NEP-TDF ACS/WFC, ACCUM, WFCENTER F606W	POS TARG 44.8,+3 65.200	Sequence 1-26 Non-Int in treasurehunt-epoch10of13 (03) Prime + Parallel Group 15-17 in Sequence 1-26 Non-Int in treasurehunt-epoch10of13 (03)	1245 Secs (1245 Secs) [==>]	[3]
17	(WFC3UVI ANY S.im.1445613) WFC3/UVIS, ACCUM, UVIS F275W FLASH=10		Sequence 1-26 Non-Int in treasurehunt-epoch10of13 (03) Prime + Parallel Group 15-17 in Sequence 1-26 Non-Int in treasurehunt-epoch10of13 (03)	2714 Secs (2714 Secs) [==>]	[3]
<i>Comments: Following the June 4 2020 recommendations of J. Anderson (2020) "CURRENT CTE-MITIGATION RECOMMENDATIONS", we aim for a minimum background level of 20 e-/pix in each WFC3/UVIS F275W exposure. Taking into account the raised natural background of this pseudo-CVZ visit, the WFC3/UVIS ETC shows that this requirement becomes satisfied for FLASH=10. The APT Phase-II diagnostics seem to still test the older (now superseded) recommendation of a minimum of only 12 e-/pix, and therefore result in a warning that the specified postflash may be too high.</i>					

Proposal 16793 - treasurehunt-epoch10of13 (03) - TREASUREHUNT: Hubble's UV-Visible treasury imaging of the JWST NEP Time...

18	(1) JWST-NEP-TDF ACS/WFC, ACCUM, WFCENTER F606W	POS TARG +45.000 ,+365.200	Sequence 1-26 Non-Int in treasurehunt-epoch10of13 (03) Prime + Parallel Group 18-20 in Sequence 1-26 Non-Int in treasurehunt-epoch10of13 (03)	1253 Secs (1253 Secs) [==>]	[3]
<p><i>Comments: The specified POS_TARG values intentionally place the WFC3/UVIS and ACS/WFC instrument apertures off the coordinates of the target (i.e., the center of the JWST NEP Time-Domain Field) to their intended locations within an annulus surrounding the extant HST data.</i></p>					
19	(1) JWST-NEP-TDF ACS/WFC, ACCUM, WFCENTER F435W	POS TARG +45.000 ,+365.200	Sequence 1-26 Non-Int in treasurehunt-epoch10of13 (03) Prime + Parallel Group 18-20 in Sequence 1-26 Non-Int in treasurehunt-epoch10of13 (03)	1254 Secs (1254 Secs) [==>]	[3]
20	(WFC3UVI ANY S.im.1445613) WFC3/UVIS, ACCUM, UVIS F275W FLASH=10		Sequence 1-26 Non-Int in treasurehunt-epoch10of13 (03) Prime + Parallel Group 18-20 in Sequence 1-26 Non-Int in treasurehunt-epoch10of13 (03)	2731 Secs (2731 Secs) [==>]	[3]
<p><i>Comments: Following the June 4 2020 recommendations of J. Anderson (2020) "CURRENT CTE-MITIGATION RECOMMENDATIONS", we aim for a minimum background level of 20 e-/pix in each WFC3/UVIS F275W exposure. Taking into account the raised natural background of this pseudo-CVZ visit, the WFC3/UVIS ETC shows that this requirement becomes satisfied for FLASH=10. The APT Phase-II diagnostics seem to still test the older (now superseded) recommendation of a minimum of only 12 e-/pix, and therefore result in a warning that the specified postflash may be too high.</i></p>					
21	(1) JWST-NEP-TDF ACS/WFC, ACCUM, WFCENTER F435W	POS TARG 44.8,+365.000	Sequence 1-26 Non-Int in treasurehunt-epoch10of13 (03) Prime + Parallel Group 21-23 in Sequence 1-26 Non-Int in treasurehunt-epoch10of13 (03)	994 Secs (994 Secs) [==>]	[4]
<p><i>Comments: The specified POS_TARG values intentionally place the WFC3/UVIS and ACS/WFC instrument apertures off the coordinates of the target (i.e., the center of the JWST NEP Time-Domain Field) to their intended locations within an annulus surrounding the extant HST data.</i></p>					
22	(1) JWST-NEP-TDF ACS/WFC, ACCUM, WFCENTER F606W	POS TARG 44.8,+365.000	Sequence 1-26 Non-Int in treasurehunt-epoch10of13 (03) Prime + Parallel Group 21-23 in Sequence 1-26 Non-Int in treasurehunt-epoch10of13 (03)	994 Secs (994 Secs) [==>]	[4]
23	(WFC3UVI ANY S.im.1445644) WFC3/UVIS, ACCUM, UVIS F275W FLASH=12		Sequence 1-26 Non-Int in treasurehunt-epoch10of13 (03) Prime + Parallel Group 21-23 in Sequence 1-26 Non-Int in treasurehunt-epoch10of13 (03)	2212 Secs (2212 Secs) [==>]	[4]
<p><i>Comments: Following the June 4 2020 recommendations of J. Anderson (2020) "CURRENT CTE-MITIGATION RECOMMENDATIONS", we aim for a minimum background level of 20 e-/pix in each WFC3/UVIS F275W exposure. Taking into account the raised natural background of this pseudo-CVZ visit, the WFC3/UVIS ETC shows that this requirement becomes satisfied for FLASH=12. The APT Phase-II diagnostics seem to still test the older (now superseded) recommendation of a minimum of only 12 e-/pix, and therefore result in a warning that the specified postflash may be too high.</i></p>					

Proposal 16793 - treasurehunt-epoch10of13 (03) - TREASUREHUNT: Hubble's UV-Visible treasury imaging of the JWST NEP Time-...

24	(1) JWST-NEP-TDF ACS/WFC, ACCUM, WFCENTER F606W	POS TARG +45.000 ,+365.000	Sequence 1-26 Non-Int in treasurehunt-epoch10of13 (03) Prime + Parallel Group 24-26 in Sequence 1-26 Non-Int in treasurehunt-epoch10of13 (03)	997 Secs (997 Secs)	[==>]	[4]
<p><i>Comments: The specified POS_TARG values intentionally place the WFC3/UVIS and ACS/WFC instrument apertures off the coordinates of the target (i.e., the center of the JWST NEP Time-Domain Field) to their intended locations within an annulus surrounding the extant HST data.</i></p>						
25	(1) JWST-NEP-TDF ACS/WFC, ACCUM, WFCENTER F435W	POS TARG +45.000 ,+365.000	Sequence 1-26 Non-Int in treasurehunt-epoch10of13 (03) Prime + Parallel Group 24-26 in Sequence 1-26 Non-Int in treasurehunt-epoch10of13 (03)	997 Secs (997 Secs)	[==>]	[4]
26	(WFC3UVI ANY S.im.144564 4) WFC3/UVIS, ACCUM, UVIS	F275W FLASH=12	Sequence 1-26 Non-Int in treasurehunt-epoch10of13 (03) Prime + Parallel Group 24-26 in Sequence 1-26 Non-Int in treasurehunt-epoch10of13 (03)	2198 Secs (2198 Secs)	[==>]	[4]
<p><i>Comments: Following the June 4 2020 recommendations of J. Anderson (2020) "CURRENT CTE-MITIGATION RECOMMENDATIONS", we aim for a minimum background level of 20 e-/pix in each WFC3/UVIS F275W exposure. Taking into account the raised natural background of this pseudo-CVZ visit, the WFC3/UVIS ETC shows that this requirement becomes satisfied for FLASH=12. The APT Phase-II diagnostics seem to still test the older (now superseded) recommendation of a minimum of only 12 e-/pix, and therefore result in a warning that the specified postflash may be too high.</i></p>						

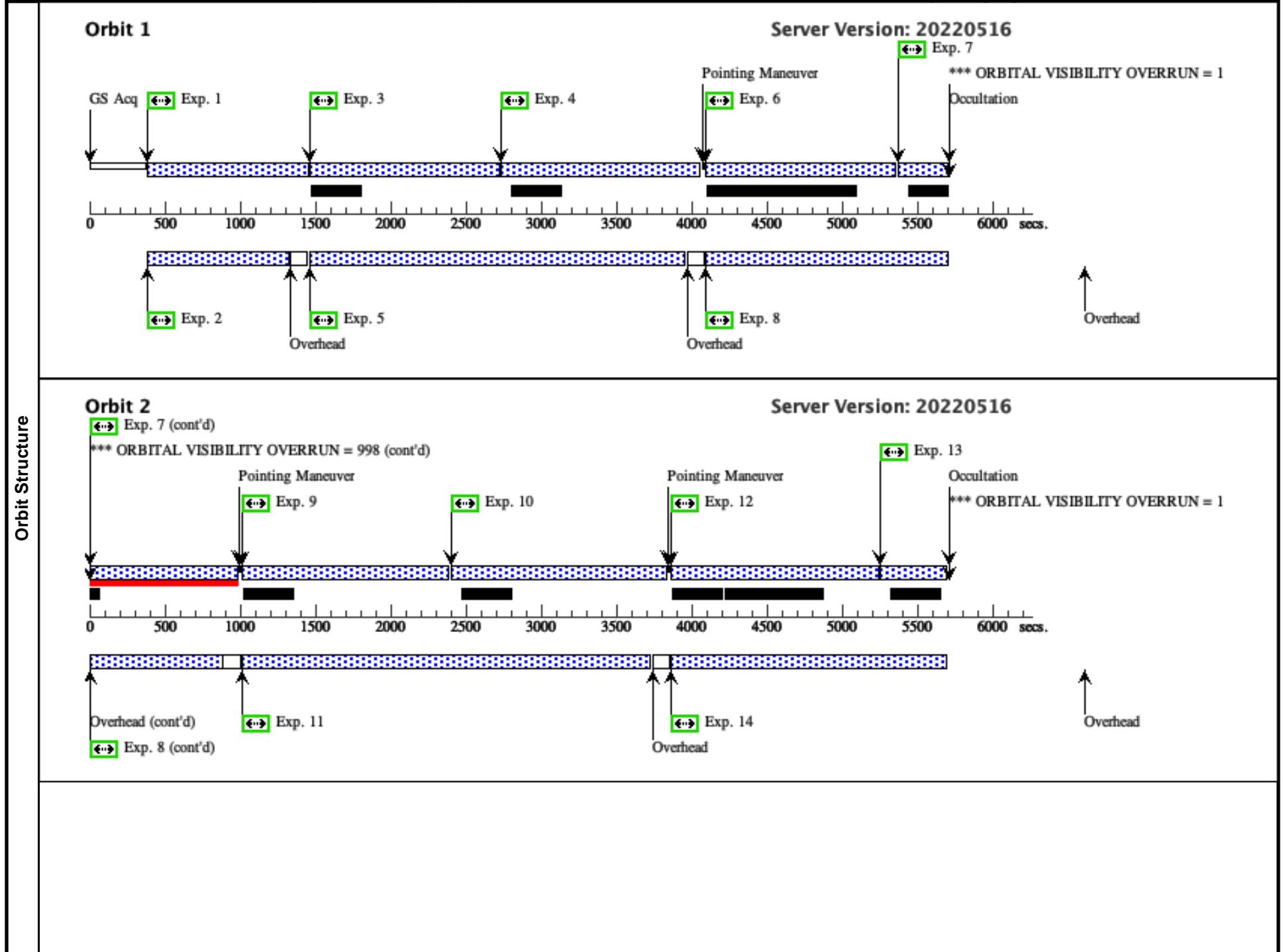

Orbit 3

Server Version: 20220516

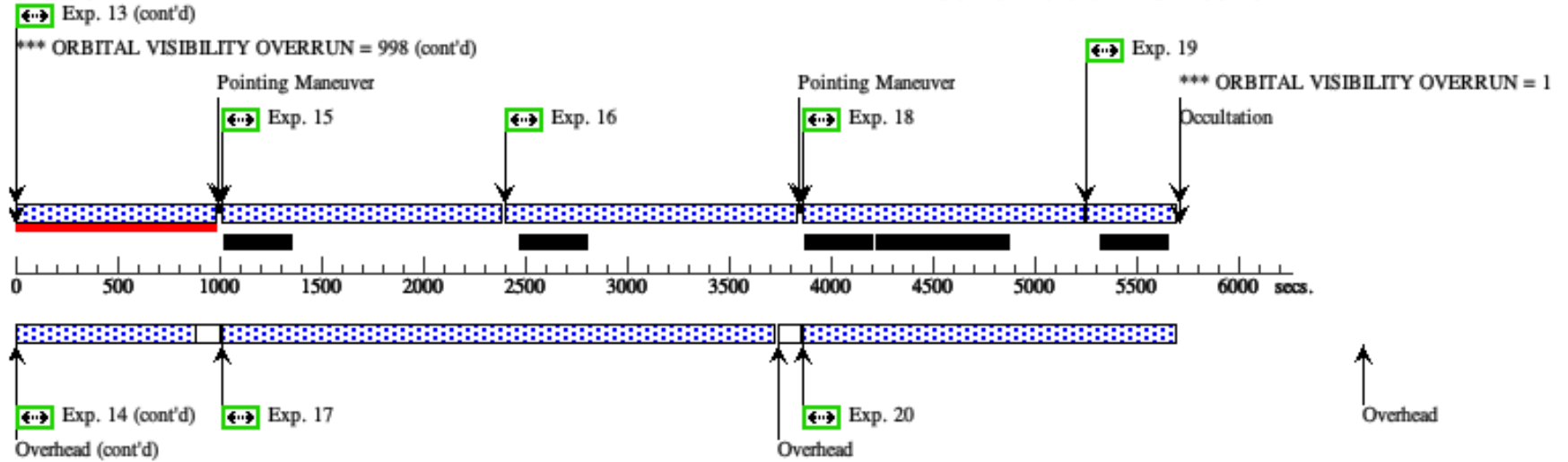

Orbit 4

Server Version: 20220516

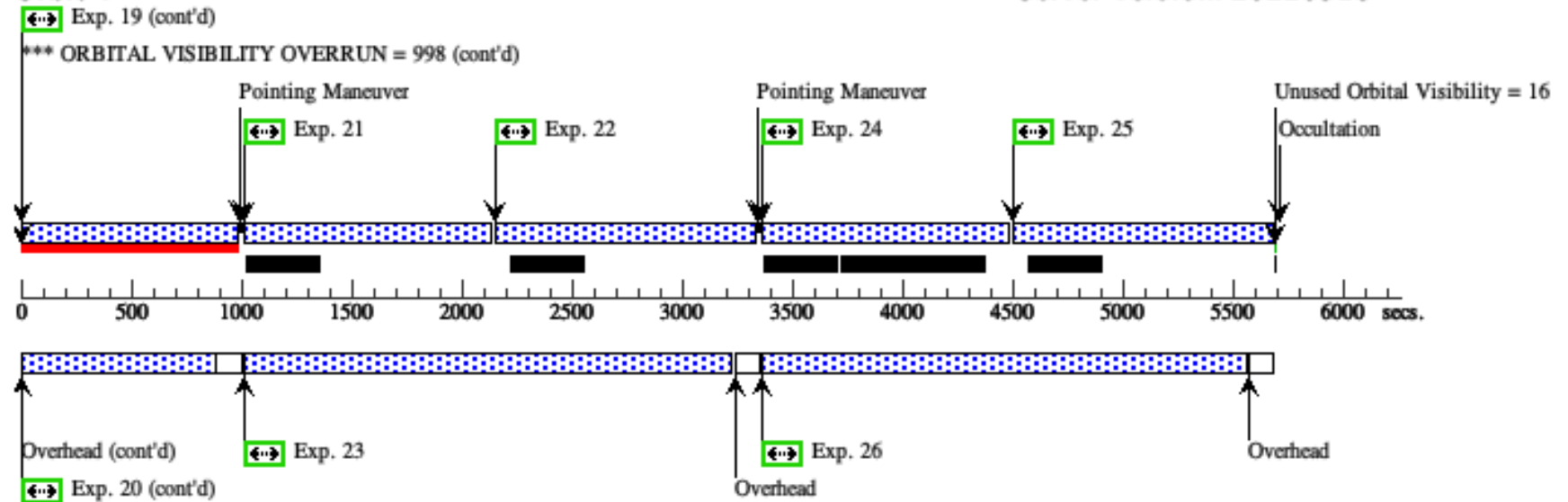

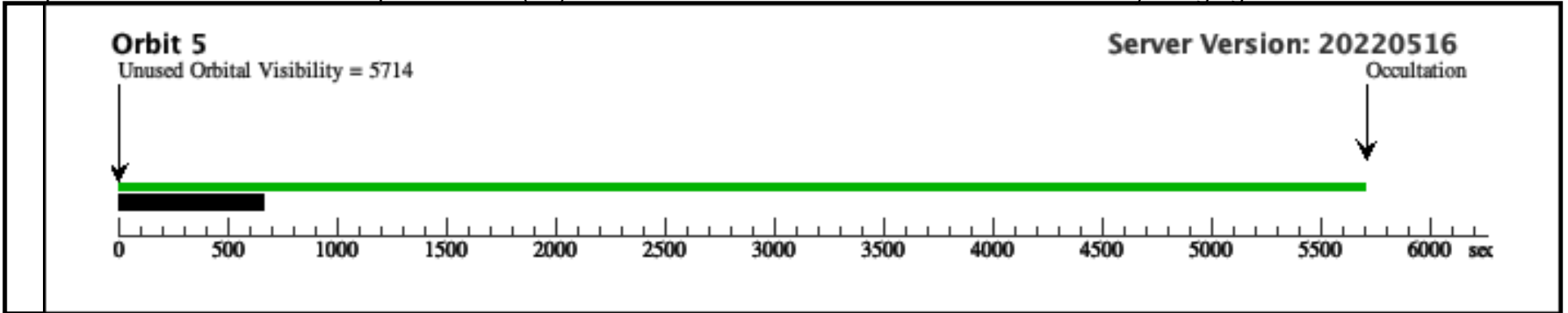

Visit	<p>Proposal 16793, treasurehunt-epoch11of13 (04), completed</p> <p>Diagnostic Status: Error</p> <p>Scientific Instruments: WFC3/UVIS, ACS/WFC</p> <p>Special Requirements: BRIGHT EARTH AVOID 13.5D; ORIENT 244D TO 244 D; BETWEEN 2022.083:20:03:42 AND 2022.083:20:09:42; BETWEEN 2022.084:16:42:24 AND 2022.084:16:48:24; BETWEEN 2022.085:16:31:40 AND 2022.085:16:37:40; BETWEEN 2022.086:17:56:14 AND 2022.086:18:02:14; BETWEEN 2022.087:14:34:57 AND 2022.087:14:40:57; BETWEEN 2022.088:14:24:17 AND 2022.088:14:30:17; BETWEEN 2022.089:14:13:39 AND 2022.089:14:19:39; BETWEEN 2022.090:12:27:45 AND 2022.090:12:33:45; BETWEEN 2022.091:12:17:12 AND 2022.091:12:23:12; VISIBILITY INTERVAL 5714 S</p> <p><i>Comments: Epoch 11 of 13 is a 4-orbit (pseudo)CVZ visit, using the opportunity at ORIENT = 244 degrees. After guide star acquisition at the start of the first orbit, the guide star remains visible and locked for the duration of the visit, so no guide star re-acquisition in subsequent orbits will be required in orbits 2--4. This strategy is the same as adopted for GO-15278 in Cycle 25, and as successfully executed through Cycle 28. Specified POS_TARGs with respect to the nominal field center place the instrument apertures at the intended location within the 13-epoch pattern. While APT throws an error for the specified Bright Earth Avoidance angle of 13.5 degrees, this value is intended, and proven to schedule and execute successfully for a pseudo-CVZ visit.</i></p>																	
	Diagnostics	<p>(treasurehunt-epoch11of13 (04)) Error (Form): The specified Bright Earth Avoidance angle is outside the permitted range.</p> <p>(treasurehunt-epoch11of13 (04)) Warning (Orbit Planner): NO VISIBILITY TABLE CORRESPONDING TO BRIGHT EARTH AVOIDANCE ANGLE</p> <p>(treasurehunt-epoch11of13 (04)) Warning (Orbit Planner): ORBITAL VISIBILITY OVERRUN</p> <p>(treasurehunt-epoch11of13 (04)) Warning (Orbit Planner): ORBITAL VISIBILITY OVERRUN</p> <p>(treasurehunt-epoch11of13 (04)) Warning (Orbit Planner): ORBITAL VISIBILITY OVERRUN</p> <p>(treasurehunt-epoch11of13 (04)) Warning (Orbit Planner): ORBITAL VISIBILITY OVERRUN</p> <p>(treasurehunt-epoch11of13 (04)) Warning (Orbit Planner): ORBITAL VISIBILITY OVERRUN</p> <p>(treasurehunt-epoch11of13 (04)) Warning (Orbit Planner): ORBITAL VISIBILITY OVERRUN</p> <p>(treasurehunt-epoch11of13 (04)) Warning (Orbit Planner): POS TARG OUTSIDE OF APERTURE</p> <p>(treasurehunt-epoch11of13 (04)) Warning (Orbit Planner): POS TARG OUTSIDE OF APERTURE</p> <p>(treasurehunt-epoch11of13 (04)) Warning (Orbit Planner): POS TARG OUTSIDE OF APERTURE</p> <p>(treasurehunt-epoch11of13 (04)) Warning (Orbit Planner): POS TARG OUTSIDE OF APERTURE</p> <p>(treasurehunt-epoch11of13 (04)) Warning (Orbit Planner): POS TARG OUTSIDE OF APERTURE</p> <p>(treasurehunt-epoch11of13 (04)) Warning (Orbit Planner): POS TARG OUTSIDE OF APERTURE</p> <p>(treasurehunt-epoch11of13 (04)) Warning (Orbit Planner): POS TARG OUTSIDE OF APERTURE</p> <p>(treasurehunt-epoch11of13 (04)) Warning (Orbit Planner): POS TARG OUTSIDE OF APERTURE</p> <p>(treasurehunt-epoch11of13 (04)) Warning (Orbit Planner): POS TARG OUTSIDE OF APERTURE</p> <p>(treasurehunt-epoch11of13 (04)) Warning (Orbit Planner): POS TARG OUTSIDE OF APERTURE</p> <p>(treasurehunt-epoch11of13 (04)) Warning (Orbit Planner): POS TARG OUTSIDE OF APERTURE</p> <p>(treasurehunt-epoch11of13 (04)) Warning (Orbit Planner): POS TARG OUTSIDE OF APERTURE</p> <p>(treasurehunt-epoch11of13 (04)) Warning (Orbit Planner): POS TARG OUTSIDE OF APERTURE</p>																
Fixed Targets		<table border="1"> <thead> <tr> <th>#</th> <th>Name</th> <th>Target Coordinates</th> <th>Targ. Coord. Corrections</th> <th>Fluxes</th> <th>Miscellaneous</th> </tr> </thead> <tbody> <tr> <td>(1)</td> <td>JWST-NEP-TDF</td> <td>RA: 17 22 47.8960 (260.6995667d) Dec: +65 49 21.54 (65.82265d) Equinox: J2000</td> <td></td> <td>V=27.0+/-1.0</td> <td>Reference Frame: ICRS</td> </tr> </tbody> </table> <p><i>Comments: The target field is centered on the extant HST observations of the JWST NEP Time-Domain Field of GO-15278. Allocated JWST GTO observations will provide both NIRCcam imaging and NIRISS slitless spectroscopy in this field, which was defined to be the cleanest ~14' diameter area in JWST's northern continuous viewing zone, where JWST will conduct a deep extragalactic time-domain survey, with added utility for extreme outer solar system and near-Galactic time-domain science. The JWST NEP Time-Domain Field is developed as a *community field*, and has deep coverage across the electromagnetic spectrum from X-ray through long-wave radio. The present Cycle 28+29 HST program will complete near-contiguous 3-filter coverage in the UV-Visible, targeting the annulus surrounding the extant HST observations of GO-15278. The present Phase-II APT specifies the Cycle 29 pointings within that annulus.</i></p> <p>Category=UNIDENTIFIED</p> <p>Description=[HIGH LATITUDE FIELD, INFRARED EMITTER, OPTICAL EMITTER, ULTRAVIOLET EMITTER]</p>					#	Name	Target Coordinates	Targ. Coord. Corrections	Fluxes	Miscellaneous	(1)	JWST-NEP-TDF	RA: 17 22 47.8960 (260.6995667d) Dec: +65 49 21.54 (65.82265d) Equinox: J2000		V=27.0+/-1.0	Reference Frame: ICRS
		#	Name	Target Coordinates	Targ. Coord. Corrections	Fluxes	Miscellaneous											
(1)		JWST-NEP-TDF	RA: 17 22 47.8960 (260.6995667d) Dec: +65 49 21.54 (65.82265d) Equinox: J2000		V=27.0+/-1.0	Reference Frame: ICRS												

Proposal 16793 - treasurehunt-epoch11of13 (04) - TREASUREHUNT: Hubble's UV-Visible treasury imaging of the JWST NEP Time...

#	Label (ETC Run)	Target	Config,Mode,Aperture	Spectral Els.	Opt. Params.	Special Reqs.	Groups	Exp. Time (Total)/[Actual Dur.]	Orbit
1		(1) JWST-NEP-TDF	ACS/WFC, ACCUM, WFCENTER	F435W		POS TARG 44.9,+375.100	Sequence 1-24 Non-Int in treasurehunt-epoch11of13 (04) Prime + Parallel Group 1-3 in Sequence 1-24 Non-Int in treasurehunt-epoch11of13 (04)	1136 Secs (1136 Secs) [==>]	[1]
<p><i>Comments: The specified POS_TARG values intentionally place the WFC3/UVIS and ACS/WFC instrument apertures off the coordinates of the target (i.e., the center of the JWST NEP Time-Domain Field) to their intended locations within an annulus surrounding the extant HST data.</i></p>									
2		(1) JWST-NEP-TDF	ACS/WFC, ACCUM, WFCENTER	F606W		POS TARG 44.9,+375.100	Sequence 1-24 Non-Int in treasurehunt-epoch11of13 (04) Prime + Parallel Group 1-3 in Sequence 1-24 Non-Int in treasurehunt-epoch11of13 (04)	1136 Secs (1136 Secs) [==>]	[1]
3	(WFC3UVIS.im.1445613)	ANY	WFC3/UVIS, ACCUM, UVIS	F275W	FLASH=11		Sequence 1-24 Non-Int in treasurehunt-epoch11of13 (04) Prime + Parallel Group 1-3 in Sequence 1-24 Non-Int in treasurehunt-epoch11of13 (04)	2545 Secs (2545 Secs) [==>]	[1]
<p><i>Comments: Following the June 4 2020 recommendations of J. Anderson (2020) "CURRENT CTE-MITIGATION RECOMMENDATIONS", we aim for a minimum background level of 20 e-/pix in each WFC3/UVIS F275W exposure. Taking into account the raised natural background of this pseudo-CVZ visit, the WFC3/UVIS ETC shows that this requirement becomes satisfied for FLASH=11. The APT Phase-II diagnostics seem to still test the older (now superseded) recommendation of a minimum of only 12 e-/pix, and therefore result in a warning that the specified postflash may be too high.</i></p>									
4		(1) JWST-NEP-TDF	ACS/WFC, ACCUM, WFCENTER	F606W		POS TARG +45.100,+375.100	Sequence 1-24 Non-Int in treasurehunt-epoch11of13 (04) Prime + Parallel Group 4-6 in Sequence 1-24 Non-Int in treasurehunt-epoch11of13 (04)	1140 Secs (1140 Secs) [==>]	[1]
<p><i>Comments: The specified POS_TARG values intentionally place the WFC3/UVIS and ACS/WFC instrument apertures off the coordinates of the target (i.e., the center of the JWST NEP Time-Domain Field) to their intended locations within an annulus surrounding the extant HST data.</i></p>									
5		(1) JWST-NEP-TDF	ACS/WFC, ACCUM, WFCENTER	F435W		POS TARG +45.100,+375.100	Sequence 1-24 Non-Int in treasurehunt-epoch11of13 (04) Prime + Parallel Group 4-6 in Sequence 1-24 Non-Int in treasurehunt-epoch11of13 (04)	1140 Secs (1140 Secs) [==>]	[1]

Exposures

Proposal 16793 - treasurehunt-epoch11of13 (04) - TREASUREHUNT: Hubble's UV-Visible treasury imaging of the JWST NEP Time...

6	(WFC3UVI ANY S.im.144561 3)	WFC3/UVIS, ACCUM, UVIS	F275W	FLASH=11		Sequence 1-24 Non-Int in treasurehunt-epoch11of13 (04) Prime + Parallel Group 4-6 in Sequence 1-24 Non-Int in treasurehunt-epoch11of13 (04)	2504 Secs (2504 Secs) [==>]	[1]
<p><i>Comments: Following the June 4 2020 recommendations of J. Anderson (2020) "CURRENT CTE-MITIGATION RECOMMENDATIONS", we aim for a minimum background level of 20 e-/pix in each WFC3/UVIS F275W exposure. Taking into account the raised natural background of this pseudo-CVZ visit, the WFC3/UVIS ETC shows that this requirement becomes satisfied for FLASH=11. The APT Phase-II diagnostics seem to still test the older (now superseded) recommendation of a minimum of only 12 e-/pix, and therefore result in a warning that the specified postflash may be too high.</i></p>								
7	(1) JWST-NEP-TDF	ACS/WFC, ACCUM, WFCENTER	F435W		POS TARG 44.9,+3 74.900	Sequence 1-24 Non-Int in treasurehunt-epoch11of13 (04) Prime + Parallel Group 7-9 in Sequence 1-24 Non-Int in treasurehunt-epoch11of13 (04)	1245 Secs (1245 Secs) [==>]	[2]
<p><i>Comments: The specified POS_TARG values intentionally place the WFC3/UVIS and ACS/WFC instrument apertures off the coordinates of the target (i.e., the center of the JWST NEP Time-Domain Field) to their intended locations within an annulus surrounding the extant HST data.</i></p>								
8	(1) JWST-NEP-TDF	ACS/WFC, ACCUM, WFCENTER	F606W		POS TARG 44.9,+3 74.900	Sequence 1-24 Non-Int in treasurehunt-epoch11of13 (04) Prime + Parallel Group 7-9 in Sequence 1-24 Non-Int in treasurehunt-epoch11of13 (04)	1245 Secs (1245 Secs) [==>]	[2]
9	(WFC3UVI ANY S.im.144561 3)	WFC3/UVIS, ACCUM, UVIS	F275W	FLASH=10		Sequence 1-24 Non-Int in treasurehunt-epoch11of13 (04) Prime + Parallel Group 7-9 in Sequence 1-24 Non-Int in treasurehunt-epoch11of13 (04)	2714 Secs (2714 Secs) [==>]	[2]
<p><i>Comments: Following the June 4 2020 recommendations of J. Anderson (2020) "CURRENT CTE-MITIGATION RECOMMENDATIONS", we aim for a minimum background level of 20 e-/pix in each WFC3/UVIS F275W exposure. Taking into account the raised natural background of this pseudo-CVZ visit, the WFC3/UVIS ETC shows that this requirement becomes satisfied for FLASH=10. The APT Phase-II diagnostics seem to still test the older (now superseded) recommendation of a minimum of only 12 e-/pix, and therefore result in a warning that the specified postflash may be too high.</i></p>								
10	(1) JWST-NEP-TDF	ACS/WFC, ACCUM, WFCENTER	F606W		POS TARG +45.100 ,+374.900	Sequence 1-24 Non-Int in treasurehunt-epoch11of13 (04) Prime + Parallel Group 10-12 in Sequence 1-24 Non-Int in treasurehunt-epoch11of13 (04)	1253 Secs (1253 Secs) [==>]	[2]
<p><i>Comments: The specified POS_TARG values intentionally place the WFC3/UVIS and ACS/WFC instrument apertures off the coordinates of the target (i.e., the center of the JWST NEP Time-Domain Field) to their intended locations within an annulus surrounding the extant HST data.</i></p>								
11	(1) JWST-NEP-TDF	ACS/WFC, ACCUM, WFCENTER	F435W		POS TARG +45.100 ,+374.900	Sequence 1-24 Non-Int in treasurehunt-epoch11of13 (04) Prime + Parallel Group 10-12 in Sequence 1-24 Non-Int in treasurehunt-epoch11of13 (04)	1254 Secs (1254 Secs) [==>]	[2]

Proposal 16793 - treasurehunt-epoch11of13 (04) - TREASUREHUNT: Hubble's UV-Visible treasury imaging of the JWST NEP Time...

12	(WFC3UVI ANY S.im.1445613)	WFC3/UVIS, ACCUM, UVIS	F275W	FLASH=10		Sequence 1-24 Non-Int in treasurehunt-epoch11of13 (04) Prime + Parallel Group 10-12 in Sequence 1-24 Non-Int in treasurehunt-epoch11of13 (04)	2731 Secs (2731 Secs) [==>]	[2]
<p>Comments: Following the June 4 2020 recommendations of J. Anderson (2020) "CURRENT CTE-MITIGATION RECOMMENDATIONS", we aim for a minimum background level of 20 e-/pix in each WFC3/UVIS F275W exposure. Taking into account the raised natural background of this pseudo-CVZ visit, the WFC3/UVIS ETC shows that this requirement becomes satisfied for FLASH=10. The APT Phase-II diagnostics seem to still test the older (now superseded) recommendation of a minimum of only 12 e-/pix, and therefore result in a warning that the specified postflash may be too high.</p>								
13	(1) JWST-NEP-TDF	ACS/WFC, ACCUM, WFCENTER	F435W		POS TARG 44.8,+375.200	Sequence 1-24 Non-Int in treasurehunt-epoch11of13 (04) Prime + Parallel Group 13-15 in Sequence 1-24 Non-Int in treasurehunt-epoch11of13 (04)	1245 Secs (1245 Secs) [==>]	[3]
<p>Comments: The specified POS_TARG values intentionally place the WFC3/UVIS and ACS/WFC instrument apertures off the coordinates of the target (i.e., the center of the JWST NEP Time-Domain Field) to their intended locations within an annulus surrounding the extant HST data.</p>								
14	(1) JWST-NEP-TDF	ACS/WFC, ACCUM, WFCENTER	F606W		POS TARG 44.8,+375.200	Sequence 1-24 Non-Int in treasurehunt-epoch11of13 (04) Prime + Parallel Group 13-15 in Sequence 1-24 Non-Int in treasurehunt-epoch11of13 (04)	1245 Secs (1245 Secs) [==>]	[3]
15	(WFC3UVI ANY S.im.1445613)	WFC3/UVIS, ACCUM, UVIS	F275W	FLASH=10		Sequence 1-24 Non-Int in treasurehunt-epoch11of13 (04) Prime + Parallel Group 13-15 in Sequence 1-24 Non-Int in treasurehunt-epoch11of13 (04)	2714 Secs (2714 Secs) [==>]	[3]
<p>Comments: Following the June 4 2020 recommendations of J. Anderson (2020) "CURRENT CTE-MITIGATION RECOMMENDATIONS", we aim for a minimum background level of 20 e-/pix in each WFC3/UVIS F275W exposure. Taking into account the raised natural background of this pseudo-CVZ visit, the WFC3/UVIS ETC shows that this requirement becomes satisfied for FLASH=10. The APT Phase-II diagnostics seem to still test the older (now superseded) recommendation of a minimum of only 12 e-/pix, and therefore result in a warning that the specified postflash may be too high.</p>								
16	(1) JWST-NEP-TDF	ACS/WFC, ACCUM, WFCENTER	F606W		POS TARG +45.000,+375.200	Sequence 1-24 Non-Int in treasurehunt-epoch11of13 (04) Prime + Parallel Group 16-18 in Sequence 1-24 Non-Int in treasurehunt-epoch11of13 (04)	1253 Secs (1253 Secs) [==>]	[3]
<p>Comments: The specified POS_TARG values intentionally place the WFC3/UVIS and ACS/WFC instrument apertures off the coordinates of the target (i.e., the center of the JWST NEP Time-Domain Field) to their intended locations within an annulus surrounding the extant HST data.</p>								
17	(1) JWST-NEP-TDF	ACS/WFC, ACCUM, WFCENTER	F435W		POS TARG +45.000,+375.200	Sequence 1-24 Non-Int in treasurehunt-epoch11of13 (04) Prime + Parallel Group 16-18 in Sequence 1-24 Non-Int in treasurehunt-epoch11of13 (04)	1254 Secs (1254 Secs) [==>]	[3]

Proposal 16793 - treasurehunt-epoch11of13 (04) - TREASUREHUNT: Hubble's UV-Visible treasury imaging of the JWST NEP Time...

18	(WFC3UVI ANY S.im.1445613)	WFC3/UVIS, ACCUM, UVIS	F275W	FLASH=10		Sequence 1-24 Non-Int in treasurehunt-epoch11of13 (04) Prime + Parallel Group 16-18 in Sequence 1-24 Non-Int in treasurehunt-epoch11of13 (04)	2731 Secs (2731 Secs) [==>]	[3]
<p>Comments: Following the June 4 2020 recommendations of J. Anderson (2020) "CURRENT CTE-MITIGATION RECOMMENDATIONS", we aim for a minimum background level of 20 e-/pix in each WFC3/UVIS F275W exposure. Taking into account the raised natural background of this pseudo-CVZ visit, the WFC3/UVIS ETC shows that this requirement becomes satisfied for FLASH=10. The APT Phase-II diagnostics seem to still test the older (now superseded) recommendation of a minimum of only 12 e-/pix, and therefore result in a warning that the specified postflash may be too high.</p>								
19	(1) JWST-NEP-TDF	ACS/WFC, ACCUM, WFCENTER	F435W		POS TARG 44.8,+375.000	Sequence 1-24 Non-Int in treasurehunt-epoch11of13 (04) Prime + Parallel Group 19-21 in Sequence 1-24 Non-Int in treasurehunt-epoch11of13 (04)	994 Secs (994 Secs) [==>]	[4]
<p>Comments: The specified POS_TARG values intentionally place the WFC3/UVIS and ACS/WFC instrument apertures off the coordinates of the target (i.e., the center of the JWST NEP Time-Domain Field) to their intended locations within an annulus surrounding the extant HST data.</p>								
20	(1) JWST-NEP-TDF	ACS/WFC, ACCUM, WFCENTER	F606W		POS TARG 44.8,+375.000	Sequence 1-24 Non-Int in treasurehunt-epoch11of13 (04) Prime + Parallel Group 19-21 in Sequence 1-24 Non-Int in treasurehunt-epoch11of13 (04)	994 Secs (994 Secs) [==>]	[4]
21	(WFC3UVI ANY S.im.1445644)	WFC3/UVIS, ACCUM, UVIS	F275W	FLASH=12		Sequence 1-24 Non-Int in treasurehunt-epoch11of13 (04) Prime + Parallel Group 19-21 in Sequence 1-24 Non-Int in treasurehunt-epoch11of13 (04)	2212 Secs (2212 Secs) [==>]	[4]
<p>Comments: Following the June 4 2020 recommendations of J. Anderson (2020) "CURRENT CTE-MITIGATION RECOMMENDATIONS", we aim for a minimum background level of 20 e-/pix in each WFC3/UVIS F275W exposure. Taking into account the raised natural background of this pseudo-CVZ visit, the WFC3/UVIS ETC shows that this requirement becomes satisfied for FLASH=12. The APT Phase-II diagnostics seem to still test the older (now superseded) recommendation of a minimum of only 12 e-/pix, and therefore result in a warning that the specified postflash may be too high.</p>								
22	(1) JWST-NEP-TDF	ACS/WFC, ACCUM, WFCENTER	F606W		POS TARG +45.000,+375.000	Sequence 1-24 Non-Int in treasurehunt-epoch11of13 (04) Prime + Parallel Group 22-24 in Sequence 1-24 Non-Int in treasurehunt-epoch11of13 (04)	997 Secs (997 Secs) [==>]	[4]
<p>Comments: The specified POS_TARG values intentionally place the WFC3/UVIS and ACS/WFC instrument apertures off the coordinates of the target (i.e., the center of the JWST NEP Time-Domain Field) to their intended locations within an annulus surrounding the extant HST data.</p>								
23	(1) JWST-NEP-TDF	ACS/WFC, ACCUM, WFCENTER	F435W		POS TARG +45.000,+375.000	Sequence 1-24 Non-Int in treasurehunt-epoch11of13 (04) Prime + Parallel Group 22-24 in Sequence 1-24 Non-Int in treasurehunt-epoch11of13 (04)	997 Secs (997 Secs) [==>]	[4]

Proposal 16793 - treasurehunt-epoch11of13 (04) - TREASUREHUNT: Hubble's UV-Visible treasury imaging of the JWST NEP Time-...

24	(WFC3UVI ANY S.im.144564 4)	WFC3/UVIS, ACCUM, UVIS	F275W	FLASH=12	Sequence 1-24 Non-Int in treasurehunt-epoch11of13 (04) Prime + Parallel Group 22-24 in Sequence 1-24 Non-Int in treasurehunt-epoch11of13 (04)	2198 Secs (2198 Secs) [==>]	[4]
<p><i>Comments: Following the June 4 2020 recommendations of J. Anderson (2020) "CURRENT CTE-MITIGATION RECOMMENDATIONS", we aim for a minimum background level of 20 e-/pix in each WFC3/UVIS F275W exposure. Taking into account the raised natural background of this pseudo-CVZ visit, the WFC3/UVIS ETC shows that this requirement becomes satisfied for FLASH=12. The APT Phase-II diagnostics seem to still test the older (now superseded) recommendation of a minimum of only 12 e-/pix, and therefore result in a warning that the specified postflash may be too high.</i></p>							

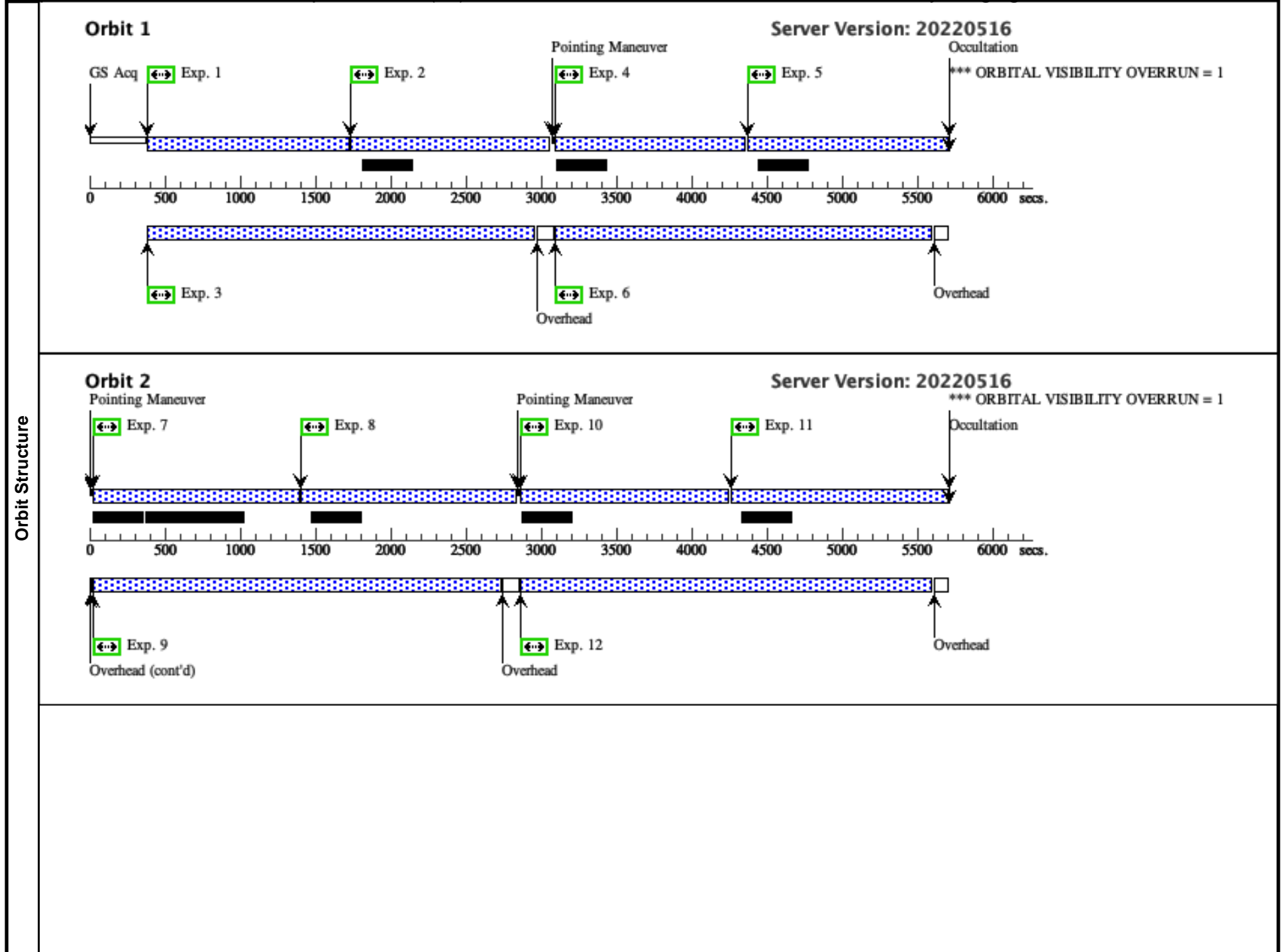

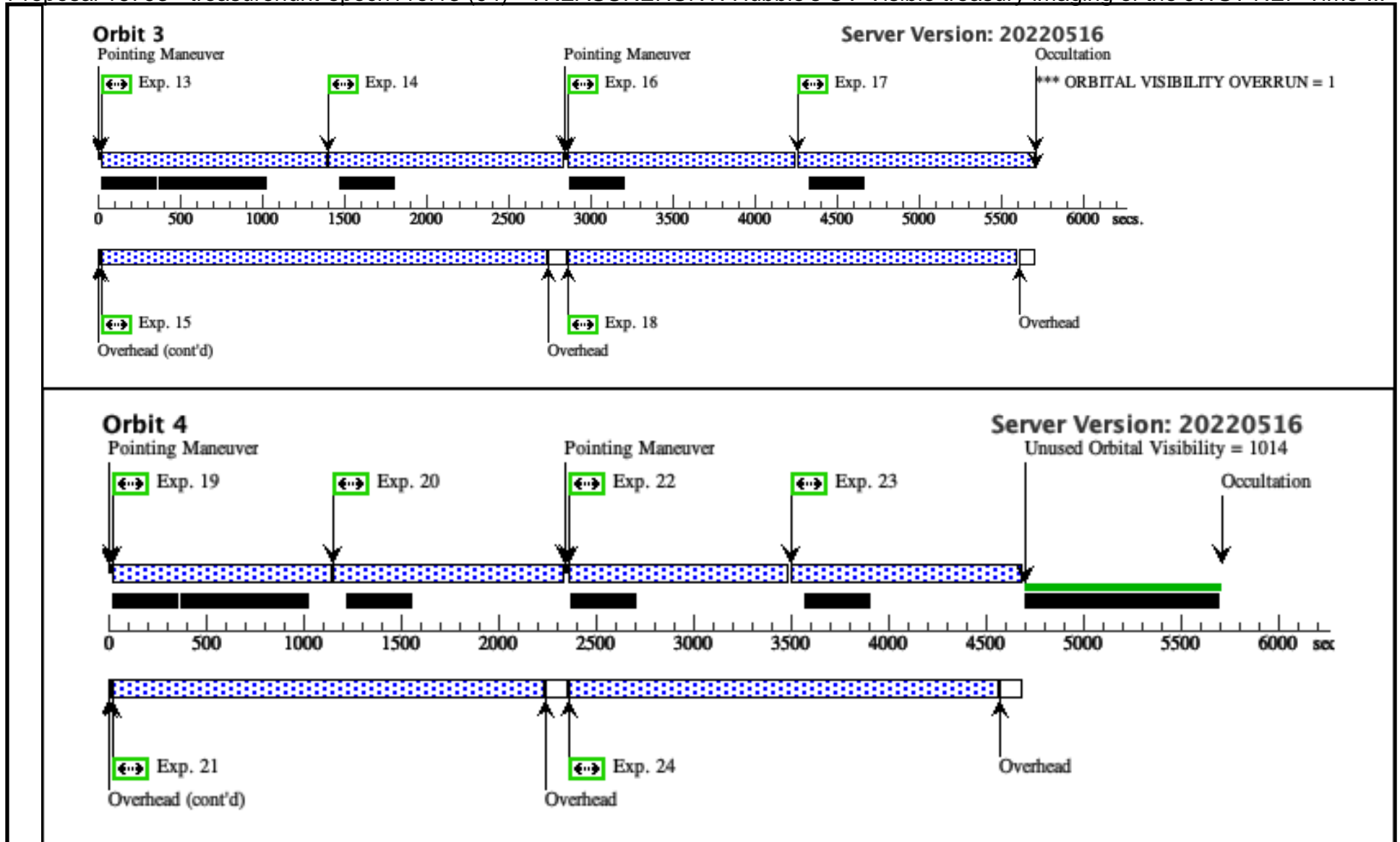

Proposal 16793 - treasurehunt-epoch12of13 (05) - TREASUREHUNT: Hubble's UV-Visible treasury imaging of the JWST NEP Time-...

Fixed Targets	#	Name	Target Coordinates	Targ. Coord. Corrections	Fluxes	Miscellaneous
	(1)	JWST-NEP-TDF	RA: 17 22 47.8960 (260.6995667d) Dec: +65 49 21.54 (65.82265d) Equinox: J2000		V=27.0+/-1.0	Reference Frame: ICRS
	<p><i>Comments: The target field is centered on the extant HST observations of the JWST NEP Time-Domain Field of GO-15278. Allocated JWST GTO observations will provide both NIRCам imaging and NIRISS slitless spectroscopy in this field, which was defined to be the cleanest ~14' diameter area in JWST's northern continuous viewing zone, where JWST will conduct a deep extragalactic time-domain survey, with added utility for extreme outer solar system and near-Galactic time-domain science. The JWST NEP Time-Domain Field is developed as a *community field*, and has deep coverage accross the electromagnetic spectrum from X-ray through long-wave radio. The present Cycle 28+29 HST program will complete near-contiguous 3-filter coverage in the UV--Visible, targeting the annulus surrounding the extant HST observations of GO-15278. The present Phase-II APT specifies the Cycle 29 pointings within that annulus.</i></p> <p>Category=UNIDENTIFIED Description=[HIGH LATITUDE FIELD, INFRARED EMITTER, OPTICAL EMITTER, ULTRAVIOLET EMITTER]</p>					

Proposal 16793 - treasurehunt-epoch12of13 (05) - TREASUREHUNT: Hubble's UV-Visible treasury imaging of the JWST NEP Time...

#	Label (ETC Run)	Target	Config,Mode,Aperture	Spectral Els.	Opt. Params.	Special Reqs.	Groups	Exp. Time (Total)/[Actual Dur.]	Orbit
1		(1) JWST-NEP-TDF	ACS/WFC, ACCUM, WFCENTER	F435W		POS TARG 44.9,+3 65.100	Sequence 1-26 Non-Int in treasurehunt-epoch12of13 (05) Prime + Parallel Group 1-2 in Sequence 1-26 Non-Int in treasurehunt-epoch12of13 (05)	680 Secs (680 Secs) [==>]	[1]
<p><i>Comments: The specified POS_TARG values intentionally place the WFC3/UVIS and ACS/WFC instrument apertures off the coordinates of the target (i.e., the center of the JWST NEP Time-Domain Field) to their intended locations within an annulus surrounding the extant HST data.</i></p>									
2	(WFC3UVIS.im.1445613)	ANY	WFC3/UVIS, ACCUM, UVIS	F275W	FLASH=12		Sequence 1-26 Non-Int in treasurehunt-epoch12of13 (05) Prime + Parallel Group 1-2 in Sequence 1-26 Non-Int in treasurehunt-epoch12of13 (05)	733 Secs (733 Secs) [==>]	[1]
<p><i>Comments: Following the June 4 2020 recommendations of J. Anderson (2020) "CURRENT CTE-MITIGATION RECOMMENDATIONS", we aim for a minimum background level of 20 e-/pix in each WFC3/UVIS F275W exposure. Taking into account the raised natural background of this pseudo-CVZ visit, this requirement becomes satisfied for FLASH=10. APT has no knowledge of this raised natural background, hence issues a warning.</i></p>									
3		(1) JWST-NEP-TDF	ACS/WFC, ACCUM, WFCENTER	F435W		POS TARG 44.9,+3 65.100	Sequence 1-26 Non-Int in treasurehunt-epoch12of13 (05) Prime + Parallel Group 3-5 in Sequence 1-26 Non-Int in treasurehunt-epoch12of13 (05)	1136 Secs (1136 Secs) [==>]	[1]
<p><i>Comments: The specified POS_TARG values intentionally place the WFC3/UVIS and ACS/WFC instrument apertures off the coordinates of the target (i.e., the center of the JWST NEP Time-Domain Field) to their intended locations within an annulus surrounding the extant HST data.</i></p>									
4		(1) JWST-NEP-TDF	ACS/WFC, ACCUM, WFCENTER	F606W		POS TARG 44.9,+3 65.100	Sequence 1-26 Non-Int in treasurehunt-epoch12of13 (05) Prime + Parallel Group 3-5 in Sequence 1-26 Non-Int in treasurehunt-epoch12of13 (05)	1136 Secs (1136 Secs) [==>]	[1]
5	(WFC3UVIS.im.1445613)	ANY	WFC3/UVIS, ACCUM, UVIS	F275W	FLASH=10		Sequence 1-26 Non-Int in treasurehunt-epoch12of13 (05) Prime + Parallel Group 3-5 in Sequence 1-26 Non-Int in treasurehunt-epoch12of13 (05)	2545 Secs (2545 Secs) [==>]	[1]
<p><i>Comments: Following the June 4 2020 recommendations of J. Anderson (2020) "CURRENT CTE-MITIGATION RECOMMENDATIONS", we aim for a minimum background level of 20 e-/pix in each WFC3/UVIS F275W exposure. Taking into account the raised natural background of this pseudo-CVZ visit, this requirement becomes satisfied for FLASH=10. APT has no knowledge of this raised natural background, hence issues a warning.</i></p>									

Proposal 16793 - treasurehunt-epoch12of13 (05) - TREASUREHUNT: Hubble's UV-Visible treasury imaging of the JWST NEP Time-...

6	(1) JWST-NEP-TDF ACS/WFC, ACCUM, WFCENTER F606W	POS TARG +45.100 ,+365.100	Sequence 1-26 Non-Int in treasurehunt-epoch12of13 (05) Prime + Parallel Group 6-8 in Sequence 1-26 Non-Int in treasurehunt-epoch12of13 (05)	1140 Secs (1140 Secs) [==>]	[1]
<p><i>Comments: The specified POS_TARG values intentionally place the WFC3/UVIS and ACS/WFC instrument apertures off the coordinates of the target (i.e., the center of the JWST NEP Time-Domain Field) to their intended locations within an annulus surrounding the extant HST data.</i></p>					
7	(1) JWST-NEP-TDF ACS/WFC, ACCUM, WFCENTER F435W	POS TARG +45.100 ,+365.100	Sequence 1-26 Non-Int in treasurehunt-epoch12of13 (05) Prime + Parallel Group 6-8 in Sequence 1-26 Non-Int in treasurehunt-epoch12of13 (05)	1140 Secs (1140 Secs) [==>]	[1]
8	(WFC3UVI ANY S.im.1445613) WFC3/UVIS, ACCUM, UVIS F275W FLASH=10		Sequence 1-26 Non-Int in treasurehunt-epoch12of13 (05) Prime + Parallel Group 6-8 in Sequence 1-26 Non-Int in treasurehunt-epoch12of13 (05)	2504 Secs (2504 Secs) [==>]	[1]
<p><i>Comments: Following the June 4 2020 recommendations of J. Anderson (2020) "CURRENT CTE-MITIGATION RECOMMENDATIONS", we aim for a minimum background level of 20 e-/pix in each WFC3/UVIS F275W exposure. Taking into account the raised natural background of this pseudo-CVZ visit, this requirement becomes satisfied for FLASH=10. APT has no knowledge of this raised natural background, hence issues a warning.</i></p>					
9	(1) JWST-NEP-TDF ACS/WFC, ACCUM, WFCENTER F435W	POS TARG 44.9,+3 64.900	Sequence 1-26 Non-Int in treasurehunt-epoch12of13 (05) Prime + Parallel Group 9-11 in Sequence 1-26 Non-Int in treasurehunt-epoch12of13 (05)	1245 Secs (1245 Secs) [==>]	[2]
<p><i>Comments: The specified POS_TARG values intentionally place the WFC3/UVIS and ACS/WFC instrument apertures off the coordinates of the target (i.e., the center of the JWST NEP Time-Domain Field) to their intended locations within an annulus surrounding the extant HST data.</i></p>					
10	(1) JWST-NEP-TDF ACS/WFC, ACCUM, WFCENTER F606W	POS TARG 44.9,+3 64.900	Sequence 1-26 Non-Int in treasurehunt-epoch12of13 (05) Prime + Parallel Group 9-11 in Sequence 1-26 Non-Int in treasurehunt-epoch12of13 (05)	1245 Secs (1245 Secs) [==>]	[2]
11	(WFC3UVI ANY S.im.1445613) WFC3/UVIS, ACCUM, UVIS F275W FLASH=9		Sequence 1-26 Non-Int in treasurehunt-epoch12of13 (05) Prime + Parallel Group 9-11 in Sequence 1-26 Non-Int in treasurehunt-epoch12of13 (05)	2714 Secs (2714 Secs) [==>]	[2]
<p><i>Comments: Following the June 4 2020 recommendations of J. Anderson (2020) "CURRENT CTE-MITIGATION RECOMMENDATIONS", we aim for a minimum background level of 20 e-/pix in each WFC3/UVIS F275W exposure. Taking into account the raised natural background of this pseudo-CVZ visit, this requirement becomes satisfied for FLASH=9. APT has no knowledge of this raised natural background, hence issues a warning.</i></p>					

Proposal 16793 - treasurehunt-epoch12of13 (05) - TREASUREHUNT: Hubble's UV-Visible treasury imaging of the JWST NEP Time-...

12	(1) JWST-NEP-TDF ACS/WFC, ACCUM, WFCENTER F606W	POS TARG +45.100 ,+364.900	Sequence 1-26 Non-Int in treasurehunt-epoch12of13 (05) Prime + Parallel Group 12-14 in Sequence 1-26 Non-Int in treasurehunt-epoch12of13 (05)	1253 Secs (1253 Secs) [==>]	[2]
<p><i>Comments: The specified POS_TARG values intentionally place the WFC3/UVIS and ACS/WFC instrument apertures off the coordinates of the target (i.e., the center of the JWST NEP Time-Domain Field) to their intended locations within an annulus surrounding the extant HST data.</i></p>					
13	(1) JWST-NEP-TDF ACS/WFC, ACCUM, WFCENTER F435W	POS TARG +45.100 ,+364.900	Sequence 1-26 Non-Int in treasurehunt-epoch12of13 (05) Prime + Parallel Group 12-14 in Sequence 1-26 Non-Int in treasurehunt-epoch12of13 (05)	1254 Secs (1254 Secs) [==>]	[2]
14	(WFC3UVI ANY S.im.1445613) WFC3/UVIS, ACCUM, UVIS F275W FLASH=9		Sequence 1-26 Non-Int in treasurehunt-epoch12of13 (05) Prime + Parallel Group 12-14 in Sequence 1-26 Non-Int in treasurehunt-epoch12of13 (05)	2731 Secs (2731 Secs) [==>]	[2]
<p><i>Comments: Following the June 4 2020 recommendations of J. Anderson (2020) "CURRENT CTE-MITIGATION RECOMMENDATIONS", we aim for a minimum background level of 20 e-/pix in each WFC3/UVIS F275W exposure. Taking into account the raised natural background of this pseudo-CVZ visit, this requirement becomes satisfied for FLASH=9. APT has no knowledge of this raised natural background, hence issues a warning.</i></p>					
15	(1) JWST-NEP-TDF ACS/WFC, ACCUM, WFCENTER F435W	POS TARG 44.8,+3 65.200	Sequence 1-26 Non-Int in treasurehunt-epoch12of13 (05) Prime + Parallel Group 15-17 in Sequence 1-26 Non-Int in treasurehunt-epoch12of13 (05)	1245 Secs (1245 Secs) [==>]	[3]
<p><i>Comments: The specified POS_TARG values intentionally place the WFC3/UVIS and ACS/WFC instrument apertures off the coordinates of the target (i.e., the center of the JWST NEP Time-Domain Field) to their intended locations within an annulus surrounding the extant HST data.</i></p>					
16	(1) JWST-NEP-TDF ACS/WFC, ACCUM, WFCENTER F606W	POS TARG 44.8,+3 65.200	Sequence 1-26 Non-Int in treasurehunt-epoch12of13 (05) Prime + Parallel Group 15-17 in Sequence 1-26 Non-Int in treasurehunt-epoch12of13 (05)	1245 Secs (1245 Secs) [==>]	[3]
17	(WFC3UVI ANY S.im.1445613) WFC3/UVIS, ACCUM, UVIS F275W FLASH=9		Sequence 1-26 Non-Int in treasurehunt-epoch12of13 (05) Prime + Parallel Group 15-17 in Sequence 1-26 Non-Int in treasurehunt-epoch12of13 (05)	2714 Secs (2714 Secs) [==>]	[3]
<p><i>Comments: Following the June 4 2020 recommendations of J. Anderson (2020) "CURRENT CTE-MITIGATION RECOMMENDATIONS", we aim for a minimum background level of 20 e-/pix in each WFC3/UVIS F275W exposure. Taking into account the raised natural background of this pseudo-CVZ visit, this requirement becomes satisfied for FLASH=9. APT has no knowledge of this raised natural background, hence issues a warning.</i></p>					

Proposal 16793 - treasurehunt-epoch12of13 (05) - TREASUREHUNT: Hubble's UV-Visible treasury imaging of the JWST NEP Time-...

18	(1) JWST-NEP-TDF ACS/WFC, ACCUM, WFCENTER F606W	POS TARG +45.000 ,+365.200	Sequence 1-26 Non-Int in treasurehunt-epoch12of13 (05) Prime + Parallel Group 18-20 in Sequence 1-26 Non-Int in treasurehunt-epoch12of13 (05)	1253 Secs (1253 Secs) [==>]	[3]
<p>Comments: The specified POS_TARG values intentionally place the WFC3/UVIS and ACS/WFC instrument apertures off the coordinates of the target (i.e., the center of the JWST NEP Time-Domain Field) to their intended locations within an annulus surrounding the extant HST data.</p>					
19	(1) JWST-NEP-TDF ACS/WFC, ACCUM, WFCENTER F435W	POS TARG +45.000 ,+365.200	Sequence 1-26 Non-Int in treasurehunt-epoch12of13 (05) Prime + Parallel Group 18-20 in Sequence 1-26 Non-Int in treasurehunt-epoch12of13 (05)	1254 Secs (1254 Secs) [==>]	[3]
20	(WFC3UVI ANY S.im.1445613) WFC3/UVIS, ACCUM, UVIS F275W FLASH=9		Sequence 1-26 Non-Int in treasurehunt-epoch12of13 (05) Prime + Parallel Group 18-20 in Sequence 1-26 Non-Int in treasurehunt-epoch12of13 (05)	2731 Secs (2731 Secs) [==>]	[3]
<p>Comments: Following the June 4 2020 recommendations of J. Anderson (2020) "CURRENT CTE-MITIGATION RECOMMENDATIONS", we aim for a minimum background level of 20 e-/pix in each WFC3/UVIS F275W exposure. Taking into account the raised natural background of this pseudo-CVZ visit, this requirement becomes satisfied for FLASH=9. APT has no knowledge of this raised natural background, hence issues a warning.</p>					
21	(1) JWST-NEP-TDF ACS/WFC, ACCUM, WFCENTER F435W	POS TARG 44.8,+365.000	Sequence 1-26 Non-Int in treasurehunt-epoch12of13 (05) Prime + Parallel Group 21-23 in Sequence 1-26 Non-Int in treasurehunt-epoch12of13 (05)	994 Secs (994 Secs) [==>]	[4]
<p>Comments: The specified POS_TARG values intentionally place the WFC3/UVIS and ACS/WFC instrument apertures off the coordinates of the target (i.e., the center of the JWST NEP Time-Domain Field) to their intended locations within an annulus surrounding the extant HST data.</p>					
22	(1) JWST-NEP-TDF ACS/WFC, ACCUM, WFCENTER F606W	POS TARG 44.8,+365.000	Sequence 1-26 Non-Int in treasurehunt-epoch12of13 (05) Prime + Parallel Group 21-23 in Sequence 1-26 Non-Int in treasurehunt-epoch12of13 (05)	994 Secs (994 Secs) [==>]	[4]
23	(WFC3UVI ANY S.im.1445644) WFC3/UVIS, ACCUM, UVIS F275W FLASH=12		Sequence 1-26 Non-Int in treasurehunt-epoch12of13 (05) Prime + Parallel Group 21-23 in Sequence 1-26 Non-Int in treasurehunt-epoch12of13 (05)	2212 Secs (2212 Secs) [==>]	[4]
<p>Comments: Following the June 4 2020 recommendations of J. Anderson (2020) "CURRENT CTE-MITIGATION RECOMMENDATIONS", we aim for a minimum background level of 20 e-/pix in each WFC3/UVIS F275W exposure. Taking into account the raised natural background of this pseudo-CVZ visit, this requirement becomes satisfied for FLASH=12.</p>					

Proposal 16793 - treasurehunt-epoch12of13 (05) - TREASUREHUNT: Hubble's UV-Visible treasury imaging of the JWST NEP Time-...

24	(1) JWST-NEP-TDF ACS/WFC, ACCUM, WFCENTER F606W	POS TARG +45.000 ,+365.000	Sequence 1-26 Non-Int in treasurehunt-epoch12of13 (05) Prime + Parallel Group 24-26 in Sequence 1-26 Non-Int in treasurehunt-epoch12of13 (05)	997 Secs (997 Secs)	[==>]	[4]		
<p><i>Comments: The specified POS_TARG values intentionally place the WFC3/UVIS and ACS/WFC instrument apertures off the coordinates of the target (i.e., the center of the JWST NEP Time-Domain Field) to their intended locations within an annulus surrounding the extant HST data.</i></p>								
25	(1) JWST-NEP-TDF ACS/WFC, ACCUM, WFCENTER F435W	POS TARG +45.000 ,+365.000	Sequence 1-26 Non-Int in treasurehunt-epoch12of13 (05) Prime + Parallel Group 24-26 in Sequence 1-26 Non-Int in treasurehunt-epoch12of13 (05)	997 Secs (997 Secs)	[==>]	[4]		
26	(WFC3UVI ANY S.im.144564 4)	WFC3/UVIS, ACCUM, UVIS	F275W	FLASH=12	Sequence 1-26 Non-Int in treasurehunt-epoch12of13 (05) Prime + Parallel Group 24-26 in Sequence 1-26 Non-Int in treasurehunt-epoch12of13 (05)	2198 Secs (2198 Secs)	[==>]	[4]
<p><i>Comments: Following the June 4 2020 recommendations of J. Anderson (2020) "CURRENT CTE-MITIGATION RECOMMENDATIONS", we aim for a minimum background level of 20 e-/pix in each WFC3/UVIS F275W exposure. Taking into account the raised natural background of this pseudo-CVZ visit, this requirement becomes satisfied for FLASH=12.</i></p>								

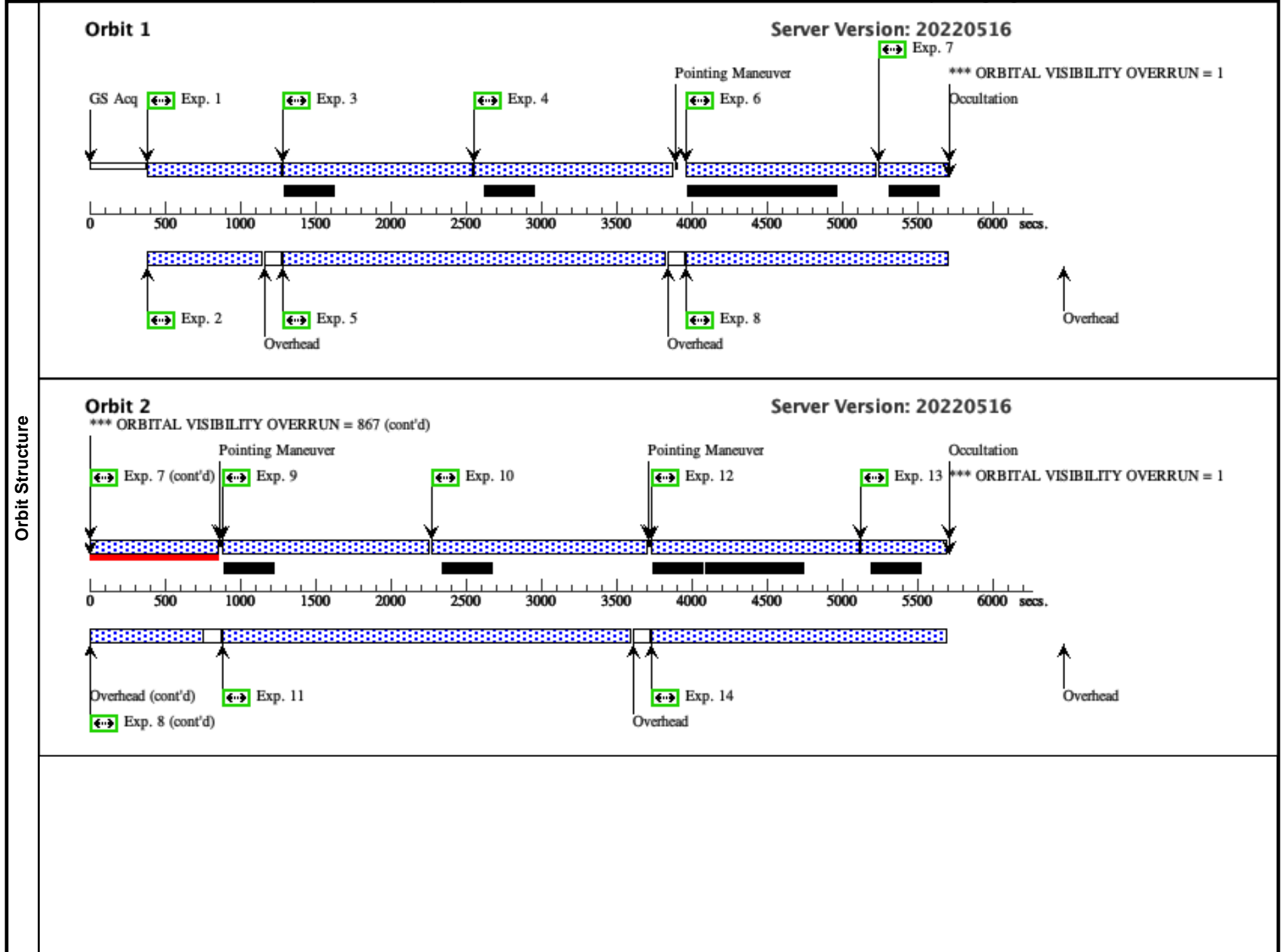

Orbit 3

Server Version: 20220516

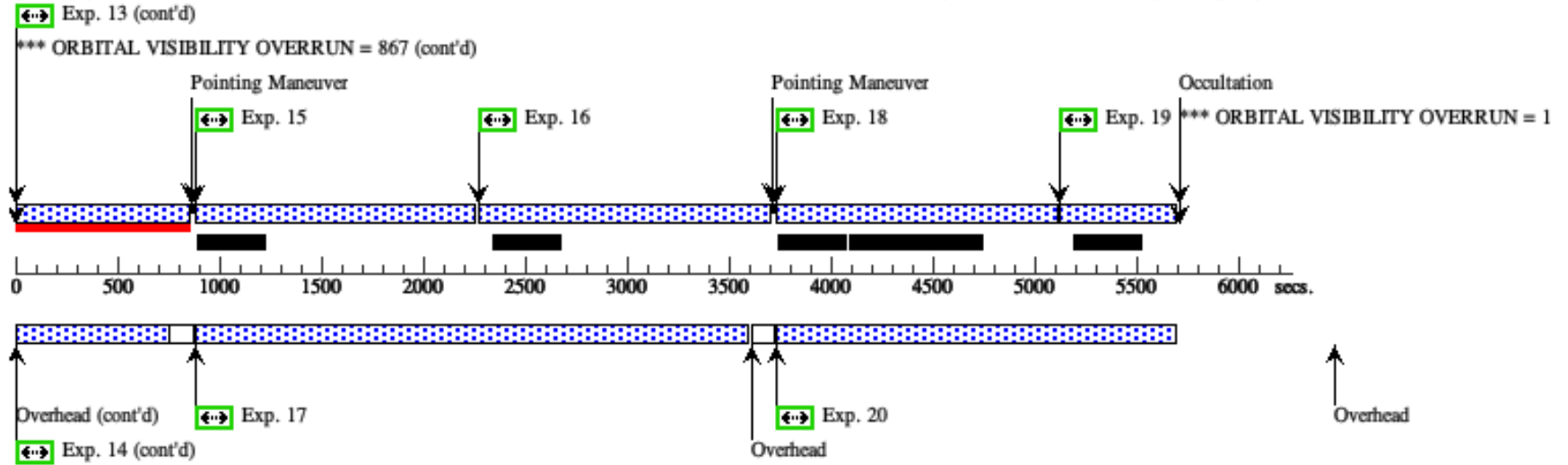

Orbit 4

Server Version: 20220516

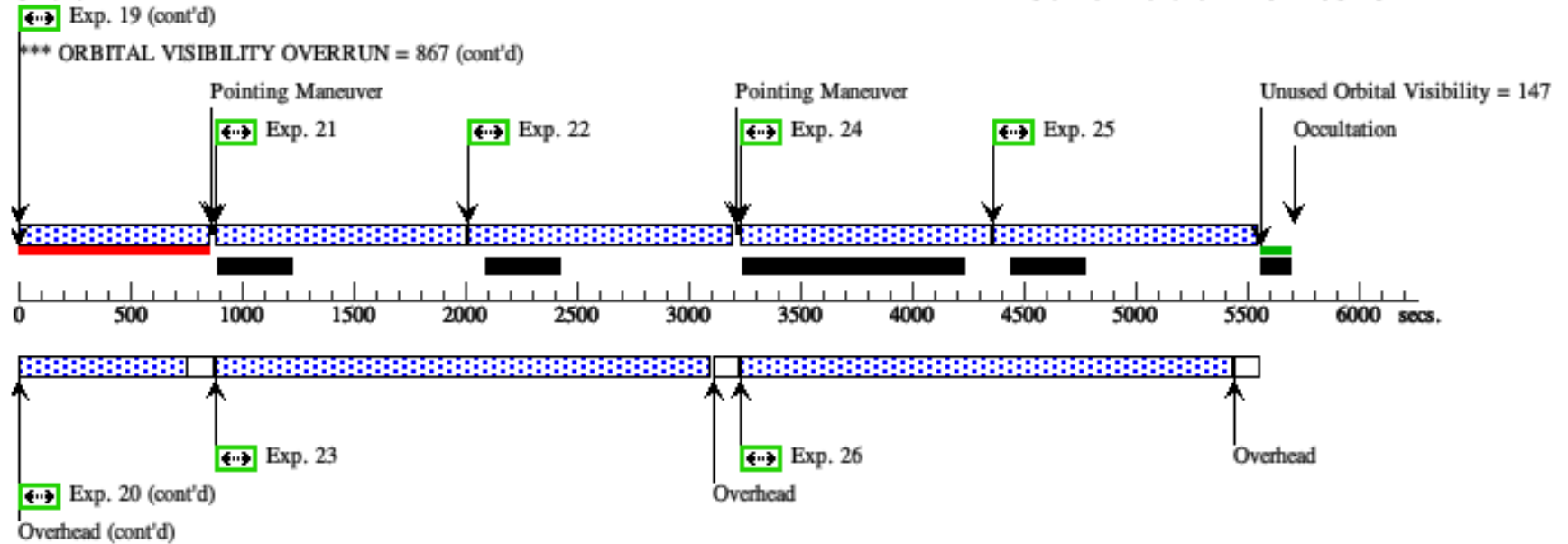

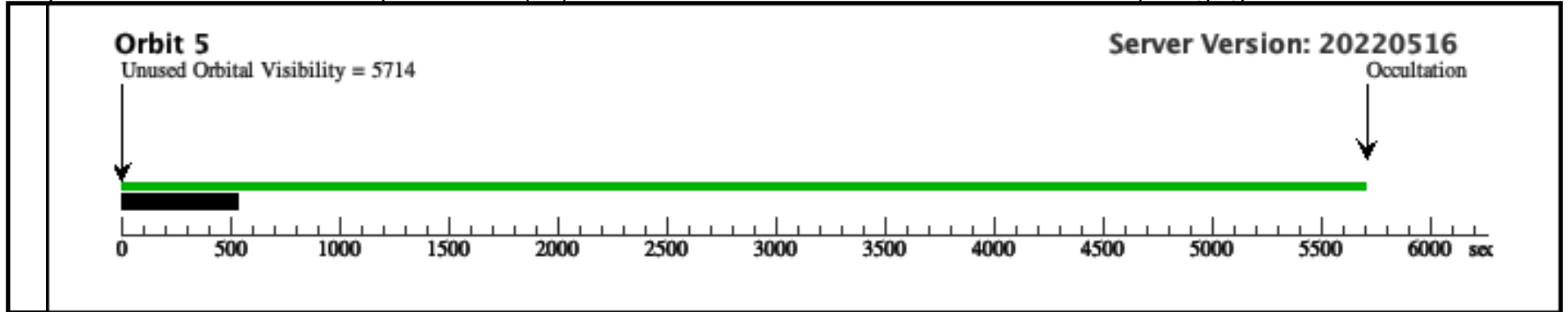

Proposal 16793 - treasurehunt-epoch13of13 (06) - TREASUREHUNT: Hubble's UV-Visible treasury imaging of the JWST NEP Time-...

Fixed Targets	#	Name	Target Coordinates	Targ. Coord. Corrections	Fluxes	Miscellaneous
	(1)	JWST-NEP-TDF	RA: 17 22 47.8960 (260.6995667d) Dec: +65 49 21.54 (65.82265d) Equinox: J2000		V=27.0+/-1.0	Reference Frame: ICRS
<p><i>Comments: The target field is centered on the extant HST observations of the JWST NEP Time-Domain Field of GO-15278. Allocated JWST GTO observations will provide both NIRCам imaging and NIRISS slitless spectroscopy in this field, which was defined to be the cleanest ~14' diameter area in JWST's northern continuous viewing zone, where JWST will conduct a deep extragalactic time-domain survey, with added utility for extreme outer solar system and near-Galactic time-domain science. The JWST NEP Time-Domain Field is developed as a *community field*, and has deep coverage accross the electromagnetic spectrum from X-ray through long-wave radio. The present Cycle 28+29 HST program will complete near-contiguous 3-filter coverage in the UV--Visible, targeting the annulus surrounding the extant HST observations of GO-15278. The present Phase-II APT specifies the Cycle 29 pointings within that annulus.</i></p> <p>Category=UNIDENTIFIED Description=[HIGH LATITUDE FIELD, INFRARED EMITTER, OPTICAL EMITTER, ULTRAVIOLET EMITTER]</p>						

Proposal 16793 - treasurehunt-epoch13of13 (06) - TREASUREHUNT: Hubble's UV-Visible treasury imaging of the JWST NEP Time...

#	Label (ETC Run)	Target	Config,Mode,Aperture	Spectral Els.	Opt. Params.	Special Reqs.	Groups	Exp. Time (Total)/[Actual Dur.]	Orbit
1		(1) JWST-NEP-TDF	ACS/WFC, ACCUM, WFCENTER	F435W		POS TARG 44.90,37 5.10	Sequence 1-26 Non-Int in treasurehunt-epoch13of13 (06) Prime + Parallel Group 1-2 in Sequence 1-26 Non-Int in treasurehunt-epoch13of13 (06)	860 Secs (860 Secs) [==>]	[1]
<p>Comments: The specified POS_TARG values intentionally place the WFC3/UVIS and ACS/WFC instrument apertures off the coordinates of the target (i.e., the center of the JWST NEP Time-Domain Field) to their intended locations within an annulus surrounding the extant HST data.</p>									
2	(WFC3UVIS.im.1445613)	ANY	WFC3/UVIS, ACCUM, UVIS	F275W	FLASH=12		Sequence 1-26 Non-Int in treasurehunt-epoch13of13 (06) Prime + Parallel Group 1-2 in Sequence 1-26 Non-Int in treasurehunt-epoch13of13 (06)	913 Secs (913 Secs) [==>]	[1]
<p>Comments: Following the June 4 2020 recommendations of J. Anderson (2020) "CURRENT CTE-MITIGATION RECOMMENDATIONS", we aim for a minimum background level of 20 e-/pix in each WFC3/UVIS F275W exposure. Taking into account the raised natural background of this pseudo-CVZ visit, the WFC3/UVIS ETC shows that this requirement becomes satisfied for FLASH=11. The APT Phase-II diagnostics seem to still test the older (now superseded) recommendation of a minimum of only 12 e-/pix, and therefore result in a warning that the specified postflash may be too high.</p>									
3		(1) JWST-NEP-TDF	ACS/WFC, ACCUM, WFCENTER	F435W		POS TARG 44.90,37 5.10	Sequence 1-26 Non-Int in treasurehunt-epoch13of13 (06) Prime + Parallel Group 3-5 in Sequence 1-26 Non-Int in treasurehunt-epoch13of13 (06)	1136 Secs (1136 Secs) [==>]	[1]
<p>Comments: The specified POS_TARG values intentionally place the WFC3/UVIS and ACS/WFC instrument apertures off the coordinates of the target (i.e., the center of the JWST NEP Time-Domain Field) to their intended locations within an annulus surrounding the extant HST data.</p>									
4		(1) JWST-NEP-TDF	ACS/WFC, ACCUM, WFCENTER	F606W		POS TARG 44.90,37 5.10	Sequence 1-26 Non-Int in treasurehunt-epoch13of13 (06) Prime + Parallel Group 3-5 in Sequence 1-26 Non-Int in treasurehunt-epoch13of13 (06)	1136 Secs (1136 Secs) [==>]	[1]
5	(WFC3UVIS.im.1445613)	ANY	WFC3/UVIS, ACCUM, UVIS	F275W	FLASH=10		Sequence 1-26 Non-Int in treasurehunt-epoch13of13 (06) Prime + Parallel Group 3-5 in Sequence 1-26 Non-Int in treasurehunt-epoch13of13 (06)	2545 Secs (2545 Secs) [==>]	[1]
<p>Comments: Following the June 4 2020 recommendations of J. Anderson (2020) "CURRENT CTE-MITIGATION RECOMMENDATIONS", we aim for a minimum background level of 20 e-/pix in each WFC3/UVIS F275W exposure. Taking into account the raised natural background of this pseudo-CVZ visit, the WFC3/UVIS ETC shows that this requirement becomes satisfied for FLASH=11. The APT Phase-II diagnostics seem to still test the older (now superseded) recommendation of a minimum of only 12 e-/pix, and therefore result in a warning that the specified postflash may be too high.</p>									

Proposal 16793 - treasurehunt-epoch13of13 (06) - TREASUREHUNT: Hubble's UV-Visible treasury imaging of the JWST NEP Time...

6	(1) JWST-NEP-TDF ACS/WFC, ACCUM, WFCENTER F606W	POS TARG 45.10,37 5.10	Sequence 1-26 Non-Int in treasurehunt-epoch13of13 (06) Prime + Parallel Group 6-8 in Sequence 1-26 Non-Int in treasurehunt-epoch13of13 (06)	1140 Secs (1140 Secs) [==>]	[1]
<p>Comments: The specified POS_TARG values intentionally place the WFC3/UVIS and ACS/WFC instrument apertures off the coordinates of the target (i.e., the center of the JWST NEP Time-Domain Field) to their intended locations within an annulus surrounding the extant HST data.</p>					
7	(1) JWST-NEP-TDF ACS/WFC, ACCUM, WFCENTER F435W	POS TARG 45.10,37 5.10	Sequence 1-26 Non-Int in treasurehunt-epoch13of13 (06) Prime + Parallel Group 6-8 in Sequence 1-26 Non-Int in treasurehunt-epoch13of13 (06)	1140 Secs (1140 Secs) [==>]	[1]
8	(WFC3UVI ANY S.im.1445613) WFC3/UVIS, ACCUM, UVIS F275W FLASH=10		Sequence 1-26 Non-Int in treasurehunt-epoch13of13 (06) Prime + Parallel Group 6-8 in Sequence 1-26 Non-Int in treasurehunt-epoch13of13 (06)	2504 Secs (2504 Secs) [==>]	[1]
<p>Comments: Following the June 4 2020 recommendations of J. Anderson (2020) "CURRENT CTE-MITIGATION RECOMMENDATIONS", we aim for a minimum background level of 20 e-/pix in each WFC3/UVIS F275W exposure. Taking into account the raised natural background of this pseudo-CVZ visit, the WFC3/UVIS ETC shows that this requirement becomes satisfied for FLASH=11. The APT Phase-II diagnostics seem to still test the older (now superseded) recommendation of a minimum of only 12 e-/pix, and therefore result in a warning that the specified postflash may be too high.</p>					
9	(1) JWST-NEP-TDF ACS/WFC, ACCUM, WFCENTER F435W	POS TARG 44.90,37 4.90	Sequence 1-26 Non-Int in treasurehunt-epoch13of13 (06) Prime + Parallel Group 9-11 in Sequence 1-26 Non-Int in treasurehunt-epoch13of13 (06)	1245 Secs (1245 Secs) [==>]	[2]
<p>Comments: The specified POS_TARG values intentionally place the WFC3/UVIS and ACS/WFC instrument apertures off the coordinates of the target (i.e., the center of the JWST NEP Time-Domain Field) to their intended locations within an annulus surrounding the extant HST data.</p>					
10	(1) JWST-NEP-TDF ACS/WFC, ACCUM, WFCENTER F606W	POS TARG 44.90,37 4.90	Sequence 1-26 Non-Int in treasurehunt-epoch13of13 (06) Prime + Parallel Group 9-11 in Sequence 1-26 Non-Int in treasurehunt-epoch13of13 (06)	1245 Secs (1245 Secs) [==>]	[2]
11	(WFC3UVI ANY S.im.1445613) WFC3/UVIS, ACCUM, UVIS F275W FLASH=9		Sequence 1-26 Non-Int in treasurehunt-epoch13of13 (06) Prime + Parallel Group 9-11 in Sequence 1-26 Non-Int in treasurehunt-epoch13of13 (06)	2714 Secs (2714 Secs) [==>]	[2]
<p>Comments: Following the June 4 2020 recommendations of J. Anderson (2020) "CURRENT CTE-MITIGATION RECOMMENDATIONS", we aim for a minimum background level of 20 e-/pix in each WFC3/UVIS F275W exposure. Taking into account the raised natural background of this pseudo-CVZ visit, the WFC3/UVIS ETC shows that this requirement becomes satisfied for FLASH=10. The APT Phase-II diagnostics seem to still test the older (now superseded) recommendation of a minimum of only 12 e-/pix, and therefore result in a warning that the specified postflash may be too high.</p>					

Proposal 16793 - treasurehunt-epoch13of13 (06) - TREASUREHUNT: Hubble's UV-Visible treasury imaging of the JWST NEP Time...

12	(1) JWST-NEP-TDF ACS/WFC, ACCUM, WFCENTER F606W	POS TARG 45.10,37 4.90	Sequence 1-26 Non-Int in treasurehunt-epoch13of13 (06) Prime + Parallel Group 12-14 in Sequence 1-26 Non-Int in treasurehunt-epoch13of13 (06)	1253 Secs (1253 Secs) [==>]	[2]
<p><i>Comments: The specified POS_TARG values intentionally place the WFC3/UVIS and ACS/WFC instrument apertures off the coordinates of the target (i.e., the center of the JWST NEP Time-Domain Field) to their intended locations within an annulus surrounding the extant HST data.</i></p>					
13	(1) JWST-NEP-TDF ACS/WFC, ACCUM, WFCENTER F435W	POS TARG 45.10,37 4.90	Sequence 1-26 Non-Int in treasurehunt-epoch13of13 (06) Prime + Parallel Group 12-14 in Sequence 1-26 Non-Int in treasurehunt-epoch13of13 (06)	1254 Secs (1254 Secs) [==>]	[2]
14	(WFC3UVI ANY S.im.1445613) WFC3/UVIS, ACCUM, UVIS F275W FLASH=9		Sequence 1-26 Non-Int in treasurehunt-epoch13of13 (06) Prime + Parallel Group 12-14 in Sequence 1-26 Non-Int in treasurehunt-epoch13of13 (06)	2731 Secs (2731 Secs) [==>]	[2]
<p><i>Comments: Following the June 4 2020 recommendations of J. Anderson (2020) "CURRENT CTE-MITIGATION RECOMMENDATIONS", we aim for a minimum background level of 20 e-/pix in each WFC3/UVIS F275W exposure. Taking into account the raised natural background of this pseudo-CVZ visit, the WFC3/UVIS ETC shows that this requirement becomes satisfied for FLASH=10. The APT Phase-II diagnostics seem to still test the older (now superseded) recommendation of a minimum of only 12 e-/pix, and therefore result in a warning that the specified postflash may be too high.</i></p>					
15	(1) JWST-NEP-TDF ACS/WFC, ACCUM, WFCENTER F435W	POS TARG 44.80,37 5.20	Sequence 1-26 Non-Int in treasurehunt-epoch13of13 (06) Prime + Parallel Group 15-17 in Sequence 1-26 Non-Int in treasurehunt-epoch13of13 (06)	1245 Secs (1245 Secs) [==>]	[3]
<p><i>Comments: The specified POS_TARG values intentionally place the WFC3/UVIS and ACS/WFC instrument apertures off the coordinates of the target (i.e., the center of the JWST NEP Time-Domain Field) to their intended locations within an annulus surrounding the extant HST data.</i></p>					
16	(1) JWST-NEP-TDF ACS/WFC, ACCUM, WFCENTER F606W	POS TARG 44.80,37 5.20	Sequence 1-26 Non-Int in treasurehunt-epoch13of13 (06) Prime + Parallel Group 15-17 in Sequence 1-26 Non-Int in treasurehunt-epoch13of13 (06)	1245 Secs (1245 Secs) [==>]	[3]
17	(WFC3UVI ANY S.im.1445613) WFC3/UVIS, ACCUM, UVIS F275W FLASH=9		Sequence 1-26 Non-Int in treasurehunt-epoch13of13 (06) Prime + Parallel Group 15-17 in Sequence 1-26 Non-Int in treasurehunt-epoch13of13 (06)	2714 Secs (2714 Secs) [==>]	[3]
<p><i>Comments: Following the June 4 2020 recommendations of J. Anderson (2020) "CURRENT CTE-MITIGATION RECOMMENDATIONS", we aim for a minimum background level of 20 e-/pix in each WFC3/UVIS F275W exposure. Taking into account the raised natural background of this pseudo-CVZ visit, the WFC3/UVIS ETC shows that this requirement becomes satisfied for FLASH=10. The APT Phase-II diagnostics seem to still test the older (now superseded) recommendation of a minimum of only 12 e-/pix, and therefore result in a warning that the specified postflash may be too high.</i></p>					

Proposal 16793 - treasurehunt-epoch13of13 (06) - TREASUREHUNT: Hubble's UV-Visible treasury imaging of the JWST NEP Time...

18	(1) JWST-NEP-TDF ACS/WFC, ACCUM, WFCENTER F606W	POS TARG 45.00,37 5.20	Sequence 1-26 Non-Int in treasurehunt-epoch13of13 (06) Prime + Parallel Group 18-20 in Sequence 1-26 Non-Int in treasurehunt-epoch13of13 (06)	1253 Secs (1253 Secs) [==>]	[3]
<p><i>Comments: The specified POS_TARG values intentionally place the WFC3/UVIS and ACS/WFC instrument apertures off the coordinates of the target (i.e., the center of the JWST NEP Time-Domain Field) to their intended locations within an annulus surrounding the extant HST data.</i></p>					
19	(1) JWST-NEP-TDF ACS/WFC, ACCUM, WFCENTER F435W	POS TARG 45.00,37 5.20	Sequence 1-26 Non-Int in treasurehunt-epoch13of13 (06) Prime + Parallel Group 18-20 in Sequence 1-26 Non-Int in treasurehunt-epoch13of13 (06)	1254 Secs (1254 Secs) [==>]	[3]
20	(WFC3UVI ANY S.im.1445613) WFC3/UVIS, ACCUM, UVIS F275W FLASH=9		Sequence 1-26 Non-Int in treasurehunt-epoch13of13 (06) Prime + Parallel Group 18-20 in Sequence 1-26 Non-Int in treasurehunt-epoch13of13 (06)	2731 Secs (2731 Secs) [==>]	[3]
<p><i>Comments: Following the June 4 2020 recommendations of J. Anderson (2020) "CURRENT CTE-MITIGATION RECOMMENDATIONS", we aim for a minimum background level of 20 e-/pix in each WFC3/UVIS F275W exposure. Taking into account the raised natural background of this pseudo-CVZ visit, the WFC3/UVIS ETC shows that this requirement becomes satisfied for FLASH=10. The APT Phase-II diagnostics seem to still test the older (now superseded) recommendation of a minimum of only 12 e-/pix, and therefore result in a warning that the specified postflash may be too high.</i></p>					
21	(1) JWST-NEP-TDF ACS/WFC, ACCUM, WFCENTER F435W	POS TARG 44.80,37 5.00	Sequence 1-26 Non-Int in treasurehunt-epoch13of13 (06) Prime + Parallel Group 21-23 in Sequence 1-26 Non-Int in treasurehunt-epoch13of13 (06)	994 Secs (994 Secs) [==>]	[4]
<p><i>Comments: The specified POS_TARG values intentionally place the WFC3/UVIS and ACS/WFC instrument apertures off the coordinates of the target (i.e., the center of the JWST NEP Time-Domain Field) to their intended locations within an annulus surrounding the extant HST data.</i></p>					
22	(1) JWST-NEP-TDF ACS/WFC, ACCUM, WFCENTER F606W	POS TARG 44.80,37 5.00	Sequence 1-26 Non-Int in treasurehunt-epoch13of13 (06) Prime + Parallel Group 21-23 in Sequence 1-26 Non-Int in treasurehunt-epoch13of13 (06)	994 Secs (994 Secs) [==>]	[4]
23	(WFC3UVI ANY S.im.1445644) WFC3/UVIS, ACCUM, UVIS F275W FLASH=11		Sequence 1-26 Non-Int in treasurehunt-epoch13of13 (06) Prime + Parallel Group 21-23 in Sequence 1-26 Non-Int in treasurehunt-epoch13of13 (06)	2212 Secs (2212 Secs) [==>]	[4]
<p><i>Comments: Following the June 4 2020 recommendations of J. Anderson (2020) "CURRENT CTE-MITIGATION RECOMMENDATIONS", we aim for a minimum background level of 20 e-/pix in each WFC3/UVIS F275W exposure. Taking into account the raised natural background of this pseudo-CVZ visit, the WFC3/UVIS ETC shows that this requirement becomes satisfied for FLASH=12. The APT Phase-II diagnostics seem to still test the older (now superseded) recommendation of a minimum of only 12 e-/pix, and therefore result in a warning that the specified postflash may be too high.</i></p>					

Proposal 16793 - treasurehunt-epoch13of13 (06) - TREASUREHUNT: Hubble's UV-Visible treasury imaging of the JWST NEP Time...

24	(1) JWST-NEP-TDF ACS/WFC, ACCUM, WFCENTER F606W	POS TARG 45.00,37 5.00	Sequence 1-26 Non-Int in treasurehunt-epoch13of13 (06) Prime + Parallel Group 24-26 in Sequence 1-26 Non-Int in treasurehunt-epoch13of13 (06)	997 Secs (997 Secs)	[==>]	[4]		
<p><i>Comments: The specified POS_TARG values intentionally place the WFC3/UVIS and ACS/WFC instrument apertures off the coordinates of the target (i.e., the center of the JWST NEP Time-Domain Field) to their intended locations within an annulus surrounding the extant HST data.</i></p>								
25	(1) JWST-NEP-TDF ACS/WFC, ACCUM, WFCENTER F435W	POS TARG 45.00,37 5.00	Sequence 1-26 Non-Int in treasurehunt-epoch13of13 (06) Prime + Parallel Group 24-26 in Sequence 1-26 Non-Int in treasurehunt-epoch13of13 (06)	997 Secs (997 Secs)	[==>]	[4]		
26	(WFC3UVI ANY S.im.144564 4)	WFC3/UVIS, ACCUM, UVIS	F275W	FLASH=11	Sequence 1-26 Non-Int in treasurehunt-epoch13of13 (06) Prime + Parallel Group 24-26 in Sequence 1-26 Non-Int in treasurehunt-epoch13of13 (06)	2198 Secs (2198 Secs)	[==>]	[4]
<p><i>Comments: Following the June 4 2020 recommendations of J. Anderson (2020) "CURRENT CTE-MITIGATION RECOMMENDATIONS", we aim for a minimum background level of 20 e-/pix in each WFC3/UVIS F275W exposure. Taking into account the raised natural background of this pseudo-CVZ visit, the WFC3/UVIS ETC shows that this requirement becomes satisfied for FLASH=12. The APT Phase-II diagnostics seem to still test the older (now superseded) recommendation of a minimum of only 12 e-/pix, and therefore result in a warning that the specified postflash may be too high.</i></p>								

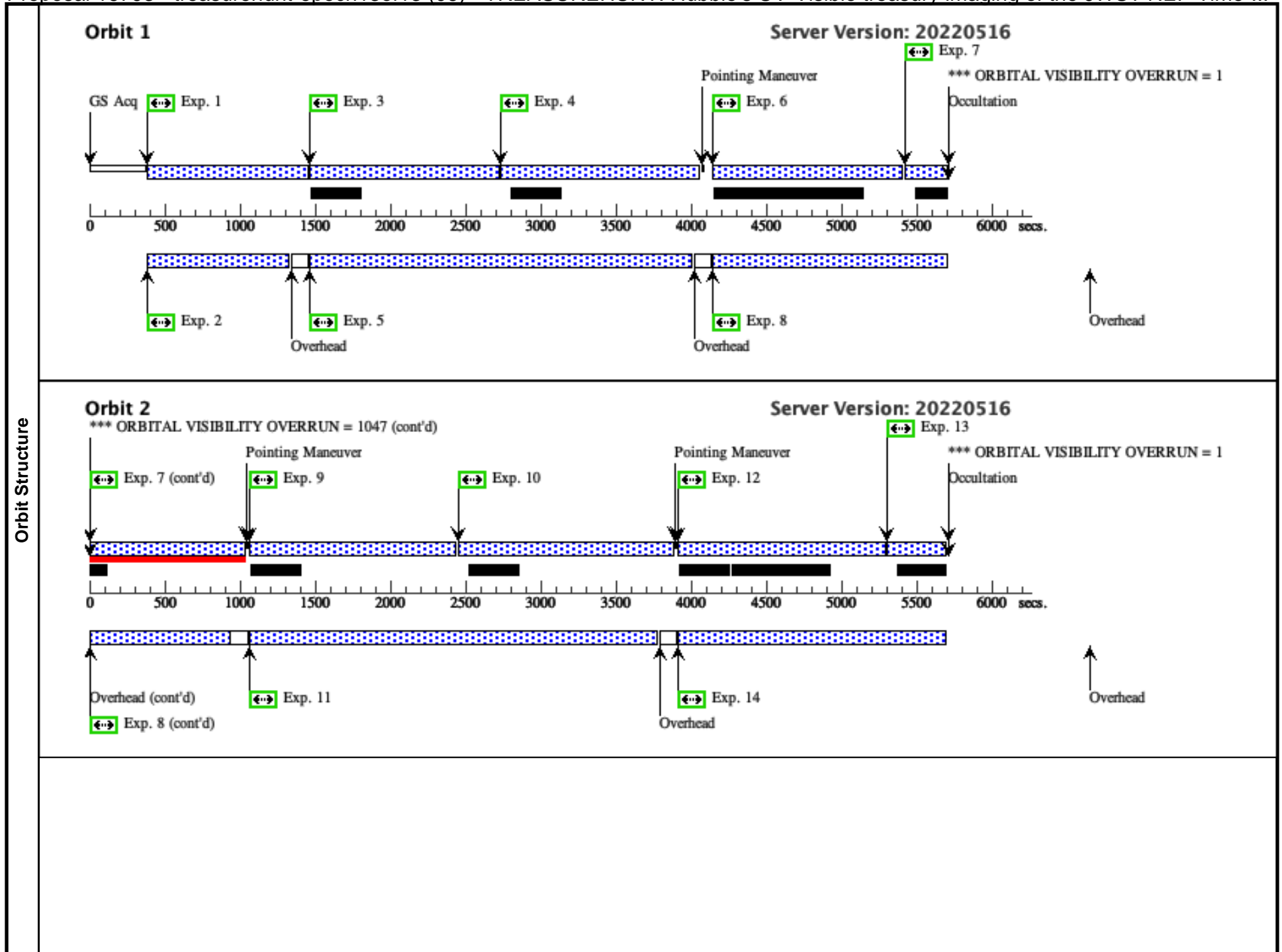

Orbit 3

Server Version: 20220516

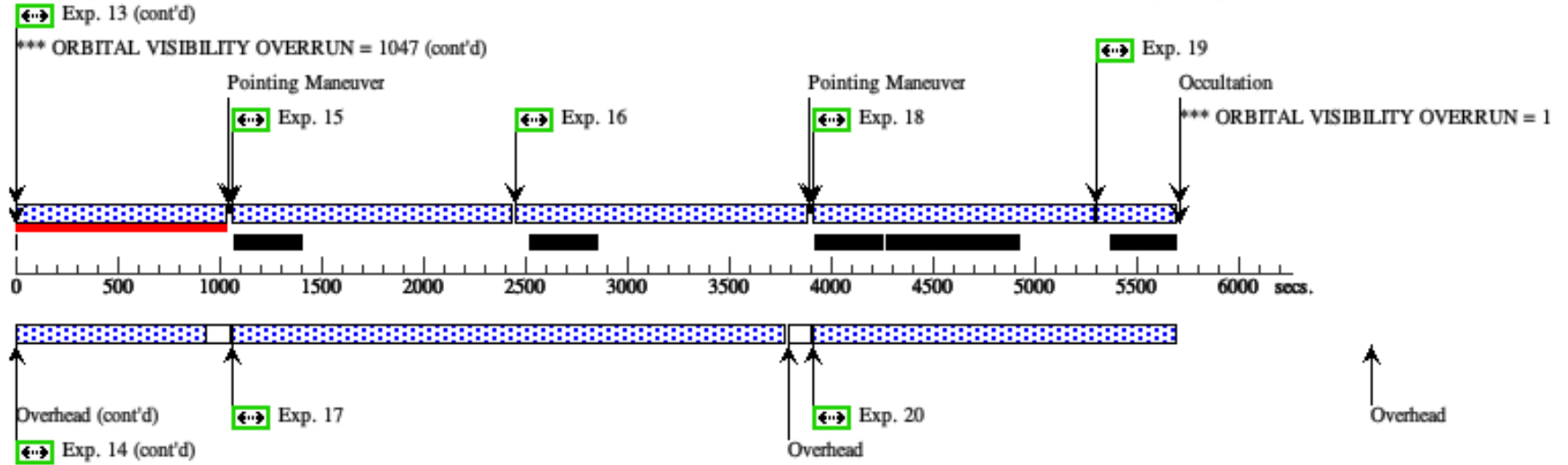

Orbit 4

Server Version: 20220516

