



# 17709 - Measuring Lyman-alpha Propagation in Planet-Forming Circumstellar Disks

Cycle: 32, Proposal Category: GO  
(Availability Mode: SUPPORTED)

## INVESTIGATORS

<i>Name</i>	<i>Institution</i>
<b>Dr. Nicole Arulanantham (PI) (Contact)</b>	<b>Schmidt Sciences</b>
Dr. Gregory J. Herczeg (CoI)	Peking University
Dr. Seok-Jun Chang (CoI) (ESA Member)	Max Planck Institute for Astrophysics
Dr. Max Gronke (CoI) (ESA Member)	Max Planck Institute for Astrophysics
Dr. Edwin Anthony Bergin (CoI)	University of Michigan
Dr. Jenny Calahan (CoI)	Smithsonian Institution Astrophysical Observatory

## VISITS

<i>Visit</i>	<i>Targets used in Visit</i>	<i>Configurations used in Visit</i>	<i>Orbits Used</i>	<i>Last Orbit Planner Run</i>	<i>OP Current with Visit?</i>
01	(1) HD-169142	STIS/CCD STIS/FUV-MAMA	4	18-Mar-2025 14:00:12.0	yes
02	(2) CPD-36-6759	STIS/CCD STIS/FUV-MAMA	3	18-Mar-2025 14:00:13.0	yes
03	(3) V-AB-AUR	STIS/CCD STIS/FUV-MAMA	3	18-Mar-2025 14:00:14.0	yes
04	(4) HD-163296	STIS/CCD STIS/FUV-MAMA	4	18-Mar-2025 14:00:15.0	yes

<i>Visit</i>	<i>Targets used in Visit</i>	<i>Configurations used in Visit</i>	<i>Orbits Used</i>	<i>Last Orbit Planner Run</i>	<i>OP Current with Visit?</i>
05	(5) V-T-CHA	STIS/CCD STIS/FUV-MAMA	5	18-Mar-2025 14:00:16.0	yes
09	(5) V-T-CHA	STIS/CCD STIS/FUV-MAMA	5	18-Mar-2025 14:00:17.0	yes
11	(5) V-T-CHA	STIS/CCD STIS/FUV-MAMA	2	18-Mar-2025 14:00:18.0	yes
08	(6) 2MASS-J04202144+2813491	STIS/CCD STIS/FUV-MAMA	5	18-Mar-2025 14:00:19.0	yes
10	(6) 2MASS-J04202144+2813491	STIS/CCD STIS/FUV-MAMA	5	18-Mar-2025 14:00:20.0	yes
12	(6) 2MASS-J04202144+2813491	STIS/CCD STIS/FUV-MAMA	2	18-Mar-2025 14:00:21.0	yes

38 Total Orbits Used

## **ABSTRACT**

Lyman-alpha emission makes up ~88% of the total FUV flux irradiating the circumstellar gas disks surrounding young stellar objects (YSOs). Radio and infrared observations along with advanced physical-chemical models indicate that the FUV radiation fields play a critical role in regulating the abundances and spatial distributions of water and organic molecules in disk regions where planet formation is ongoing. We propose to use the G140M mode on STIS to spectrally image resonantly scattered Lyman-alpha in a sample of six systems. The spatial coverage provided by this novel dataset, combined with 3-D radiative transfer models, will allow us to:

- 1) Measure the radial propagation of Lyman-alpha photons through the disks and winds;
- 2) Isolate the contribution of scattered flux from the disks alone, to measure the total radiation available to catalyze photochemistry; and
- 3) Constrain the spatial extents and opening angles of stellar and/or disk winds, which contribute the largest component of scattered flux.

This technique has so far only been applied to TW Hya, a face-on disk with three prominent gaps in its dust continuum emission. The targets in our sample span disk inclinations from 20-88 degrees and have dust gaps, spiral arms, and dust clumps and traps, allowing us to further explore the propagation of Lyman-alpha photons in asymmetric and dust-free disk environments. These results will provide new UV information that is required to analyze increasingly deep, spatially resolved data from ALMA and ongoing observations of warm molecular gas with JWST.

### **OBSERVING DESCRIPTION**

We will use the 0.2"x52" slit on STIS to construct line images of Lyman-alpha emission from a sample of six YSOs with circumstellar disks: HD 169142, HD 135344B, AB Aur, HD 163296, T Cha, and 2MASS J04202144+2813491. We will use the G140M grating centered at 1222 Angstroms to yield  $R \sim 10,000$  spectra from 1194-1249 Angstroms for all six of our targets. For the four disks with archival long-slit G140M spectra, the observations should be acquired at seven steps ( $\pm 0.6''$  in  $0.2''$  intervals) across each disk, allowing us to trace the propagation of scattered photons through the disk and constrain the vertical extent of the dense wind. For the remaining two disks, which are more inclined, the central position should be omitted due to the high extinction along the line-of-sight through the disk midplane. Each target will be acquired with the F28x500II filter at 5005 Angstroms, and an acquisition peak-up will be performed with the 0.05"x52" slit to ensure that the system is properly centered. Our science goals require  $S/N \sim 5$  in the Lyman-alpha line wings observed off source, following PSF subtraction based on the N V and Si III emission lines.

Proposal 17709 - HD 169142 (01) - Measuring Lyman-alpha Propagation in Planet-Forming Circumstellar Disks

Tue Mar 18 18:00:21 GMT 2025

<b>Visit</b>	<b>Proposal 17709, HD 169142 (01), implementation</b> <b>Diagnostic Status: No Diagnostics</b> Scientific Instruments: STIS/CCD, STIS/FUV-MAMA Special Requirements: (none) <i>Comments: HD 169142 visit. Acquisition followed by peak-up followed by series of seven offset science exposures from -0.6" to 0.6" in 0.2" increments.</i>									
	<b>Patterns</b>	<b>#</b>	<b>Primary Pattern</b>				<b>Secondary Pattern</b>			<b>Exposures</b>
(1)		Pattern Type=STIS-PERP-TO-SLIT	Coordinate Frame=POS-TARG						(2)	
		Purpose=DITHER	Pattern Orientation=0.0							
		Number Of Points=7	Angle Between Sides=							
		Point Spacing=0.2	Center Pattern=true							
		Line Spacing=								
<b>Fixed Targets</b>	<b>#</b>	<b>Name</b>	<b>Target Coordinates</b>	<b>Targ. Coord. Corrections</b>		<b>Fluxes</b>	<b>Miscellaneous</b>			
	(1)	HD-169142	RA: 18 24 29.7800 (276.1240833d) Dec: -29 46 49.33 (-29.78037d) Equinox: J2000	Proper Motion RA: -2.335 mas/yr Proper Motion Dec: -37.878999955864856 mas/yr Parallax: 0.0087053" Epoch of Position: 2000		V=8.16	Reference Frame: ICRS			
	<i>Comments: This object was generated by the targetselector and retrieved from the SIMBAD database.</i> <i>SIMBAD listed proper motion for this target. When retrieving targets with PM from SIMBAD, APT requests the coordinates be calculated with an epoch of the year 2000. Do not modify this epoch. Always review coordinates using the Target Confirmation tool, which graphically displays the PM.</i> Category=STAR Description=[HERBIG AE/BE, PROTOPLANETARY DISK]									
<b>Exposures</b>	<b>#</b>	<b>Label (ETC Run)</b>	<b>Target</b>	<b>Config,Mode,Aperture</b>	<b>Spectral Els.</b>	<b>Opt. Params.</b>	<b>Special Reqs.</b>	<b>Groups</b>	<b>Exp. Time (Total)/[Actual Dur.]</b>	<b>Orbit</b>
	1	HD 169142 Target Acquisition	(1) HD-169142	STIS/CCD, ACQ, F28X500II	MIRROR				5.0 Secs (5 Secs) [==>]	[1]
	2	(STIS.sp.19 19558)	(1) HD-169142	STIS/FUV-MAMA, ACCUM, 52X0.2	G140M 1222 A			Pattern 1, Exps 2-2 in HD 169142 (01) (1)	1519 Secs (9012 Secs) [==>2047.0 Secs (Pattern 1)] [==>1519.0 Secs (Pattern 2)] [==>816.0 Secs (Pattern 3)] [==>1519.0 Secs (Pattern 4)] [==>796.0 Secs (Pattern 5)] [==>1519.0 Secs (Pattern 6)] [==>796.0 Secs (Pattern 7)]	[1] [2] [3] [4]

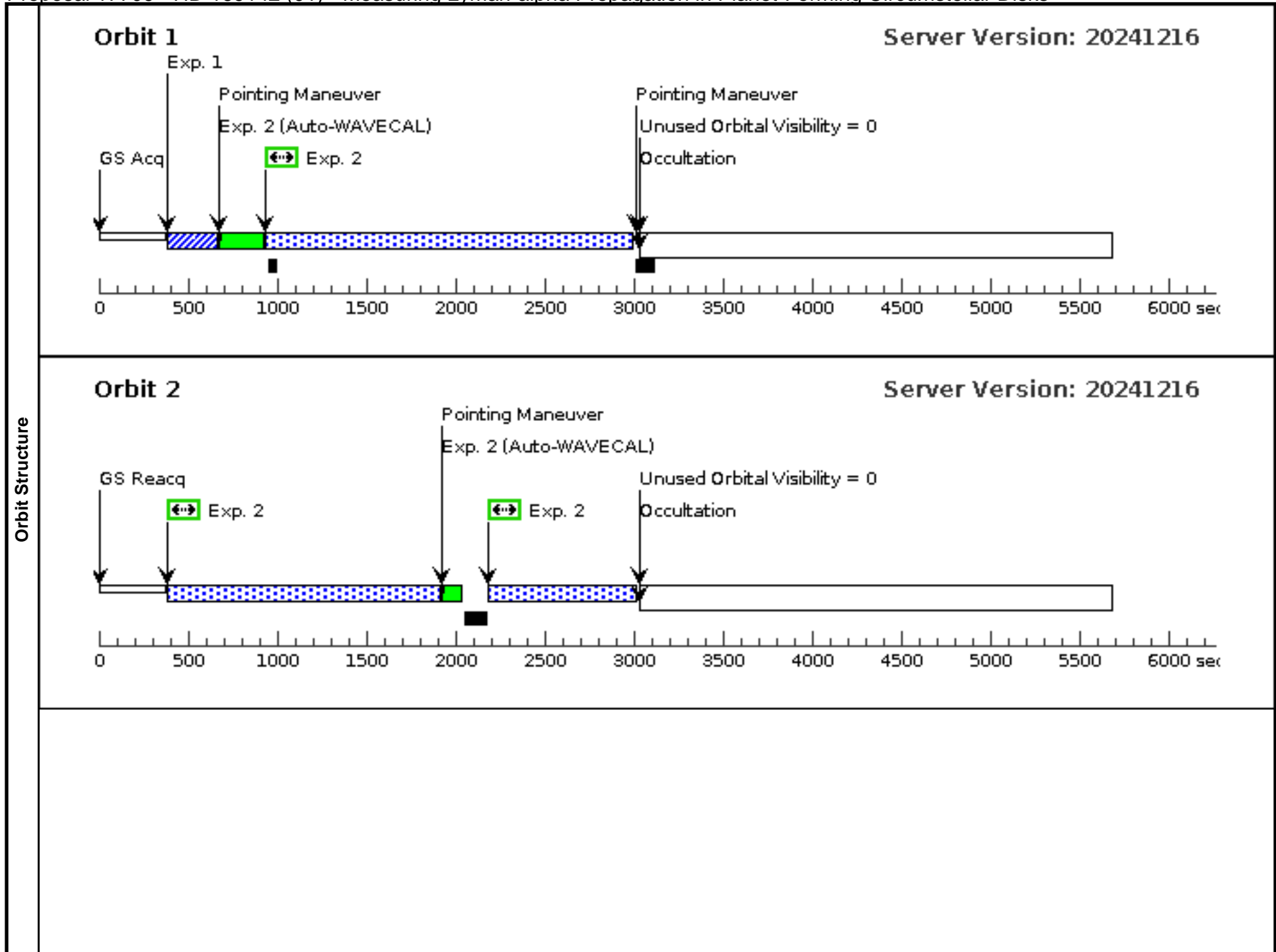

### Orbit 3

Server Version: 20241216

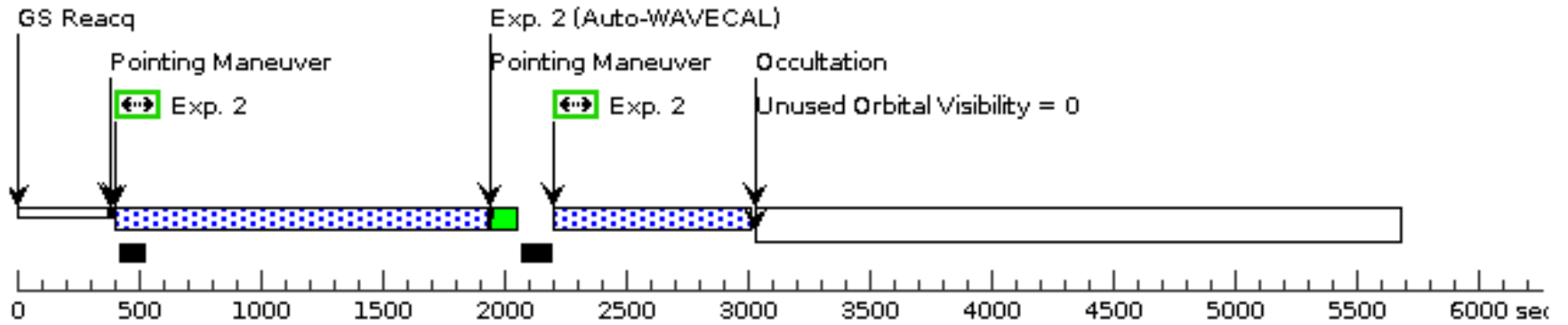

### Orbit 4

Server Version: 20241216

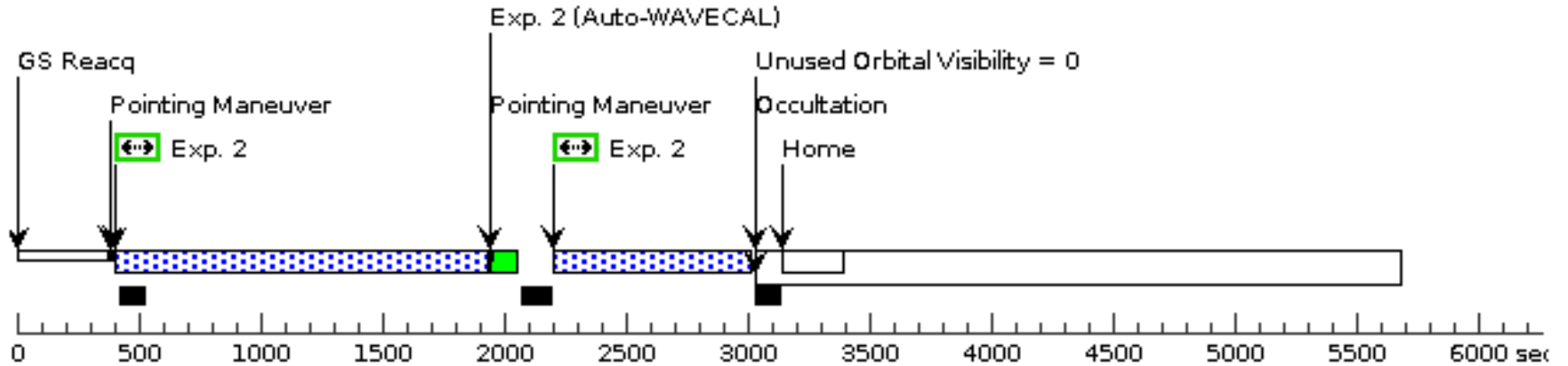

Proposal 17709 - HD 135344B (02) - Measuring Lyman-alpha Propagation in Planet-Forming Circumstellar Disks

Tue Mar 18 18:00:21 GMT 2025

Visit	<b>Proposal 17709, HD 135344B (02), implementation</b> <b>Diagnostic Status: No Diagnostics</b> Scientific Instruments: STIS/CCD, STIS/FUV-MAMA Special Requirements: (none)										
	Patterns	#	Primary Pattern			Secondary Pattern			Exposures		
		(1)	Pattern Type=STIS-PERP-TO-SLIT	Coordinate Frame=POS-TARG							(2)
		Purpose=DITHER	Pattern Orientation=0.0								
		Number Of Points=7	Angle Between Sides=								
		Point Spacing=0.2	Center Pattern=true								
		Line Spacing=									
Fixed Targets	#	Name	Target Coordinates	Targ. Coord. Corrections		Fluxes	Miscellaneous				
	(2)	CPD-36-6759	RA: 15 15 48.4460 (228.9518583d) Dec: -37 09 16.02 (-37.15445d) Equinox: J2000	Proper Motion RA: -19.21 mas/yr Proper Motion Dec: -23.267999904419412 mas/yr Parallax: 0.0074074" Epoch of Position: 2000		V=8.708	Reference Frame: ICRS				
	<i>Comments: This object was generated by the targetselector and retrieved from the SIMBAD database.</i> <i>SIMBAD listed proper motion for this target. When retrieving targets with PM from SIMBAD, APT requests the coordinates be calculated with an epoch of the year 2000. Do not modify this epoch. Always review coordinates using the Target Confirmation tool, which graphically displays the PM.</i> Category=STAR Description=[HERBIG AE/BE, PROTOPLANETARY DISK]										
Exposures	#	Label (ETC Run)	Target	Config,Mode,Aperture	Spectral Els.	Opt. Params.	Special Reqs.	Groups	Exp. Time (Total)/[Actual Dur.]		Orbit
	1	HD135344B Target Acquisition	(2) CPD-36-6759	STIS/CCD, ACQ, F28X500II	MIRROR					5.0 Secs (5 Secs) [==>]	[1]
	2	(STIS.sp.19 19564)	(2) CPD-36-6759	STIS/FUV-MAMA, ACCUM, 52X0.2	G140M 1222 A			Pattern 1, Exps 2-2 in HD 135344B (02) (1)	1224 Secs (6525 Secs) [==>1222.0 Secs (Pattern 1)] [==>709.0 Secs (Pattern 2)] [==>1222.0 Secs (Pattern 3)] [==>1100.0 Secs (Pattern 4)] [==>1222.0 Secs (Pattern 5)] [==>525.0 Secs (Pattern 6)] [==>525.0 Secs (Pattern 7)]	[1] [2] [3]	

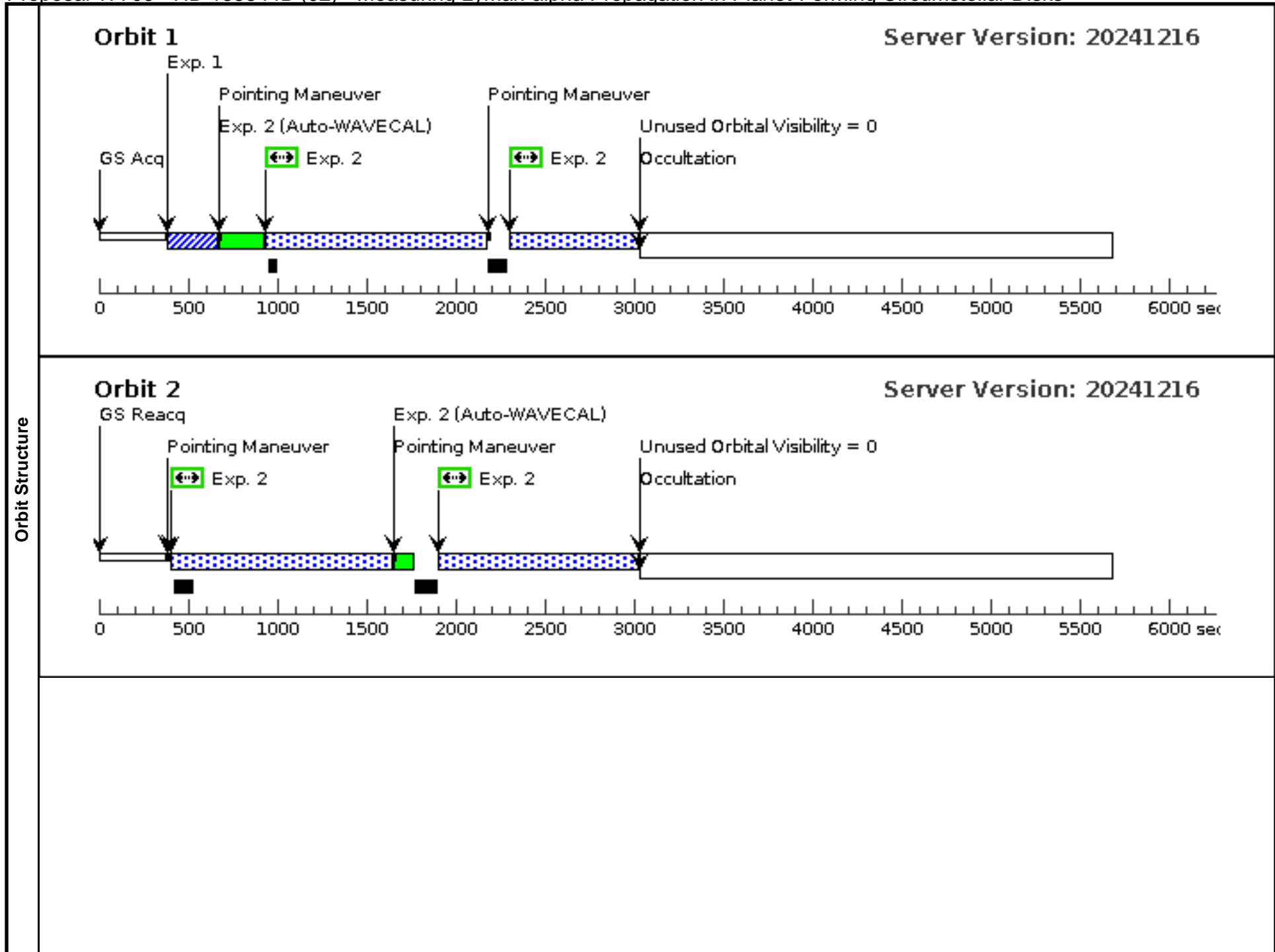

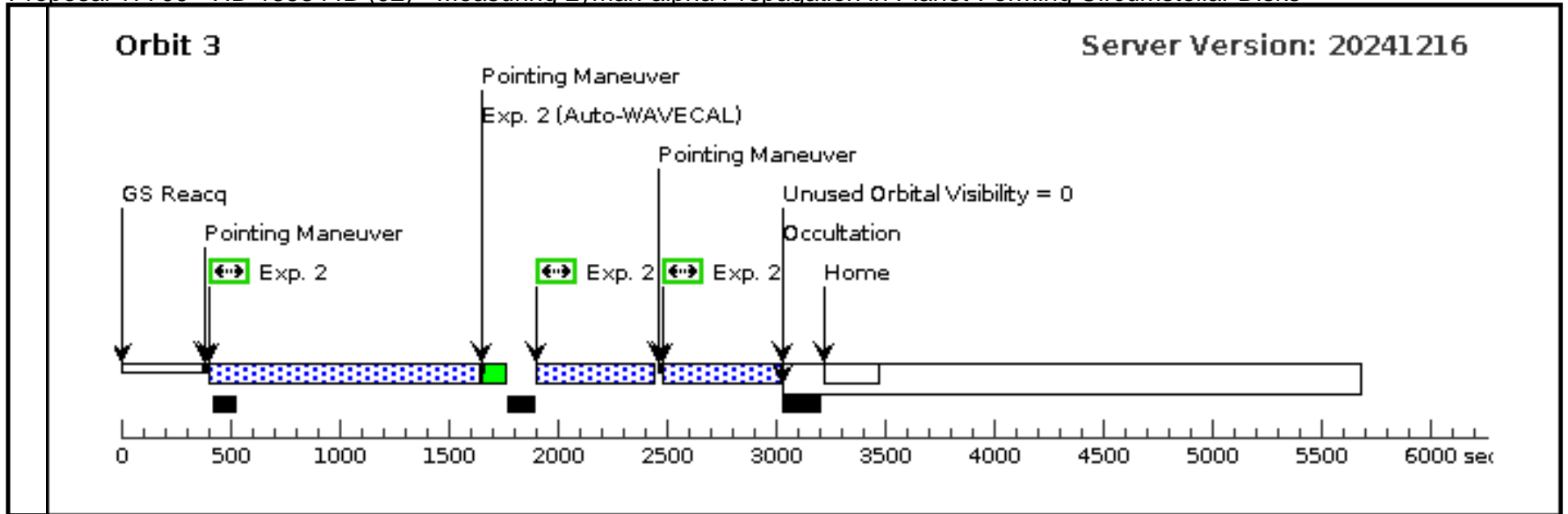

Proposal 17709 - AB Aur (03) - Measuring Lyman-alpha Propagation in Planet-Forming Circumstellar Disks

Tue Mar 18 18:00:21 GMT 2025

<b>Visit</b>	<b>Proposal 17709, AB Aur (03), implementation</b> <b>Diagnostic Status: No Diagnostics</b> Scientific Instruments: STIS/CCD, STIS/FUV-MAMA Special Requirements: (none)											
	<b>Patterns</b>	<b>#</b>	<b>Primary Pattern</b>				<b>Secondary Pattern</b>			<b>Exposures</b>		
(1)		Pattern Type=STIS-PERP-TO-SLIT	Coordinate Frame=POS-TARG						(2)			
		Purpose=DITHER	Pattern Orientation=0.0									
		Number Of Points=7	Angle Between Sides=									
		Point Spacing=0.2	Center Pattern=true									
		Line Spacing=										
<b>Fixed Targets</b>	<b>#</b>	<b>Name</b>	<b>Target Coordinates</b>	<b>Targ. Coord. Corrections</b>		<b>Fluxes</b>	<b>Miscellaneous</b>					
	(3)	V-AB-AUR	RA: 04 55 45.8459 (73.9410246d) Dec: +30 33 4.29 (30.55119d) Equinox: J2000	Proper Motion RA: 4.018 mas/yr Proper Motion Dec: -24.027000063142623 mas/yr Parallax: 0.0064127" Epoch of Position: 2000		V=7.05	Reference Frame: ICRS					
	<i>Comments: This object was generated by the targetselector and retrieved from the SIMBAD database.</i> <i>SIMBAD listed proper motion for this target. When retrieving targets with PM from SIMBAD, APT requests the coordinates be calculated with an epoch of the year 2000. Do not modify this epoch. Always review coordinates using the Target Confirmation tool, which graphically displays the PM.</i> Category=STAR Description=[HERBIG AE/BE, PROTOPLANETARY DISK]											
<b>Exposures</b>	<b>#</b>	<b>Label (ETC Run)</b>	<b>Target</b>	<b>Config,Mode,Aperture</b>	<b>Spectral Els.</b>	<b>Opt. Params.</b>	<b>Special Reqs.</b>	<b>Groups</b>	<b>Exp. Time (Total)/[Actual Dur.]</b>		<b>Orbit</b>	
	1	AB Aur Target Acquisition	(3) V-AB-AUR	STIS/CCD, ACQ, F28X500II	MIRROR				2.0 Secs (2 Secs)			
									[==>]		[1]	
	2	(STIS.sp.19 19570)	(3) V-AB-AUR	STIS/FUV-MAMA, ACCUM, 52X0.2	G140M 1222 A				Pattern 1, Exps 2-2 in AB Aur (03) (1)	1181 Secs (6522 Secs)		
										[==>1181 Secs (Pattern 1)]		[1]
										[==>757.0 Secs (Pattern 2)]		
										[==>1181.0 Secs (Pattern 3)]		[2]
									[==>1136.0 Secs (Pattern 4)]			
									[==>1181.0 Secs (Pattern 5)]			
									[==>543.0 Secs (Pattern 6)]		[3]	
									[==>543.0 Secs (Pattern 7)]			

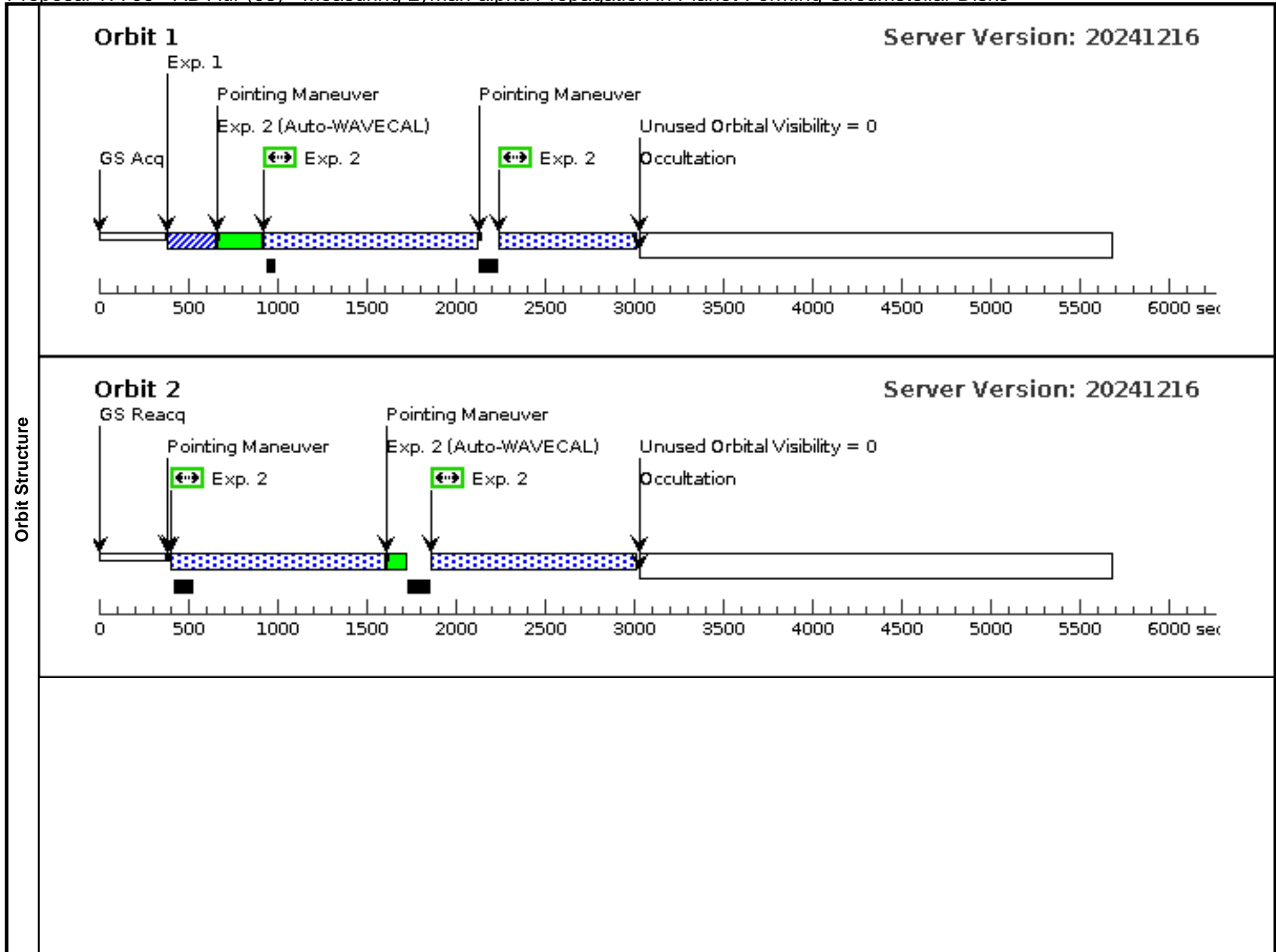

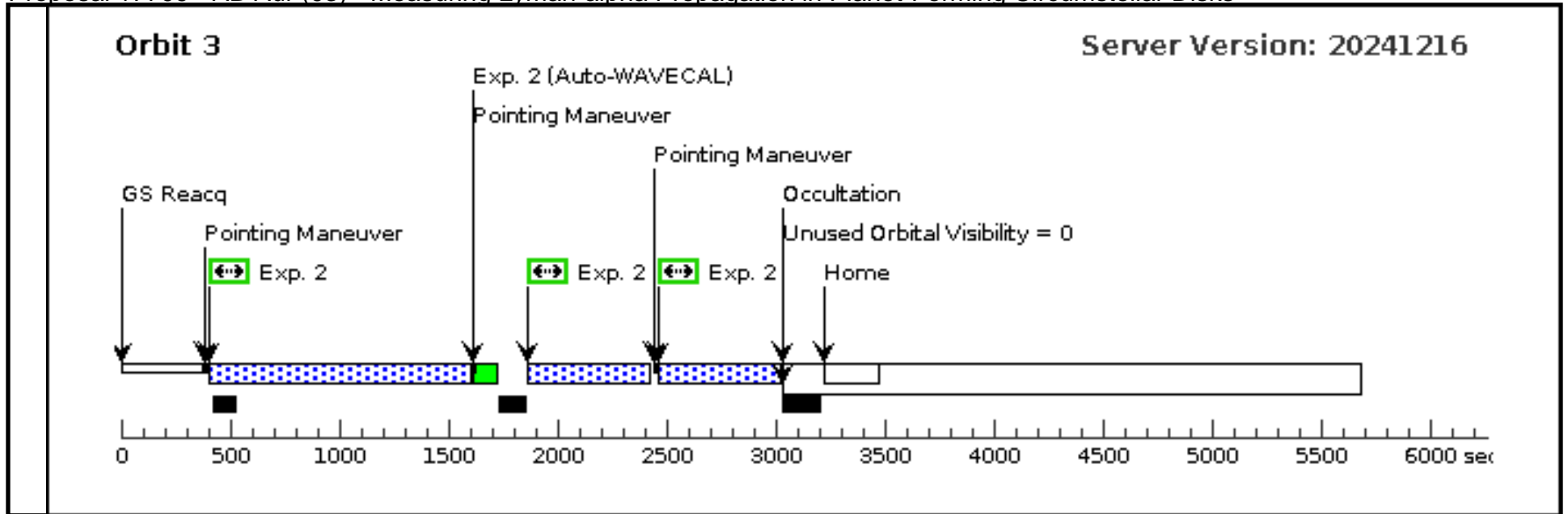

Proposal 17709 - HD 163296 (04) - Measuring Lyman-alpha Propagation in Planet-Forming Circumstellar Disks

Tue Mar 18 18:00:21 GMT 2025

<b>Visit</b>	<b>Proposal 17709, HD 163296 (04), implementation</b> <b>Diagnostic Status: No Diagnostics</b> Scientific Instruments: STIS/CCD, STIS/FUV-MAMA Special Requirements: (none)											
	<b>Patterns</b>	<b>#</b>	<b>Primary Pattern</b>				<b>Secondary Pattern</b>			<b>Exposures</b>		
(1)		Pattern Type=STIS-PERP-TO-SLIT Purpose=DITHER Number Of Points=7 Point Spacing=0.2 Line Spacing=	Coordinate Frame=POS-TARG Pattern Orientation=0.0 Angle Between Sides= Center Pattern=true						(2)			
<b>Fixed Targets</b>	<b>#</b>	<b>Name</b>	<b>Target Coordinates</b>	<b>Targ. Coord. Corrections</b>		<b>Fluxes</b>	<b>Miscellaneous</b>					
	(4)	HD-163296	RA: 17 56 21.2882 (269.0887008d) Dec: -21 57 21.87 (-21.95607d) Equinox: J2000	Proper Motion RA: -7.586 mas/yr Proper Motion Dec: -39.45799990106025 mas/yr Parallax: 0.0099043" Epoch of Position: 2000	V=6.85		Reference Frame: ICRS					
<i>Comments: This object was generated by the targetselector and retrieved from the SIMBAD database.</i> SIMBAD listed proper motion for this target. When retrieving targets with PM from SIMBAD, APT requests the coordinates be calculated with an epoch of the year 2000. Do not modify this epoch. Always review coordinates using the Target Confirmation tool, which graphically displays the PM. Category=STAR Description=[HERBIG AE/BE, PROTOPLANETARY DISK]												
<b>Exposures</b>	<b>#</b>	<b>Label (ETC Run)</b>	<b>Target</b>	<b>Config,Mode,Aperture</b>	<b>Spectral Els.</b>	<b>Opt. Params.</b>	<b>Special Reqs.</b>	<b>Groups</b>	<b>Exp. Time (Total)/[Actual Dur.]</b>		<b>Orbit</b>	
	1	HD 163296 Target Acquisition	(4) HD-163296	STIS/CCD, ACQ, F28X500II	MIRROR				2.0 Secs (2 Secs)			
									[==>]		[1]	
	2	(STIS.sp.19 19579)	(4) HD-163296	STIS/FUV-MAMA, ACCUM, 52X0.2	G140M 1222 A				Pattern 1, Exps 2-2 in HD 163296 (04) (1)	1626 Secs (9152 Secs)		
										[==>(Pattern 1)]		[1]
										[==>306.0 Secs (Pattern 2)]		[2]
										[==>(Pattern 3)]		[3]
									[==>685.0 Secs (Pattern 4)]		[4]	
									[==>(Pattern 5)]		[1]	
									[==>685.0 Secs (Pattern 6)]		[2]	
									[==>2598.0 Secs (Pattern 7)]		[3]	

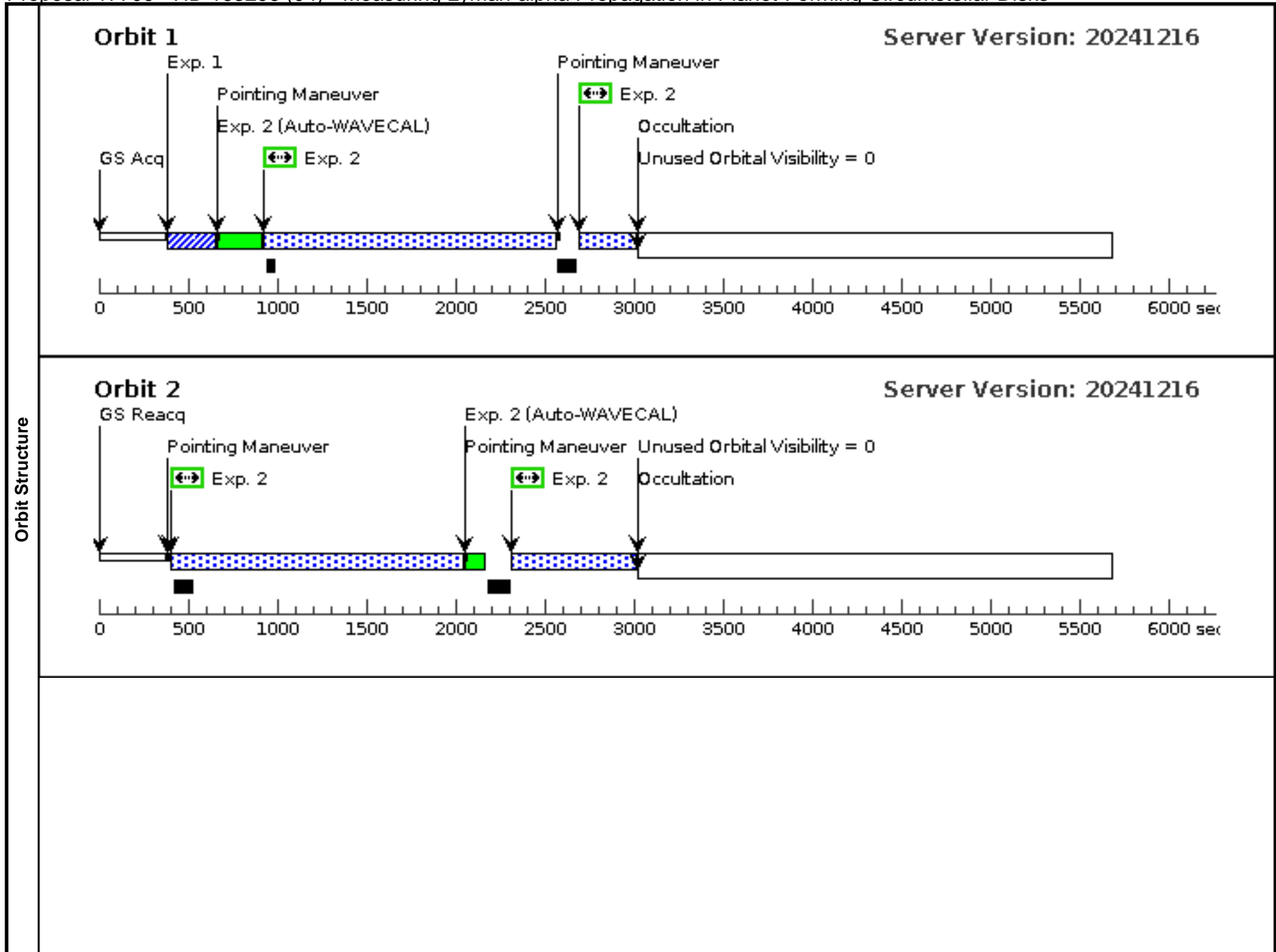

**Orbit 3**

Server Version: 20241216

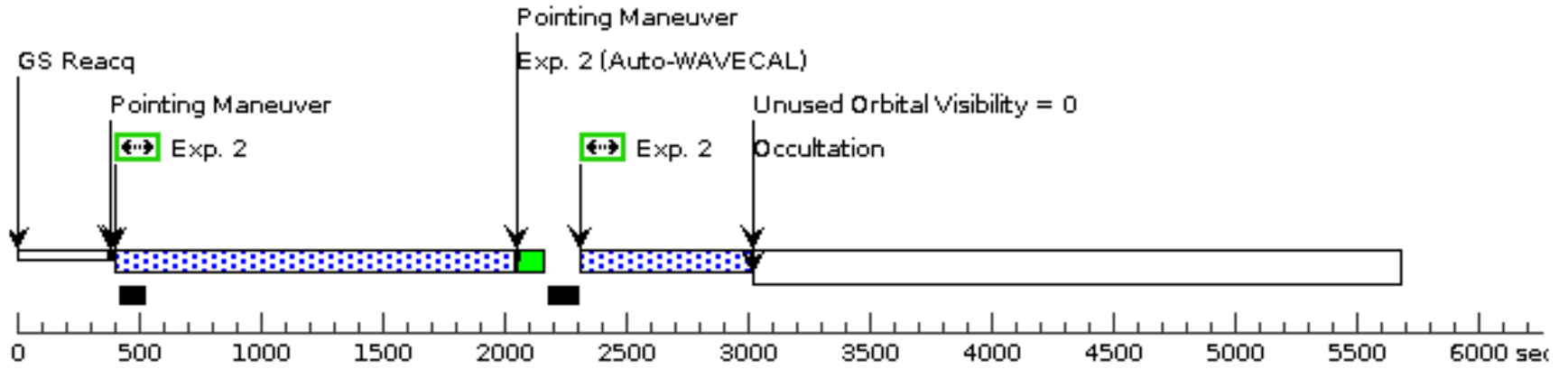

**Orbit 4**

Server Version: 20241216

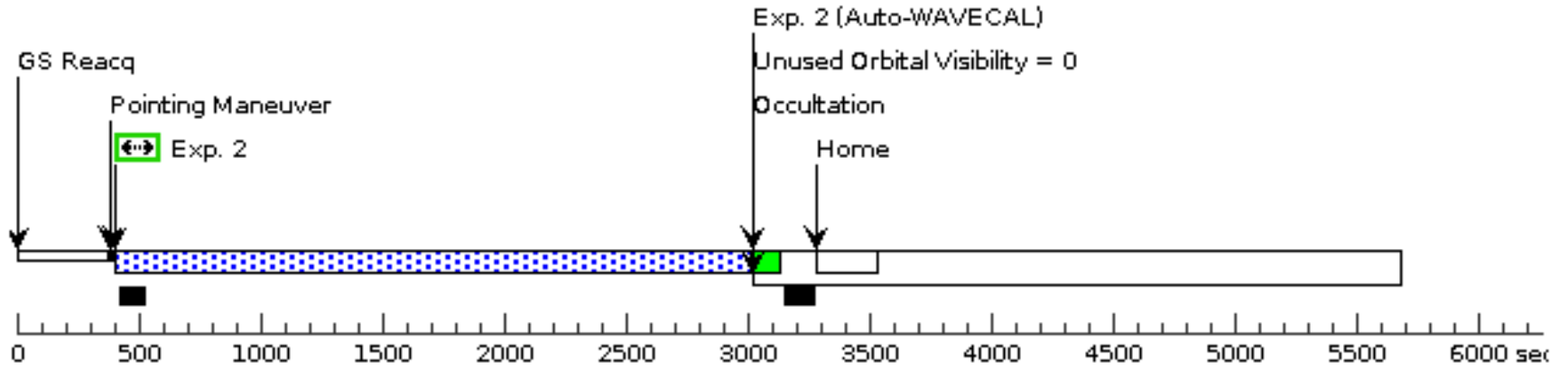

Proposal 17709 - T Cha (05) - Measuring Lyman-alpha Propagation in Planet-Forming Circumstellar Disks

Tue Mar 18 18:00:21 GMT 2025

<b>Visit</b>	<b>Proposal 17709, T Cha (05), implementation</b> <b>Diagnostic Status: No Diagnostics</b> Scientific Instruments: STIS/CCD, STIS/FUV-MAMA Special Requirements: (none)										
	<b>Patterns</b>	<b>#</b>	<b>Primary Pattern</b>				<b>Secondary Pattern</b>			<b>Exposures</b>	
(2)		Pattern Type=STIS-PERP-TO-SLIT Purpose=DITHER Number Of Points=5 Point Spacing=0.2 Line Spacing=		Coordinate Frame=POS-TARG Pattern Orientation=0.0 Angle Between Sides= Center Pattern=true					(2)		
<b>Fixed Targets</b>	<b>#</b>	<b>Name</b>	<b>Target Coordinates</b>		<b>Targ. Coord. Corrections</b>		<b>Fluxes</b>	<b>Miscellaneous</b>			
	(5)	V-T-CHA	RA: 11 57 13.5245 (179.3063521d) Dec: -79 21 31.53 (-79.35876d) Equinox: J2000		Proper Motion RA: -41.586 mas/yr Proper Motion Dec: -8.654999942336872 mas/yr Parallax: 0.0097356" Epoch of Position: 2000		V=11.86	Reference Frame: ICRS			
<i>Comments: This object was generated by the target selector and retrieved from the SIMBAD database.</i> <i>SIMBAD listed proper motion for this target. When retrieving targets with PM from SIMBAD, APT requests the coordinates be calculated with an epoch of the year 2000. Do not modify this epoch. Always review coordinates using the Target Confirmation tool, which graphically displays the PM.</i> Category=STAR Description=[PROTOPLANETARY DISK, T TAURI STAR]											
<b>Exposures</b>	<b>#</b>	<b>Label (ETC Run)</b>	<b>Target</b>	<b>Config,Mode,Aperture</b>	<b>Spectral Els.</b>	<b>Opt. Params.</b>	<b>Special Reqs.</b>	<b>Groups</b>	<b>Exp. Time (Total)/[Actual Dur.]</b>		<b>Orbit</b>
	1	T Cha Target Acquisition	(5) V-T-CHA	STIS/CCD, ACQ, F28X50OII	MIRROR				10.0 Secs (10 Secs)		
									[==>]		[1]
	2	(STIS.sp.19 19521)	(5) V-T-CHA	STIS/FUV-MAMA, ACCUM, 52X0.2	G140M 1222 A			Pattern 2, Exps 2-2 in T Cha (05) (2)	4077 Secs (13385 Secs)		
									[==>2233.0 Secs (Pattern 1)]		[1]
									[==>2788.0 Secs (Pattern 2)]		[2]
									[==>2788.0 Secs (Pattern 3)]		[3]
								[==>2788.0 Secs (Pattern 4)]		[4]	
								[==>2788.0 Secs (Pattern 5)]		[5]	

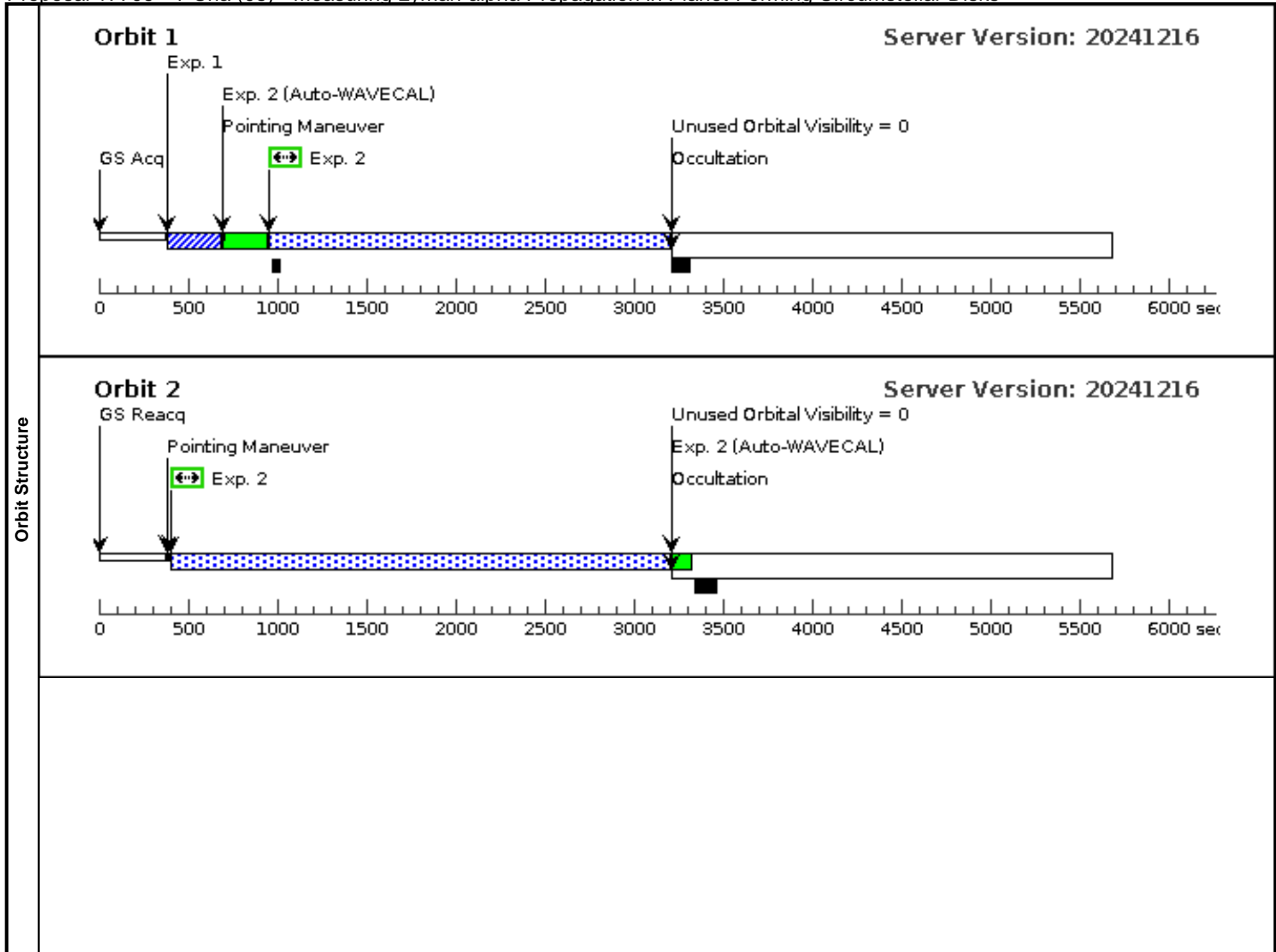

### Orbit 3

Server Version: 20241216

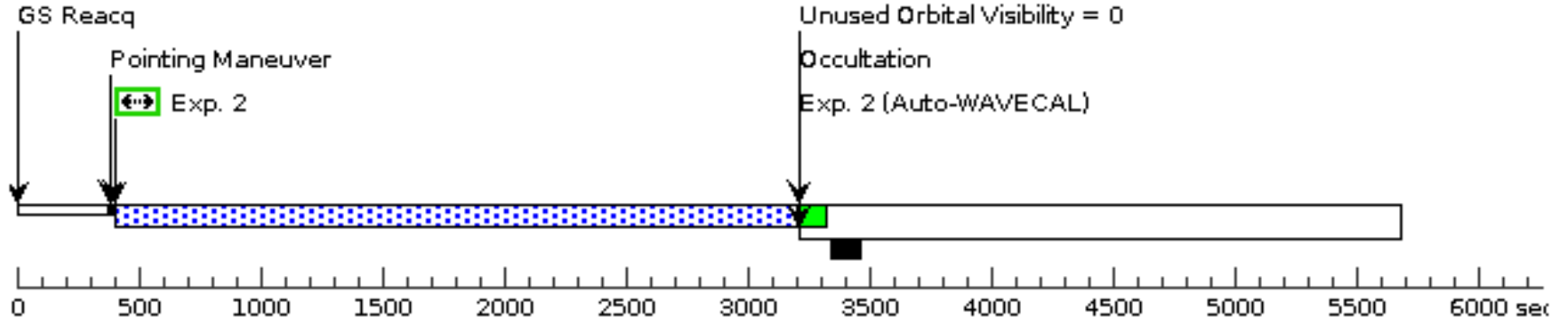

### Orbit 4

Server Version: 20241216

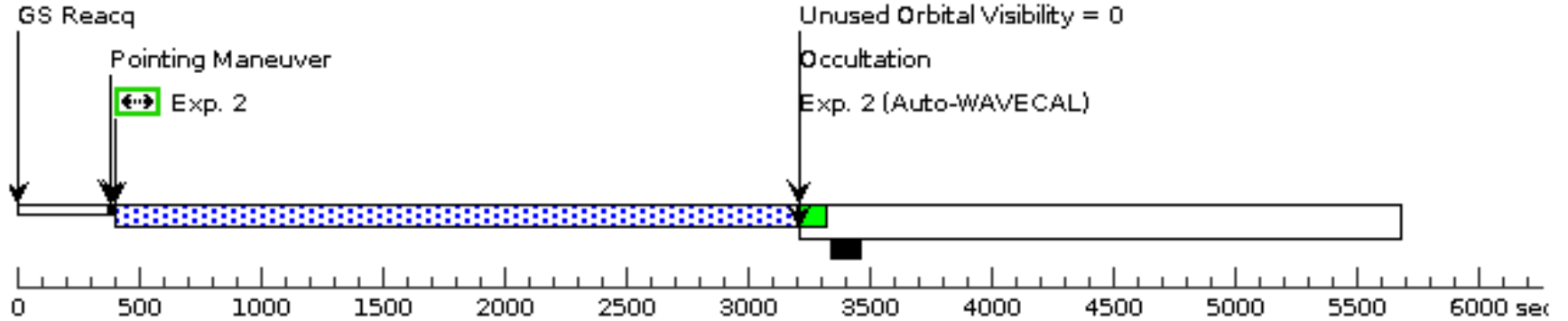

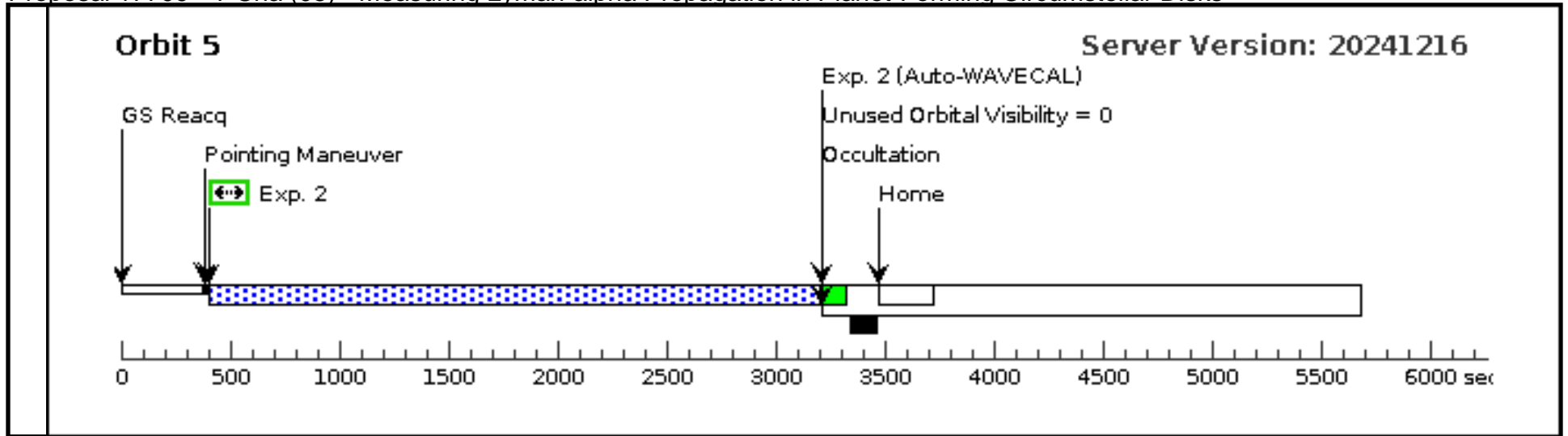

Proposal 17709 - T Cha (09) - Measuring Lyman-alpha Propagation in Planet-Forming Circumstellar Disks

Tue Mar 18 18:00:21 GMT 2025

<b>Visit</b>	<b>Proposal 17709, T Cha (09), implementation</b> <b>Diagnostic Status: No Diagnostics</b> Scientific Instruments: STIS/CCD, STIS/FUV-MAMA Special Requirements: (none)											
	<b>Patterns</b>	<b>#</b>	<b>Primary Pattern</b>				<b>Secondary Pattern</b>				<b>Exposures</b>	
(2)		Pattern Type=STIS-PERP-TO-SLIT		Coordinate Frame=POS-TARG						(2)		
<b>Fixed Targets</b>	<b>#</b>	<b>Name</b>	<b>Target Coordinates</b>		<b>Targ. Coord. Corrections</b>		<b>Fluxes</b>	<b>Miscellaneous</b>				
	(5)	V-T-CHA	RA: 11 57 13.5245 (179.3063521d) Dec: -79 21 31.53 (-79.35876d) Equinox: J2000		Proper Motion RA: -41.586 mas/yr Proper Motion Dec: -8.654999942336872 mas/yr Parallax: 0.0097356" Epoch of Position: 2000		V=11.86	Reference Frame: ICRS				
<i>Comments: This object was generated by the target selector and retrieved from the SIMBAD database.</i> <i>SIMBAD listed proper motion for this target. When retrieving targets with PM from SIMBAD, APT requests the coordinates be calculated with an epoch of the year 2000. Do not modify this epoch. Always review coordinates using the Target Confirmation tool, which graphically displays the PM.</i> Category=STAR Description=[PROTOPLANETARY DISK, T TAURI STAR]												
<b>Exposures</b>	<b>#</b>	<b>Label (ETC Run)</b>	<b>Target</b>	<b>Config,Mode,Aperture</b>	<b>Spectral Els.</b>	<b>Opt. Params.</b>	<b>Special Reqs.</b>	<b>Groups</b>	<b>Exp. Time (Total)/[Actual Dur.]</b>		<b>Orbit</b>	
	1	T Cha Target Acquisition	(5) V-T-CHA	STIS/CCD, ACQ, F28X50OII	MIRROR				10.0 Secs (10 Secs)			
									[==>]		[1]	
	2	(STIS.sp.19 19521)	(5) V-T-CHA	STIS/FUV-MAMA, ACCUM, 52X0.2	G140M 1222 A				Pattern 2, Exps 2-2 in T Cha (09) (2)	4077 Secs (13385 Secs)		
										[==>2233.0 Secs (Pattern 1)]		[1]
										[==>2788.0 Secs (Pattern 2)]		[2]
										[==>2788.0 Secs (Pattern 3)]		[3]
									[==>2788.0 Secs (Pattern 4)]		[4]	
									[==>2788.0 Secs (Pattern 5)]		[5]	

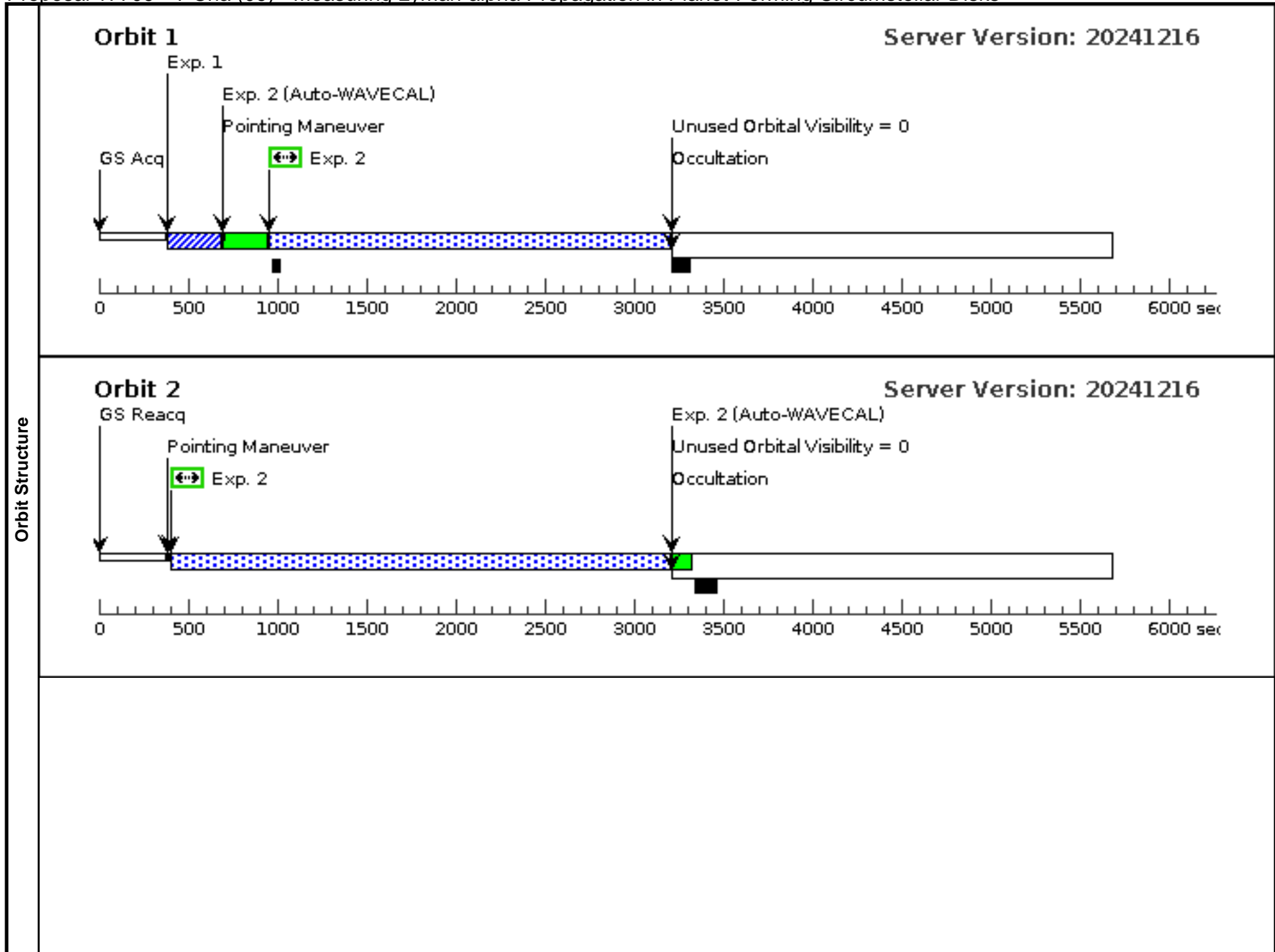

### Orbit 3

Server Version: 20241216

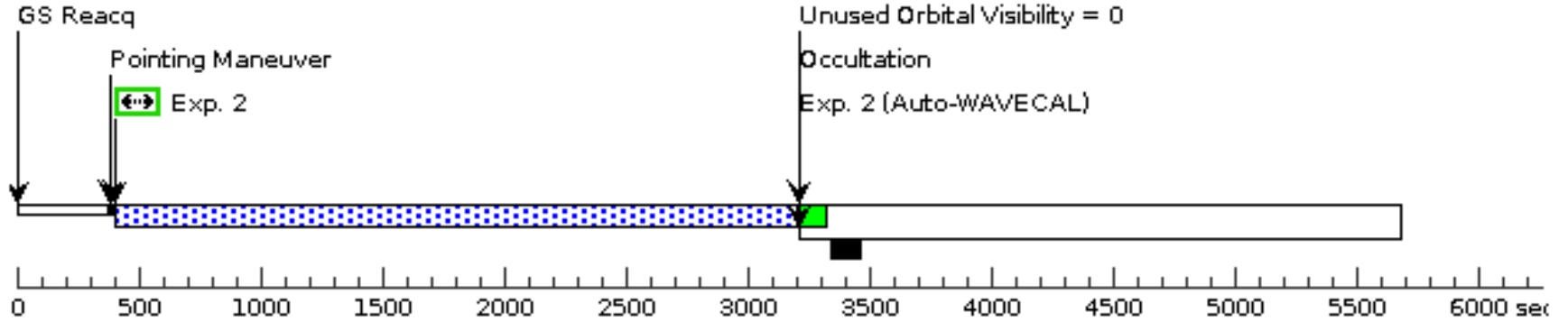

### Orbit 4

Server Version: 20241216

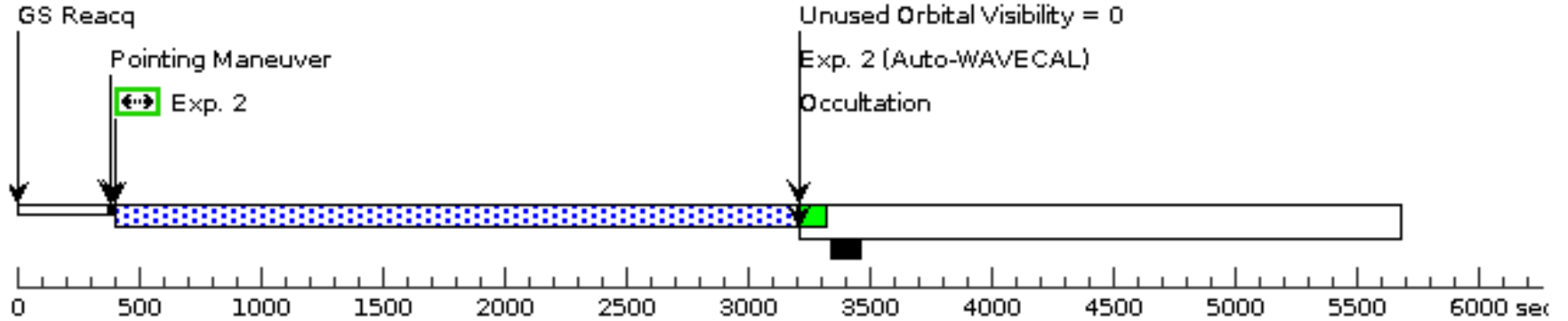

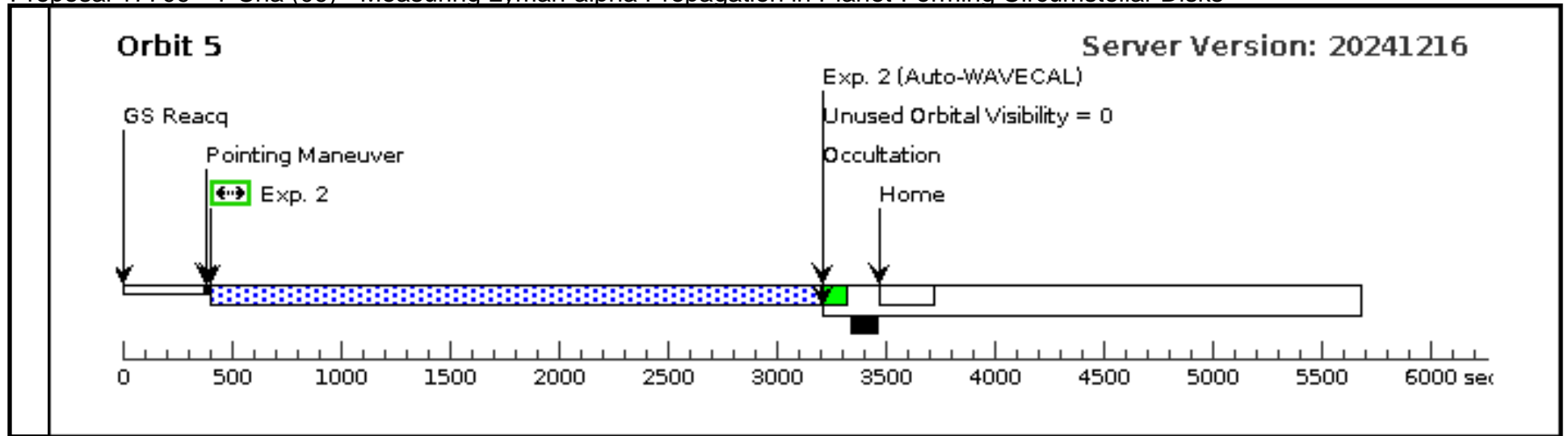

Proposal 17709 - T Cha (11) - Measuring Lyman-alpha Propagation in Planet-Forming Circumstellar Disks

Tue Mar 18 18:00:21 GMT 2025

<b>Visit</b>	<b>Proposal 17709, T Cha (11), implementation</b> <b>Diagnostic Status: No Diagnostics</b> Scientific Instruments: STIS/CCD, STIS/FUV-MAMA Special Requirements: (none)										
	<b>Patterns</b>	<b>#</b>	<b>Primary Pattern</b>				<b>Secondary Pattern</b>				<b>Exposures</b>
(5)		Pattern Type=STIS-PERP-TO-SLIT Purpose=DITHER Number Of Points=2 Point Spacing=1.2 Line Spacing=	Coordinate Frame=POS-TARG Pattern Orientation=0.0 Angle Between Sides= Center Pattern=true							(2)	
<b>Fixed Targets</b>	<b>#</b>	<b>Name</b>	<b>Target Coordinates</b>	<b>Targ. Coord. Corrections</b>		<b>Fluxes</b>	<b>Miscellaneous</b>				
	(5)	V-T-CHA	RA: 11 57 13.5245 (179.3063521d) Dec: -79 21 31.53 (-79.35876d) Equinox: J2000	Proper Motion RA: -41.586 mas/yr Proper Motion Dec: -8.654999942336872 mas/yr Parallax: 0.0097356" Epoch of Position: 2000	V=11.86	Reference Frame: ICRS					
<p><i>Comments: This object was generated by the target selector and retrieved from the SIMBAD database.</i></p> <p><i>SIMBAD listed proper motion for this target. When retrieving targets with PM from SIMBAD, APT requests the coordinates be calculated with an epoch of the year 2000. Do not modify this epoch. Always review coordinates using the Target Confirmation tool, which graphically displays the PM.</i></p> <p>Category=STAR Description=[PROTOPLANETARY DISK, T TAURI STAR]</p>											
<b>Exposures</b>	<b>#</b>	<b>Label (ETC Run)</b>	<b>Target</b>	<b>Config,Mode,Aperture</b>	<b>Spectral Els.</b>	<b>Opt. Params.</b>	<b>Special Reqs.</b>	<b>Groups</b>	<b>Exp. Time (Total)/[Actual Dur.]</b>		<b>Orbit</b>
	1	T Cha Target Acquisition	(5) V-T-CHA	STIS/CCD, ACQ, F28X500II	MIRROR				10.0 Secs (10 Secs)		
									[==>]		[1]
	2	(STIS.sp.19 19521)	(5) V-T-CHA	STIS/FUV-MAMA, ACCUM, 52X0.2	G140M 1222 A				Pattern 5, Exps 2-2 in T Cha (11) (5)	4077 Secs (5021 Secs)	
									[==>2233.0 Secs (Pattern 1)]		[1]
									[==>2788.0 Secs (Pattern 2)]		[2]

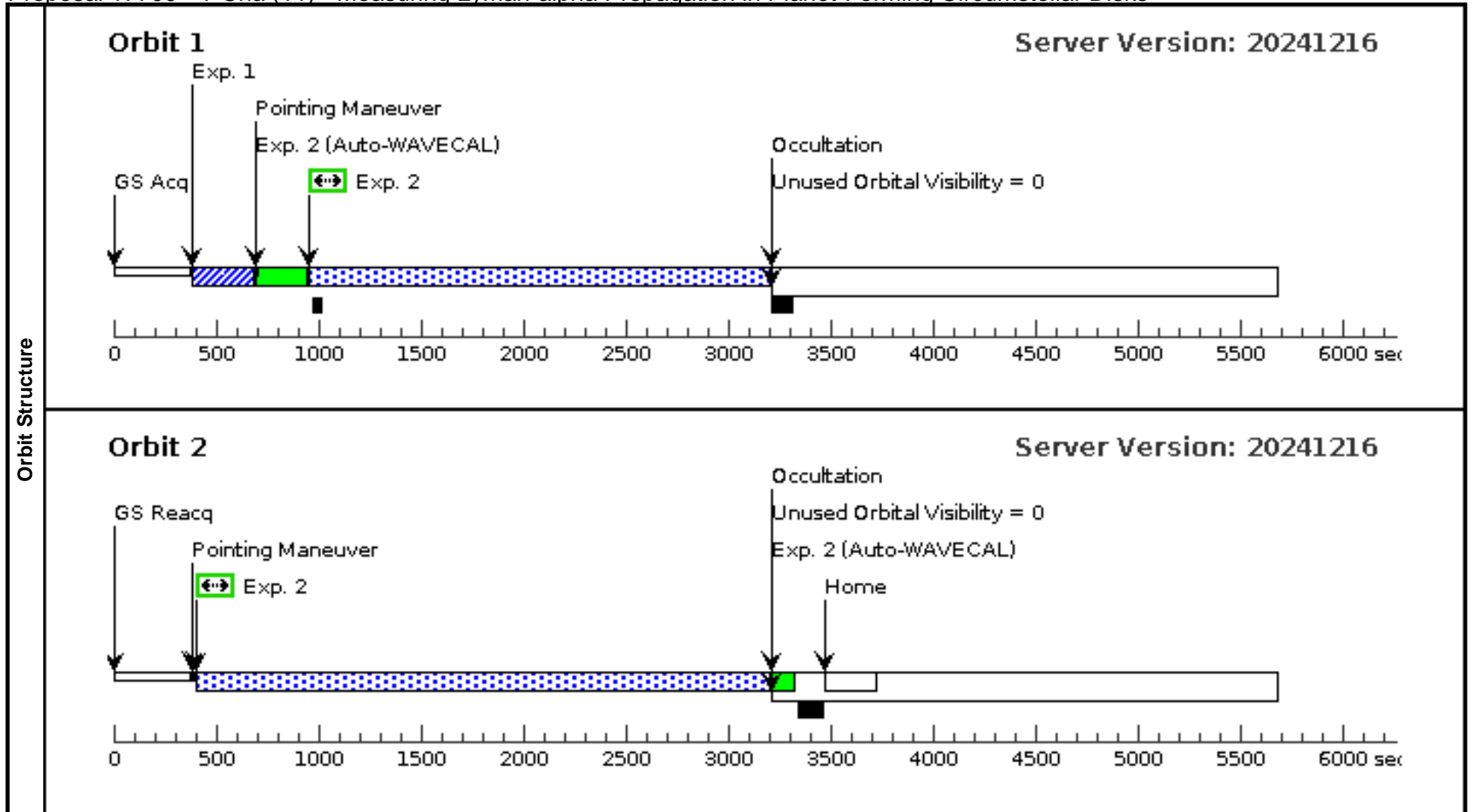

Proposal 17709 - Tau 042021 (08) - Measuring Lyman-alpha Propagation in Planet-Forming Circumstellar Disks

Tue Mar 18 18:00:21 GMT 2025

Visit	<b>Proposal 17709, Tau 042021 (08), implementation</b> <b>Diagnostic Status: No Diagnostics</b> Scientific Instruments: STIS/CCD, STIS/FUV-MAMA Special Requirements: (none)									
	Patterns	#	Primary Pattern			Secondary Pattern			Exposures	
		(3)	Pattern Type=STIS-PERP-TO-SLIT	Coordinate Frame=POS-TARG						
		Purpose=DITHER	Pattern Orientation=0.0							
		Number Of Points=5	Angle Between Sides=							
		Point Spacing=0.4	Center Pattern=true							
		Line Spacing=								
Fixed Targets	#	Name	Target Coordinates	Targ. Coord. Corrections	Fluxes	Miscellaneous				
	(6)	2MASS-J04202144+2813491	RA: 04 20 21.4428 (65.0893450d) Dec: +28 13 49.17 (28.23032d) Equinox: J2000	Epoch of Position: 2000	V=18.5	Reference Frame: ICRS				
	<i>Comments: This object was generated by the targetselector and retrieved from the SIMBAD database.</i> Category=STAR Description=[PROTOPLANETARY DISK, T TAURI STAR]									
Exposures	#	Label (ETC Run)	Target	Config,Mode,Aperture	Spectral Els.	Opt. Params.	Special Reqs.	Groups	Exp. Time (Total)/[Actual Dur.]	Orbit
	1	Tau 042021 Target Acquisition (STIS.ta.1954484)	(6) 2MASS-J04202144+2813491	STIS/CCD, ACQ, F28X50LP	MIRROR				23 Secs (23 Secs)	
								[==>]	[1]	
	2	(STIS.sp.1919521)	(6) 2MASS-J04202144+2813491	STIS/FUV-MAMA, ACCUM, 52X0.2	G140M 1222 A			Pattern 3, Exps 2-2 in Tau 042021 (08) (3)	4077 Secs (12403 Secs)	
								[==>1995 Secs (Pattern 1)]	[1]	
								[==>2602.0 Secs (Pattern 2)]	[2]	
								[==>2602.0 Secs (Pattern 3)]	[3]	
								[==>2602.0 Secs (Pattern 4)]	[4]	
								[==>2602.0 Secs (Pattern 5)]	[5]	

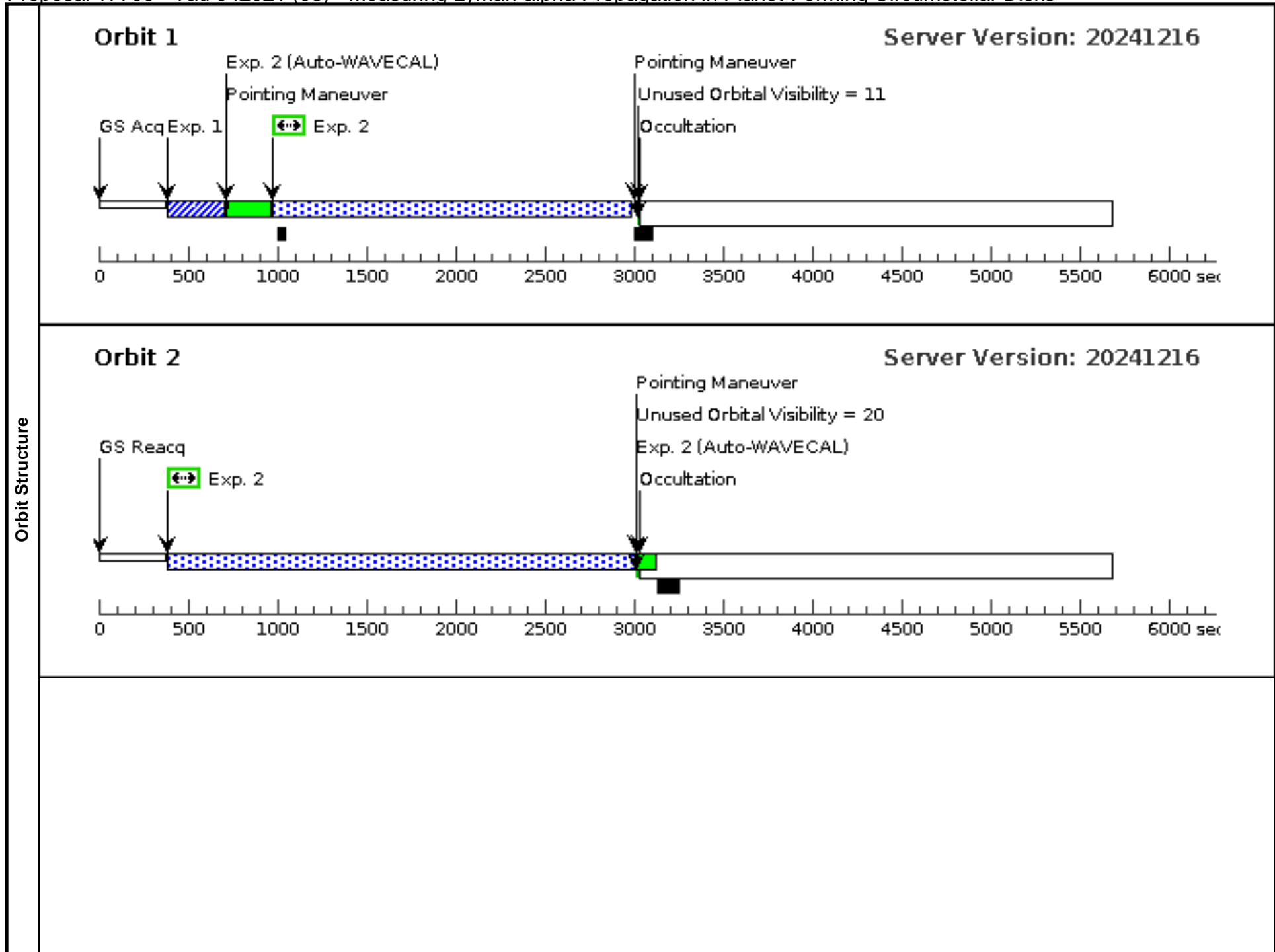

### Orbit 3

Server Version: 20241216

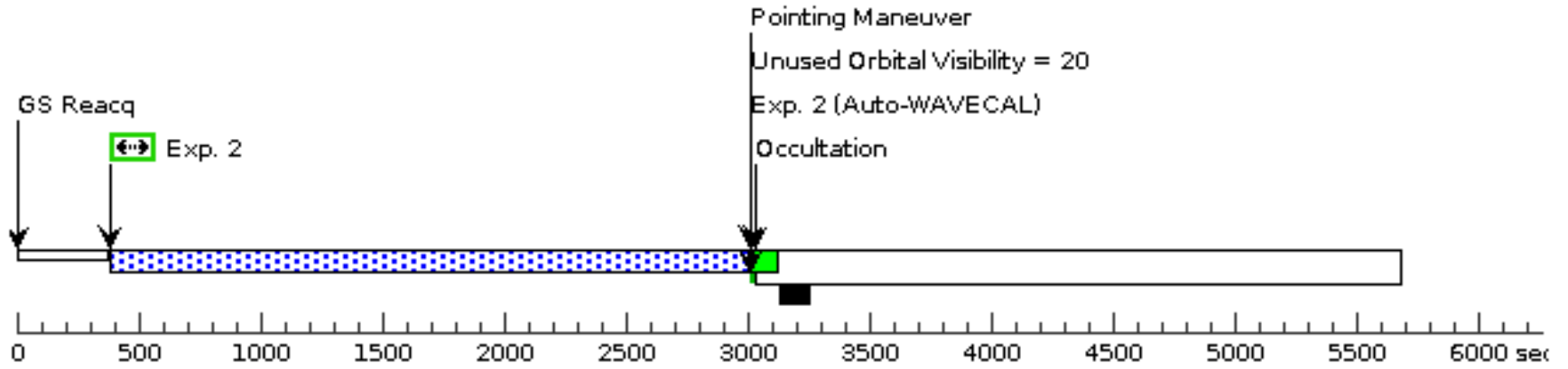

### Orbit 4

Server Version: 20241216

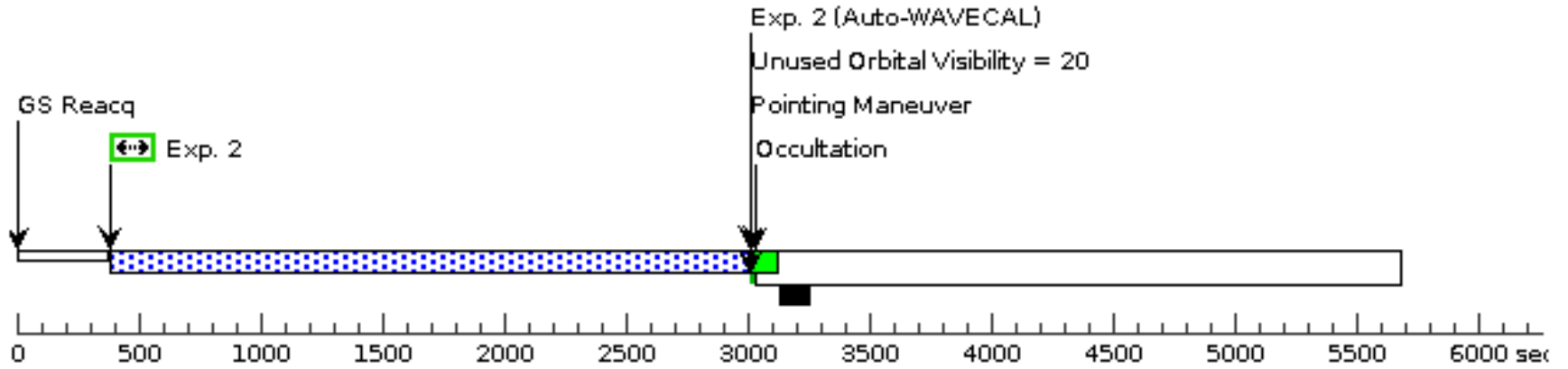

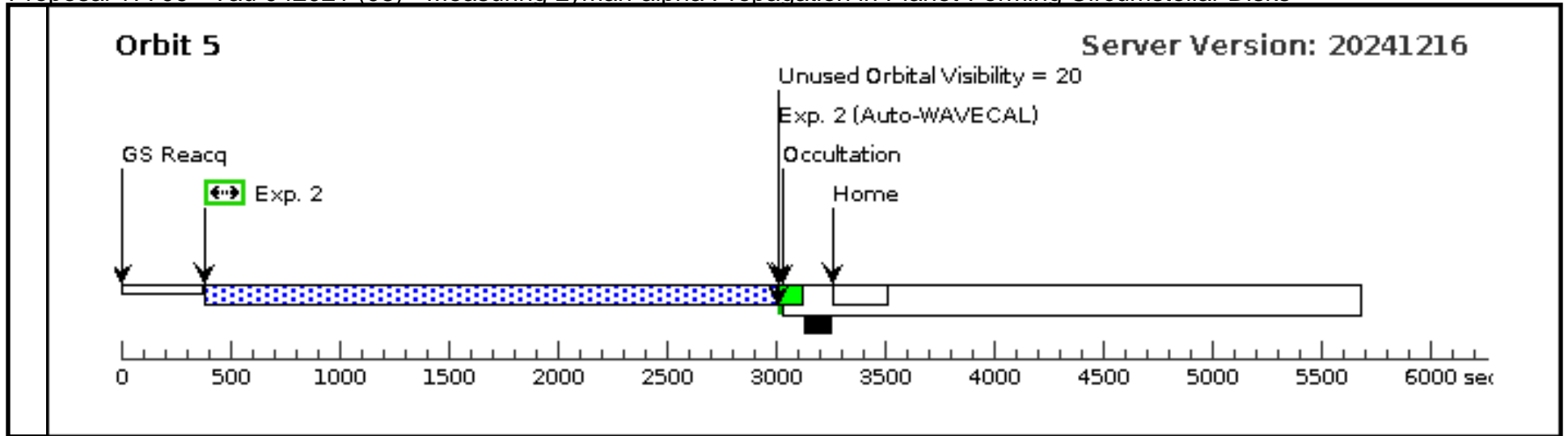

Proposal 17709 - Tau 042021 (10) - Measuring Lyman-alpha Propagation in Planet-Forming Circumstellar Disks

Tue Mar 18 18:00:21 GMT 2025

<b>Visit</b>	<b>Proposal 17709, Tau 042021 (10), implementation</b> <b>Diagnostic Status: No Diagnostics</b> Scientific Instruments: STIS/CCD, STIS/FUV-MAMA Special Requirements: (none)									
	<b>Patterns</b>	<b>#</b>	<b>Primary Pattern</b>				<b>Secondary Pattern</b>			<b>Exposures</b>
(3)		Pattern Type=STIS-PERP-TO-SLIT		Coordinate Frame=POS-TARG					(2)	
<b>Fixed Targets</b>	<b>#</b>	<b>Name</b>	<b>Target Coordinates</b>		<b>Targ. Coord. Corrections</b>		<b>Fluxes</b>	<b>Miscellaneous</b>		
	(6)	2MASS-J04202144+2813491	RA: 04 20 21.4428 (65.0893450d) Dec: +28 13 49.17 (28.23032d) Equinox: J2000		Epoch of Position: 2000		V=18.5	Reference Frame: ICRS		
<i>Comments: This object was generated by the targetselector and retrieved from the SIMBAD database.</i> Category=STAR Description=[PROTOPLANETARY DISK, T TAURI STAR]										
<b>Exposures</b>	<b>#</b>	<b>Label (ETC Run)</b>	<b>Target</b>	<b>Config,Mode,Aperture</b>	<b>Spectral Els.</b>	<b>Opt. Params.</b>	<b>Special Reqs.</b>	<b>Groups</b>	<b>Exp. Time (Total)/[Actual Dur.]</b>	<b>Orbit</b>
	1	Tau 042021 Target Acquisition (STIS.ta.1954484)	(6) 2MASS-J04202144+2813491	STIS/CCD, ACQ, F28X50LP	MIRROR				23 Secs (23 Secs)	
									[==>]	[1]
	2	(STIS.sp.1919521)	(6) 2MASS-J04202144+2813491	STIS/FUV-MAMA, ACCUM, 52X0.2	G140M 1222 A			Pattern 3, Exps 2-2 in Tau 042021 (10) (3)	4077 Secs (12403 Secs)	
									[==>1995 Secs (Pattern 1)]	[1]
									[==>2602.0 Secs (Pattern 2)]	[2]
									[==>2602.0 Secs (Pattern 3)]	[3]
								[==>2602.0 Secs (Pattern 4)]	[4]	
								[==>2602.0 Secs (Pattern 5)]	[5]	

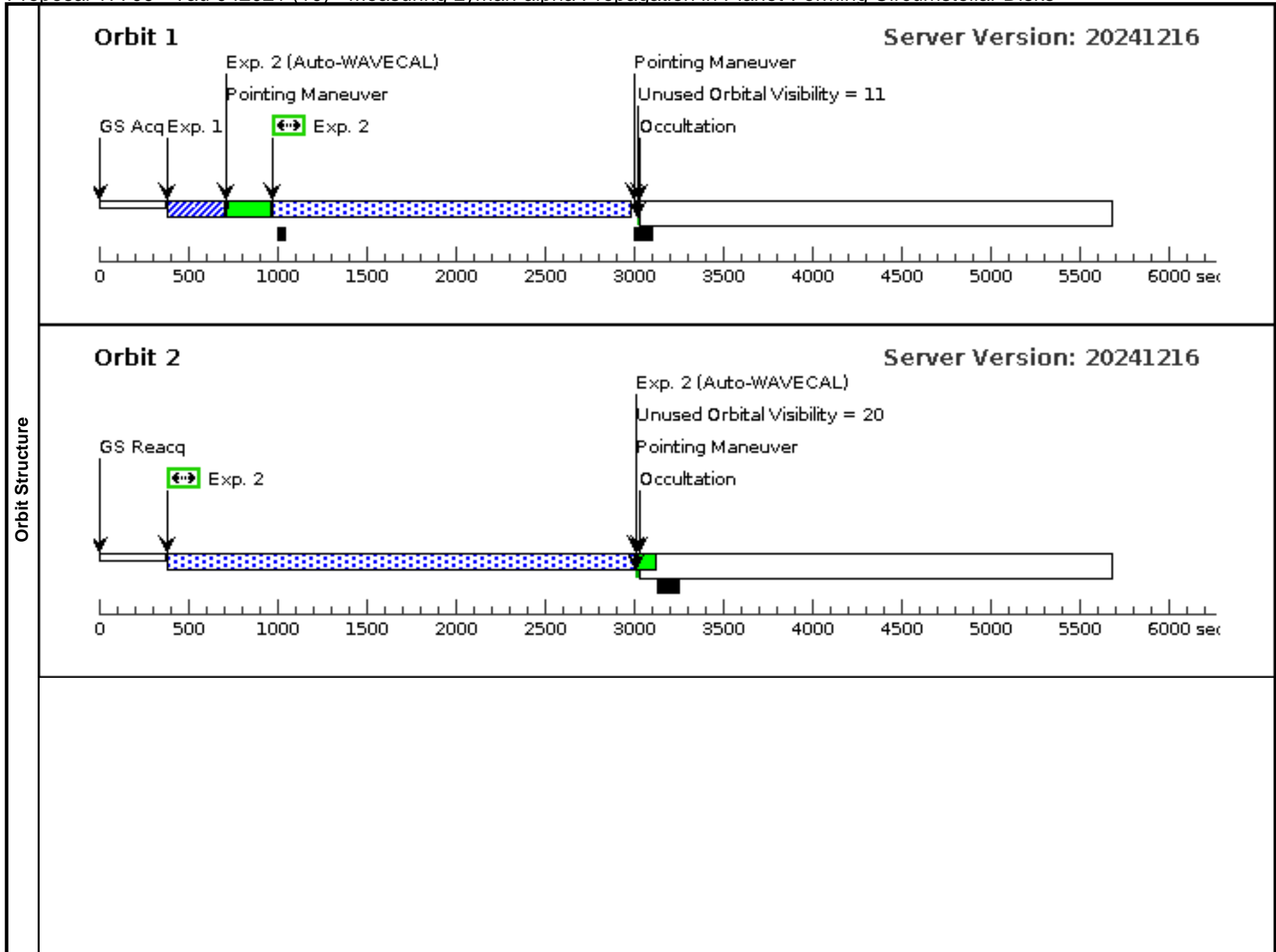

### Orbit 3

Server Version: 20241216

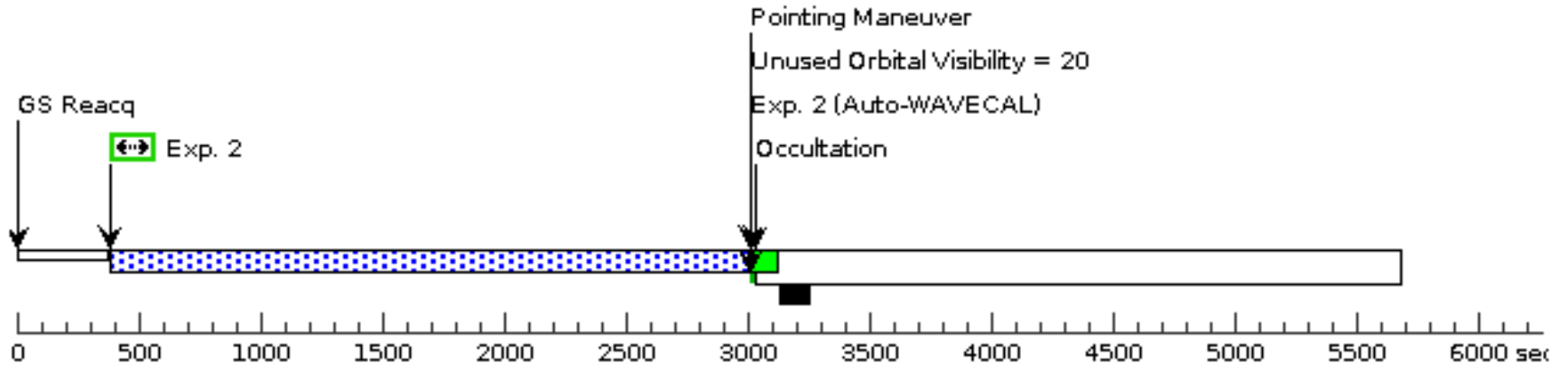

### Orbit 4

Server Version: 20241216

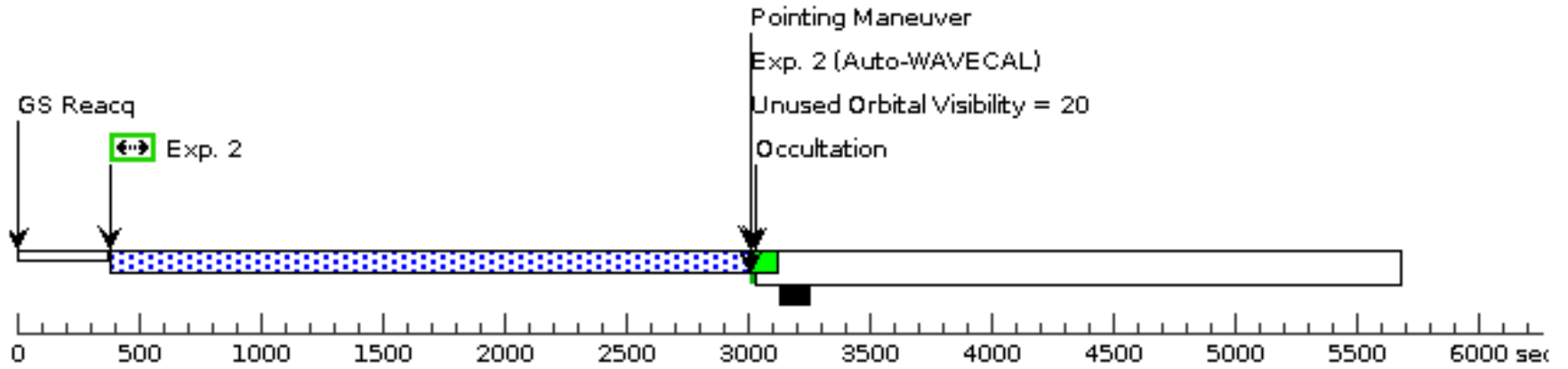

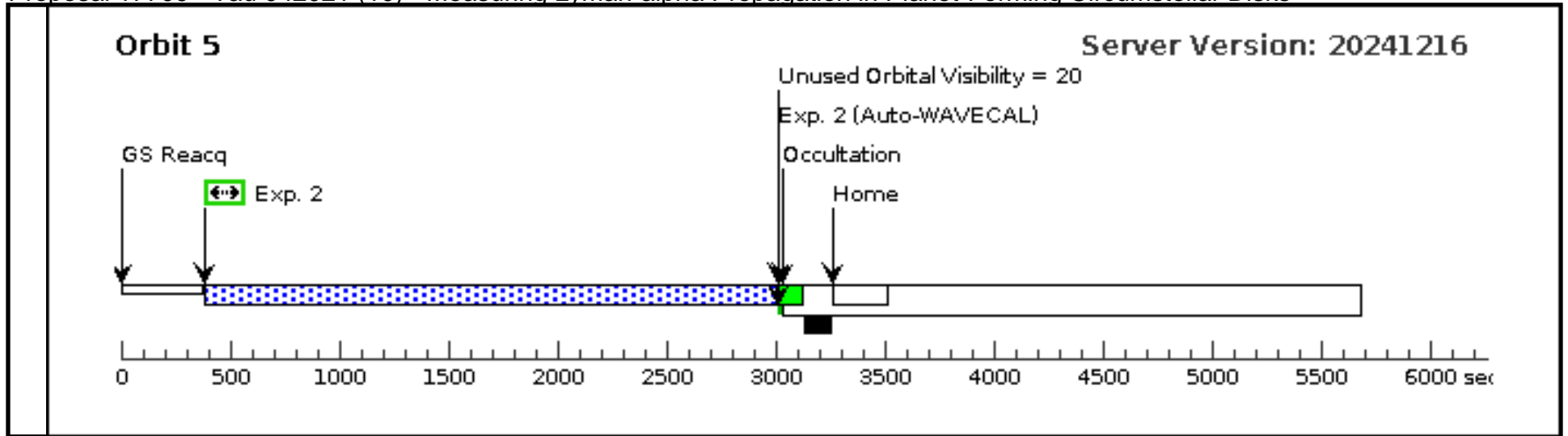

Proposal 17709 - Tau 042021 (12) - Measuring Lyman-alpha Propagation in Planet-Forming Circumstellar Disks

Tue Mar 18 18:00:22 GMT 2025

<b>Visit</b>	<b>Proposal 17709, Tau 042021 (12), implementation</b> <b>Diagnostic Status: No Diagnostics</b> Scientific Instruments: STIS/CCD, STIS/FUV-MAMA Special Requirements: (none)									
	<b>Patterns</b>	<b>#</b>	<b>Primary Pattern</b>				<b>Secondary Pattern</b>			<b>Exposures</b>
(4)		Pattern Type=STIS-PERP-TO-SLIT		Coordinate Frame=POS-TARG					(2)	
<b>Fixed Targets</b>	<b>#</b>	<b>Name</b>	<b>Target Coordinates</b>		<b>Targ. Coord. Corrections</b>		<b>Fluxes</b>	<b>Miscellaneous</b>		
	(6)	2MASS-J04202144+2813491	RA: 04 20 21.4428 (65.0893450d) Dec: +28 13 49.17 (28.23032d) Equinox: J2000		Epoch of Position: 2000		V=18.5	Reference Frame: ICRS		
Comments: This object was generated by the targetselector and retrieved from the SIMBAD database. Category=STAR Description=[PROTOPLANETARY DISK, T TAURI STAR]										
<b>Exposures</b>	<b>#</b>	<b>Label (ETC Run)</b>	<b>Target</b>	<b>Config,Mode,Aperture</b>	<b>Spectral Els.</b>	<b>Opt. Params.</b>	<b>Special Reqs.</b>	<b>Groups</b>	<b>Exp. Time (Total)/[Actual Dur.]</b>	<b>Orbit</b>
	1	Tau 042021 Target Acquisition (STIS.ta.1954484)	(6) 2MASS-J04202144+2813491	STIS/CCD, ACQ, F28X50LP	MIRROR				23 Secs (23 Secs)	
									[==>]	[1]
	2	(STIS.sp.1919521)	(6) 2MASS-J04202144+2813491	STIS/FUV-MAMA, ACCUM, 52X0.2	G140M 1222 A			Pattern 4, Exps 2-2 in Tau 042021 (12) (4)	4077 Secs (4594 Secs)	
								[==>1995 Secs (Pattern 1)]	[1]	
								[==>2599.0 Secs (Pattern 2)]	[2]	

