



18015 - Feedback by the Many or the Few? Surveying Star Cluster Outflows in NGC 4449

Cycle: 33, Proposal Category: GO
(Availability Mode: SUPPORTED)

INVESTIGATORS

<i>Name</i>	<i>Institution</i>
Dr. Erin Boettcher (PI) (Contact)	University of Maryland
Dr. Edmund Hodges-Kluck (CoI)	NASA Goddard Space Flight Center
Mainak Singha (CoI)	Catholic University of America
Dr. Mihoko Yukita (CoI)	The Johns Hopkins University

VISITS

<i>Visit</i>	<i>Targets used in Visit</i>	<i>Configurations used in Visit</i>	<i>Orbits Used</i>	<i>Last Orbit Planner Run</i>	<i>OP Current with Visit?</i>
01	(1) NGC4449-SC1	COS/FUV COS/NUV	2	14-Aug-2025 17:00:35.0	yes
02	(2) NGC4449-SC2	COS/FUV COS/NUV	1	14-Aug-2025 17:00:36.0	yes
03	(3) NGC4449-SC3	COS/FUV COS/NUV	2	14-Aug-2025 17:00:38.0	yes
04	(4) NGC4449-SC4	COS/FUV COS/NUV	3	14-Aug-2025 17:00:39.0	yes
05	(5) NGC4449-SC5	COS/FUV COS/NUV	4	14-Aug-2025 17:00:41.0	yes

<i>Visit</i>	<i>Targets used in Visit</i>	<i>Configurations used in Visit</i>	<i>Orbits Used</i>	<i>Last Orbit Planner Run</i>	<i>OP Current with Visit?</i>
06	(6) NGC4449-SC6	COS/FUV COS/NUV	3	14-Aug-2025 17:00:42.0	yes
07	(6) NGC4449-SC6	COS/FUV COS/NUV	3	14-Aug-2025 17:00:45.0	yes
08	(7) NGC4449-SC7	COS/FUV COS/NUV	4	14-Aug-2025 17:00:46.0	yes
09	(7) NGC4449-SC7	COS/FUV COS/NUV	4	14-Aug-2025 17:00:48.0	yes
10	(8) NGC4449-SC8	COS/FUV COS/NUV	1	14-Aug-2025 17:00:49.0	yes
11	(9) NGC4449-SC9	COS/FUV COS/NUV	1	14-Aug-2025 17:00:50.0	yes
12	(10) NGC4449-SC10	COS/FUV COS/NUV	1	14-Aug-2025 17:00:51.0	yes
13	(11) NGC4449-SC11	COS/FUV COS/NUV	1	14-Aug-2025 17:00:52.0	yes

30 Total Orbits Used

ABSTRACT

Star clusters are the primary purveyors of stellar feedback in starforming galaxies. Supernovae and stellar winds that are correlated in space and time thermalize their energy to produce hot, expanding bubbles of $T \sim 10^7$ K gas. When these bubbles merge with others, they can break out of the disk, powering galactic fountains and winds. In starburst galaxies, the star cluster population collaborates to drive kiloparsec-scale outflows. However, how this collaboration occurs remains unclear. It is not known whether galactic winds are driven predominantly by a small number of high-mass clusters ($\log(M/M_{\text{sun}}) \geq 4.5$) or by the combined contributions of many lower mass clusters ($3 < \log(M/M_{\text{sun}}) < 4.5$). We propose to answer this question in the nearby dwarf starburst galaxy NGC 4449 ($d = 4$ Mpc), where we will survey the warm ionized outflows associated with 12 star clusters (11 new and one archival) with $3.4 \leq \log(M/M_{\text{sun}}) \leq 5.4$ using "down-the-barrel" COS/G130M spectroscopy. We will measure the metal column densities, traced by $N(\text{Si}) = N(\text{SiII}) + N(\text{SiIII}) + N(\text{SiIV})$, as a function of velocity to constrain the energy and metal mass engaged in galactic fountains ($v < v_{\text{esc}}$) and winds ($v > v_{\text{esc}}$) as a function of cluster mass. By quantifying the role of lower mass clusters in driving starburst winds,

we will determine the dominant drivers of the large-scale outflows that heat and chemically enrich the circumgalactic and intergalactic medium.

OBSERVING DESCRIPTION

We propose a COS FUV survey of warm outflows from 11 young, massive star clusters across the nearby dwarf starburst galaxy NGC 4449 ($D = 4$ Mpc). The program goal is to determine the feedback contribution, or the amount of outflowing gas in winds ($v > v_{\text{esc}}$) or fountains ($v < v_{\text{esc}}$), as a function of cluster mass. We will detect the outflowing gas in absorption from low and intermediate ions against the light of the UV-bright clusters. For each cluster, we will measure the metal column densities associated with warm, diffuse outflows, as traced by the Si column density, $N(\text{Si}) = N(\text{SiII}) + N(\text{SiIII}) + N(\text{SiIV})$.

We will use COS/G130M with $\text{cenwav} = 1291$ Å to cover the SiII (1190, 1193, 1304 Å), SiIII (1206 Å), and SiIV (1393, 1402 Å) transitions. The exposure time is divided evenly between FP-POS = 3 and 4 to improve the S/N. The medium resolution grating (FWHM = 14 - 19 km/s) is needed to resolve the gas kinematics and determine the column density at $v > v_{\text{esc}}$.

To determine the exposure times, we measured the flux within the COS aperture in an archival HST/WFC3 F218W image (Program 16316, PI Sabbi) and extrapolated to the COS band with the ETC assuming a typical cluster spectral energy distribution and the total (foreground and intrinsic) $E(B - V)$ from Bradley et al. (2020). We validated our exposure time calculation by applying the same procedure to an archival COS spectrum of a star cluster in NGC 4449. We require $S/N = 10$ at SiIV 1393, 1402 to measure the column density and the velocities to the required precision. This criterion ensures $S/N > 10$ at SiII and SiIII. This yields total exposure times of $t_{\text{exp}} = 1000 - 15500$ s, or 1 - 8 orbits per sightline for a total request of 30 orbits.

All targets are faint and point-like, and thus a standard target acquisition in ACQ/IMAGE mode is most efficient. The target coordinates are well-known and have been validated using multi-band archival HST/WFC3 imaging of NGC 4449. The ETC and BOT reported no warnings for violations of the bright object limits.

Proposal 18015 - NGC4449 Cluster 1 (01) - Feedback by the Many or the Few? Surveying Star Cluster Outflows in NGC 4449

Thu Aug 14 21:00:53 GMT 2025

Visit	Proposal 18015, NGC4449_Cluster_1 (01) Diagnostic Status: No Diagnostics Scientific Instruments: COS/FUV, COS/NUV Special Requirements: (none)									
	Fixed Targets	#	Name	Target Coordinates	Targ. Coord. Corrections	Fluxes	Miscellaneous			
	(1)	NGC4449-SC1	RA: 12 28 12.9900 (187.0541250d) Dec: +44 06 11.64 (44.10323d) Equinox: J2000		V=18.8	Reference Frame: ICRS				
	<i>Comments:</i> Category=EXT-CLUSTER Description=[STAR FORMING REGION] Extended=NO									
Exposures	#	Label (ETC Run)	Target	Config,Mode,Aperture	Spectral Els.	Opt. Params.	Special Reqs.	Groups	Exp. Time (Total)/[Actual Dur.]	Orbit
	1	ACQ-NGC4449_Cluster_1 (COS.ta.2025770)	(1) NGC4449-SC1	COS/NUV, ACQ/IMAGE, PSA	MIRRORB				11.5 Secs (11.5 Secs) [==>]	[1]
	2	SCI-FP3-NGC4449_Cluster_1 (COS.sp.2025754)	(1) NGC4449-SC1	COS/FUV, TIME-TAG, PSA	G130M 1291 A	BUFFER-TIME=28 82; SEGMENT=BOTH; FP-POS=3			1425 Secs (2167 Secs) [==>2167.0 Secs]	[1]
	3	SCI-FP4-NGC4449_Cluster_1 (COS.sp.2025754)	(1) NGC4449-SC1	COS/FUV, TIME-TAG, PSA	G130M 1291 A	BUFFER-TIME=28 82; SEGMENT=BOTH; FP-POS=4			1450 Secs (2561 Secs) [==>2561.0 Secs]	[2]

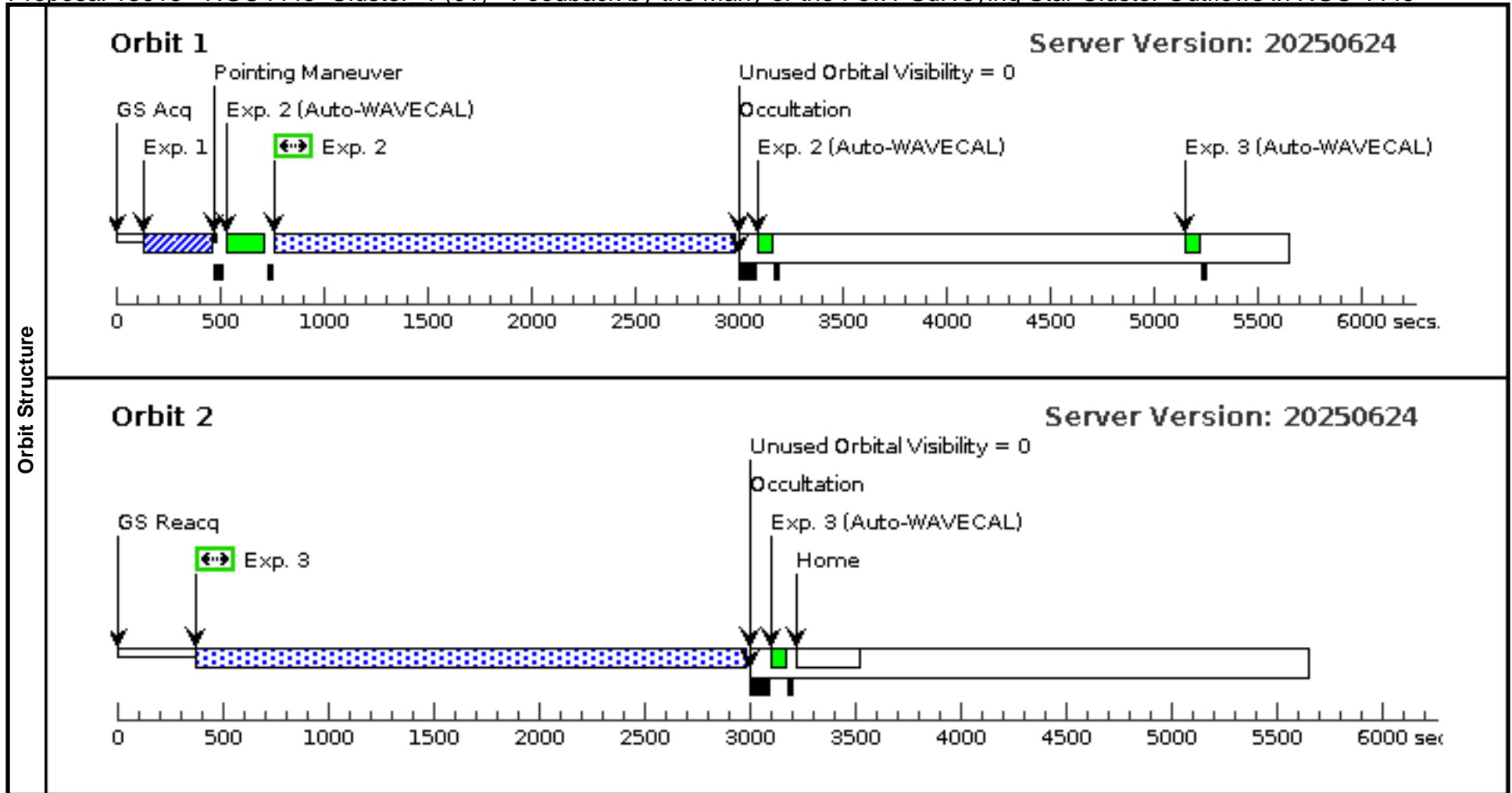

Proposal 18015 - NGC4449-Cluster 2 (02) - Feedback by the Many or the Few? Surveying Star Cluster Outflows in NGC 4449

Thu Aug 14 21:00:53 GMT 2025

Visit	Proposal 18015, NGC4449-Cluster_2 (02) Diagnostic Status: Warning Scientific Instruments: COS/FUV, COS/NUV Special Requirements: (none)									
	(NGC4449-Cluster_2 (02)) Warning (Orbit Planner): COS EXPOSURE TIME ROUNDED DOWN TO NEAREST 0.1 SECONDS									
Fixed Targets	#	Name	Target Coordinates	Targ. Coord. Corrections	Fluxes	Miscellaneous				
	(2)	NGC4449-SC2	RA: 12 28 11.9200 (187.0496667d) Dec: +44 05 57.98 (44.09944d) Equinox: J2000		V=18.8	Reference Frame: ICRS				
Comments: Category=EXT-CLUSTER Description=[STAR FORMING REGION] Extended=NO										
Exposures	#	Label (ETC Run)	Target	Config,Mode,Aperture	Spectral Els.	Opt. Params.	Special Reqs.	Groups	Exp. Time (Total)/[Actual Dur.]	Orbit
	1	ACQ-NGC4449_Cluster_2 (COS.ta.2025772)	(2) NGC4449-SC2	COS/NUV, ACQ/IMAGE, PSA	MIRRORB				7.8 Secs (7.8 Secs) [==>]	[1]
	2	SCI-FP3-N GC4449_C1 uster_2 (COS.sp.2025755)	(2) NGC4449-SC2	COS/FUV, TIME-TAG, PSA	G130M 1291 A	BUFFER-TIME=24 66; SEGMENT=BOTH; FP-POS=3			901 Secs (901 Secs) [==>]	[1]
	3	SCI-FP4-N GC4449_C1 uster_2 (COS.sp.2025755)	(2) NGC4449-SC2	COS/FUV, TIME-TAG, PSA	G130M 1291 A	BUFFER-TIME=24 66; SEGMENT=BOTH; FP-POS=4			901 Secs (901 Secs) [==>]	[1]

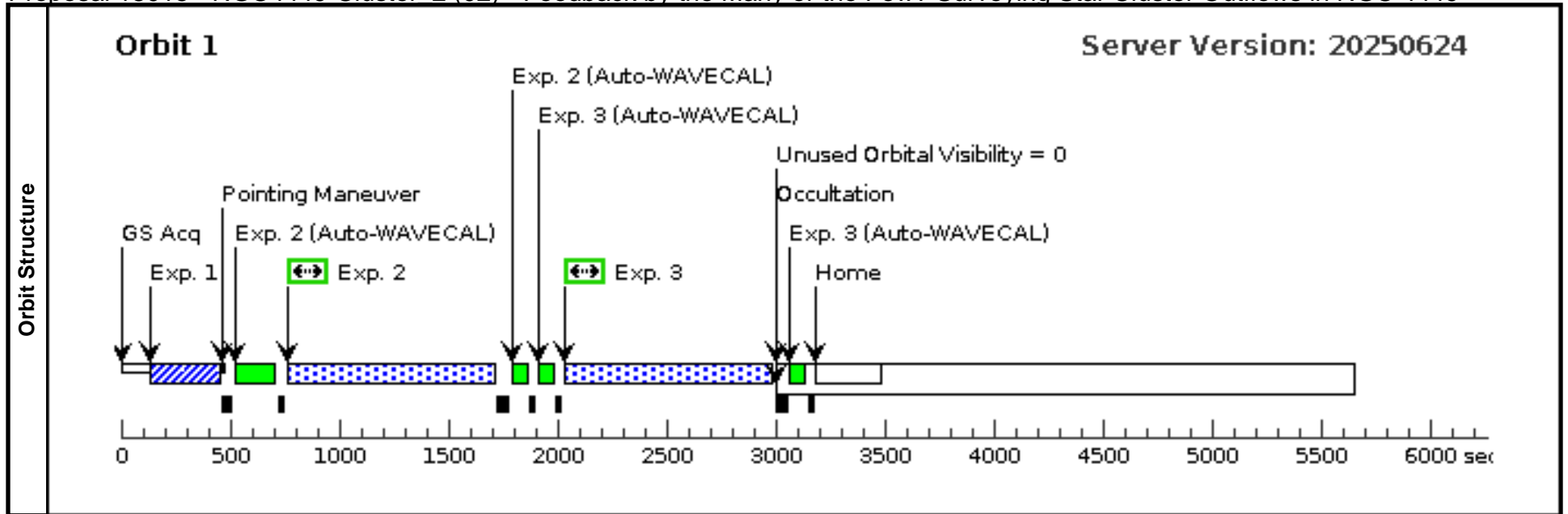

Proposal 18015 - NGC4449-Cluster 3 (03) - Feedback by the Many or the Few? Surveying Star Cluster Outflows in NGC 4449

Thu Aug 14 21:00:53 GMT 2025

Visit	Proposal 18015, NGC4449-Cluster_3 (03) Diagnostic Status: Warning Scientific Instruments: COS/FUV, COS/NUV Special Requirements: (none)									
	(NGC4449-Cluster_3 (03)) Warning (Orbit Planner): COS EXPOSURE TIME ROUNDED DOWN TO NEAREST 0.1 SECONDS									
Fixed Targets	#	Name	Target Coordinates	Targ. Coord. Corrections	Fluxes	Miscellaneous				
	(3)	NGC4449-SC3	RA: 12 28 13.2900 (187.0553750d) Dec: +44 05 5.87 (44.08496d) Equinox: J2000		V=18.7	Reference Frame: ICRS				
Comments: Category=EXT-CLUSTER Description=[STAR FORMING REGION] Extended=NO										
Exposures	#	Label (ETC Run)	Target	Config,Mode,Aperture	Spectral Els.	Opt. Params.	Special Reqs.	Groups	Exp. Time (Total)/[Actual Dur.]	Orbit
	1	ACQ-NGC4449_Cluster_3 (COS.ta.2025774)	(3) NGC4449-SC3	COS/NUV, ACQ/IMAGE, PSA	MIRRORB				15.1 Secs (15.1 Secs) [==>]	[1]
	2	SCI-FP3-N GC4449_C1 uster_3 (COS.sp.2025759)	(3) NGC4449-SC3	COS/FUV, TIME-TAG, PSA	G130M 1291 A	BUFFER-TIME=29 99; SEGMENT=BOTH; FP-POS=3			1700 Secs (2159 Secs) [==>2159.0 Secs]	[1]
	3	SCI-FP4-N GC4449_C1 uster_3 (COS.sp.2025759)	(3) NGC4449-SC3	COS/FUV, TIME-TAG, PSA	G130M 1291 A	BUFFER-TIME=29 99; SEGMENT=BOTH; FP-POS=4			1700 Secs (2561 Secs) [==>2561.0 Secs]	[2]

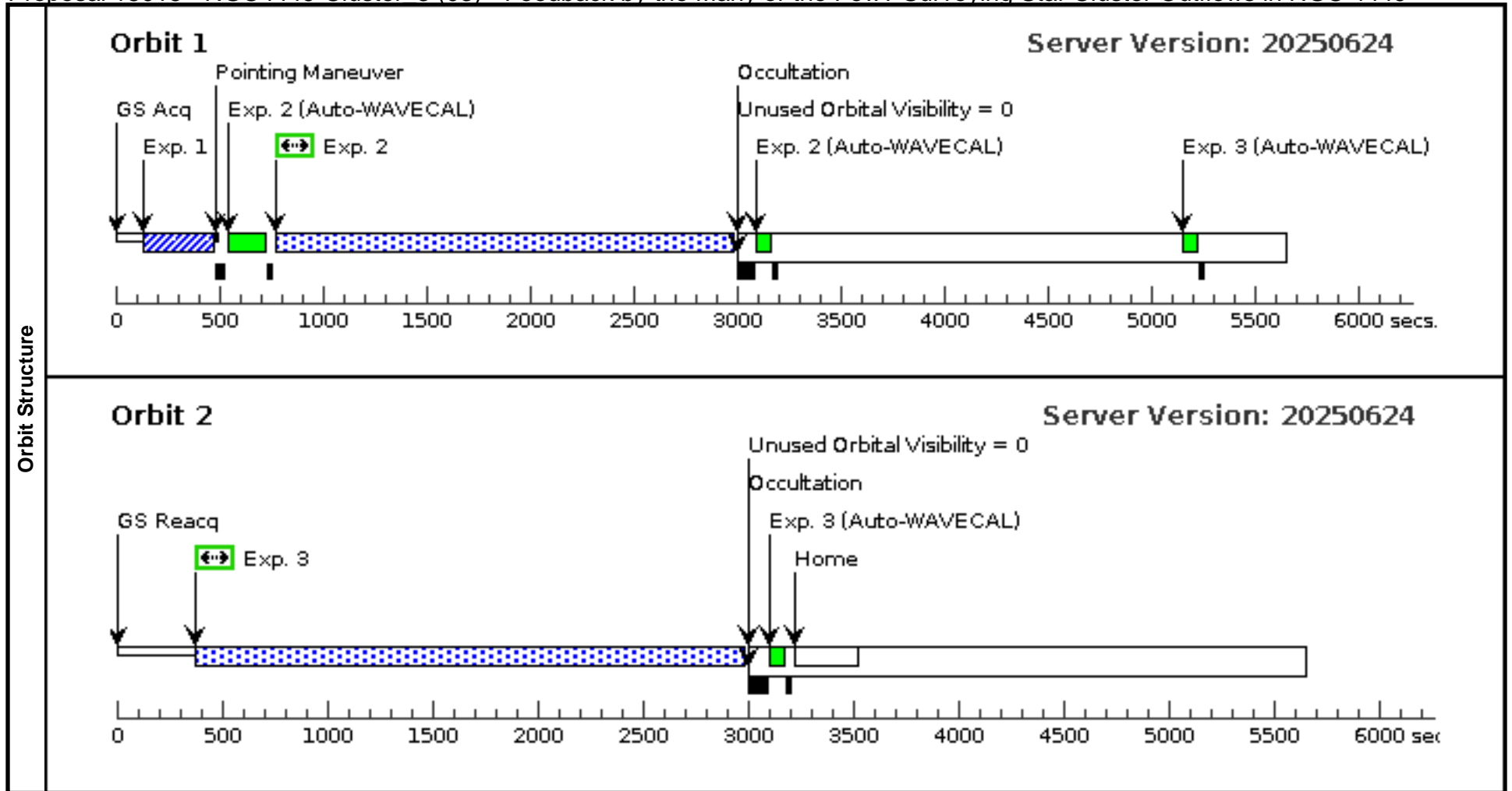

Proposal 18015 - NGC4449-Cluster 4 (04) - Feedback by the Many or the Few? Surveying Star Cluster Outflows in NGC 4449

Thu Aug 14 21:00:53 GMT 2025

Visit	Proposal 18015, NGC4449-Cluster_4 (04) Diagnostic Status: No Diagnostics Scientific Instruments: COS/FUV, COS/NUV Special Requirements: (none)									
	Fixed Targets	#	Name	Target Coordinates	Targ. Coord. Corrections	Fluxes	Miscellaneous			
		(4)	NGC4449-SC4	RA: 12 28 11.5300 (187.0480417d) Dec: +44 05 56.98 (44.09916d) Equinox: J2000		V=19.3	Reference Frame: ICRS			
	<i>Comments:</i> Category=EXT-CLUSTER Description=[STAR FORMING REGION] Extended=NO									
Exposures	#	Label (ETC Run)	Target	Config,Mode,Aperture	Spectral Els.	Opt. Params.	Special Reqs.	Groups	Exp. Time (Total)/[Actual Dur.]	Orbit
	1	ACQ-NGC4449_Cluster_4 (COS.ta.2025775)	(4) NGC4449-SC4	COS/NUV, ACQ/IMAGE, PSA	MIRRORA				1.3 Secs (1.3 Secs) [==>]	[1]
	2	SCI-FP3-NGC4449_Cluster_4 (COS.sp.2025757)	(4) NGC4449-SC4	COS/FUV, TIME-TAG, PSA	G130M 1291 A	BUFFER-TIME=3303; SEGMENT=BOTH; FP-POS=3			1700 Secs (2187 Secs) [==>2187.0 Secs]	[1]
	3	SCI-FP3-NGC4449_Cluster_4 (COS.sp.2025757)	(4) NGC4449-SC4	COS/FUV, TIME-TAG, PSA	G130M 1291 A	BUFFER-TIME=3303; SEGMENT=BOTH; FP-POS=3			1100 Secs (1099 Secs) [==>1099.0 Secs]	[2]
	4	SCI-FP4-NGC4449_Cluster_4 (COS.sp.2025757)	(4) NGC4449-SC4	COS/FUV, TIME-TAG, PSA	G130M 1291 A	BUFFER-TIME=3303; SEGMENT=BOTH; FP-POS=4			1100 Secs (1099 Secs) [==>1099.0 Secs]	[2]
	5	SCI-FP4-NGC4449_Cluster_4 (COS.sp.2025757)	(4) NGC4449-SC4	COS/FUV, TIME-TAG, PSA	G130M 1291 A	BUFFER-TIME=3303; SEGMENT=BOTH; FP-POS=4			2100 Secs (2561 Secs) [==>2561.0 Secs]	[3]

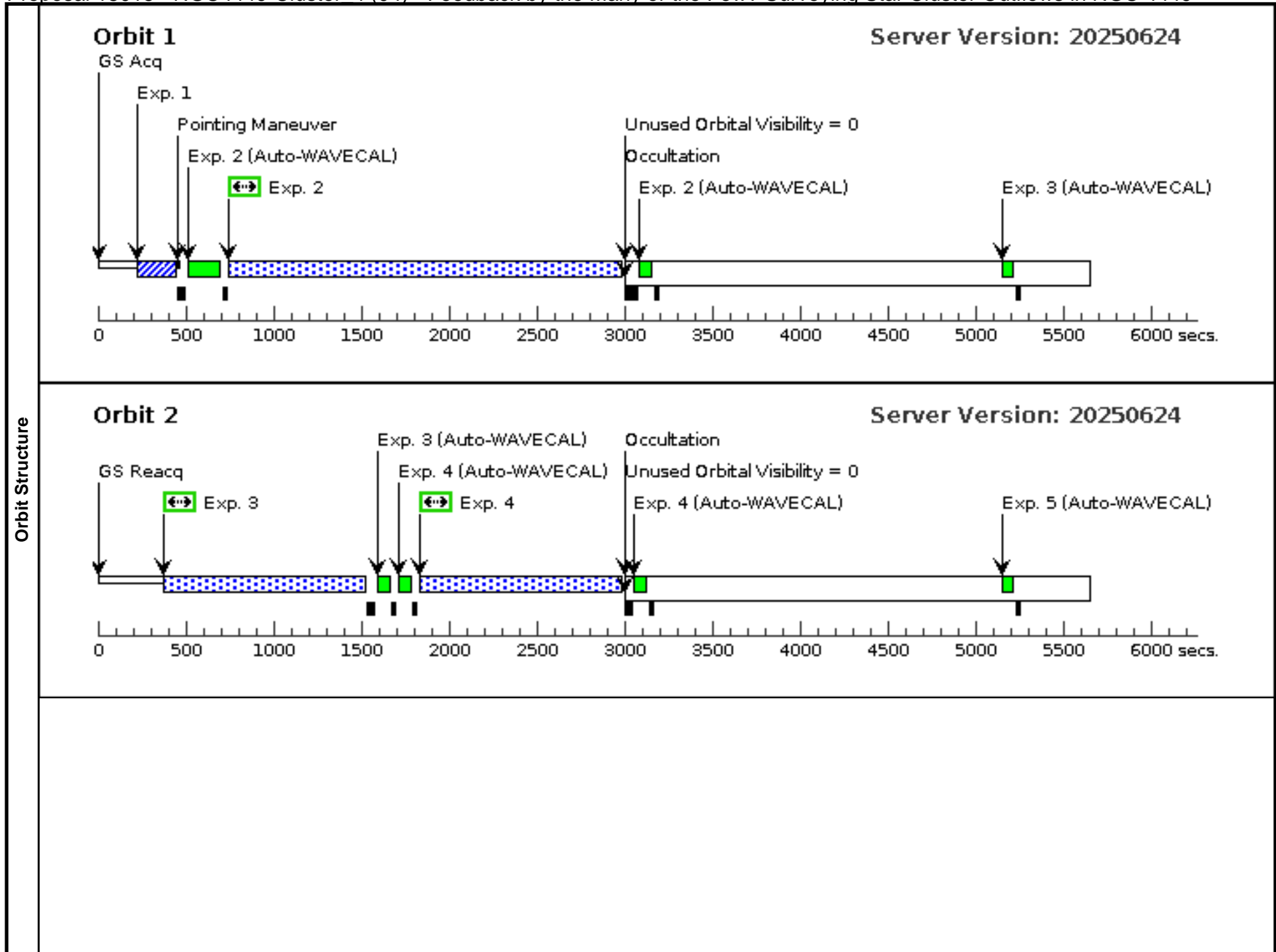

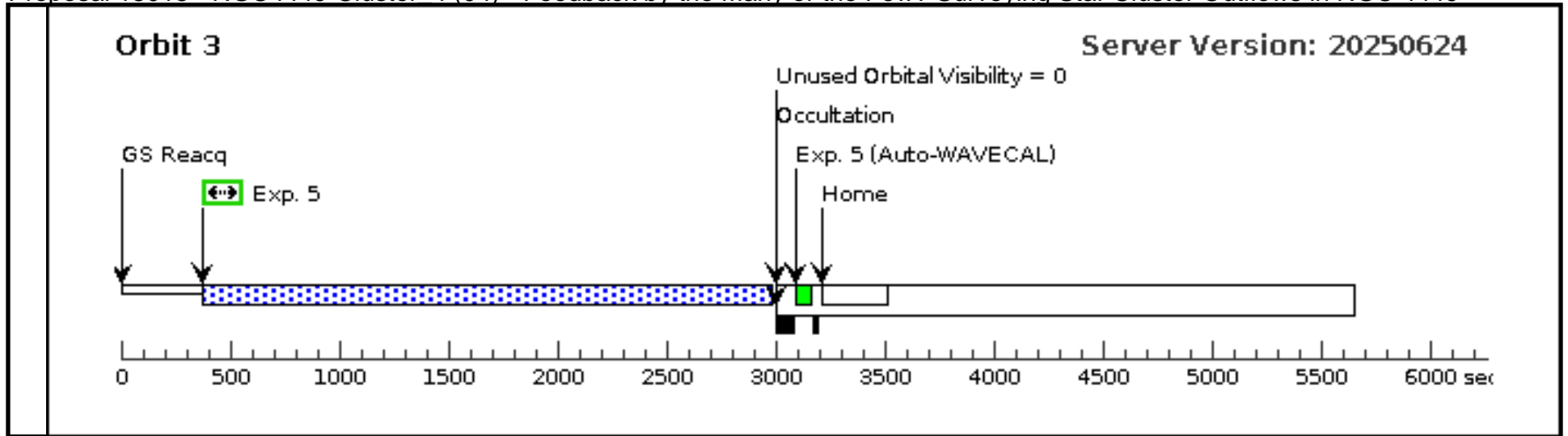

Proposal 18015 - NGC4449 Cluster 5 (05) - Feedback by the Many or the Few? Surveying Star Cluster Outflows in NGC 4449

Thu Aug 14 21:00:53 GMT 2025

Visit	Proposal 18015, NGC4449_Cluster_5 (05) Diagnostic Status: No Diagnostics Scientific Instruments: COS/FUV, COS/NUV Special Requirements: (none)									
	Fixed Targets	#	Name	Target Coordinates	Targ. Coord. Corrections	Fluxes	Miscellaneous			
	(5)	NGC4449-SC5	RA: 12 28 11.3000 (187.0470833d) Dec: +44 05 44.23 (44.09562d) Equinox: J2000		V=20.2	Reference Frame: ICRS				
	<i>Comments:</i> Category=EXT-CLUSTER Description=[STAR FORMING REGION] Extended=NO									
Exposures	#	Label (ETC Run)	Target	Config,Mode,Aperture	Spectral Els.	Opt. Params.	Special Reqs.	Groups	Exp. Time (Total)/[Actual Dur.]	Orbit
	1	ACQ-NGC4449_Cluster_5 (COS.ta.2025776)	(5) NGC4449-SC5	COS/NUV, ACQ/IMAGE, PSA	MIRRORA				2.1 Secs (2.1 Secs) [==>]	[1]
	2	SCI-FP3-NGC4449_Cluster_5 (COS.sp.2025760)	(5) NGC4449-SC5	COS/FUV, TIME-TAG, PSA	G130M 1291 A	BUFFER-TIME=35 23; SEGMENT=BOTH; FP-POS=3			1425 Secs (2185 Secs) [==>2185.0 Secs]	[1]
	3	SCI-FP3-NGC4449_Cluster_5 (COS.sp.2025760)	(5) NGC4449-SC5	COS/FUV, TIME-TAG, PSA	G130M 1291 A	BUFFER-TIME=35 23; SEGMENT=BOTH; FP-POS=3			1425 Secs (2561 Secs) [==>2561.0 Secs]	[2]
	4	SCI-FP4-NGC4449_Cluster_5 (COS.sp.2025760)	(5) NGC4449-SC5	COS/FUV, TIME-TAG, PSA	G130M 1291 A	BUFFER-TIME=35 23; SEGMENT=BOTH; FP-POS=4			1450 Secs (2561 Secs) [==>2561.0 Secs]	[3]
	5	SCI-FP4-NGC4449_Cluster_5 (COS.sp.2025760)	(5) NGC4449-SC5	COS/FUV, TIME-TAG, PSA	G130M 1291 A	BUFFER-TIME=35 23; SEGMENT=BOTH; FP-POS=4			1450 Secs (2561 Secs) [==>2561.0 Secs]	[4]

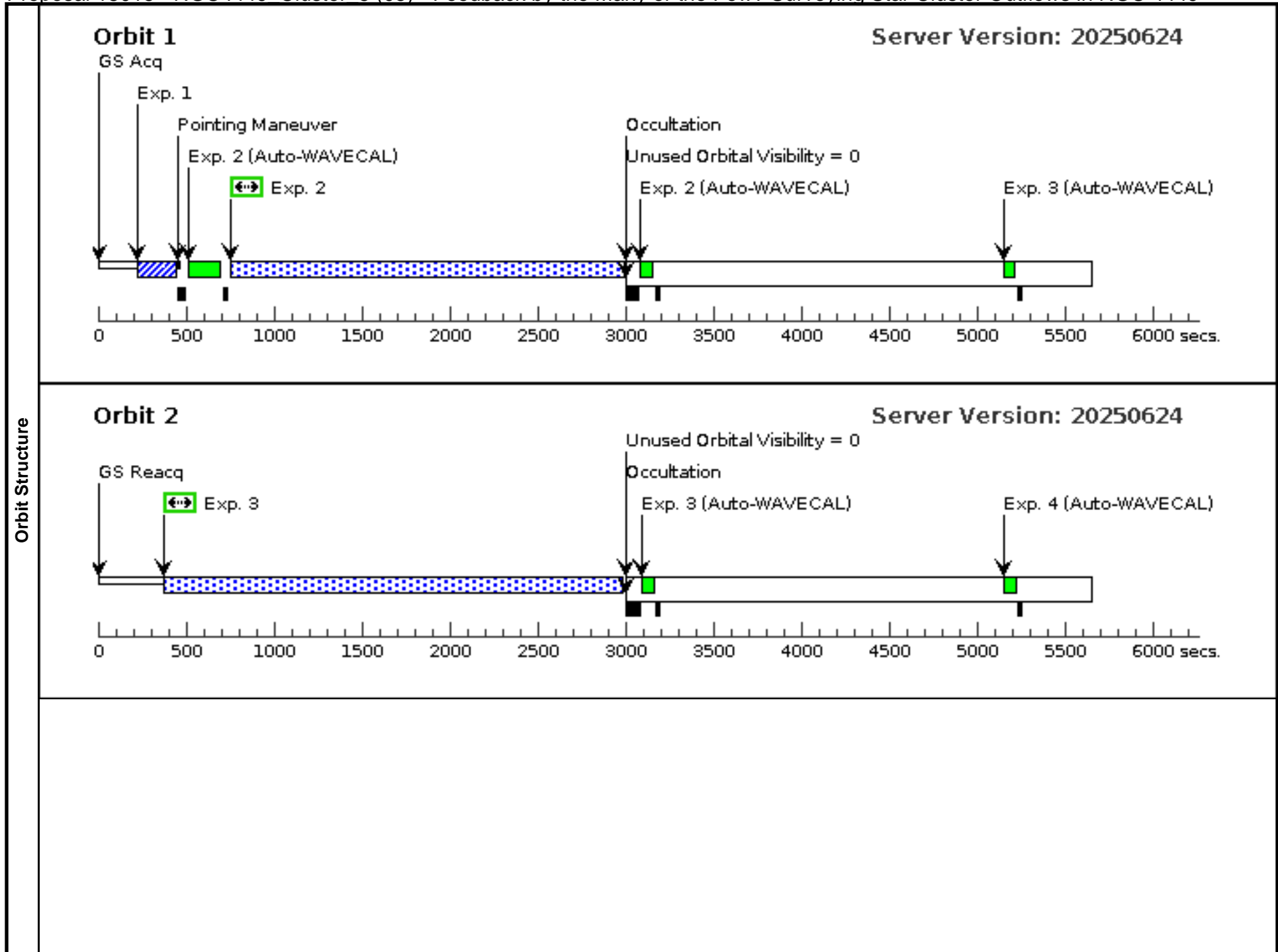

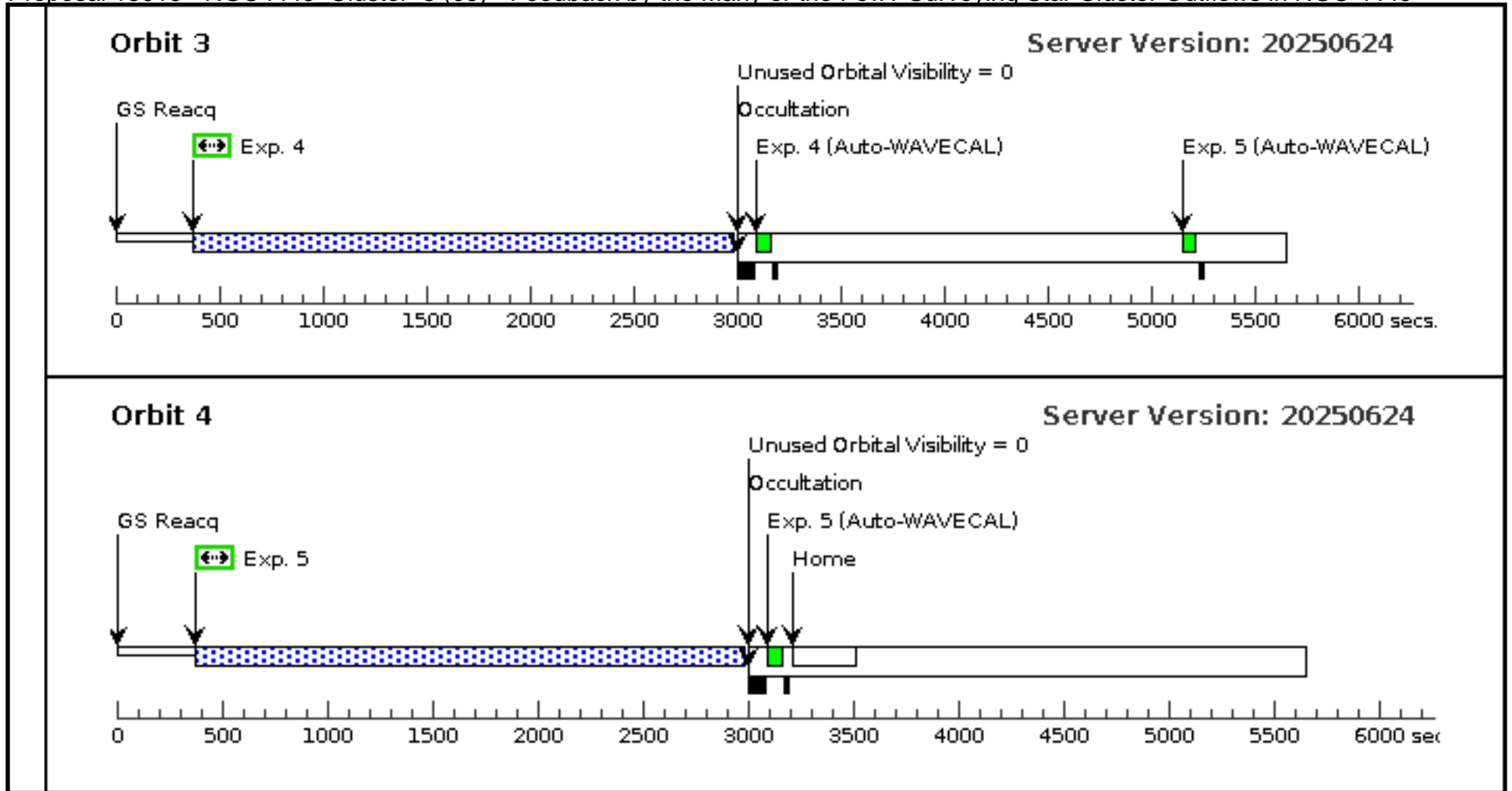

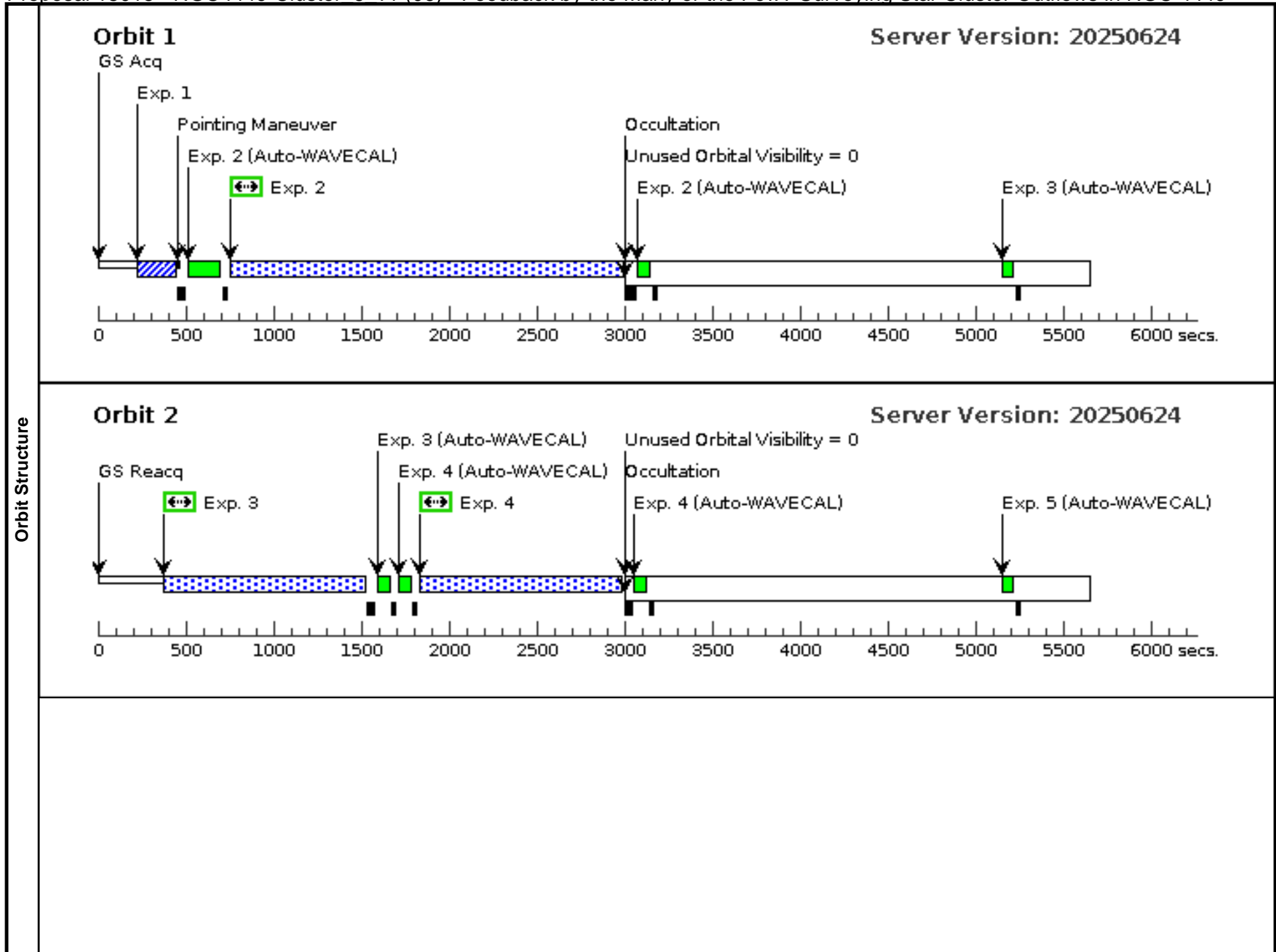

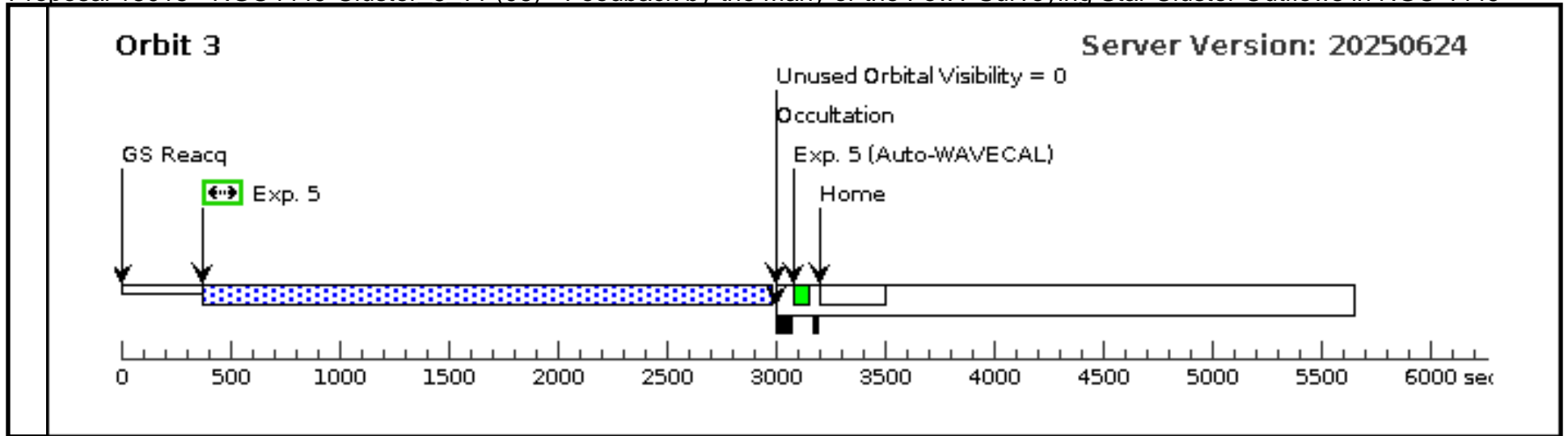

Proposal 18015 - NGC4449-Cluster 6 v2 (07) - Feedback by the Many or the Few? Surveying Star Cluster Outflows in NGC 4449

Thu Aug 14 21:00:53 GMT 2025

Visit	Proposal 18015, NGC4449-Cluster_6_v2 (07) Diagnostic Status: No Diagnostics Scientific Instruments: COS/FUV, COS/NUV Special Requirements: (none)									
	Fixed Targets	#	Name	Target Coordinates	Targ. Coord. Corrections	Fluxes	Miscellaneous			
		(6)	NGC4449-SC6	RA: 12 28 9.9900 (187.0416250d) Dec: +44 05 24.53 (44.09015d) Equinox: J2000		V=20.3	Reference Frame: ICRS			
	<i>Comments:</i> Category=EXT-CLUSTER Description=[STAR FORMING REGION] Extended=NO									
Exposures	#	Label (ETC Run)	Target	Config,Mode,Aperture	Spectral Els.	Opt. Params.	Special Reqs.	Groups	Exp. Time (Total)/[Actual Dur.]	Orbit
	1	ACQ-NGC4449_Cluster_6_v2 (COS.ta.2025777)	(6) NGC4449-SC6	COS/NUV, ACQ/IMAGE, PSA	MIRRORA				2.1 Secs (2.1 Secs) [==>]	[1]
	2	SCI-FP3-NGC4449_Cluster_6_v2 (COS.sp.2025761)	(6) NGC4449-SC6	COS/FUV, TIME-TAG, PSA	G130M 1291 A	BUFFER-TIME=41 76; SEGMENT=BOTH; FP-POS=3			1700 Secs (2185 Secs) [==>2185.0 Secs]	[1]
	3	SCI-FP3-NGC4449_Cluster_6_v2 (COS.sp.2025761)	(6) NGC4449-SC6	COS/FUV, TIME-TAG, PSA	G130M 1291 A	BUFFER-TIME=41 76; SEGMENT=BOTH; FP-POS=3			1100 Secs (1099 Secs) [==>1099.0 Secs]	[2]
	4	SCI-FP4-NGC4449_Cluster_6_v2 (COS.sp.2025761)	(6) NGC4449-SC6	COS/FUV, TIME-TAG, PSA	G130M 1291 A	BUFFER-TIME=41 76; SEGMENT=BOTH; FP-POS=4			1100 Secs (1099 Secs) [==>1099.0 Secs]	[2]
	5	SCI-FP4-NGC4449_Cluster_6_v2 (COS.sp.2025761)	(6) NGC4449-SC6	COS/FUV, TIME-TAG, PSA	G130M 1291 A	BUFFER-TIME=41 76; SEGMENT=BOTH; FP-POS=4			2100 Secs (2561 Secs) [==>2561.0 Secs]	[3]

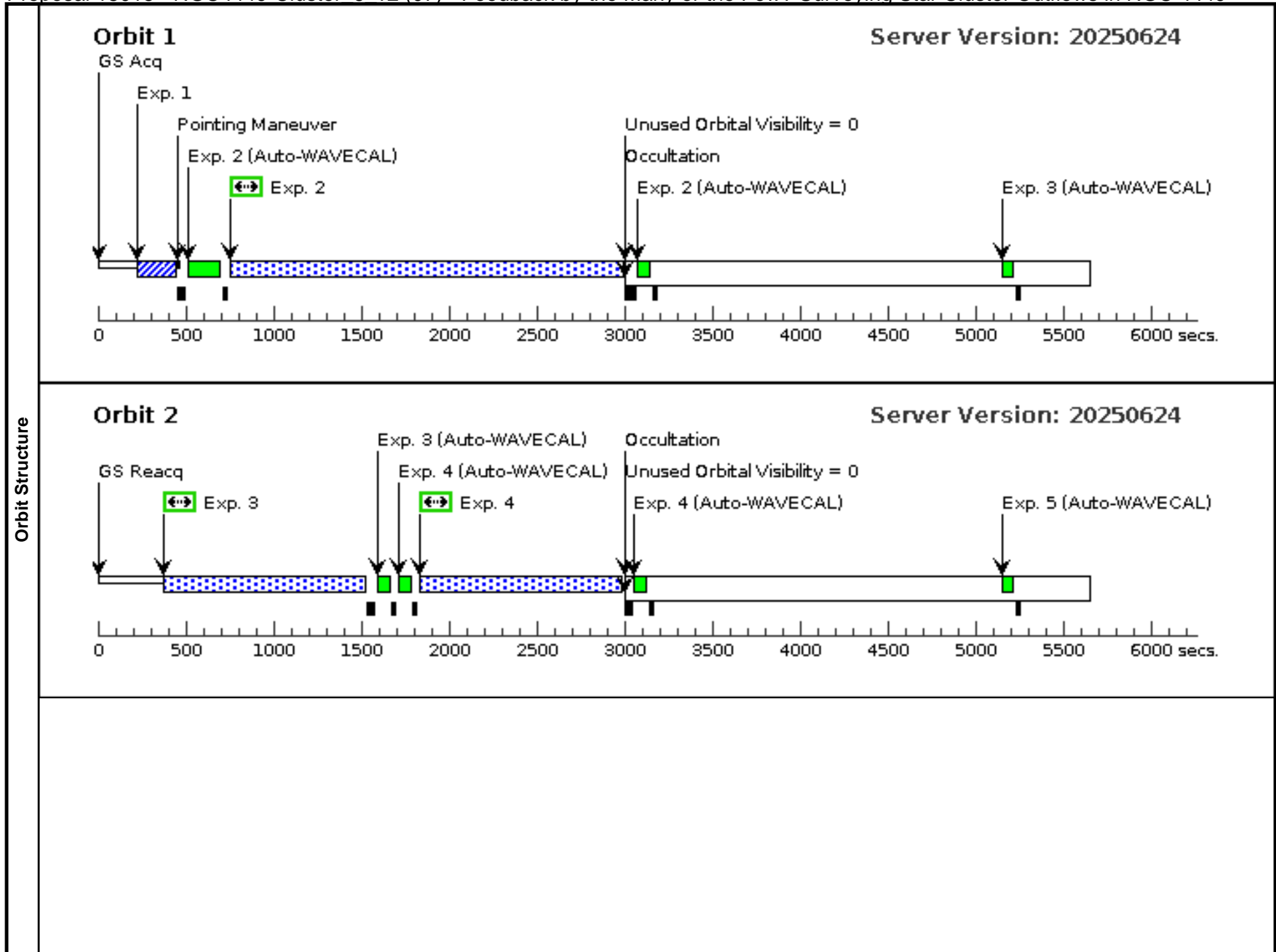

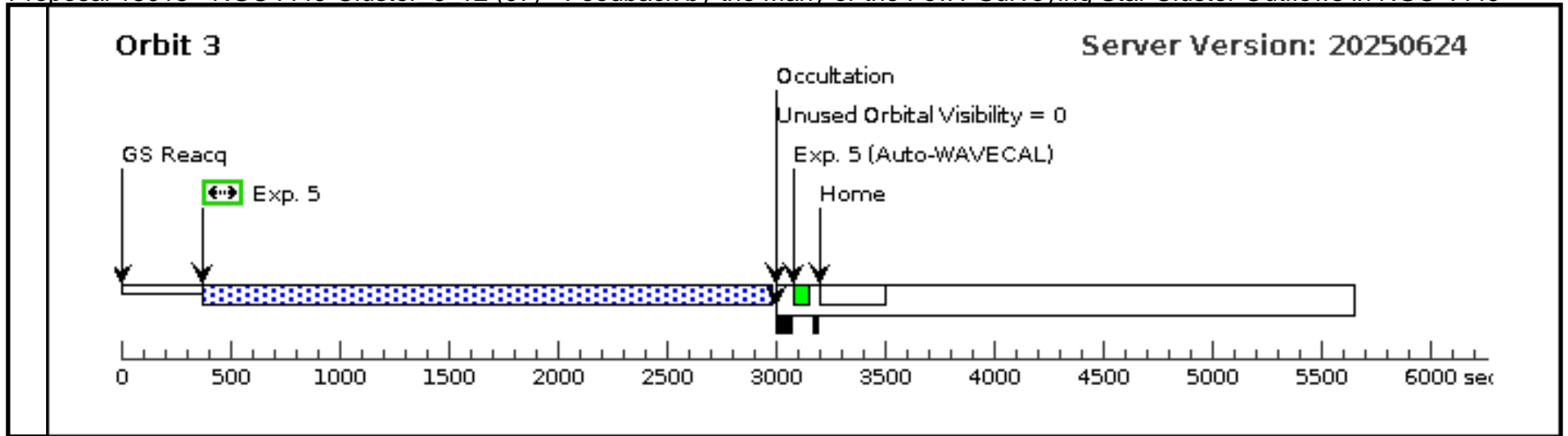

Proposal 18015 - NGC4449 Cluster 7 v1 (08) - Feedback by the Many or the Few? Surveying Star Cluster Outflows in NGC 4449

Thu Aug 14 21:00:53 GMT 2025

Visit	Proposal 18015, NGC4449_Cluster_7_v1 (08) Diagnostic Status: No Diagnostics Scientific Instruments: COS/FUV, COS/NUV Special Requirements: (none)									
	Fixed Targets	#	Name	Target Coordinates	Targ. Coord. Corrections	Fluxes	Miscellaneous			
		(7)	NGC4449-SC7	RA: 12 28 12.9200 (187.0538333d) Dec: +44 05 33.06 (44.09252d) Equinox: J2000		V=20.8	Reference Frame: ICRS			
	<i>Comments:</i> Category=EXT-CLUSTER Description=[STAR FORMING REGION] Extended=NO									
Exposures	#	Label (ETC Run)	Target	Config,Mode,Aperture	Spectral Els.	Opt. Params.	Special Reqs.	Groups	Exp. Time (Total)/[Actual Dur.]	Orbit
	1	ACQ-NGC4449_Cluster_7_v1 (COS.ta.2025779)	(7) NGC4449-SC7	COS/NUV, ACQ/IMAGE, PSA	MIRRORA				4.2 Secs (4.2 Secs) [==>]	[1]
	2	SCI-FP3-N GC4449_Cluster_7_v1 (COS.sp.2025762)	(7) NGC4449-SC7	COS/FUV, TIME-TAG, PSA	G130M 1291 A	BUFFER-TIME=40 33; SEGMENT=BOTH; FP-POS=3			1425 Secs (2181 Secs) [==>2181.0 Secs]	[1]
	3	SCI-FP3-N GC4449_Cluster_7_v1 (COS.sp.2025762)	(7) NGC4449-SC7	COS/FUV, TIME-TAG, PSA	G130M 1291 A	BUFFER-TIME=40 33; SEGMENT=BOTH; FP-POS=3			1425 Secs (2561 Secs) [==>2561.0 Secs]	[2]
	4	SCI-FP4-N GC4449_Cluster_7_v1 (COS.sp.2025762)	(7) NGC4449-SC7	COS/FUV, TIME-TAG, PSA	G130M 1291 A	BUFFER-TIME=40 33; SEGMENT=BOTH; FP-POS=4			1450 Secs (2561 Secs) [==>2561.0 Secs]	[3]
	5	SCI-FP4-N GC4449_Cluster_7_v1 (COS.sp.2025762)	(7) NGC4449-SC7	COS/FUV, TIME-TAG, PSA	G130M 1291 A	BUFFER-TIME=40 33; SEGMENT=BOTH; FP-POS=4			1450 Secs (2561 Secs) [==>2561.0 Secs]	[4]

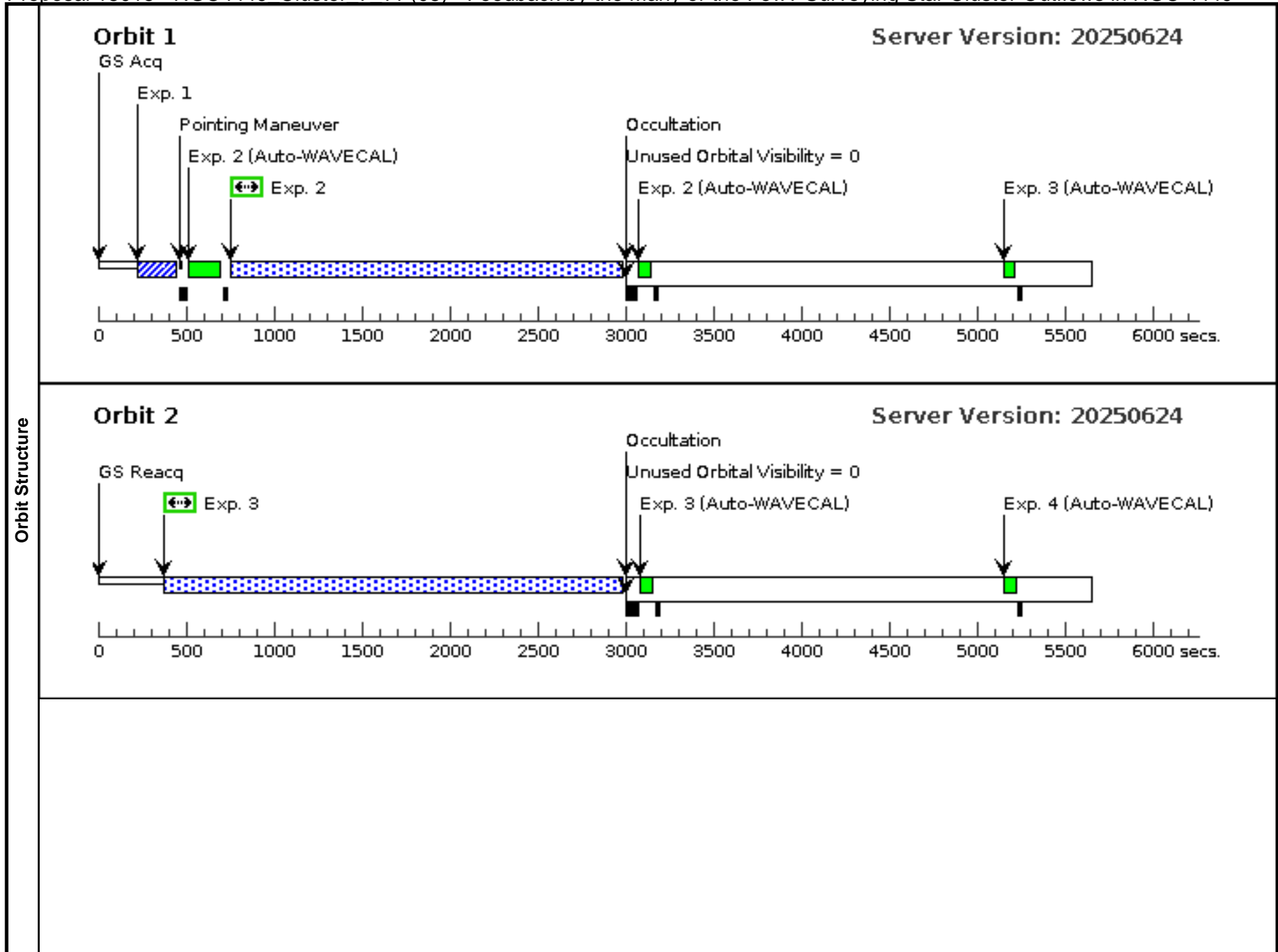

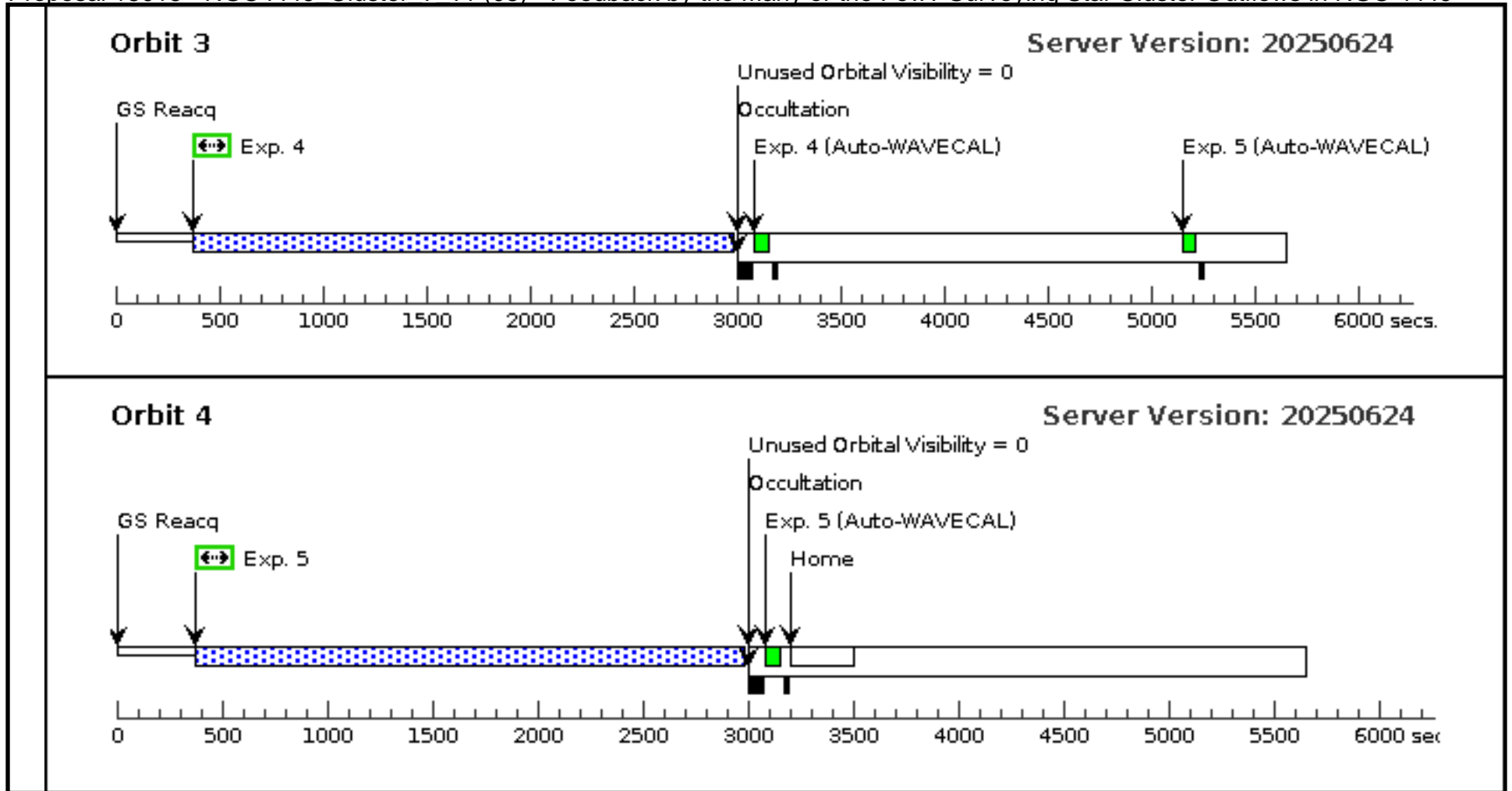

Proposal 18015 - NGC4449 Cluster 7 v2 (09) - Feedback by the Many or the Few? Surveying Star Cluster Outflows in NGC 4449

Thu Aug 14 21:00:53 GMT 2025

Visit	Proposal 18015, NGC4449_Cluster_7_v2 (09) Diagnostic Status: No Diagnostics Scientific Instruments: COS/FUV, COS/NUV Special Requirements: (none)												
	Fixed Targets	<table border="1"> <thead> <tr> <th>#</th> <th>Name</th> <th>Target Coordinates</th> <th>Targ. Coord. Corrections</th> <th>Fluxes</th> <th>Miscellaneous</th> </tr> </thead> <tbody> <tr> <td>(7)</td> <td>NGC4449-SC7</td> <td>RA: 12 28 12.9200 (187.0538333d) Dec: +44 05 33.06 (44.09252d) Equinox: J2000</td> <td></td> <td>V=20.8</td> <td>Reference Frame: ICRS</td> </tr> </tbody> </table> <p><i>Comments:</i> Category=<i>EXT-CLUSTER</i> Description=<i>[STAR FORMING REGION]</i> Extended=<i>NO</i></p>	#	Name	Target Coordinates	Targ. Coord. Corrections	Fluxes	Miscellaneous	(7)	NGC4449-SC7	RA: 12 28 12.9200 (187.0538333d) Dec: +44 05 33.06 (44.09252d) Equinox: J2000		V=20.8
#	Name	Target Coordinates	Targ. Coord. Corrections	Fluxes	Miscellaneous								
(7)	NGC4449-SC7	RA: 12 28 12.9200 (187.0538333d) Dec: +44 05 33.06 (44.09252d) Equinox: J2000		V=20.8	Reference Frame: ICRS								
Exposures	#	Label (ETC Run)	Target	Config,Mode,Aperture	Spectral Els.	Opt. Params.	Special Reqs.	Groups	Exp. Time (Total)/[Actual Dur.]	Orbit			
	1	ACQ-NGC4449_Cluster_7_v2 (COS.ta.2025779)	(7) NGC4449-SC7	COS/NUV, ACQ/IMAGE, PSA	MIRRORA				4.2 Secs (4.2 Secs) [==>]	[1]			
	2	SCI-FP3-NGC4449_Cluster_7_v2 (COS.sp.2025762)	(7) NGC4449-SC7	COS/FUV, TIME-TAG, PSA	G130M 1291 A	BUFFER-TIME=40 33; SEGMENT=BOTH; FP-POS=3			1425 Secs (2181 Secs) [==>2181.0 Secs]	[1]			
	3	SCI-FP3-NGC4449_Cluster_7_v2 (COS.sp.2025762)	(7) NGC4449-SC7	COS/FUV, TIME-TAG, PSA	G130M 1291 A	BUFFER-TIME=40 33; SEGMENT=BOTH; FP-POS=3			1425 Secs (2561 Secs) [==>2561.0 Secs]	[2]			
	4	SCI-FP4-NGC4449_Cluster_7_v2 (COS.sp.2025762)	(7) NGC4449-SC7	COS/FUV, TIME-TAG, PSA	G130M 1291 A	BUFFER-TIME=40 33; SEGMENT=BOTH; FP-POS=4			1450 Secs (2561 Secs) [==>2561.0 Secs]	[3]			
	5	SCI-FP4-NGC4449_Cluster_7_v2 (COS.sp.2025762)	(7) NGC4449-SC7	COS/FUV, TIME-TAG, PSA	G130M 1291 A	BUFFER-TIME=40 33; SEGMENT=BOTH; FP-POS=4			1450 Secs (2561 Secs) [==>2561.0 Secs]	[4]			

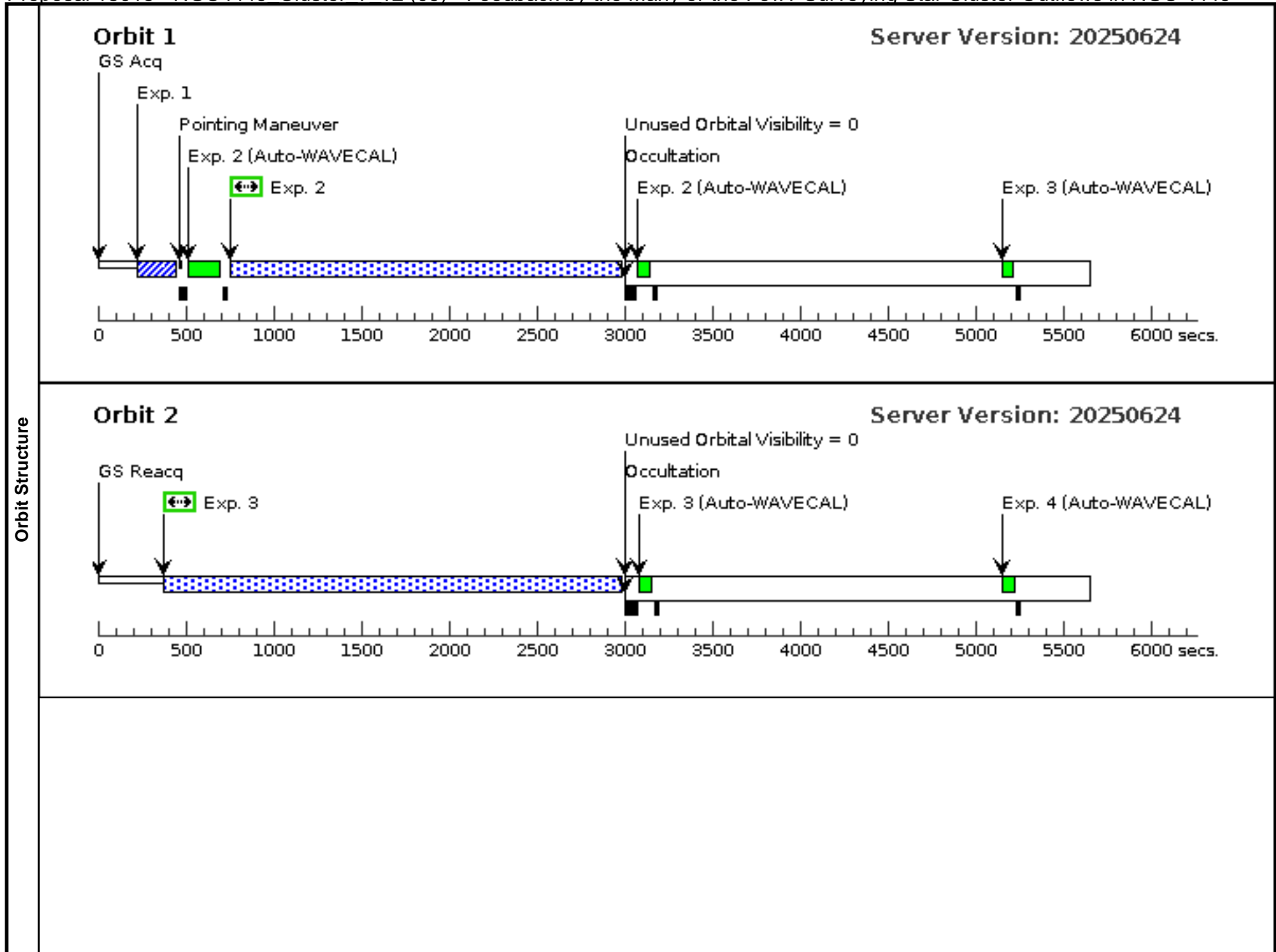

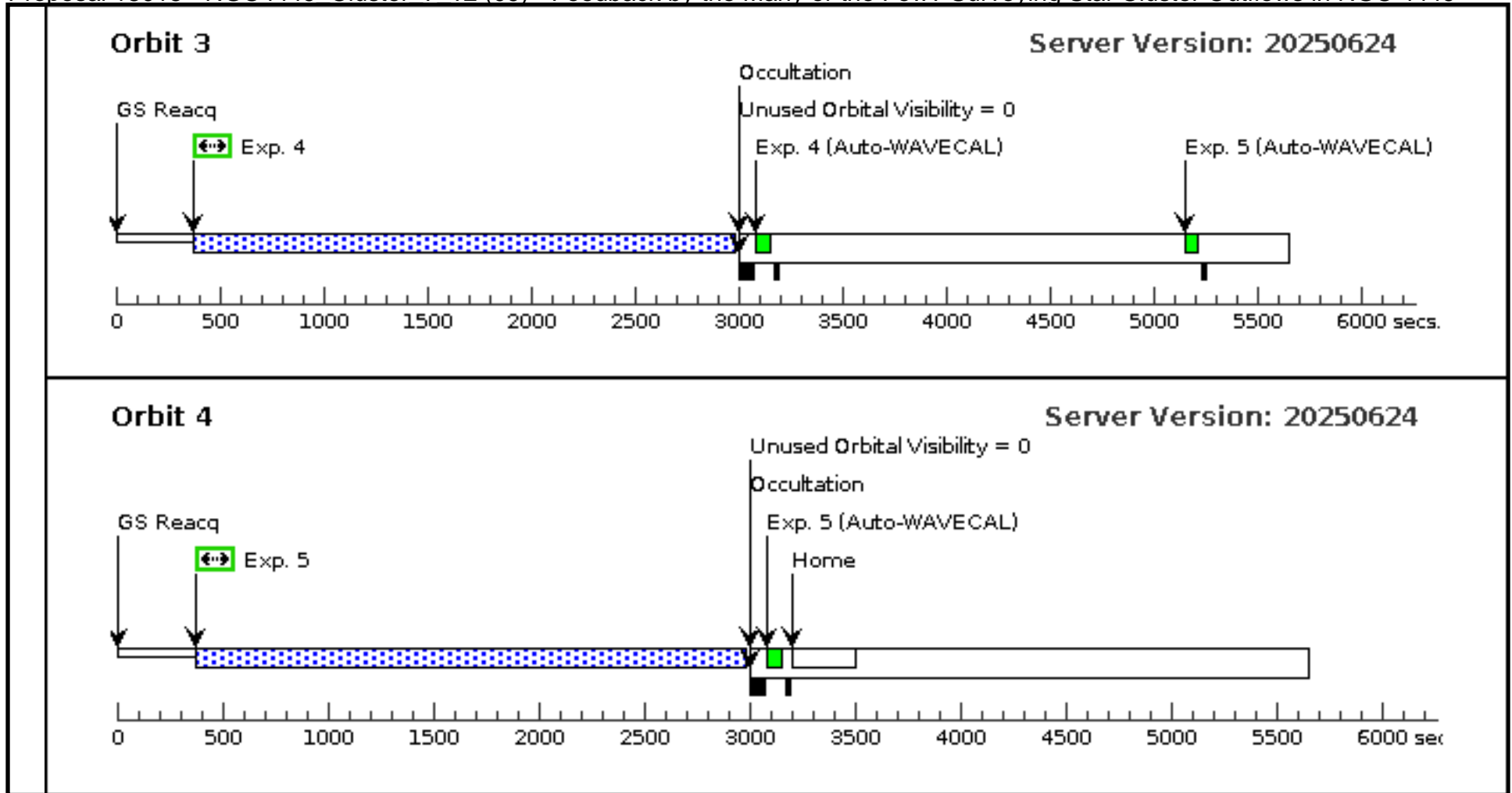

Proposal 18015 - NGC4449-Cluster 8 (10) - Feedback by the Many or the Few? Surveying Star Cluster Outflows in NGC 4449

Thu Aug 14 21:00:54 GMT 2025

Visit	Proposal 18015, NGC4449-Cluster_8 (10) Diagnostic Status: Warning Scientific Instruments: COS/FUV, COS/NUV Special Requirements: (none)									
	(NGC4449-Cluster_8 (10)) Warning (Orbit Planner): COS EXPOSURE TIME ROUNDED DOWN TO NEAREST 0.1 SECONDS									
Fixed Targets	#	Name	Target Coordinates	Targ. Coord. Corrections	Fluxes	Miscellaneous				
	(8)	NGC4449-SC8	RA: 12 28 9.2800 (187.0386667d) Dec: +44 05 8.17 (44.08560d) Equinox: J2000		V=18.7	Reference Frame: ICRS				
Comments: Category=EXT-CLUSTER Description=[STAR FORMING REGION] Extended=NO										
Exposures	#	Label (ETC Run)	Target	Config,Mode,Aperture	Spectral Els.	Opt. Params.	Special Reqs.	Groups	Exp. Time (Total)/[Actual Dur.]	Orbit
	1	ACQ-NGC4449_Cluster_8 (COS.ta.2025782)	(8) NGC4449-SC8	COS/NUV, ACQ/IMAGE, PSA	MIRRORB				5.8 Secs (5.8 Secs) [==>]	[1]
	2	SCI-FP3-N GC4449_C1 uster_8 (COS.sp.2025763)	(8) NGC4449-SC8	COS/FUV, TIME-TAG, PSA	G130M 1291 A	BUFFER-TIME=15 10; SEGMENT=BOTH; FP-POS=3			950 Secs (893 Secs) [==>893.0 Secs]	[1]
	3	SCI-FP4-N GC4449_C1 uster_8 (COS.sp.2025763)	(8) NGC4449-SC8	COS/FUV, TIME-TAG, PSA	G130M 1291 A	BUFFER-TIME=15 10; SEGMENT=BOTH; FP-POS=4			951 Secs (894 Secs) [==>894.0 Secs]	[1]

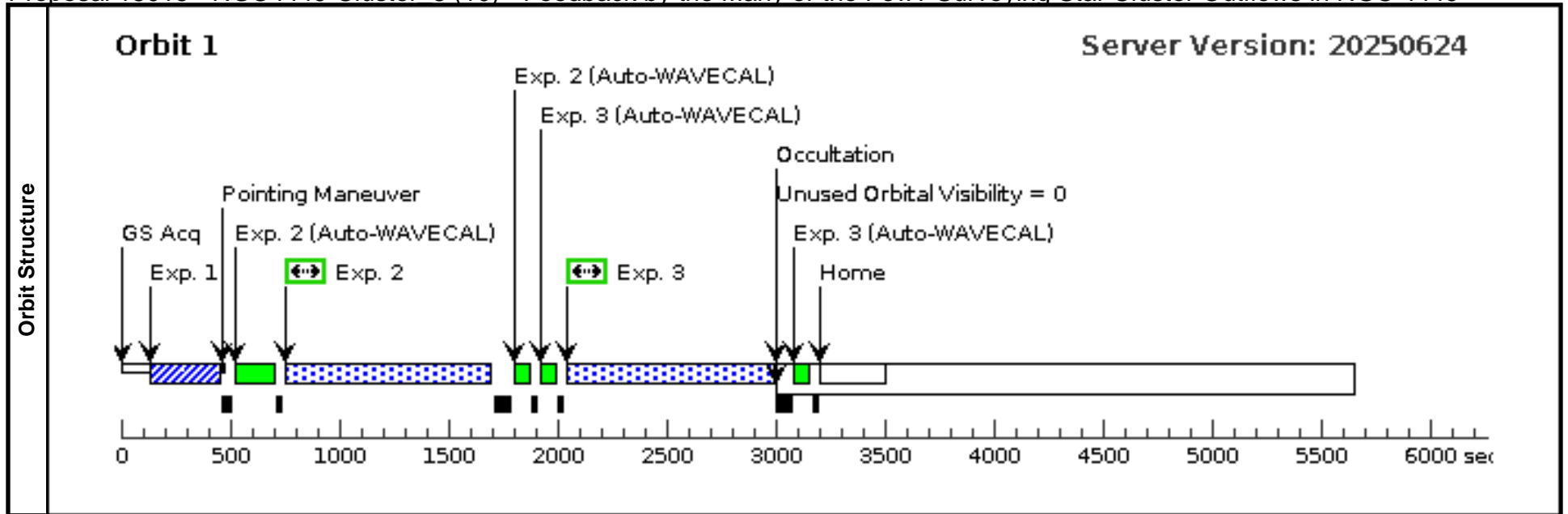

Proposal 18015 - NGC4449-Cluster 9 (11) - Feedback by the Many or the Few? Surveying Star Cluster Outflows in NGC 4449

Thu Aug 14 21:00:54 GMT 2025

Visit	Proposal 18015, NGC4449-Cluster_9 (11)				
	Diagnostic Status: No Diagnostics				
	Scientific Instruments: COS/FUV, COS/NUV				
	Special Requirements: (none)				

Fixed Targets	#	Name	Target Coordinates	Targ. Coord. Corrections	Fluxes	Miscellaneous
	(9)	NGC4449-SC9	RA: 12 28 9.8600 (187.0410833d) Dec: +44 05 9.50 (44.08597d) Equinox: J2000		V=19.0	Reference Frame: ICRS
	<i>Comments:</i>					
	Category=EXT-CLUSTER Description=[STAR FORMING REGION] Extended=NO					

Exposures	#	Label (ETC Run)	Target	Config,Mode,Aperture	Spectral Els.	Opt. Params.	Special Reqs.	Groups	Exp. Time (Total)/[Actual Dur.]	Orbit
	1	ACQ-NGC4449_Cluster_9 (COS.ta.2025784)	(9) NGC4449-SC9	COS/NUV, ACQ/IMAGE, PSA	MIRRORB				8.4 Secs (8.4 Secs) [==>]	[1]
	2	SCI-FP3-NGC4449_Cluster_9 (COS.sp.2025764)	(9) NGC4449-SC9	COS/FUV, TIME-TAG, PSA	G130M 1291 A	BUFFER-TIME=19 17;	SEGMENT=BOTH; FP-POS=3		950 Secs (893 Secs) [==>893.0 Secs]	[1]
	3	SCI-FP4-NGC4449_Cluster_9 (COS.sp.2025764)	(9) NGC4449-SC9	COS/FUV, TIME-TAG, PSA	G130M 1291 A	BUFFER-TIME=19 17;	SEGMENT=BOTH; FP-POS=4		951 Secs (894 Secs) [==>894.0 Secs]	[1]

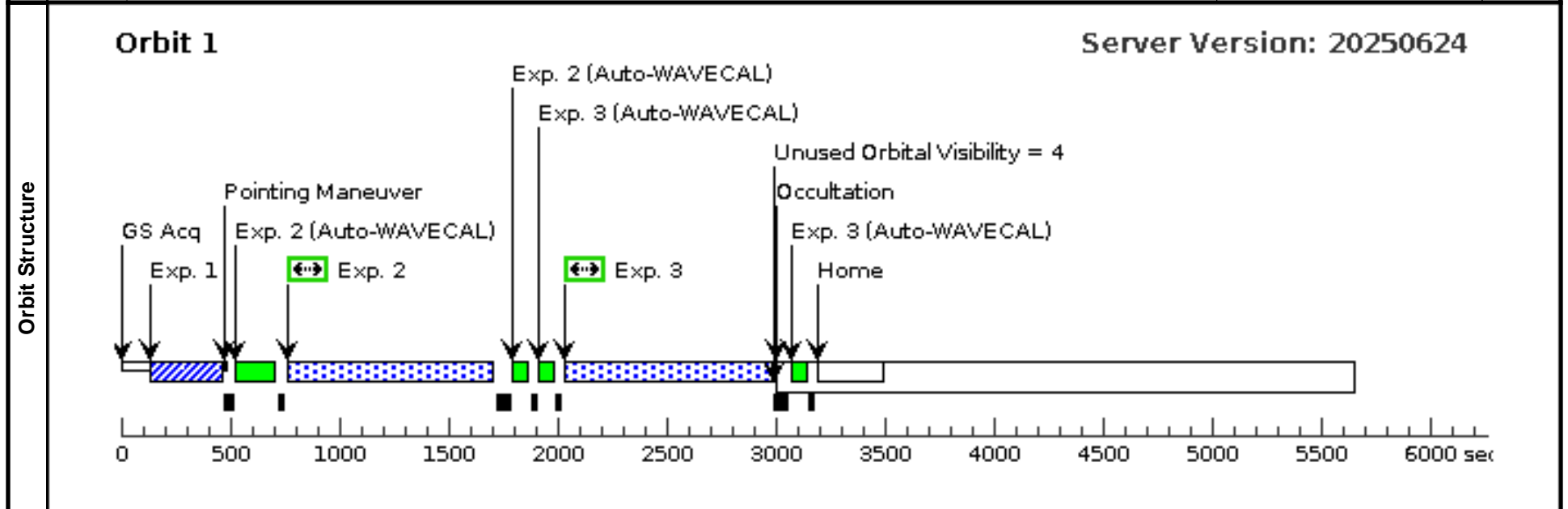

Proposal 18015 - NGC4449-Cluster 10 (12) - Feedback by the Many or the Few? Surveying Star Cluster Outflows in NGC 4449

Thu Aug 14 21:00:54 GMT 2025

Visit	Proposal 18015, NGC4449-Cluster_10 (12) Diagnostic Status: Warning Scientific Instruments: COS/FUV, COS/NUV Special Requirements: (none)									
	(NGC4449-Cluster_10 (12)) Warning (Orbit Planner): COS EXPOSURE TIME ROUNDED DOWN TO NEAREST 0.1 SECONDS									
Fixed Targets	#	Name	Target Coordinates	Targ. Coord. Corrections	Fluxes	Miscellaneous				
	(10)	NGC4449-SC10	RA: 12 28 9.6800 (187.0403333d) Dec: +44 05 10.74 (44.08632d) Equinox: J2000		V=19.1	Reference Frame: ICRS				
Comments: Category=EXT-CLUSTER Description=[STAR FORMING REGION] Extended=NO										
Exposures	#	Label (ETC Run)	Target	Config,Mode,Aperture	Spectral Els.	Opt. Params.	Special Reqs.	Groups	Exp. Time (Total)/[Actual Dur.]	Orbit
	1	ACQ-NGC4449_Cluster_10 (COS.ta.2025787)	(10) NGC4449-SC10	COS/NUV, ACQ/IMAGE, PSA	MIRRORB				4.8 Secs (4.8 Secs) [==>]	[1]
	2	SCI-FP3-N GC4449_C1 uster_10 (COS.sp.2025766)	(10) NGC4449-SC10	COS/FUV, TIME-TAG, PSA	G130M 1291 A	BUFFER-TIME=13 25; SEGMENT=BOTH; FP-POS=3			951 Secs (890 Secs) [==>890.0 Secs]	[1]
	3	SCI-FP4-N GC4449_C1 uster_10 (COS.sp.2025766)	(10) NGC4449-SC10	COS/FUV, TIME-TAG, PSA	G130M 1291 A	BUFFER-TIME=13 25; SEGMENT=BOTH; FP-POS=4			951 Secs (890 Secs) [==>890.0 Secs]	[1]

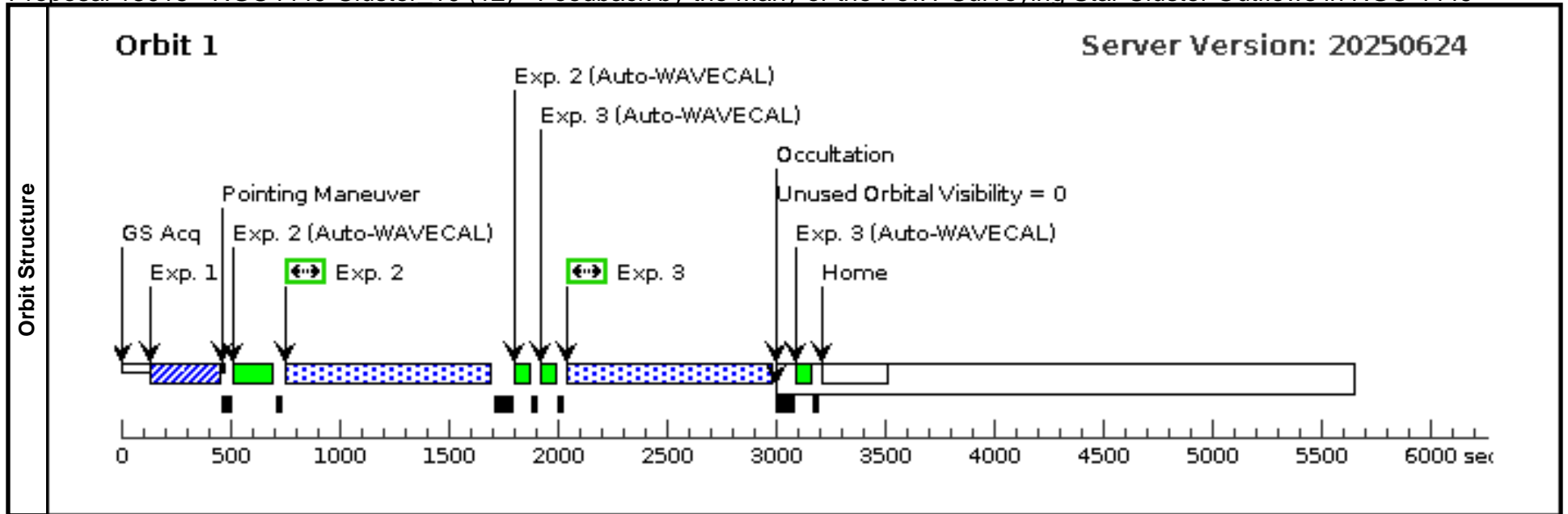

Proposal 18015 - NGC4449-Cluster 11 (13) - Feedback by the Many or the Few? Surveying Star Cluster Outflows in NGC 4449

Thu Aug 14 21:00:54 GMT 2025

Visit	Proposal 18015, NGC4449-Cluster_11 (13) Diagnostic Status: Warning Scientific Instruments: COS/FUV, COS/NUV Special Requirements: (none)									
	(NGC4449-Cluster_11 (13)) Warning (Orbit Planner): COS EXPOSURE TIME ROUNDED DOWN TO NEAREST 0.1 SECONDS									
Fixed Targets	#	Name	Target Coordinates	Targ. Coord. Corrections	Fluxes	Miscellaneous				
	(11)	NGC4449-SC11	RA: 12 28 9.6100 (187.0400417d) Dec: +44 05 15.94 (44.08776d) Equinox: J2000		V=18.3	Reference Frame: ICRS				
Comments: Category=EXT-CLUSTER Description=[STAR FORMING REGION] Extended=NO										
Exposures	#	Label (ETC Run)	Target	Config,Mode,Aperture	Spectral Els.	Opt. Params.	Special Reqs.	Groups	Exp. Time (Total)/[Actual Dur.]	Orbit
	1	ACQ-NGC4449_Cluster_11 (COS.ta.2025789)	(11) NGC4449-SC11	COS/NUV, ACQ/IMAGE, PSA	MIRRORB				6.3 Secs (6.3 Secs) [==>]	[1]
	2	SCI-FP3-N GC4449_C1 uster_11 (COS.sp.2025768)	(11) NGC4449-SC11	COS/FUV, TIME-TAG, PSA	G130M 1291 A	BUFFER-TIME=16 07; SEGMENT=BOTH; FP-POS=3			907 Secs (897 Secs) [==>897.0 Secs]	[1]
	3	SCI-FP4-N GC4449_C1 uster_11 (COS.sp.2025768)	(11) NGC4449-SC11	COS/FUV, TIME-TAG, PSA	G130M 1291 A	BUFFER-TIME=16 07; SEGMENT=BOTH; FP-POS=4			898 Secs (888 Secs) [==>888.0 Secs]	[1]

